



## STGD3NB60H

N-CHANNEL 3A - 600V - DPAK

PowerMESH™ IGBT

TYPE	V <sub>CES</sub>	V <sub>CE(sat)</sub>	I <sub>C</sub>
STD3NB60H	600 V	< 2.8 V	3 A

- HIGH INPUT IMPEDANCE
- LOW ON-VOLTAGE DROP (V<sub>cesat</sub>)
- OFF LOSSES INCLUDE TAIL CURRENT
- LOW GATE CHARGE
- HIGH CURRENT CAPABILITY
- VERY HIGH FREQUENCY OPERATION
- CO-PACKAGED WITH TURBOSWITCHT
- TYPICAL SHORT CIRCUIT WITHSTAND TIME  
5MICROS S-family, 4 micro H family
- ANTIPARALLEL DIODE

### DESCRIPTION

Using the latest high voltage technology based on a patented strip layout, STMicroelectronics has designed an advanced family of IGBTs, the PowerMESH™ IGBTs, with outstanding performances.

The suffix "H" identifies a family optimized for high frequency applications (up to 50kHz) in order to achieve very high switching performances (reduced t<sub>fall</sub>) maintaining a low voltage drop.

### APPLICATIONS

- HIGH FREQUENCY MOTOR CONTROLS
- SMPS and PFC IN BOTH HARD SWITCH AND RESONANT TOPOLOGIES

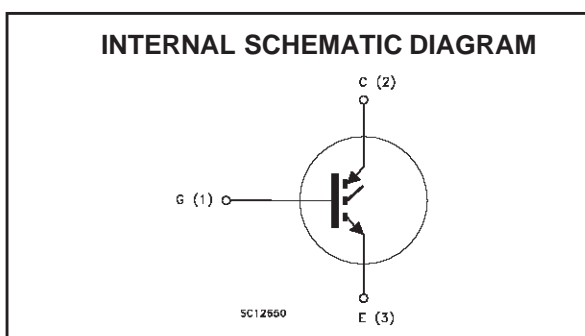
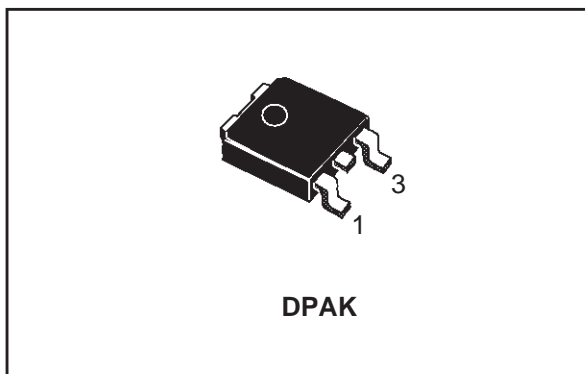

### ABSOLUTE MAXIMUM RATINGS

Symbol	Parameter	Value	Unit
V <sub>CES</sub>	Collector-Emitter Voltage (V <sub>GS</sub> = 0)	600	V
V <sub>ECR</sub>	Emitter-Collector Voltage	20	V
V <sub>GE</sub>	Gate-Emitter Voltage	± 20	V
I <sub>C</sub>	Collector Current (continuous) at T <sub>C</sub> = 25°C	6	A
I <sub>C</sub>	Collector Current (continuous) at T <sub>C</sub> = 100°C	3	A
I <sub>CM</sub> (■)	Collector Current (pulsed)	24	A
P <sub>TOT</sub>	Total Dissipation at T <sub>C</sub> = 25°C	35	W
	Derating Factor	0.28	W/°C
T <sub>stg</sub>	Storage Temperature	-65 to 150	°C
T <sub>j</sub>	Max. Operating Junction Temperature	150	°C

## STGD3NB60H

### THERMAL DATA

Rthj-case	Thermal Resistance Junction-case Max	3.57	°C/W
Rthj-amb	Thermal Resistance Junction-ambient Max	100	°C/W
Rthc-sink	Thermal Resistance Case-sink Typ	1.5	°C/W

### ELECTRICAL CHARACTERISTICS (TCASE = 25 °C UNLESS OTHERWISE SPECIFIED)

OFF

Symbol	Parameter	Test Conditions	Min.	Typ.	Max.	Unit
$V_{BR(CEs)}$	Collectro-Emitter Breakdown Voltage	$I_C = 250 \mu A, V_{GE} = 0$	600			V
$I_{CES}$	Collector cut-off ( $V_{GE} = 0$ )	$V_{CE} = \text{Max Rating}, T_C = 25 \text{ }^\circ\text{C}$ $V_{CE} = \text{Max Rating}, T_C = 125 \text{ }^\circ\text{C}$			10 100	$\mu A$ $\mu A$
$I_{GES}$	Gate-Emitter Leakage Current ( $V_{CE} = 0$ )	$V_{GE} = \pm 20V, V_{CE} = 0$			$\pm 100$	nA

ON (1)

Symbol	Parameter	Test Conditions	Min.	Typ.	Max.	Unit
$V_{GE(th)}$	Gate Threshold Voltage	$V_{CE} = V_{GE}, I_C = 250\mu A$	3		5	V
$V_{CE(sat)}$	Collector-Emitter Saturation Voltage	$V_{GE} = 15V, I_C = 3 A$ $V_{GE} = 15V, I_C = 3 A, T_J = 125^\circ C$		2.4 1.9	2.8	V V

DYNAMIC

Symbol	Parameter	Test Conditions	Min.	Typ.	Max.	Unit
$g_{fs}$	Forward Transconductance	$V_{CE} = 25 V, I_C = 3 A$	1.3	2.4		S
$C_{ies}$	Input Capacitance	$V_{CE} = 25V, f = 1 \text{ MHz}, V_{GE} = 0$		235		pF
$C_{oes}$	Output Capacitance			33		pF
$C_{res}$	Reverse Transfer Capacitance			6.6		pF
$Q_g$	Total Gate Charge	$V_{CE} = 480V, I_C = 3 A,$ $V_{GE} = 15V$		21	27	nC
$Q_{ge}$	Gate-Emitter Charge			6		nC
$Q_{gc}$	Gate-Collector Charge			7.6		nC
$I_{CL}$	Latching Current	$V_{clamp} = 480 V, T_J = 125^\circ C$ $R_G = 10 \Omega$	12			A

SWITCHING ON

Symbol	Parameter	Test Conditions	Min.	Typ.	Max.	Unit
$t_{d(on)}$	Turn-on Delay Time	$V_{CC} = 480 V, I_C = 3 A$ $R_G = 10\Omega, V_{GE} = 15 V$		16		ns
$t_r$	Rise Time			30		ns
$(di/dt)_{on}$	Turn-on Current Slope	$V_{CC} = 480 V, I_C = 3 A R_G = 10\Omega$ $V_{GE} = 15 V, T_J = 125^\circ C$		400		A/ $\mu s$
$E_{on}$	Turn-on Switching Losses			37		$\mu J$

**ELECTRICAL CHARACTERISTICS (CONTINUED)**

**SWITCHING OFF**

Symbol	Parameter	Test Conditions	Min.	Typ.	Max.	Unit
$t_c$	Cross-over Time	$V_{CC} = 480\text{ V}, I_C = 3\text{ A},$ $R_{GE} = 10\ \Omega, V_{GE} = 15\text{ V}$		90		ns
$t_r(V_{off})$	Off Voltage Rise Time			36		ns
$t_{d(off)}$	Delay Time			53		ns
$t_f$	Fall Time			70		ns
$E_{off(**)}$	Turn-off Switching Loss			33		$\mu\text{J}$
$E_{ts}$	Total Switching Loss			65		$\mu\text{J}$
$t_c$	Cross-over Time	$V_{CC} = 480\text{ V}, I_C = 3\text{ A},$ $R_{GE} = 10\ \Omega, V_{GE} = 15\text{ V}$ $T_j = 125\text{ }^\circ\text{C}$		180		ns
$t_r(V_{off})$	Off Voltage Rise Time			82		ns
$t_{d(off)}$	Delay Time			58		ns
$t_f$	Fall Time			110		ns
$E_{off(**)}$	Turn-off Switching Loss			88		$\mu\text{J}$
$E_{ts}$	Total Switching Loss			125		$\mu\text{J}$

Note: 1. Pulsed: Pulse duration = 300  $\mu\text{s}$ , duty cycle 1.5 %.  
 2. Pulse width limited by max. junction temperature.  
 (\*\*)Losses include Also the Tail (Jedec Standardization)

**Thermal Impedance**

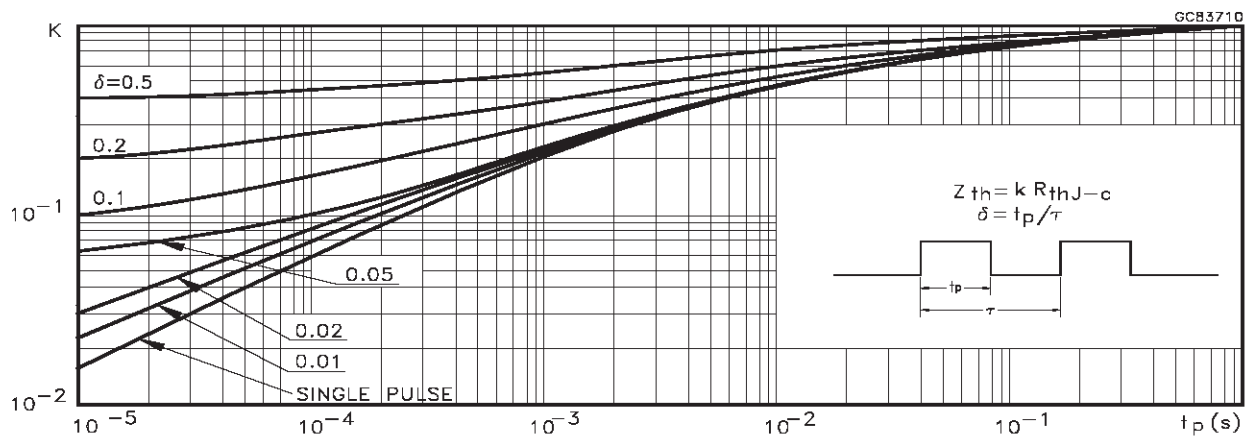

Output Characteristics

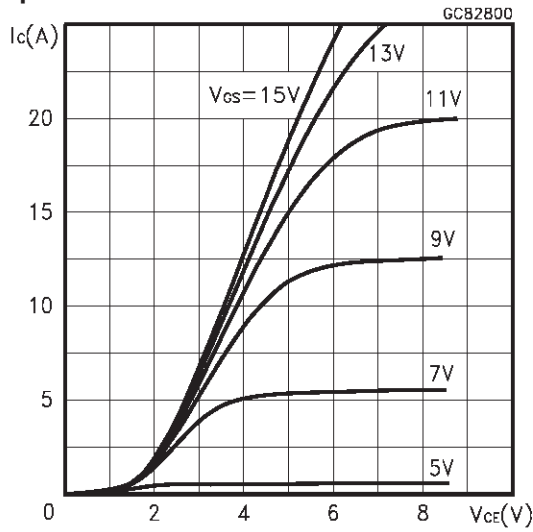

Transfer Characteristics

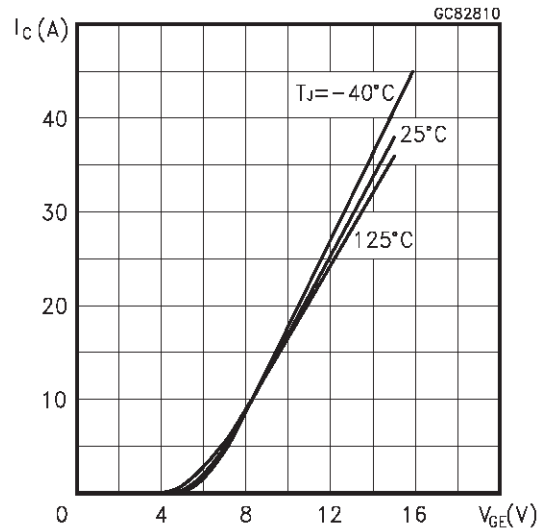

Transconductance

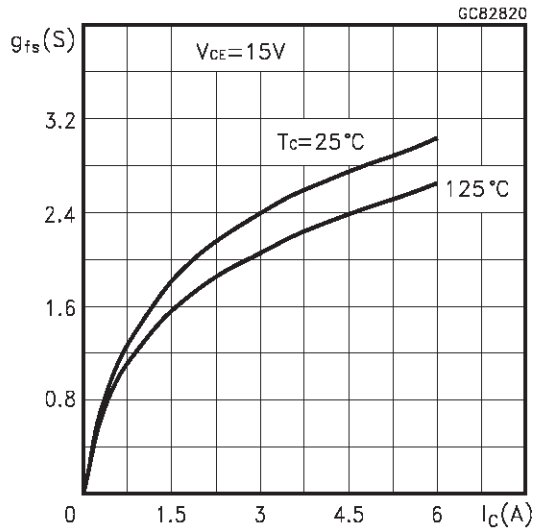

Collector-Emitter On Voltage vs Temperature

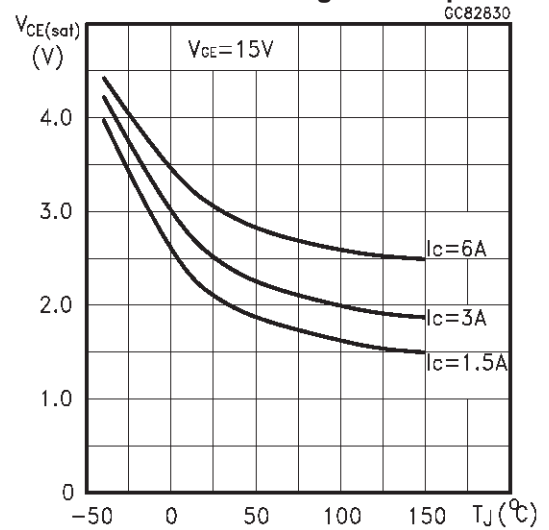

Collector-Emitter On Voltage vs Collector Current

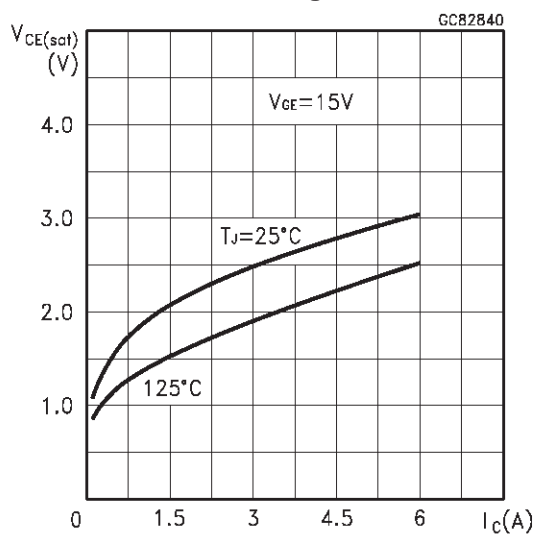

Gate Threshold vs Temperature

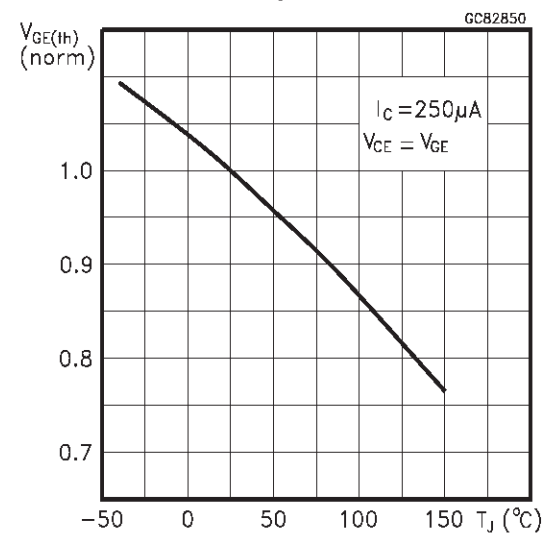

Normalized Breakdown Voltage vs Temperature

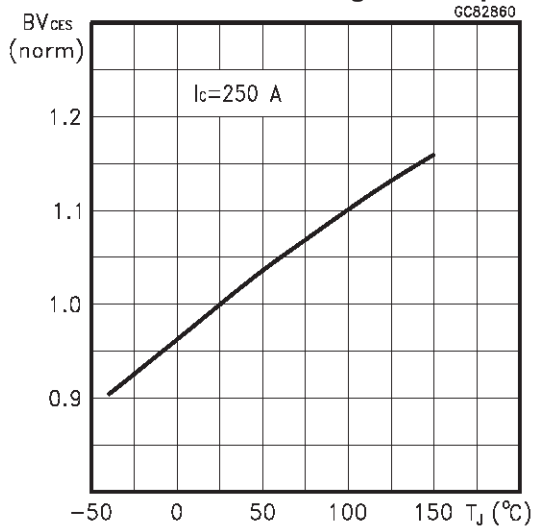

Capacitance Variations

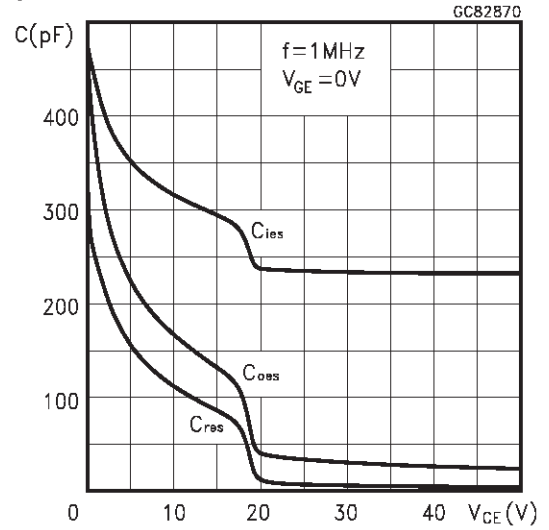

Gate Charge vs Gate-Emitter Voltage

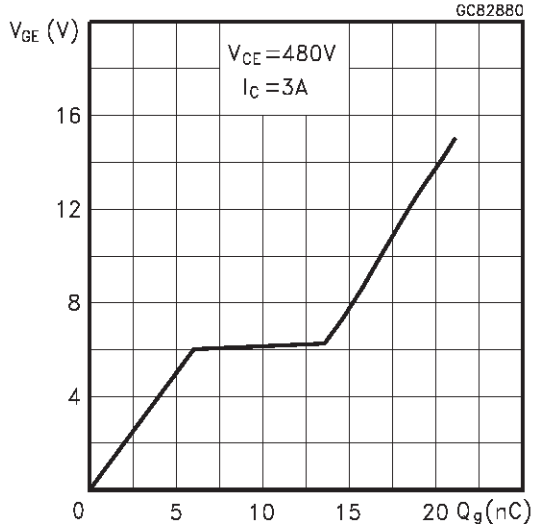

Total Switching Losses vs Gate Resistance

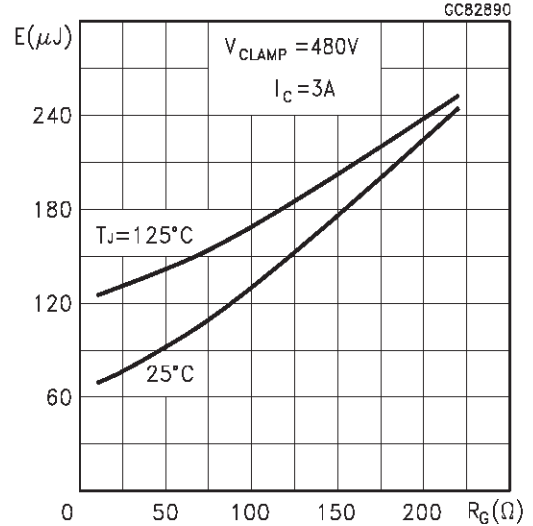

Total Switching Losses vs Temperature

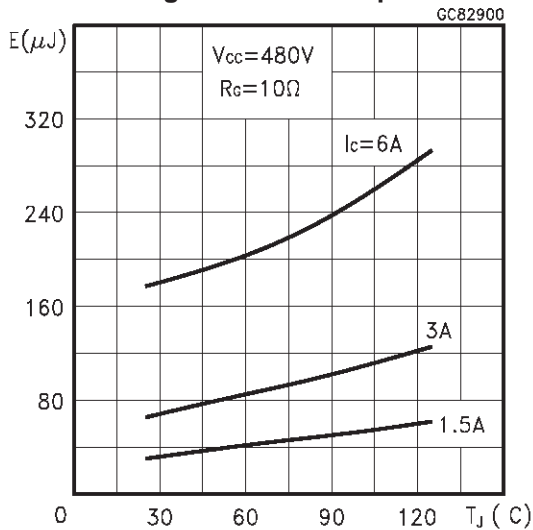

Total Switching Losses vs Collector Current

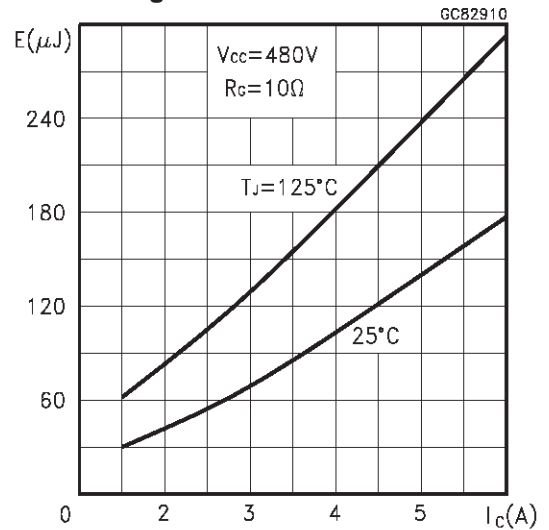

Switching Off Safe Operating Area

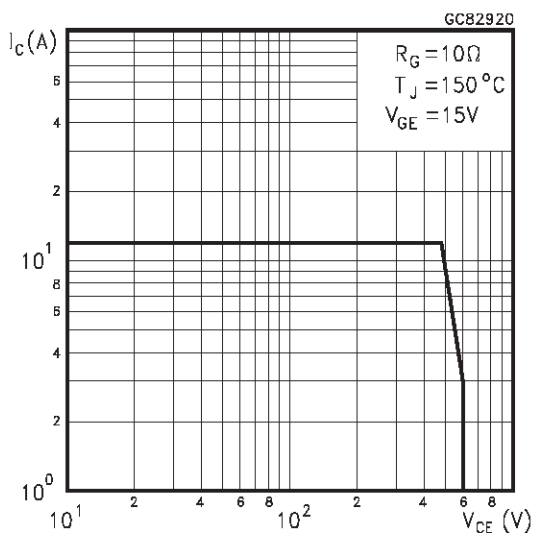

Fig. 1: Gate Charge test Circuit

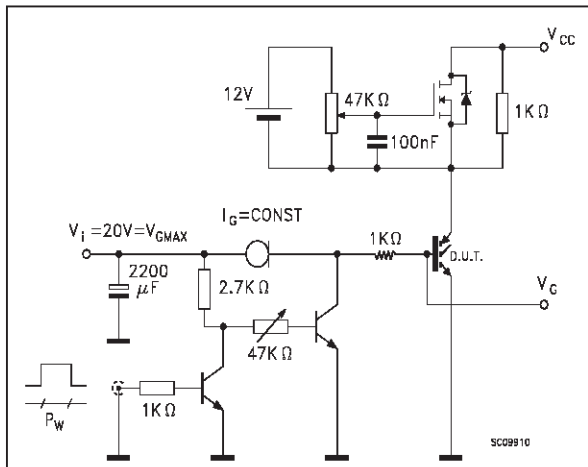
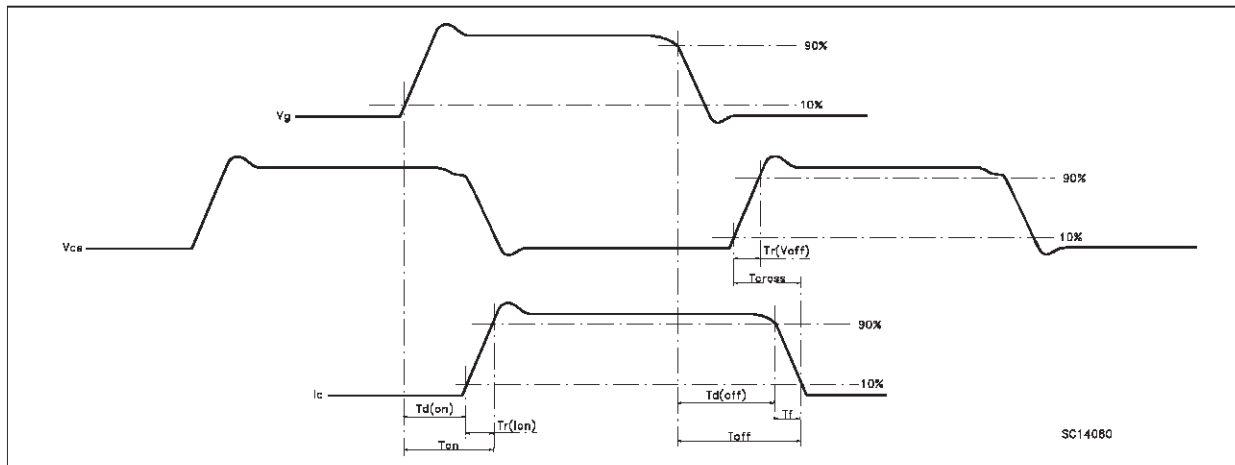
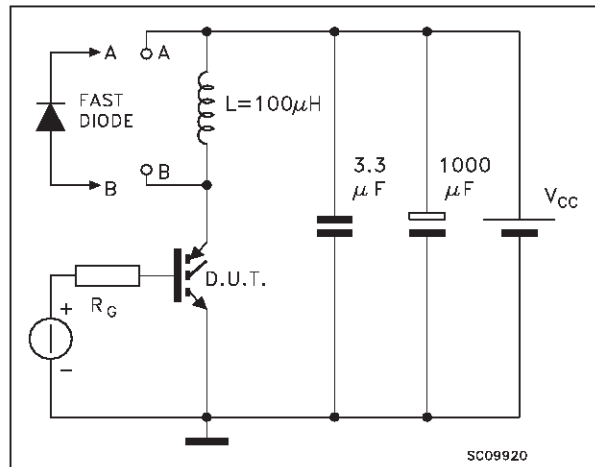
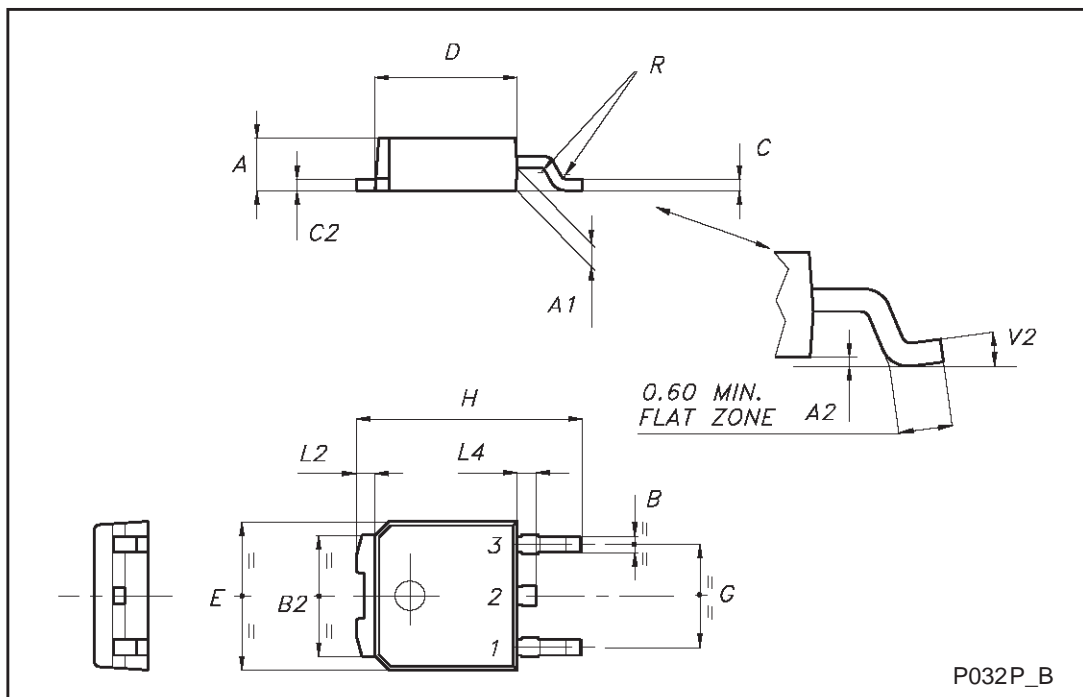

Fig. 2: Test Circuit For Inductive Load Switching



TO-252 (DPAK) MECHANICAL DATA

DIM.	mm			inch		
	MIN.	TYP.	MAX.	MIN.	TYP.	MAX.
A	2.20		2.40	0.087		0.094
A1	0.90		1.10	0.035		0.043
A2	0.03		0.23	0.001		0.009
B	0.64		0.90	0.025		0.035
B2	5.20		5.40	0.204		0.213
C	0.45		0.60	0.018		0.024
C2	0.48		0.60	0.019		0.024
D	6.00		6.20	0.236		0.244
E	6.40		6.60	0.252		0.260
G	4.40		4.60	0.173		0.181
H	9.35		10.10	0.368		0.398
L2		0.8			0.031	
L4	0.60		1.00	0.024		0.039
V2	0°		8°	0°		0°



Information furnished is believed to be accurate and reliable. However, STMicroelectronics assumes no responsibility for the consequences of use of such information nor for any infringement of patents or other rights of third parties which may result from its use. No license is granted by implication or otherwise under any patent or patent rights of STMicroelectronics. Specification mentioned in this publication are subject to change without notice. This publication supersedes and replaces all information previously supplied. STMicroelectronics products are not authorized for use as critical components in life support devices or systems without express written approval of STMicroelectronics.

The ST logo is a trademark of STMicroelectronics

© 2000 STMicroelectronics – Printed in Italy – All Rights Reserved

STMicroelectronics GROUP OF COMPANIES

Australia - Brazil - China - Finland - France - Germany - Hong Kong - India - Italy - Japan - Malaysia - Malta - Morocco -  
Singapore - Spain - Sweden - Switzerland - United Kingdom - U.S.A.

<http://www.st.com>