



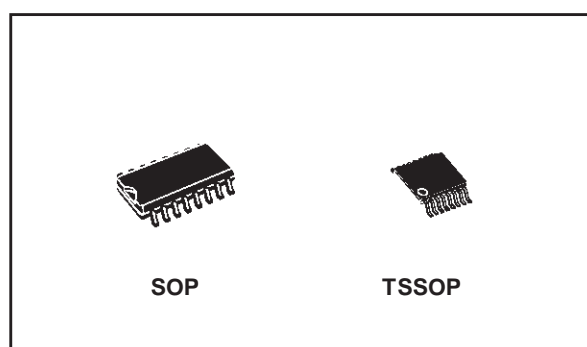
# STLVDS104

## 4-PORT LVDS AND 4-PORT TTL-TO LVDS REPEATERS

- RECEIVER AND DRIVERS MEET OR EXCEED THE REQUIREMENTS OF ANSI EIA/TIA-644 STANDARD, RECEIVERS DIFFERENTIAL INPUT LEVELS,  $\pm 100\text{mV}$
- DESIGNED FOR SIGNALING RATES UP TO 630Mbps
- OPERATES FROM A SINGLE 3.3V SUPPLY
- LOW VOLTAGE DIFFERENTIAL SIGNALING WITH TYPICAL OUTPUT VOLTAGE OF 350mV AND A 100 $\Omega$  LOAD
- PROPAGATION DELAY TIME: 3.1ns (TYP)
- ELECTRICALLY COMPATIBLE WITH LVDS, PECL, LVPECL, LVTTTL, LVCOMOS, GTL, BTL, CTT, SSTL, OR HSTL OUTPUTS WITH EXTERNAL NETWORK
- ESD PROTECTION (HBM): 7KV
- BUS TERMINA ESD EXCEEDS 7KV
- SO AND TSSOP PACKAGING

### DESCRIPTION

The STLVDS104 is a differential line receiver and a LVTTTL input connected to four differential line drives that implement the electrical characteristics of low voltage differential signaling, for point to point baseband data transmission over controlled impedance media approximately 100 $\Omega$ . The transission media may be printed-circuit board traces, backplanes, or cable.



LVDS, as specified in EIA/TIA-644 is a data signaling technique that offers low-power, low noisecoupling, and switching speed to transmit data at speed up to 630Mbps at relatively long distances.

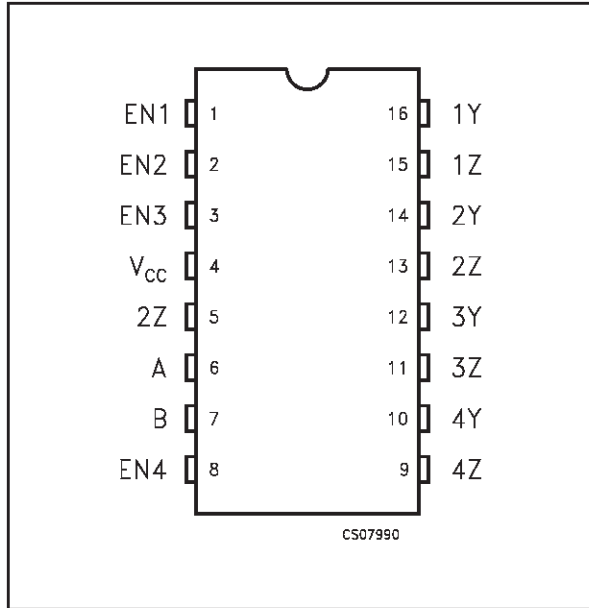
Having the drivers integrated into the same substrate, along with the low pulse skew of balanced signaling, allow extremely precise timing alignment of the signals repeated from the input. The device allow extremely precise timing alignment of the signal repeated from the input. This is particularly advantageous in distribution or expansion of signals such as clock or serial data stream.

### ORDERING CODES

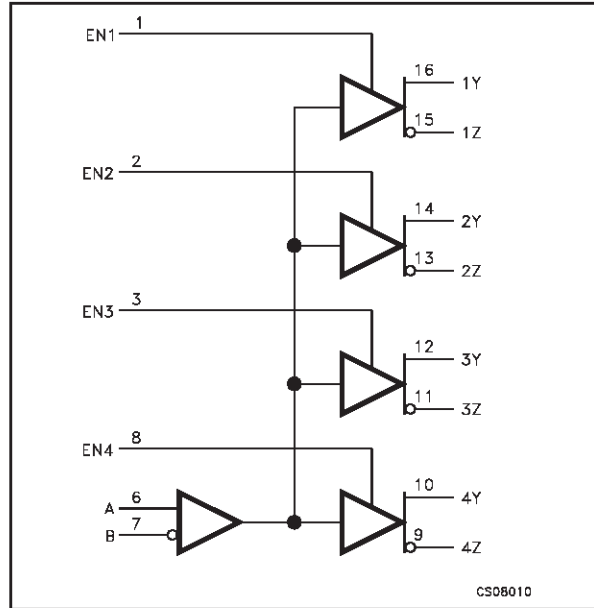
Type	Temperature Range	Package	Comments
STLVDS104BD	-40 to 85 °C	SO-16 (Tube)	50parts per tube / 20tube per box
STLVDS104BDR	-40 to 85 °C	SO-16 (Tape & Reel)	2500 parts per reel
STLVDS104BTR	-40 to 85 °C	TSSOP16 (Tape & Reel)	2500 parts per reel

# STLVDS104

## PIN CONFIGURATION



## FUNCTIONAL DIAGRAM



## PIN DESCRIPTION

PIN N°	SYMBOL	NAME AND FUNCTION
1, 2, 3, 8	EN1 to EN4	Enable Driver Inputs
6, 7	A, B	Receiver Input
9, 11, 13, 15	1Z to 4Z	Driver Inputs
10, 12, 14, 16	1X to 4X	Driver Inputs
5	GND	Ground
4	V <sub>CC</sub>	Supply Voltage

## FUNCTIONAL TABLE

INPUT	ENABLES	OUTPUTS	
		#Y	#Z
$V_{ID} = V_A - V_B$	#EN	#Y	#Z
X	X	Z	Z
X	L	Z	Z
$V_{ID} \geq 100\text{mV}$	H	H	L
$-100\text{mV} < V_{ID} < 100\text{mV}$	H	?	?
$V_{ID} \leq -100\text{mV}$	H	L	H

L=Low level, H=High Level, ?=Indeterminate, Z= High Impedance

## ABSOLUTE MAXIMUM RATINGS

Symbol	Parameter	Value	Unit
V <sub>CC</sub>	Supply Voltage (Note 1)	-0.5 to 4	V
V <sub>R</sub>	Voltage Range	Enable Inputs	-0.5 to 6
		A, B, Y or Z	-0.5 to 4
		Y, Z, to GND	7
ESD	ESD Protection Voltage (HBM)	Y, Z, to GND	7
		All Pins	2
T <sub>stg</sub>	Storage Temperature Range	-65 to +150	°C

Absolute Maximum Ratings are those values beyond which damage to the device may occur. Functional operation under these condition is not implied.

Note 1: All voltages except differential I/O bus voltage, are with respect to the network ground terminal.

## RECOMMENDED OPERATING CONDITIONS

Symbol	Parameter	Min.	Typ.	Max.	Unit
V <sub>CC</sub>	Supply Voltage	3.0	3.3	3.6	V
V <sub>IH</sub>	HIGH Level Input Voltage	2.0			V
V <sub>IL</sub>	LOW Level Input Voltage			0.8	V
V <sub>ID</sub>	Magnitude Of Differential Input Voltage	0.1		3.6	V
V <sub>IC</sub>	Common Mode Input Voltage	V <sub>ID</sub>  /2		24· V <sub>ID</sub>  /2	V
				V <sub>CC</sub> -0.8	
T <sub>A</sub>	Operating Temperature Range	-40		85	°C

**ELECTRICAL CHARACTERISTICS** (T<sub>A</sub> = -40 to 85°C, and V<sub>CC</sub> = 3.3V ±10% over recommended operating conditions unless otherwise noted. All typical values are at T<sub>A</sub> = 25°C)

Symbol	Parameter	Test Conditions	Min.	Typ.	Max.	Unit
V <sub>ITH+</sub>	Positive-going Differential Input Voltage Threshold				100	mV
V <sub>ITH-</sub>	Negative-going Differential Input Voltage Threshold		-100			mV
V <sub>OD</sub>	Differential Output Voltage Magnitude	R <sub>L</sub> = 100Ω V <sub>ID</sub> = ±100mV	247	350	454	mV
Δ V <sub>OD</sub>	Change in Differential Output Voltage Magnitude Between Logic State		-50		50	mV
ΔV <sub>OC(SS)</sub>	Change in Steady-state Common Mode Output Voltage Between Logic State		-50		50	mV
V <sub>OC(SS)</sub>	Steady-state Common Mode Output Voltage		1.125	1.2	1.375	V
V <sub>OC(PP)</sub>	Peak to Peak Common mode Output Voltage			25	150	mV
I <sub>CC</sub>	Supply Current	Enabled, R <sub>L</sub> = 100Ω		20	30	mA
		Disabled		2.5	5	mA
I <sub>I</sub>	Input Current (A or B Inputs)	V <sub>I</sub> = 0V	-2	-11	-20	μA
		V <sub>I</sub> = 2.4V	-1	-3		μA
I <sub>I(OFF)</sub>	Power OFF Input Current	V <sub>CC</sub> = 1.5V V <sub>I</sub> = 2.4V		3	20	μA
I <sub>IH</sub>	High Level Input Current	V <sub>IH</sub> = 2V		7	20	μA
I <sub>IL</sub>	Low Level Input Current	V <sub>IL</sub> = 0.8V		3	10	μA
I <sub>OC</sub>	Short Circuit Output Current	V <sub>O(Y)</sub> or V <sub>O(Z)</sub> = 0V		± 6	± 10	mA
		V <sub>OD</sub> = 0		± 3	± 10	mA
I <sub>OZ</sub>	High Impedance Output Current	V <sub>O</sub> = 0 or 2.4V			± 1	μA
I <sub>O(OFF)</sub>	Power OFF Output Current	V <sub>CC</sub> = 1.5V V <sub>O</sub> = 2.4V			± 1	μA
C <sub>IN</sub>	Input Capacitance (A or B Inputs)	V <sub>I</sub> = 0.4 sin(4e <sup>6πt</sup> )+0.5V		3		pF
C <sub>O</sub>	Output Capacitance (Y or Z Outputs)	V <sub>I</sub> = 0.4 sin(4e <sup>6πt</sup> )+0.5V, Disabled		6		pF

**SWITCHING CHARACTERISTICS** ( $T_A = -40$  to  $85^\circ\text{C}$ , and  $V_{CC} = 3.3\text{V}$  unless otherwise noted. All typical values are at  $T_A = 25^\circ\text{C}$ )

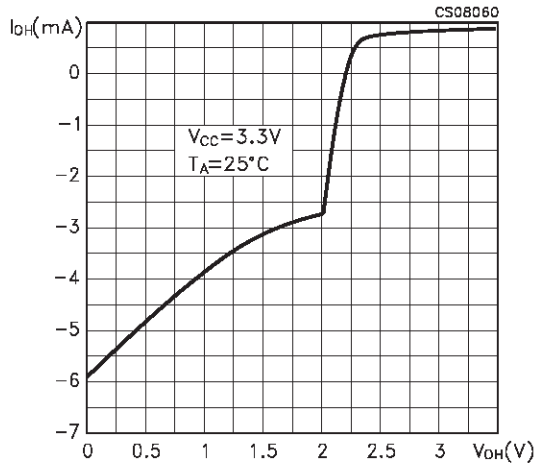
Symbol	Parameter	Test Conditions	Min.	Typ.	Max.	Unit	
$t_{PLH}$	Propagation Delay Time, Low to High Output	$R_L = 100\Omega$ $C_L = 10\text{pF}$	2.4	3.2	4.2	ns	
$t_{PHL}$	Propagation Delay Time, High to Low Output		2.2	3.1	4.2	ns	
$t_r$	Differential Output Signal Rise Time		0.3	0.6	1.2	ns	
$t_f$	Differential Output Signal Fall Time		0.3	0.7	1.2	ns	
$t_{sk(P)}$	Pulse Skew ( $ t_{THL} - t_{TLH} $ )			100	300	ps	
$t_{sk(O)}$	Channel-to-channel Output Skew (note1)			50	100	ps	
$t_{sk(pp)}$	Part to part Skew (note2)				1.5	ns	
$t_{PZH}$	Propagation Delay Time, High Impedance to High Level Output				7.2	15	ns
$t_{PZL}$	Propagation Delay Time, High Impedance to Low Level Output				8.4	15	ns
$t_{PHZ}$	Propagation Delay Time, High Level to High Impedance Output				3.6	15	ns
$t_{PLZ}$	Propagation Delay Time, Low Level to High Impedance Output			6	15	ns	

Note 1:  $t_{sk(O)}$  is the time difference between the  $t_{PLH}$  or  $t_{PHL}$  of all drivers of a single device with all their inputs connected together.

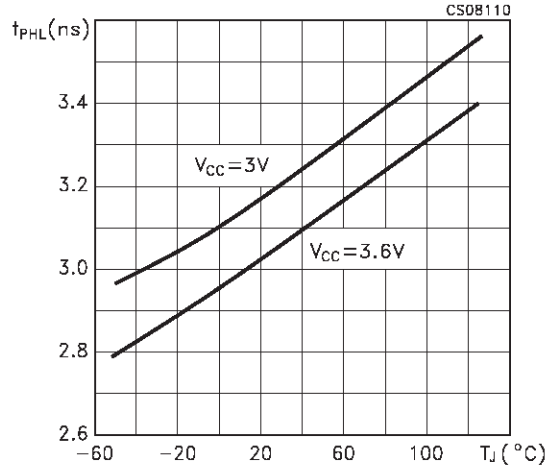
Note 2:  $t_{sk(pp)}$  is the magnitude of the difference in propagation delay times between any specified terminals of two devices when both devices operate with the same supply voltages, at the same temperature, and have identical packages and test circuit.

**TYPICAL PERFORMANCE CHARACTERISTICS** (unless otherwise specified  $T_j = 25^\circ\text{C}$ )

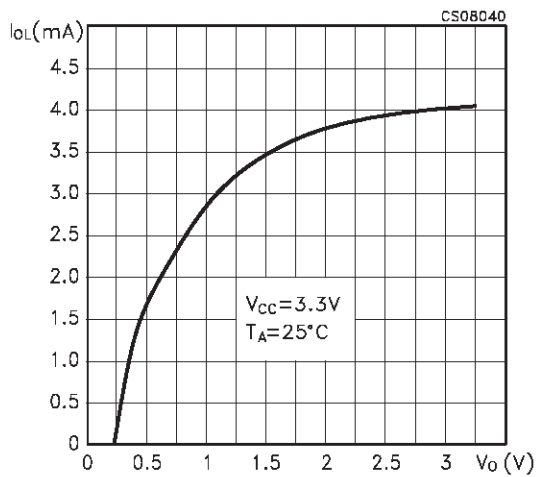
**Figure 1 :** Output Current vs Output High Voltage



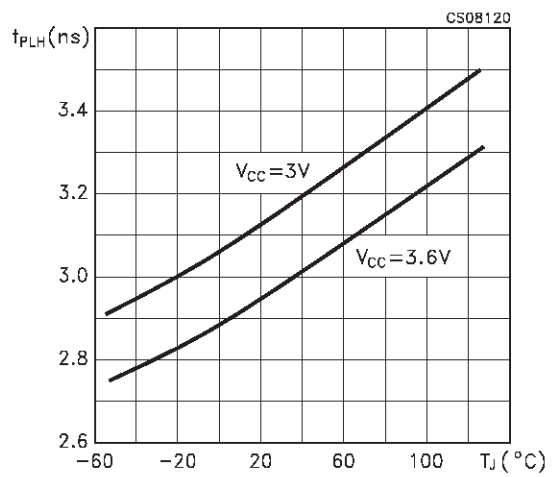
**Figure 3 :** High to Low Propagation Delay Time



**Figure 2 :** Output Current vs Output Low Voltage

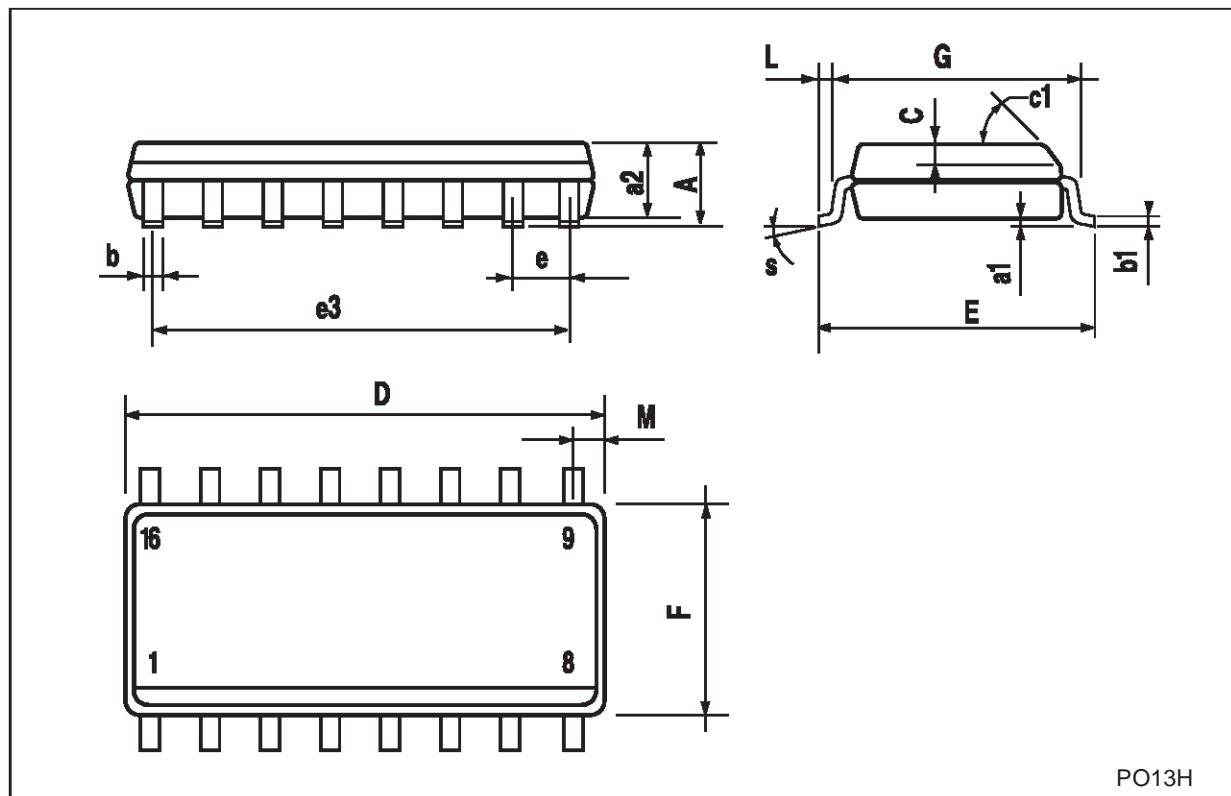


**Figure 4 :** Low to High Propagation Delay Time



## SO-16 MECHANICAL DATA

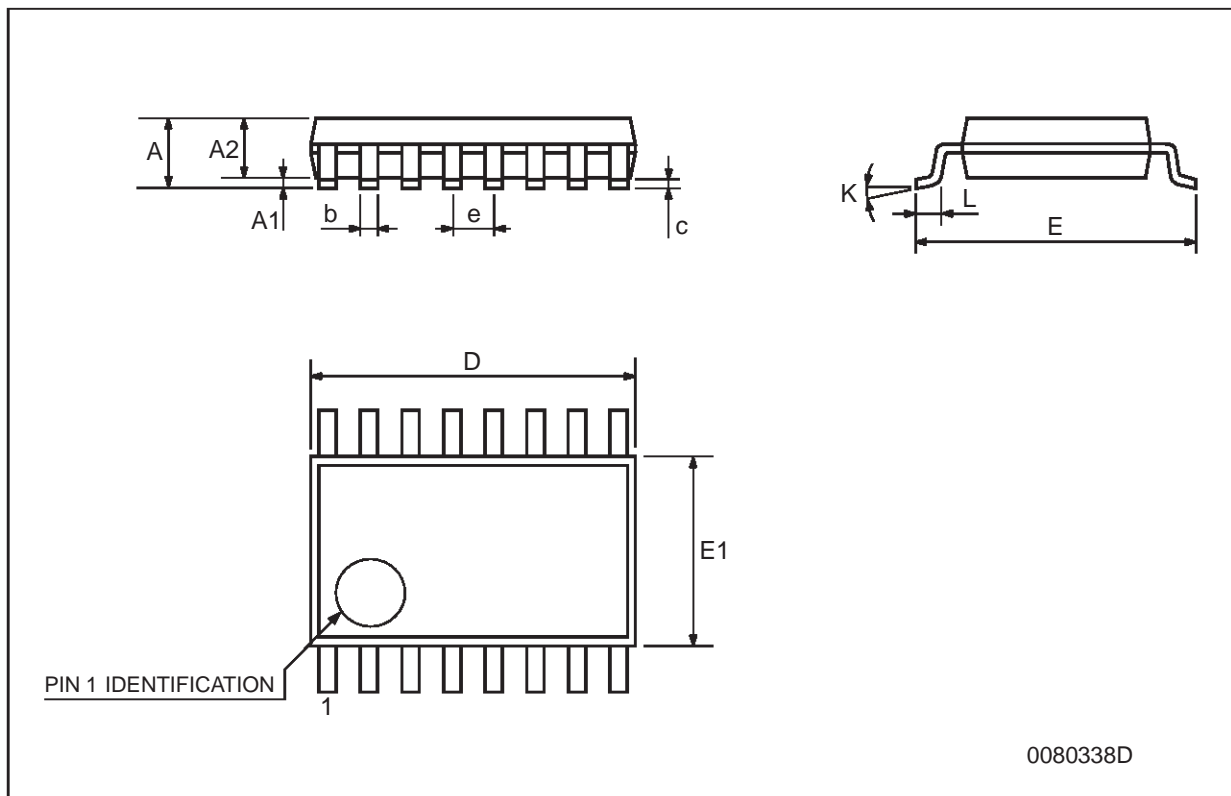
DIM.	mm.			inch		
	MIN.	TYP.	MAX.	MIN.	TYP.	MAX.
A			1.75			0.068
a1	0.1		0.2	0.003		0.007
a2			1.65			0.064
b	0.35		0.46	0.013		0.018
b1	0.19		0.25	0.007		0.010
C		0.5			0.019	
c1	45° (typ.)					
D	9.8		10	0.385		0.393
E	5.8		6.2	0.228		0.244
e		1.27			0.050	
e3		8.89			0.350	
F	3.8		4.0	0.149		0.157
G	4.6		5.3	0.181		0.208
L	0.5		1.27	0.019		0.050
M			0.62			0.024
S	8° (max.)					



PO13H

## TSSOP16 MECHANICAL DATA

DIM.	mm.			inch		
	MIN.	TYP	MAX.	MIN.	TYP.	MAX.
A			1.2			0.047
A1	0.05		0.15	0.002	0.004	0.006
A2	0.8	1	1.05	0.031	0.039	0.041
b	0.19		0.30	0.007		0.012
c	0.09		0.20	0.004		0.0089
D	4.9	5	5.1	0.193	0.197	0.201
E	6.2	6.4	6.6	0.244	0.252	0.260
E1	4.3	4.4	4.48	0.169	0.173	0.176
e		0.65 BSC			0.0256 BSC	
K	0°		8°	0°		8°
L	0.45	0.60	0.75	0.018	0.024	0.030



Information furnished is believed to be accurate and reliable. However, STMicroelectronics assumes no responsibility for the consequences of use of such information nor for any infringement of patents or other rights of third parties which may result from its use. No license is granted by implication or otherwise under any patent or patent rights of STMicroelectronics. Specifications mentioned in this publication are subject to change without notice. This publication supersedes and replaces all information previously supplied. STMicroelectronics products are not authorized for use as critical components in life support devices or systems without express written approval of STMicroelectronics.

© The ST logo is a registered trademark of STMicroelectronics

© 2002 STMicroelectronics - Printed in Italy - All Rights Reserved  
STMicroelectronics GROUP OF COMPANIES

Australia - Brazil - Canada - China - Finland - France - Germany - Hong Kong - India - Israel - Italy - Japan - Malaysia - Malta - Morocco  
Singapore - Spain - Sweden - Switzerland - United Kingdom - United States.

© <http://www.st.com>