



# STS8DNF3LL

## DUAL N-CHANNEL 30V - 0.017 Ω - 8A SO-8 LOW GATE CHARGE STripFET™ II POWER MOSFET

TYPE	V <sub>DSS</sub>	R <sub>DS(on)</sub>	I <sub>D</sub>
STS8DNF3LL	30 V	<0.020 Ω	8 A

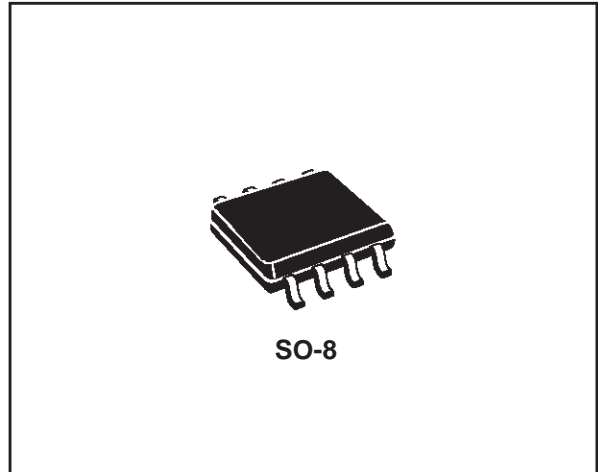
- TYPICAL R<sub>DS(on)</sub> = 0.017Ω
- OPTIMAL R<sub>DS(on)</sub> x Q<sub>g</sub> TRADE-OFF @ 4.5V
- CONDUCTION LOSSES REDUCED
- SWITCHING LOSSES REDUCED

### DESCRIPTION

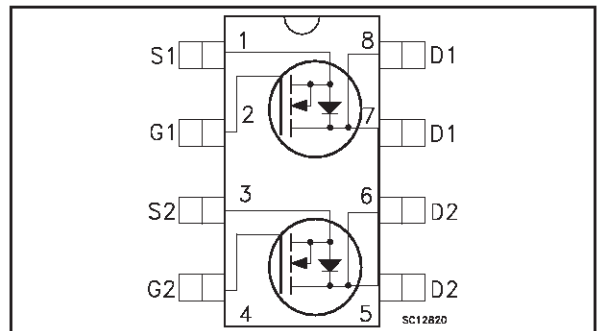
This application specific Power MOSFET is the second generation of STMicroelectronics unique "Single Feature Size™" strip-based process. The resulting transistor shows the best trade-off between on-resistance and gate charge. When used as high and low side in buck regulators, it gives the best performance in terms of both conduction and switching losses. This is extremely important for motherboards where fast switching and high efficiency are of paramount importance.

### APPLICATIONS

- SPECIFICALLY DESIGNED AND OPTIMISED FOR HIGH EFFICIENCY CPU CORE DC/DC CONVERTERS FOR MOBILE PCs



### INTERNAL SCHEMATIC DIAGRAM



### ABSOLUTE MAXIMUM RATINGS

Symbol	Parameter	Value	Unit
V <sub>DS</sub>	Drain-source Voltage (V <sub>GS</sub> = 0)	30	V
V <sub>DGR</sub>	Drain-gate Voltage (R <sub>GS</sub> = 20 kΩ)	30	V
V <sub>GS</sub>	Gate- source Voltage	± 16	V
I <sub>D</sub>	Drain Current (continuous) at T <sub>C</sub> = 25°C Single Operation	8	A
	Drain Current (continuous) at T <sub>C</sub> = 100°C Single Operation	5	
I <sub>DM</sub> (●)	Drain Current (pulsed)	32	A
P <sub>tot</sub>	Total Dissipation at T <sub>C</sub> = 25°C Dual operating	1.6	W
	Total Dissipation at T <sub>C</sub> = 25°C Single operating	2	

(●) Pulse width limited by safe operating area.

## STS8DNF3LL

### THERMAL DATA

Rthj-amb	(*)Thermal Resistance Junction-ambient	Single Operating	62.5	°C/W
		Dual Operating	78	°C/W
T <sub>j</sub>	Thermal Operating Junction-ambient		150	°C
T <sub>stg</sub>	Storage Temperature		-55 to 150	°C

(\*) When mounted on FR-4 board with 0.5 in<sup>2</sup> pad of Cu.

### ELECTRICAL CHARACTERISTICS (T<sub>case</sub> = 25 °C unless otherwise specified)

#### OFF

Symbol	Parameter	Test Conditions	Min.	Typ.	Max.	Unit
V <sub>(BR)DSS</sub>	Drain-source Breakdown Voltage	I <sub>D</sub> = 250 μA, V <sub>GS</sub> = 0	30			V
I <sub>DSS</sub>	Zero Gate Voltage Drain Current (V <sub>GS</sub> = 0)	V <sub>DS</sub> = Max Rating V <sub>DS</sub> = Max Rating T <sub>C</sub> = 125°C			1 10	μA μA
I <sub>GSS</sub>	Gate-body Leakage Current (V <sub>DS</sub> = 0)	V <sub>GS</sub> = ± 16 V			±100	nA

#### ON (\*)

Symbol	Parameter	Test Conditions	Min.	Typ.	Max.	Unit
V <sub>GS(th)</sub>	Gate Threshold Voltage	V <sub>DS</sub> = V <sub>GS</sub> I <sub>D</sub> = 250 μA	1			V
R <sub>DS(on)</sub>	Static Drain-source On Resistance	V <sub>GS</sub> = 10 V I <sub>D</sub> = 4 A V <sub>GS</sub> = 4.5 V I <sub>D</sub> = 4 A		0.017 0.020	0.020 0.024	Ω Ω

#### DYNAMIC

Symbol	Parameter	Test Conditions	Min.	Typ.	Max.	Unit
g <sub>fs</sub> (*)	Forward Transconductance	V <sub>DS</sub> =15 V I <sub>D</sub> = 4 A		12.5		S
C <sub>iss</sub>	Input Capacitance	V <sub>DS</sub> = 25V, f = 1 MHz, V <sub>GS</sub> = 0		800		pF
C <sub>oss</sub>	Output Capacitance			250		pF
C <sub>rss</sub>	Reverse Transfer Capacitance			60		pF

**ELECTRICAL CHARACTERISTICS** (continued)

**SWITCHING ON**

Symbol	Parameter	Test Conditions	Min.	Typ.	Max.	Unit
$t_{d(on)}$ $t_r$	Turn-on Delay Time Rise Time	$V_{DD} = 15\text{ V}$ $I_D = 4\text{ A}$ $R_G = 4.7\ \Omega$ $V_{GS} = 4.5\text{ V}$ (Resistive Load, Figure 1)		18 32		ns ns
$Q_g$ $Q_{gs}$ $Q_{gd}$	Total Gate Charge Gate-Source Charge Gate-Drain Charge	$V_{DD} = 15\text{ V}$ $I_D = 8\text{ A}$ $V_{GS} = 5\text{ V}$ (see test circuit, Figure 2)		12.5 3.2 4.5	17	nC nC nC

**SWITCHING OFF**

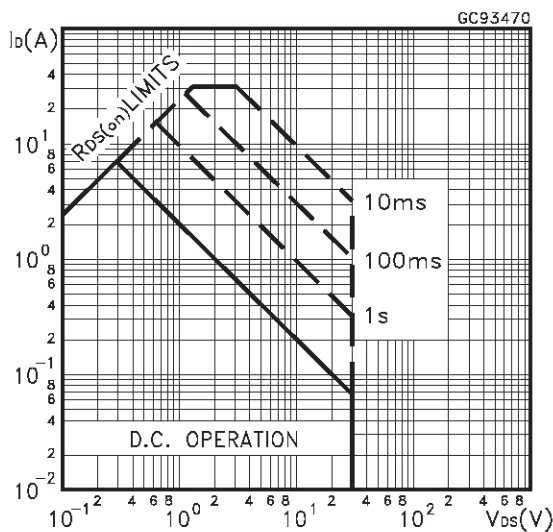
Symbol	Parameter	Test Conditions	Min.	Typ.	Max.	Unit
$t_{d(off)}$ $t_f$	Turn-off Delay Time Fall Time	$V_{DD} = 15\text{ V}$ $I_D = 4\text{ A}$ $R_G = 4.7\ \Omega$ , $V_{GS} = 4.5\text{ V}$ (Resistive Load, Figure 1)		21 11		ns ns

**SOURCE DRAIN DIODE**

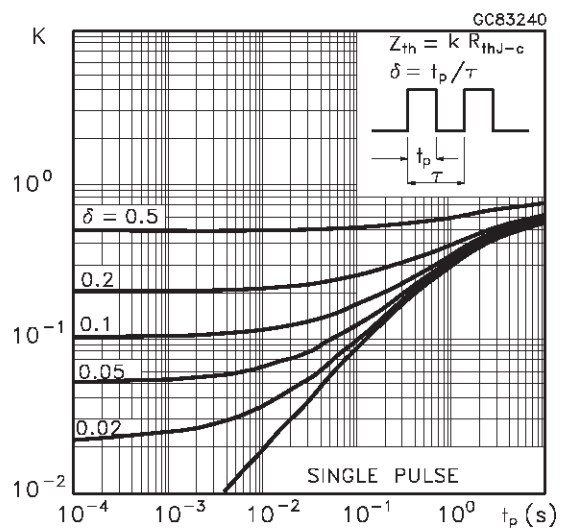
Symbol	Parameter	Test Conditions	Min.	Typ.	Max.	Unit
$I_{SD}$ $I_{SDM} (\bullet)$	Source-drain Current Source-drain Current (pulsed)				8 32	A A
$V_{SD} (*)$	Forward On Voltage	$I_{SD} = 8\text{ A}$ $V_{GS} = 0$			1.2	V
$t_{rr}$ $Q_{rr}$ $I_{RRM}$	Reverse Recovery Time Reverse Recovery Charge Reverse Recovery Current	$I_{SD} = 8\text{ A}$ $di/dt = 100\text{ A}/\mu\text{s}$ $V_{DD} = 15\text{ V}$ $T_j = 150^\circ\text{C}$ (see test circuit, Figure 3)		23 17 1.5		ns nC A

(\*)Pulsed: Pulse duration = 300  $\mu\text{s}$ , duty cycle 1.5 %.  
 (•)Pulse width limited by safe operating area.

**Safe Operating Area**

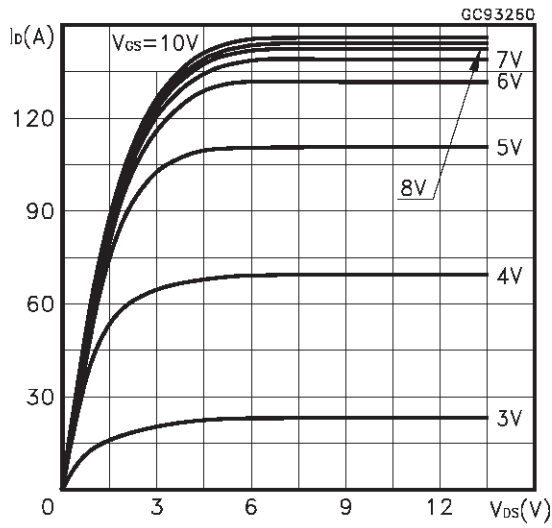


**Thermal Impedance**

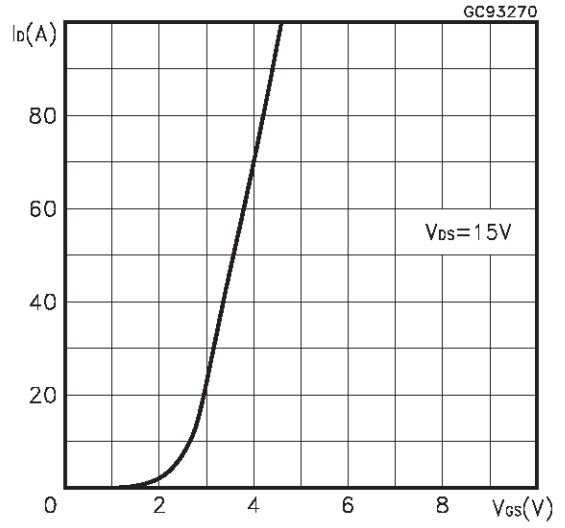


# STS8DNF3LL

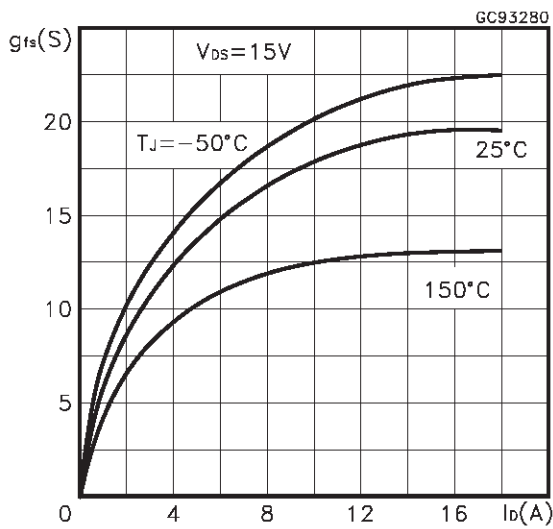
Output Characteristics



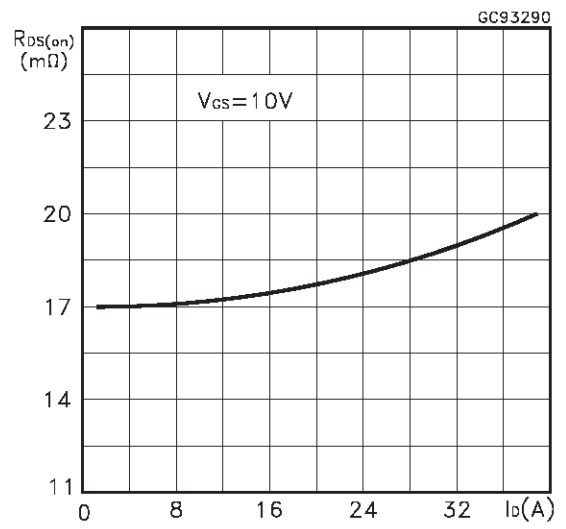
Transfer Characteristics



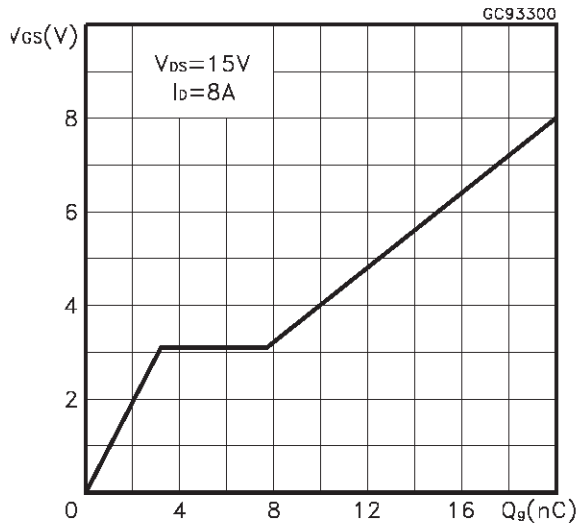
Transconductance



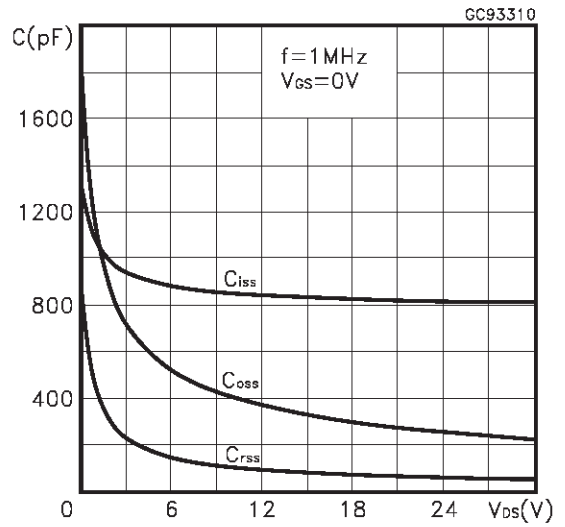
Static Drain-source On Resistance



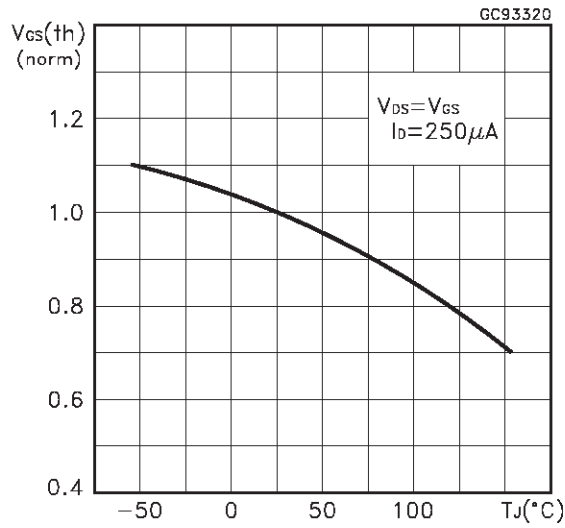
Gate Charge vs Gate-source Voltage



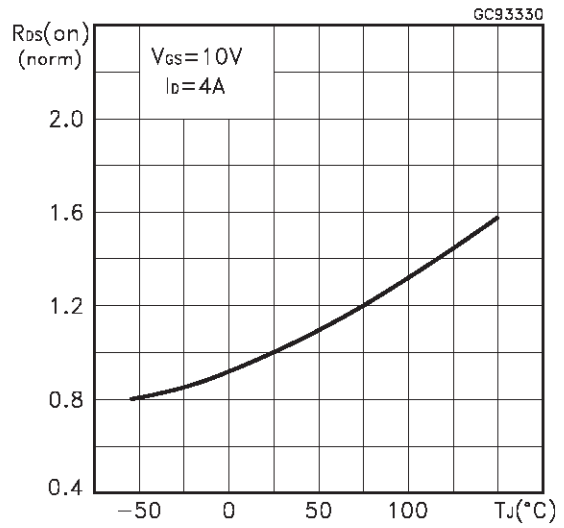
Capacitance Variations



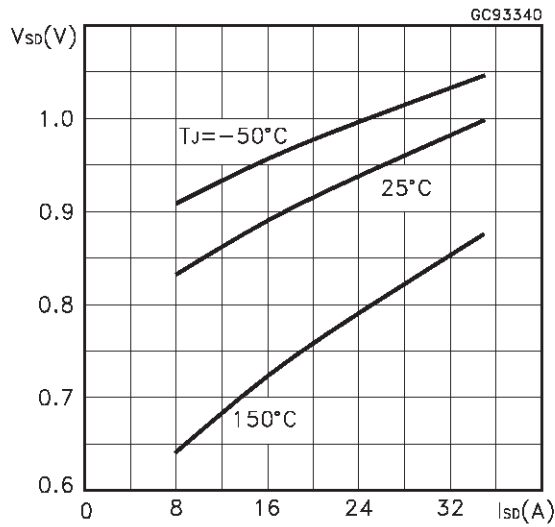
Normalized Gate Threshold Voltage vs Temperature



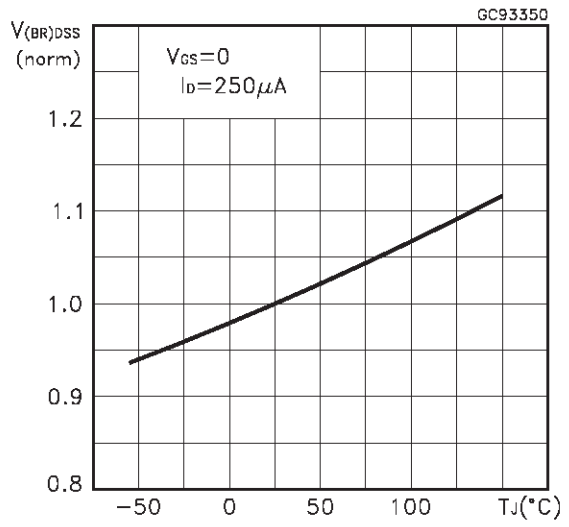
Normalized on Resistance vs Temperature



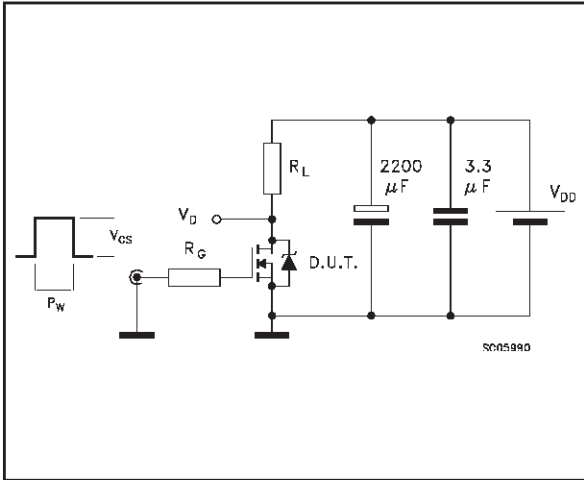
Source-drain Diode Forward Characteristics



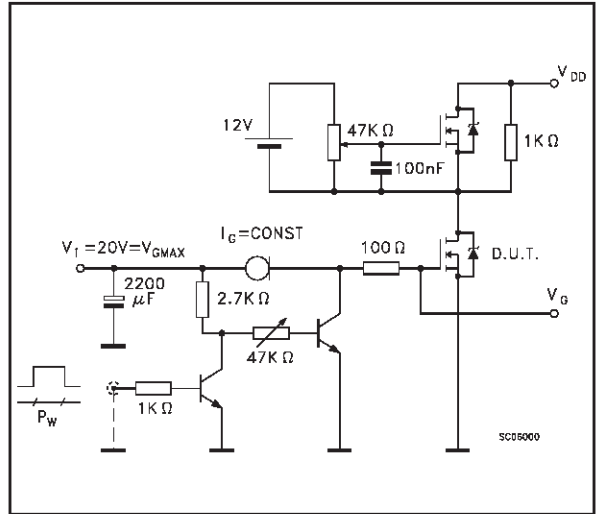
Normalized Breakdown Voltage vs Temperature.



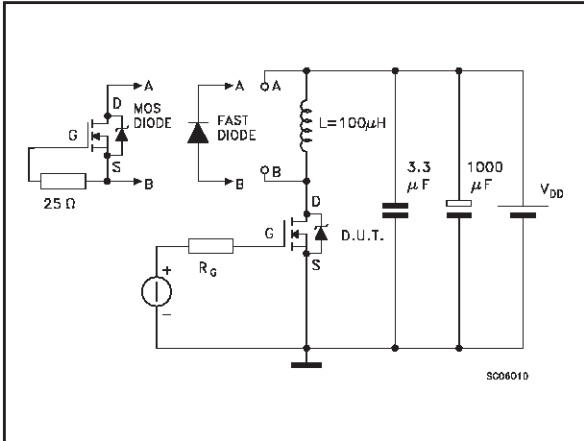
**Fig. 1: Switching Times Test Circuits For Resistive Load**



**Fig. 2: Gate Charge test Circuit**

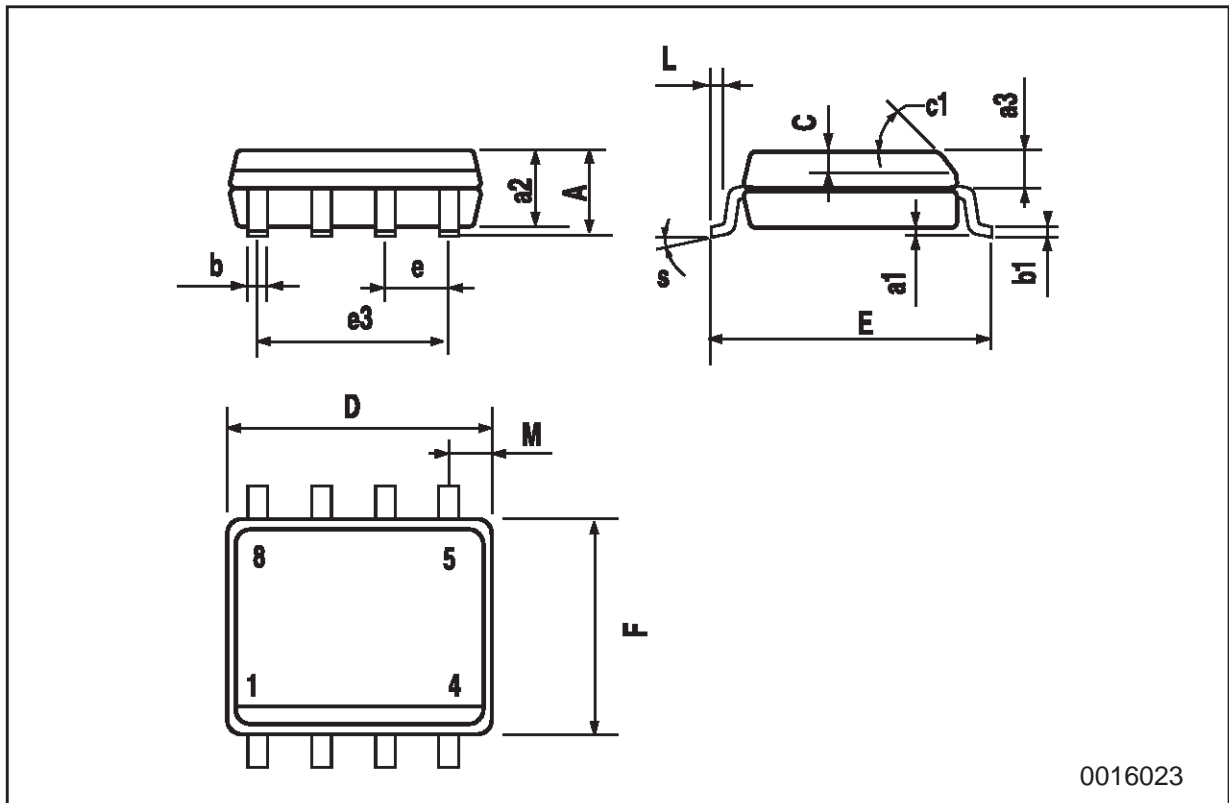


**Fig. 3: Test Circuit For Diode Recovery Behaviour**



**SO-8 MECHANICAL DATA**

DIM.	mm			inch		
	MIN.	TYP.	MAX.	MIN.	TYP.	MAX.
A			1.75			0.068
a1	0.1		0.25	0.003		0.009
a2			1.65			0.064
a3	0.65		0.85	0.025		0.033
b	0.35		0.48	0.013		0.018
b1	0.19		0.25	0.007		0.010
C	0.25		0.5	0.010		0.019
c1	45 (typ.)					
D	4.8		5.0	0.188		0.196
E	5.8		6.2	0.228		0.244
e		1.27			0.050	
e3		3.81			0.150	
F	3.8		4.0	0.14		0.157
L	0.4		1.27	0.015		0.050
M			0.6			0.023
S	8 (max.)					



0016023

Information furnished is believed to be accurate and reliable. However, STMicroelectronics assumes no responsibility for the consequences of use of such information nor for any infringement of patents or other rights of third parties which may result from its use. No license is granted by implication or otherwise under any patent or patent rights of STMicroelectronics. Specifications mentioned in this publication are subject to change without notice. This publication supersedes and replaces all information previously supplied. STMicroelectronics products are not authorized for use as critical components in life support devices or systems without express written approval of STMicroelectronics.

The ST logo is registered trademark of STMicroelectronics  
© 2002 STMicroelectronics - All Rights Reserved

All other names are the property of their respective owners.

STMicroelectronics GROUP OF COMPANIES

Australia - Brazil - Canada - China - Finland - France - Germany - Hong Kong - India - Israel - Italy - Japan - Malaysia - Malta - Morocco -  
Singapore - Spain - Sweden - Switzerland - United Kingdom - United States.

<http://www.st.com>