



ELECTRONIC CIRCUIT BREAKER

- TWO N-CHANNEL MOSFETs CONTROL AND DUAL INDEPENDENT CURRENT SUPERVISION FOR OVER CURRENT PROTECTION
- DUAL SUPPLY OPERATION
- FROM +3/-5V OPERATING VOLTAGE
- STEP-UP CONVERTER : VCC +13.5V OUTPUT VOLTAGE
- ADJUSTABLE PROTECTION MODE (CT RIP 1/2)
- SHUTDOWN OUTPUT STATUS
- FEW EXTERNAL COMPONENTS

DESCRIPTION

The TD230 is designed to control two N-channel MOSFETs used as power switches in circuit breaking applications.

Its current supervision and immediate action on the switches ensure high security for the boards and the supplies thus protected against short-circuit or over current.

In case of short-circuit or over current detection, the TD230 immediately switches off the corresponding MOSFET, thus disconnecting the board from the supply. After several automatic restart attempts, a definitive shutdown of the circuit is done if the shortcircuit or over current persists over an externally adjustable time, until the TD230 is reset by temporary INHIBIT signal or temporary switching off of the power supply (hot disconnection/reconnection).

If the board is disconnected from the positive supply by the TD230 it will automatically be disjuncted from the negative supply too.

TD230 integrates an induction step-up converter that provides 13.5V above the positive rail to drive the high side MOSFET.

ORDER CODE

Part Number	Temperature Range	Package	
		N	D
TD230I	-40°C, +125°C	•	•

N = Dual in Line Package (DIP)
D = Small Outline Package (SO)

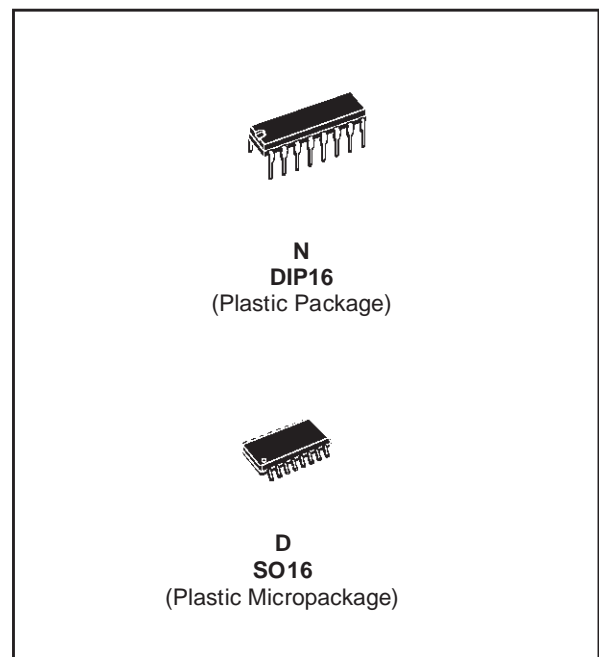

PIN CONNECTIONS (top view)

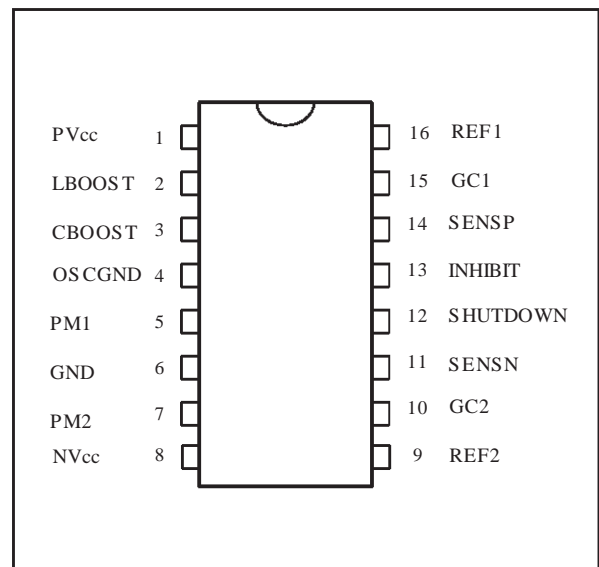

TD230

BLOCK DIAGRAM

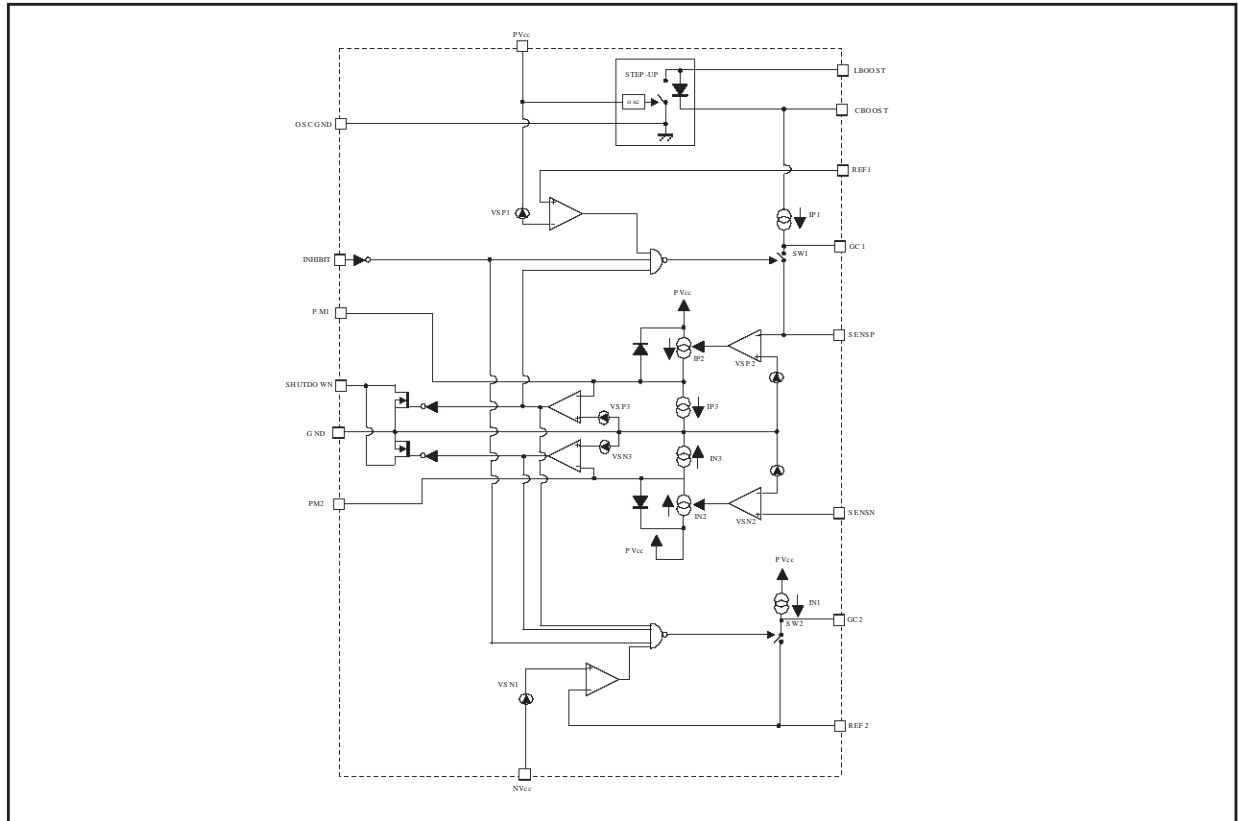

ABSOLUTE MAXIMUM RATINGS

Symbol	Parameter	Value	Unit
V_{CC}^+	Positive Supply Voltage	+22	V
V_{CC}^-	Negative Supply Voltage	-22	V
Inhibit	Input Voltage	7	V
Shutdown	Input Voltage	7	V
PM1/PM2	Input Voltage	7	V
T_j	Operating Junction Temperature	-40 to +150	°C
T_{amb}	Operating Ambient Temperature	-40 to +125	°C
T_{stg}	Storage Temperature Range	-65 to +150	°C

OPERATING CONDITIONS

Symbol	Parameter	Value	Unit
V_{CC}	Supply Voltage	±18	V

INSTRUCTION FOR USE

Symbol	Parameter	Value	Unit
C_{bypass}	Bypass Capacitor (each supply)	1	μF

ELECTRICAL CHARACTERISTICS
 $V_{CC} = \pm 5V$, $T_{amb} = 25^{\circ}C$, $L_{boost} = 220\mu H$, $C_{boost} = 100nF$ (unless otherwise specified)

Symbol	Parameter	Min.	Typ.	Max.	Unit
SUPPLY					
V_{CC}^{+}	Positive Supply Voltage	2.7		18	V
V_{CC}^{-}	Negative Supply Voltage	-18		-4.5	V
I_{CC}^{+}	Positive Supply Current Charge Pump Inactivated Charge Pump Activated $L_{boost} = 220\mu H$, $C_{boost} = 100nF$		1.8 2.3	3 4	mA
I_{CC}^{-}	Negative Supply Current Charge Pump Activated/Inactivated		-0.7	-1.5	mA
LOGIC INPUT (INHIBIT)					
V_{IH}	High Input Voltage	2		6	V
V_{IL}	Low Input Voltage	0		0.8	V
t_p	Propagation Delay GC1/2 (without load)		0.5	2	μs
LOGIC OUTPUT (SHUTDOWN-open drain)					
V_{OL}	Low Output Voltage (2mA)			0.8	V
I_{OH}	High Output Current (6V)		1		nA
t_s	Shutdown Response Time (sens P/N shutdown without load)		8	15	μs
STEP-UP CONVERTER					
V_{boost}	Step-Up Output Voltage	$V_{CC}^{+} + 10$	$V_{CC}^{+} + 13.4$	$V_{CC}^{+} + 15$	V
$t_{V_{boost}}$	Rise Time for V_{boost} (10 to 90%)		250	800	μs
V_{rip}	Output Ripple Voltage		0.15	0.5	V
INPUT COMPARATORS					
V_i	Threshold ($PV_{CC} - Ref1$, $NV_{CC} - Ref2$)	56	63	71	mV
t_{re}	Response Time (GC1/2 - without load)		2	3	μs
t_i	Inhibition Time (without load)			300	ns
VOLTAGE SOURCES					
VSP2 VSN2	Threshold Sense Pos/Neg	$0.7 V_{CC}^{\pm}$	$0.75 V_{CC}^{\pm}$	$0.8 V_{CC}^{\pm}$	V
VSP3 VSN3	Threshold Protection Mode	1.10	1.20	1.30	V
CURRENT SOURCES					
IP1, IN1	Soft Start Current Sources	10	15	20	μA
IP2, IN2	Protection Mode Current Sources (loading $C_{trip} 1/2$)	3	4	5	μA
IP3, IN3	Protection Mode Current Sources (discharging $C_{trip} 1/2$)	0.6	1	1.4	μA
SWITCHES					
R_{on}	On-Resistance of the switches - SW1/SW2		90	200	Ω

Figure 1 : DUAL ELECTRONIC CIRCUIT BREAKER APPLICATION

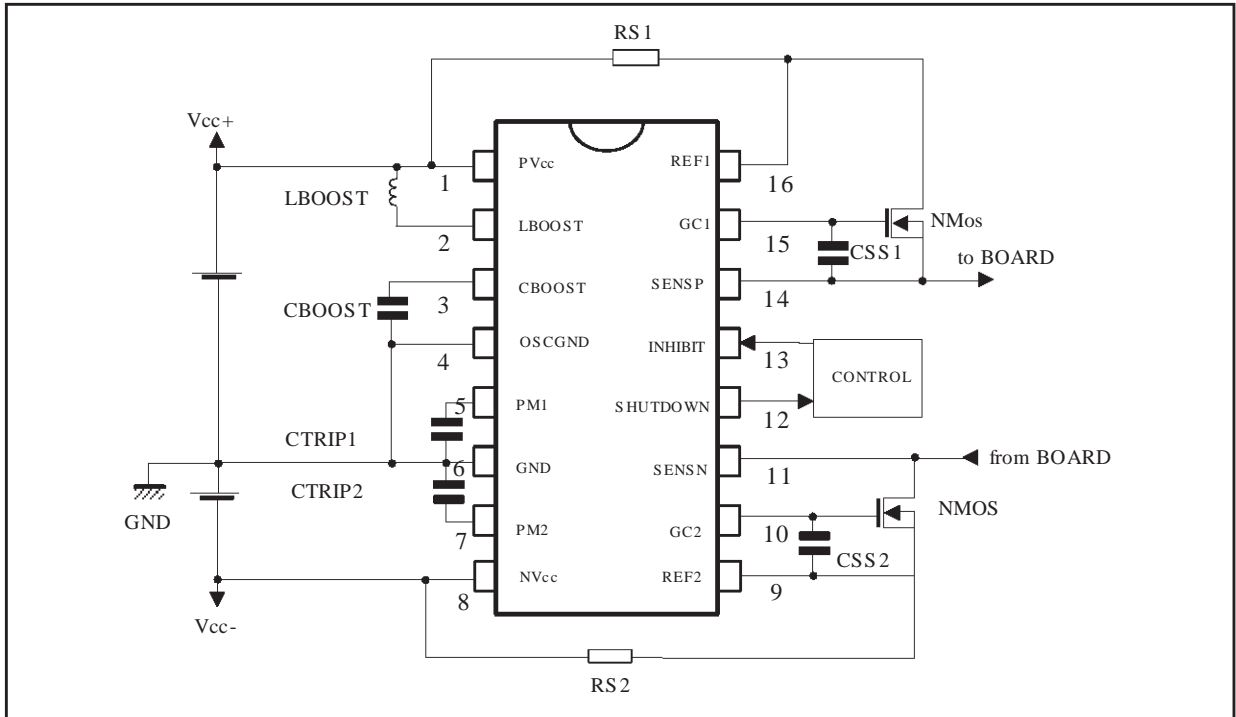
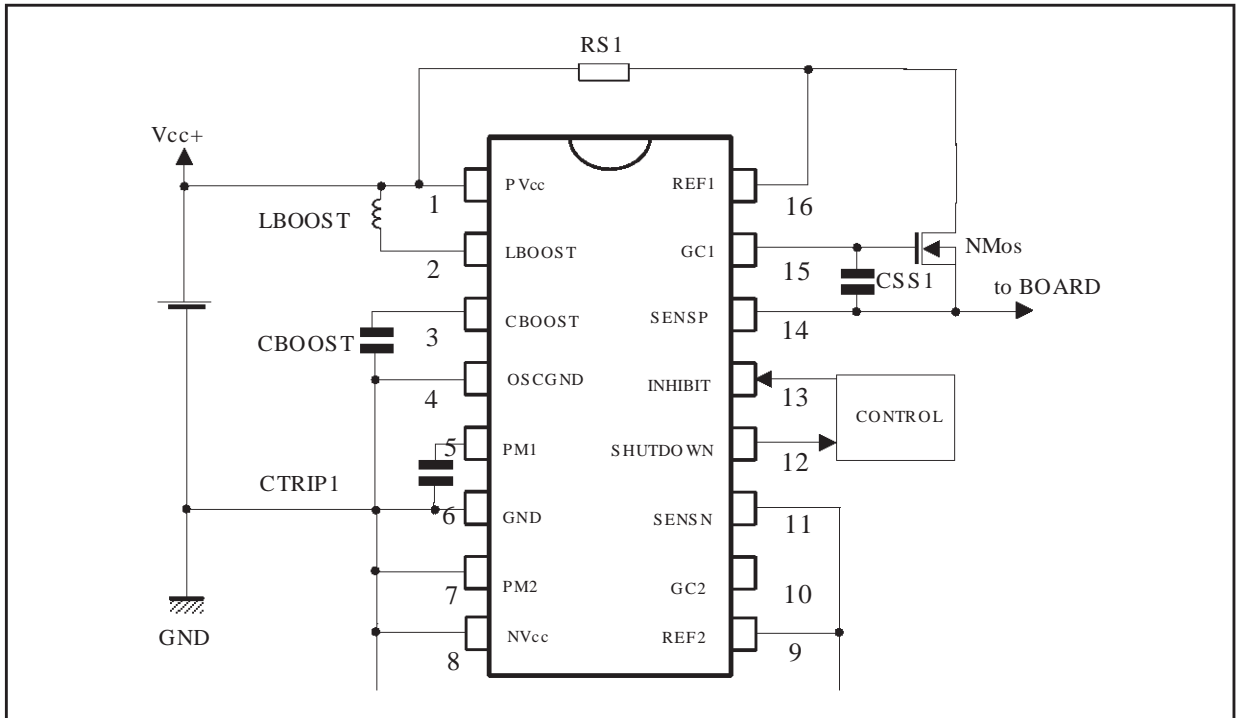
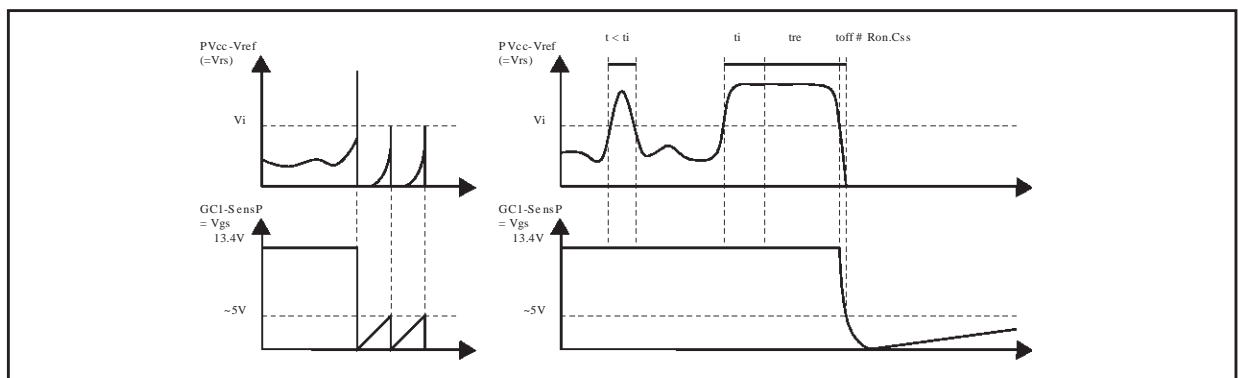
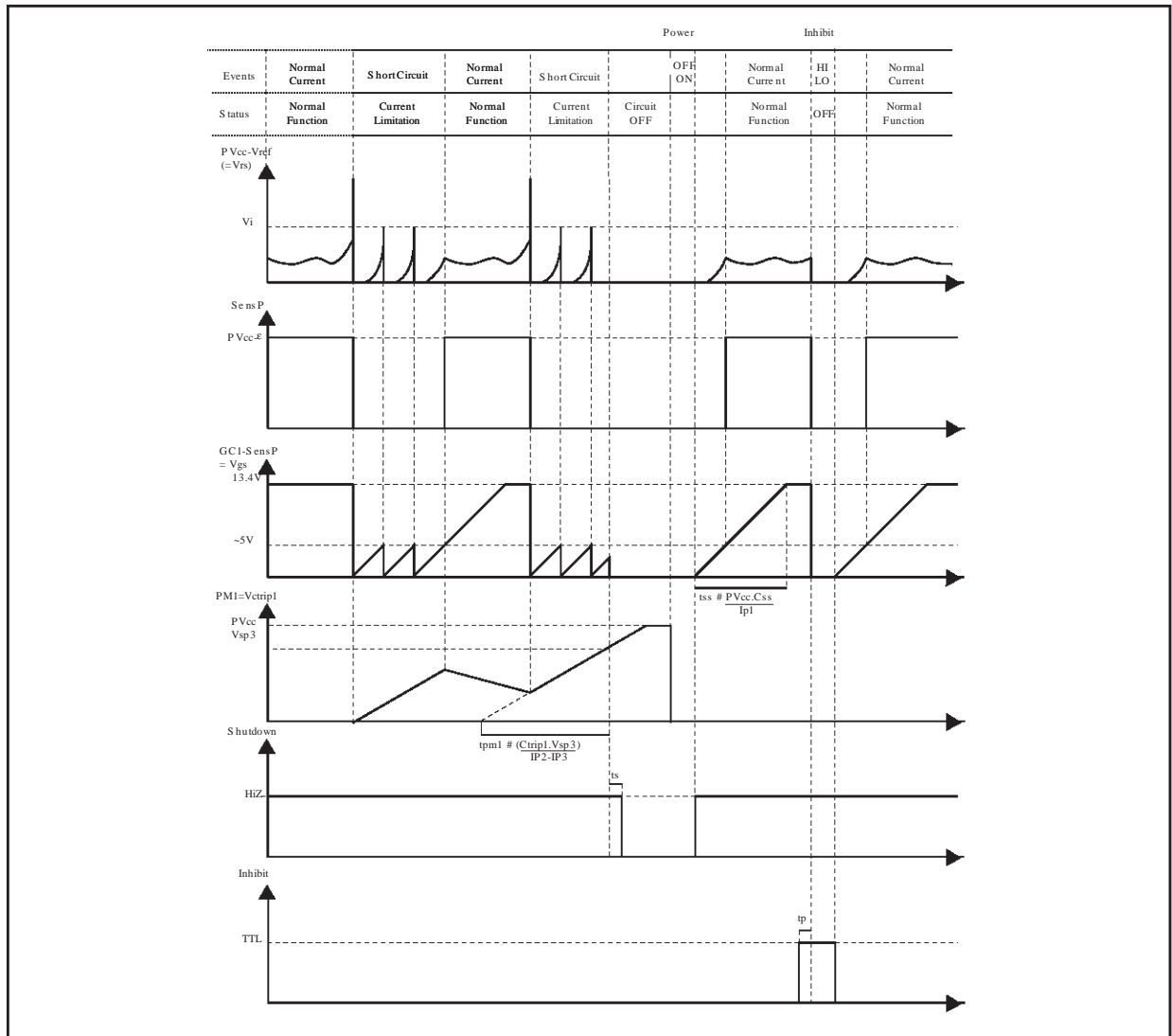

Figure 2 : SINGLE ELECTRONIC CIRCUIT BREAKER APPLICATION



TIMING DIAGRAMS



APPLICATION NOTE

ELECTRONIC CIRCUIT BREAKER

by R. LIOU

INTRODUCTION

Over current and short circuit protection is a constant concern for today's engineers. More and more applications in different segments (Telecom, Automotive, Industrial, Computer...) require always improved reliability after delivery : maintenance costs are an ever more worrying source of expenses and customers' dissatisfaction.

Alternatives for short circuit or over current protections are the fuses and the PTC (Positive Temperature Coefficient) resistors. The first are a cheap but destructive solution ; the second are tied to a time constant due to self heating which is often incompatible with the host equipment's requirements.

In both cases, a coil can be added for an efficient limitation of current surges, to the detriment of weight and volume.

None of these solutions is fully satisfactory for a reliable, immediate and non destructible short circuit and over current protection.

1. ELECTRONIC CIRCUIT BREAKER

The electronic circuit breaker TD230 is the convenient solution for any industrial who wants at the same time :

- immediate, efficient and resettable protection for his equipment
- versatility regarding different applications
- easy and quick design-in
- low component count
- low cost

The electronic circuit breaker **TD230** is to be used with a minimal amount of external and low cost components to drive one or two N-channel MOSFETs (in respectively single or dual supply applications) used as power switches between the DC power supplies and the equipments to be protected.

The **TD230** immediately reacts (3 μ s max. without load) whenever an over current is detected by switching off the corresponding MOSFET. Several automatic restart attempts are made unless the fault persists over an externally adjustable amount of time after which the power MOSFET is definitively switched off, waiting for a reset.

If the fault is detected on the positive supply, the definitive shutdown will also disconnect the negative power supply and set a warning low level on the Shutdown pin. If the fault is detected on the negative supply, the definitive shutdown will disconnect only the negative power supply, and let the positive part of the circuit undisturbed.

The whole system can be reset in three ways :

- by switching off the power supplies
- by unplugging and re-plugging the card (live insertion)
- by setting the INHIBIT pin active during a short time (allowing remote reset)

2. HOW TO USE THE TD230 ?

The typical configuration of the **TD230** - Electronic Circuit Breaker - in a dual supply topology is shown in **figure 1**.

In this configuration, both NMOS 1/2 are used as power switches which connect the equipments to the power supplies, thus ensuring low voltage drop through the ON-resistances (R_{dson}) of NMOS_{1/2}.

2.1. Current Limitation

When an over current condition (I_{OC}) is detected through the low ohmic shunt resistors $R_{S1/2}$ as given under equation (i) :

$$\square V_{RS1/2} = I_{OC} \times R_S > 63mV \text{ typ. (i)}$$

the gate of the corresponding MOSFET 1/2 is discharged immediately, thus disconnecting the board/equipment from the power supply.

Note that the over current condition is given by the constant product $I_{OC} \times R_S = 63mV$, which means that the IOC limit is directly given by the choice of the shunt resistors $R_{S1/2}$ values.

The **TD230** automatically makes restart attempts by slowly recharging the gate of the MOSFET_{1/2} with a 15 μ A typ. current source ensuring thus slow ramp with the typical time constant before reconduction shown in equation (ii) :

$$\square t_{ON} = C_{ISS} \times V_{TH} / 15\mu A \text{ (ii)}$$

where C_{ISS} is the input capacitance of the power MOSFET_{1/2} and V_{TH} , the threshold voltage of the MOSFET (typically 5V).

This reconduction time can be extended with an external soft start capacitor $C_{SS1/2}$ as shown in

figure 1 C_{ISS} will therefore simply be replaced by $C_{ISS} + C_{SS\ 1/2}$.

Figure 1 : Dual Electronic Circuit Breaker Application

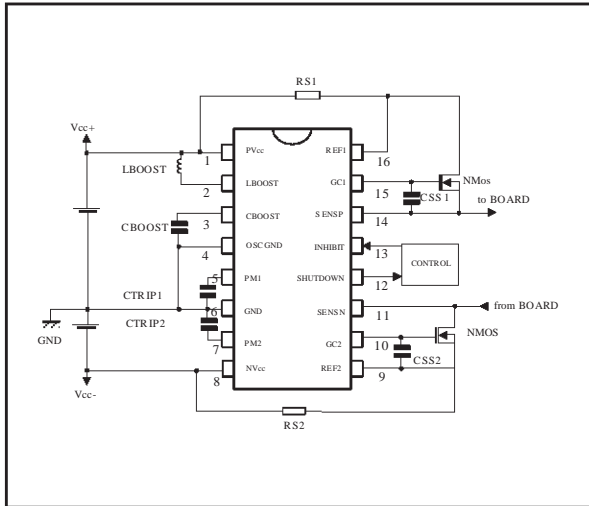

If the fault (over current condition) still remains after the reconduction state of the MOSFET_{1/2} has been reached, the current through NMOS_{1/2} will overpass the limitation given by equation (i), and the NMOS_{1/2} will immediately be switched off again.

Figure 2 shows the current limitation which is operated on every restart attempt.

Figure 2 : TD230 as Current Limitor

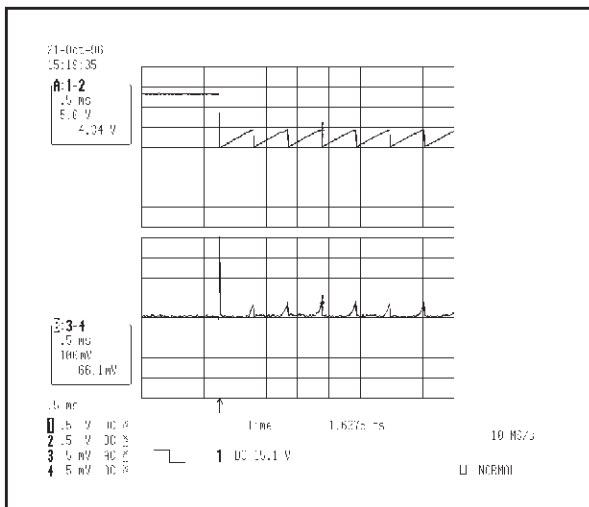

Trace A represents the Gate-Source Voltage of the Power Mosfet (0 to 13,4V).

Trace B represents the voltage across the Sense Resistor (68mΩ) in direct relation with the current through it (0 to ~1A).

Note that the first current peak which is due to an over current is limited only by the reaction time of the TD230.

This off time is tied to the value of the external soft start capacitor $C_{SS\ 1/2}$ by equation (iii) :

$$t_{OFF} = R_{DS(on)} \times C_{SS} \text{ (iii)}$$

While in current limitation mode, the NMOS_{1/2} dissipates low power due to the fact that the ON/OFF cycle time rate is very low.

Note that the higher the value of $C_{SS1/2}$ are, the more the NMOS_{1/2} will stay in linear mode during current limitation.

Note that at Power ON, or in the case of live insertion, the inrush current is automatically limited thanks to the slow gate charge of the MOSFET which switches ON softly due to the time constant given in equation (ii).

2.2. Fault Time Limitation

The repetitive switching off of the MOSFET will come to an end under two conditions :

- either the fault has disappeared, and the current through the shunt resistors $R_{S\ 1/2}$ has come back to its nominal value : the system keeps running normally.

External line defaults (lightning, line breakage, etc...) are usual causes for such temporary over currents.

- either the repetitive switching off has lasted over an externally adjustable time and the TD230 has definitively switched off the corresponding NMOS : the system waits to be reset.

Equipment faults (component short circuit, over heat, etc ...) are usual causes for lasting over currents.

This fault time supervision is done by the comparison of the output voltage to 75% of the nominal supply voltage. As soon as the output voltage is detected under $0.75 \times V_{CC} (+/-)$, the corresponding external capacitors $C_{TRIP1/2}$ is charged by a fixed current source $I_{P/N2} - I_{P/N3}$ (3μA). When the voltage across $C_{TRIP1/2}$ reaches 1.20V, the corresponding NMOS is definitively switched off and the SHUTDOWN pin is active low.

To avoid cumulative charging of the protection capacitors $C_{TRIP\ 1/2}$ in case of successive overcurrent

conditions, the capacitors $C_{TRIP\ 1/2}$ are constantly discharged by another fixed current source $I_{P/N3}$ which value is a fourth of $I_{P/N2}$ ($1\mu A$).

Figure 3 : Fault Time Limitation

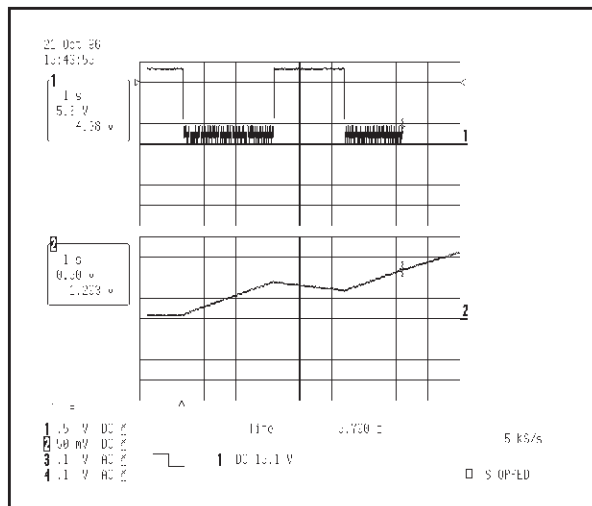

Trace 1 represents the C_{BOOST} Voltage (0 to $5+13,4 = 18,4V$)

Trace 2 represents the C_{TRIP1} Voltage.

The value of the capacitors $C_{TRIP\ 1/2}$ should be chosen in relation with the required protection time as indicated in equation (iv) :

$$\square C_{TRIP1/2} = (I_{P/N2} - I_{P/N3}) \times t_{PROTECT1/2} / VS_{PN/3}(iv)$$

where $t_{PROTECT\ 1/2}$ is the time defined by the user before a definitive resettable shutdown of MOS-FET $1/2$.

Equation (iv) can be translated to :

$$\square C_{TRIP\ 1/2} = t_{PROTECT\ 1/2} \times 3\mu A / 1.20V (iv)$$

Note that the positive power supply disjunction leads to the negative power supply disjunction, whereas the opposite is not true.

2.3. Step-Up Converter

To ensure proper voltage on the gate of the positive supply NMOS1 ($V_{GS} = 13.4V$ typ), the **TD230** integrates a step-up converter which is to be boosted with two small low cost external components : an inductor L_{BOOST} and a capacitor C_{BOOST} , as shown in **figure 4**.

Figure 4 : Step Up Converter External Components

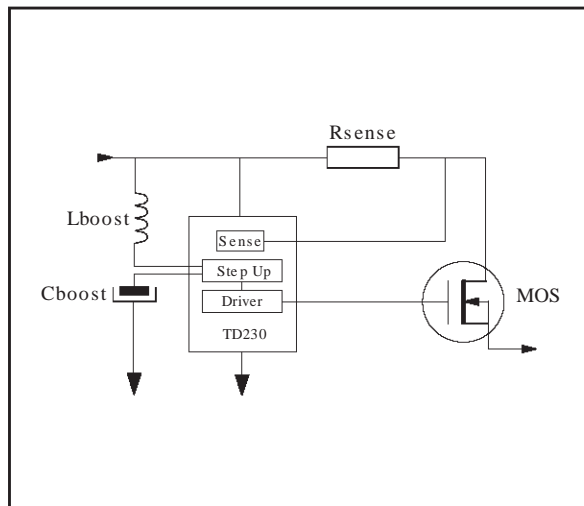

The principle of this inductive step-up converter is to pump charges in the tank capacitor C_{BOOST} following the equation (v) :

Figure 5 : Internal Step Up Schematic

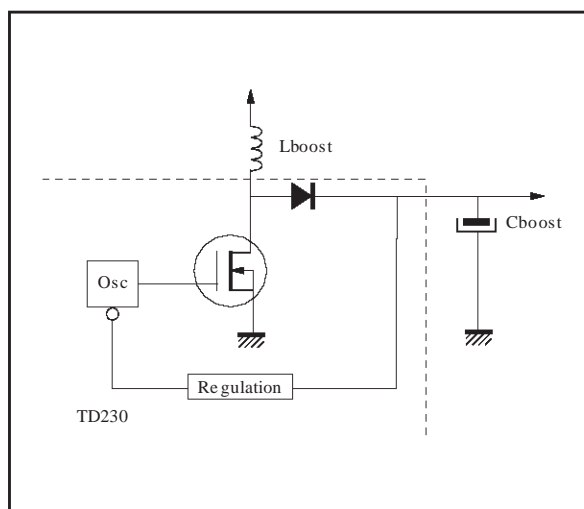

$$\square V(C_{BOOST}) = V_{CC+} + 13.4V \text{ typ (v)}$$

Charges are pumped by means of an oscillator commanded switch, and stored in the C_{BOOST} tank capacitor through a diode as shown on **figure 5**.

When the voltage across C_{BOOST} reaches $V_{CC+}+13.4V$ typ, the oscillator is stopped. This creates a ripple voltage with an amplitude of 0.2V. Note that the min and max values of $V(C_{BOOST})$ comprised between $V_{CC+} +10V$ and $V_{CC+} +15V$ already take the ripple voltage into account.

Proper operation of this step-up converter is guaranteed as low as 2.7V with a rise time (0 to 90% of $V(C_{BOOST})$) in the range of 700 μ s at 2.7V which is the worst case. At 5V, the rise time of $V(C_{BOOST})$ is 250 μ s typ. The C_{BOOST} voltage wave form at power ON under 5V supply voltage is shown on figure 6.

Figure 6 : Step Up Converter Rise Time

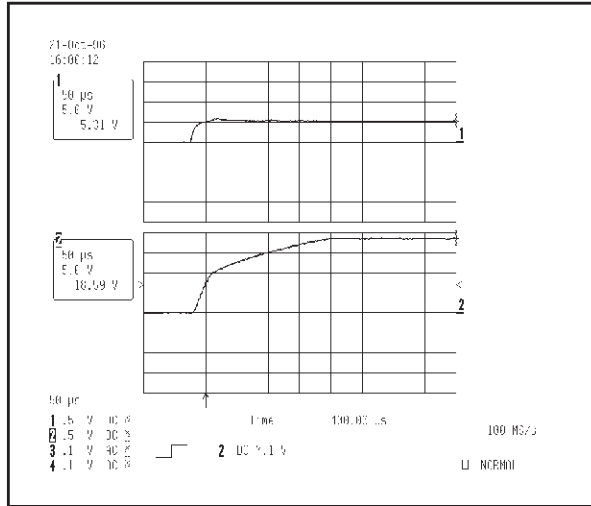

Trace 1 represents the power supply voltage (0 to 5V).

Trace 2 represents the C_{BOOST} Voltage at power ON (0 to 5+13,4 = 18,4V).

Table (a) summarizes the recommended values of the C_{BOOST} and L_{BOOST} to ensure optimized gate charge and low ripple voltage with their corresponding maximum current surge (I_{PK}) and nominal consumption (I_{CC}) of the TD230 for the most common power supply values. For each power supply value is also given the recommended value of a bypass capacitor (C_{BY}) on the power supplies.

Note that both C_{BOOST} and L_{BOOST} are available in surface mount packages.

Table (a) : Recommended values for C_{BOOST} and L_{BOOST}

V_{CC+} V	C_{BOOST} nF	L_{BOOST} μ H	I_{pk} mA	V_{rip} mV	I_{CC} mA	C_{by} μ F
2.7	47 100	68	60	190 100	5	>1
5	100	220	35	120	2.5	1
10	100 220	470	33	220 100	2.2	1
12	220	470	39	150	2.2	1
14	220	680	34	150	2.4	1
18	220	1000	31	200	2.7	1

2.4. Single Supply Breaker Application

The TD230 is perfectly suited to fit in single supplied applications (ex 0-5V), and can drive only one power MOSFET used as high side power switch.

Figure 7 shows how TD230 can be used as a single circuit breaker with the same performances.

Figure 7 : Single Electronic Circuit Breaker Application

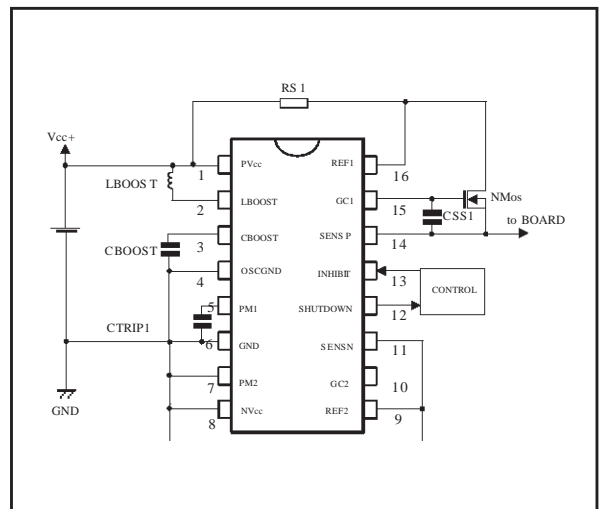

In this case, the external components consist in one boost inductor, one sense resistor, three capacitors, and one power MOSFET.

2.5. Typical Telecom Line Cards Protection Application

One of the typical applications where the TD230 can display all its technical advantages is in an exchange Telecom Cards protection. Sometimes fifty cards or more are to be supplied with the same power supply (+/-5V, 1kW), and a decentralized protection is needed because one card may be faulty, but should not penalize the others with unadapted protection system. The risk of complete breakdown of the system must be eradicated.

In this application the two above described over current causes (external line perturbation or internal component fault) are likely to happen. In the first case, the current limitation on each card will ensure undamaging on-board conditions, and in the second case, the faulty card will be disjuncted from the power supply until reset.

Figure 8 shows a typical telecom application with decentralized protection.

In this application, the positive power supply serves the logic control and analog signals whereas the negative power supply is dedicated to the analog.

Figure 8 : Decentralized Protection

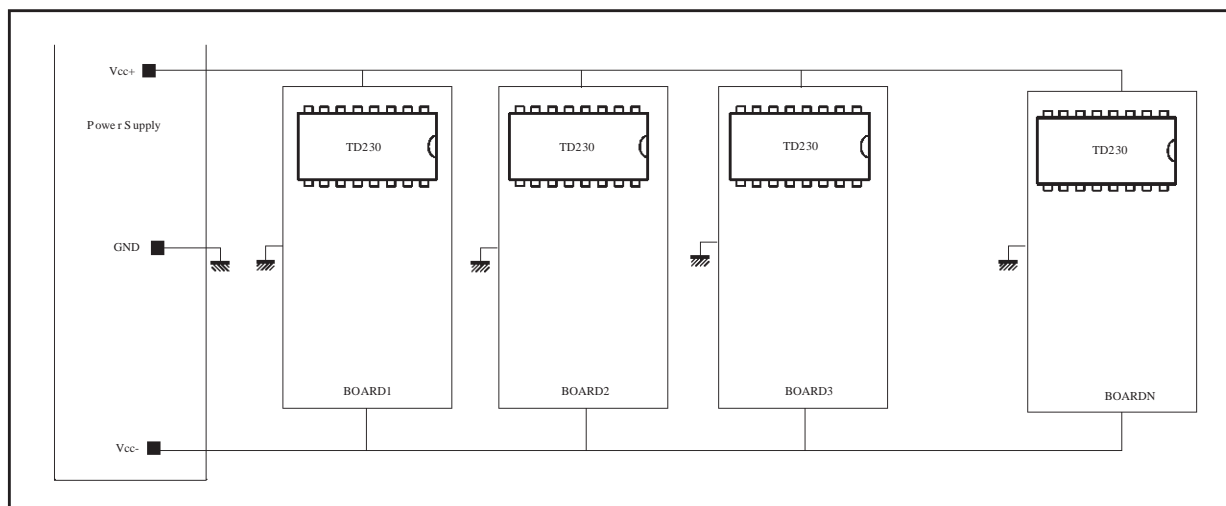

Therefore, when a fault appears on the positive rail, the definitive shutdown of the positive NMOS will lead to the shutdown of the negative NMOS, but when a fault appears on the negative rail, the definitive shutdown of the negative NMOS will have no effect on the positive NMOS.

Several possibilities are offered to reset the whole system when it has been led to definitive shutdown :

- the card can be unplugged and plugged back (live insertion)
- the INHIBIT pin can be set to active state during a short time (100 μ s typ or more) in the case of remote control facilities

3. PERFORMANCES AND EVALUATION

All the curves shown in this application note have been realized with the TD230 Evaluation Board.

The external conditions and components were as listed hereafter :

- $V_{CC}^+ = 5V$
- $V_{CC}^- = -5V$
- Suppliable output short circuit current = 5A
- IC = TD230
- MOSFET 1 = BUZ71
- MOSFET 2 = BUZ71
- $L_{BOOST} = 220\mu H$
- $C_{BOOST} = 100nF$
- $C_{TRIP1} = 10\mu F$
- $C_{TRIP2} = 10\mu F$
- $R_{S1} = 68m\Omega$
- $R_{S2} = 68m\Omega$
- $C_{SS1} = 1nF$

- $C_{SS2} = 1nF$
- Positive Bypass = 4.7 μF (plastic)
- Negative Bypass = 4.7 μF (plastic)

The evaluation board is available and allows to test the performances of the **TD230**. The layout and schematic of this evaluation board are given on **figures 9A-9B-9C**.

4. CAUTIONS

For proper use of the **TD230** as a reliable protection device, a few precautions must be taken :

1. Proper bypass capacitors must be connected as close as possible to the power pins of the **TD230** (PV_{CC} , NV_{CC} , GND). Some recommended values are given in table (a).
2. The OSCGND pin must be tied to the GND pin externally (printed board) to ensure proper step-up converter reference. If not, the step-up converter will not start.
3. The INHIBIT pin is a CMOS/TTL compatible input which should therefore not be left unconnected. The absolute maximum rating of this input is 7V. It should be tied to the TTL compatible output of an eventual control block, or, if it should not be used, tied to the GND pin.

Figure 9A: PCB (not to scale)

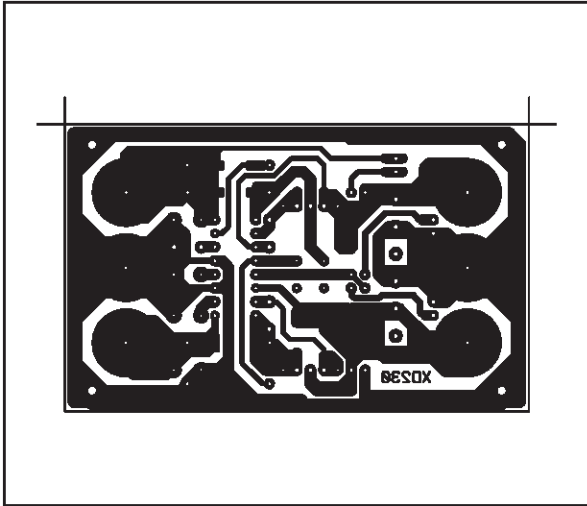

Figure 9B : Silkscreen

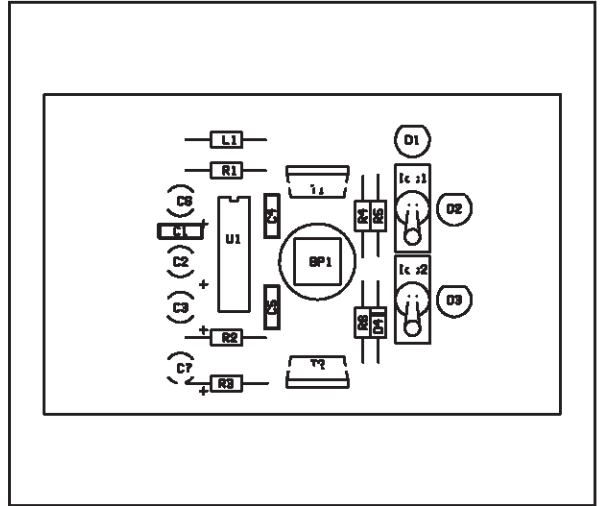
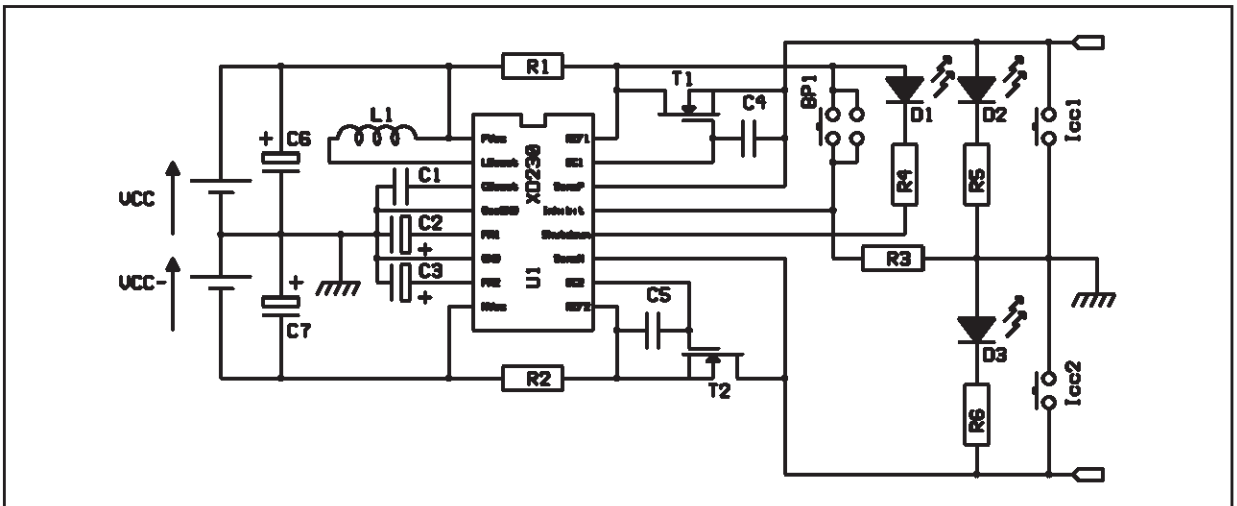

Figure 9C: Schematic



4. The SHUTDOWN pin is an open drain CMOS/TTL compatible output which should be tied to the TTL compatible input of an eventual control block. The absolute maximum rating of this output is 7V. In the case of a visual alarm, a LED is likely to be tied to the positive power supply which can be destructive for the Shutdown output if the power supply is over 7V. An easy way to eliminate this is to add a 6V zener diode between the Shutdown output and the Ground as shown on **figure 10**.

5. The time constant of the protection mode (given by the charge of $C_{TRIP1/2}$ capacitors) must be greater than the time constant of the restart attempts (given by the charge of the $C_{SS1/2}$ soft start capacitors). This condition can be described as follows :

$$\square V_{SP1/2} \times C_{TRIP1/2} / I_{P/N2} > V_{TH1/2} \times (C_{SS1/2} + C_{ISS1/2}) / I_{P/N1}$$

Figure 10 : Visual Alarm-Shutdown

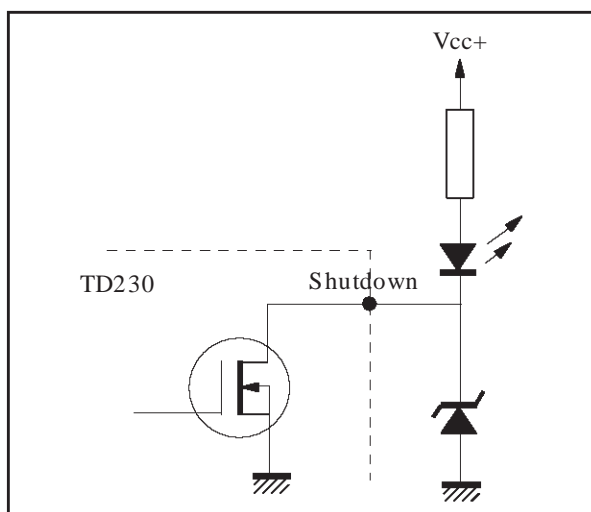

where $C_{ISS1/2}$, $C_{SS1/2}$, $V_{TH1/2}$, $I_{P/N1}$ are respectively the input capacitance, the soft start capacitor, the threshold voltage and the internal gate current sources of $NMOS_{1/2}$; and where $V_{SP1/2}$, $C_{TRIP1/2}$, $I_{P/N2}$ are respectively the voltage source, current source and external capacitor of the protection mode pins $PM_{1/2}$. Considering the typical values of $V_{SP1/2}$, $I_{P/N2}$, $I_{P/N1}$, and the fact that classical power MOSFETs have a threshold voltage around 5V, this condition can be translated to inequation (vi) :

$$\square C_{TRIP1/2} > 0.8 \times (C_{SS1/2} + C_{ISS}) \quad (vi)$$

If $C_{ISS} = 1nF$ and $C_{SS1/2} = 4.7nF$, $C_{TRIP1/2}$ should be superior to 4.56nF.

Table (b) summarizes Protection Mode Time Constants corresponding to different $C_{TRIP1/2}$ values.

Table (b) : Protection Mode Time Constants

$C_{TRIP1/2}$	Time Constant Range for Protection Mode - Shutdown -
22nF	#10ms
220nF	#100ms
2.2 μ F	#1s
22 μ F	#10s

5. ENHANCEMENTS

The performances of TD230 are well adapted to most of the circuit breaking applications in many different industry segments (Telecom, Automotive, Industrial, Computer etc...), but in the case of very demanding environment, or outstanding features, the few following advices may be helpful.

5.1. Step-Up Noise Reduction

The inductive step-up converter inevitably generates current peaks in the output of the power

switch which, in most cases are, are not worrying. But in some very demanding applications, it is necessary to remove this noise.

A good way to eliminate such peaks is to add a resistor connected in series with the inductance and an electrolytic capacitor between the common point of resistor and inductance, and ground of the Step-Up Converter as shown on figure 11.

Figure 11 : Step Up Noise Reduction

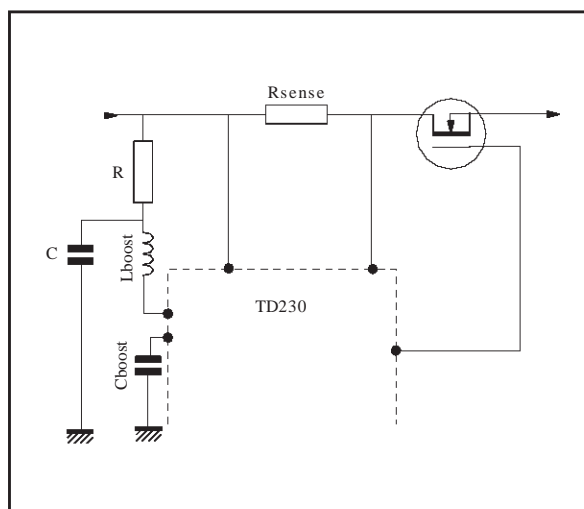

The resistor's voltage drop will be due to the product of the average consumption current with the resistor's value and the inductive current peaks will be totally absorbed by the capacitor. With a 100 Ω resistor, the voltage drop is negligible and the attenuation good with a 4.7 μ F as shown on figure 12.

Figure 12 : Step Up Noise Reductio

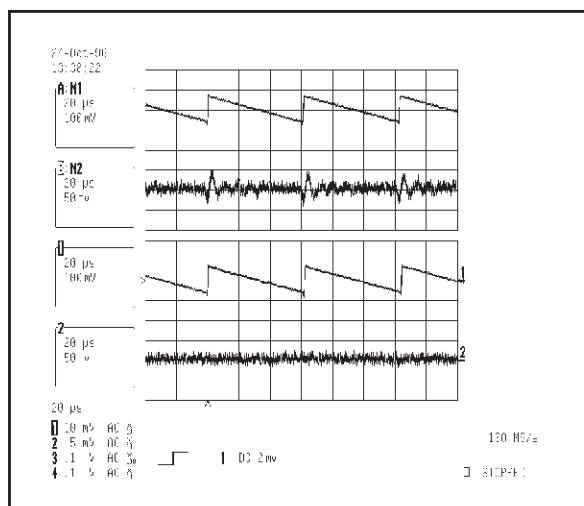

Trace A represents the ripple voltage on C_{BOOST} (200mV width).

Trace B represents the voltage perturbation due to the Step-Up converter on the output (source of the power Mosfet = Board power supply).

Traces 1 and 2 represent the same, but improved thanks to the Step-Up Noise reduction RC.

5.2. Precision Enhancement

If the system needs accurate current limitation in an environment subject to very wide temperature-variations, a good way to compensate fluctuations due to temperature variations is to use a CTN as described in **figure 13**.

Figure 13 : Wide Temperature Variations

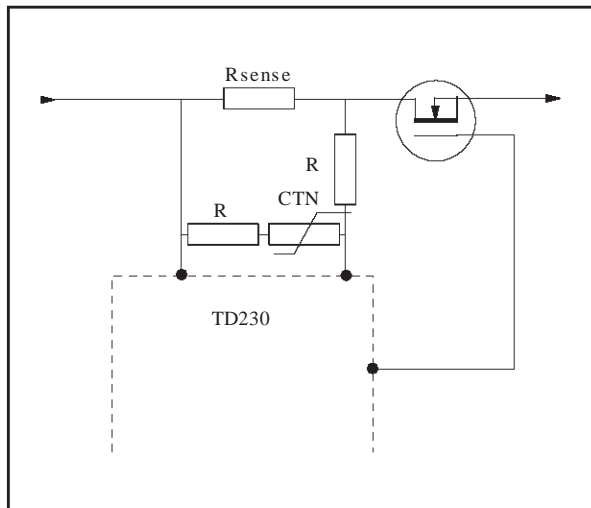

5.3. Temporisation

In some cases, it can be useful to let short current peaks pass without reaction of the breaker, though these are of higher value than the fixed current limit.

This enables the Electronic Circuit Breaker to behave as a thermal disjonctor.

This behaviour can easily be given by adding an RC constant as shown on **figure 14**.

Figure 14 : Temporisation

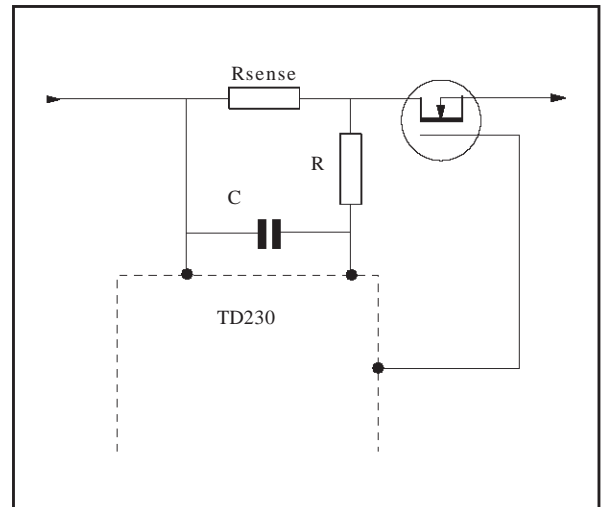

PACKAGE MECHANICAL DATA
16 PINS - PLASTIC DIP

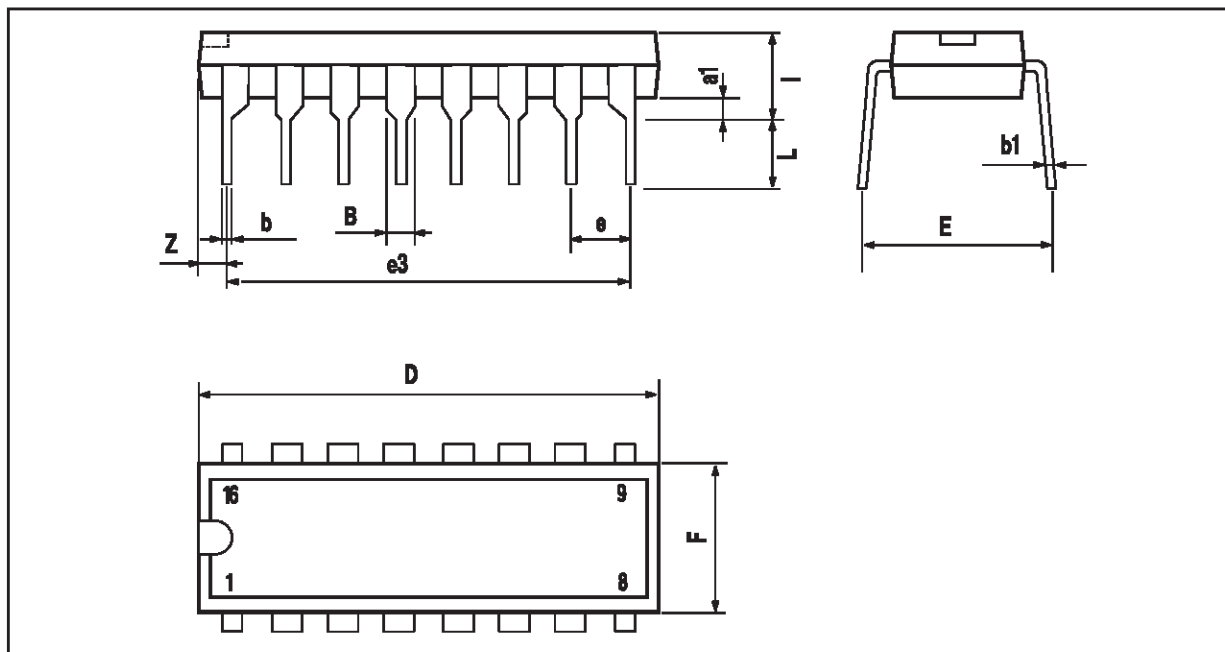

Dimensions	Millimeters			Inches		
	Min.	Typ.	Max.	Min.	Typ.	Max.
a1	0.51			0.020		
B	0.77		1.65	0.030		0.065
b		0.5			0.020	
b1		0.25			0.010	
D			20			0.787
E		8.5			0.335	
e		2.54			0.100	
e3		17.78			0.700	
F			7.1			0.280
i			5.1			0.201
L		3.3			0.130	
Z			1.27			0.050

PACKAGE MECHANICAL DATA
 16 PINS - PLASTIC MICROPACKAGE (SO)

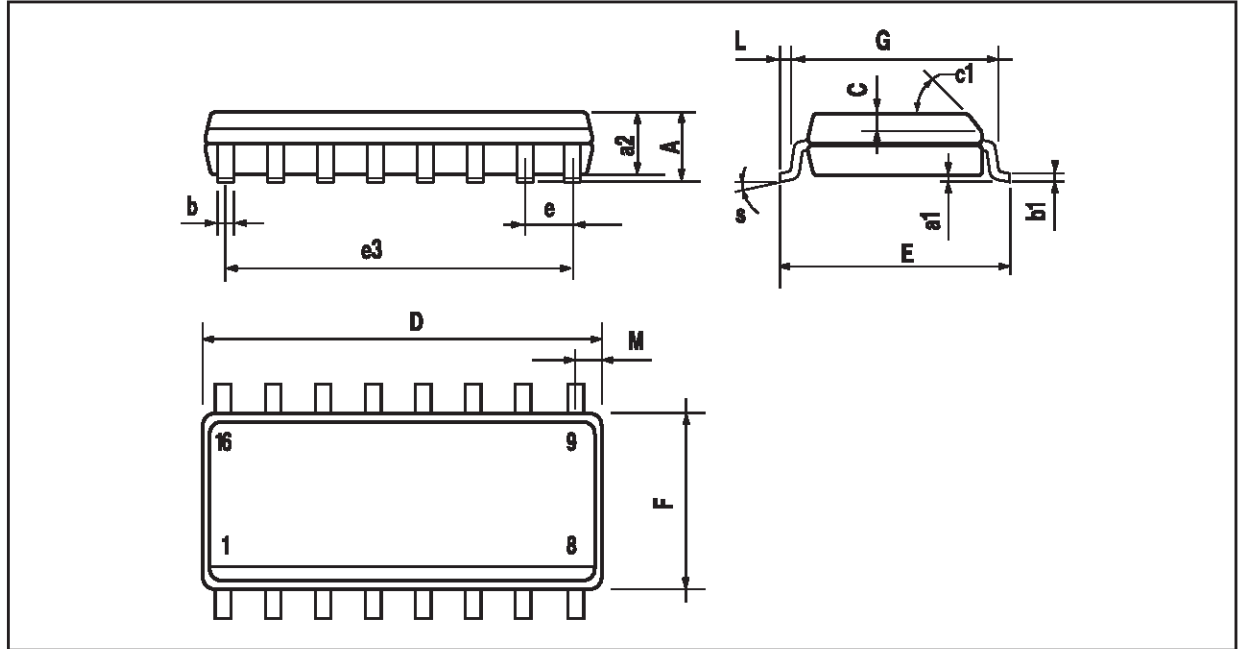

Dimensions	Millimeters			Inches		
	Min.	Typ.	Max.	Min.	Typ.	Max.
A			1.75			0.069
a1	0.1		0.2	0.004		0.008
a2			1.6			0.063
b	0.35		0.46	0.014		0.018
b1	0.19		0.25	0.007		0.010
C		0.5			0.020	
c1	45° (typ.)					
D	9.8		10	0.386		0.394
E	5.8		6.2	0.228		0.244
e		1.27			0.050	
e3		8.89			0.350	
F	3.8		4.0	0.150		0.157
G	4.6		5.3	0.181		0.209
L	0.5		1.27	0.020		0.050
M			0.62			0.024
S	8° (max.)					

Information furnished is believed to be accurate and reliable. However, STMicroelectronics assumes no responsibility for the consequences of use of such information nor for any infringement of patents or other rights of third parties which may result from its use. No license is granted by implication or otherwise under any patent or patent rights of STMicroelectronics. Specifications mentioned in this publication are subject to change without notice. This publication supersedes and replaces all information previously supplied. STMicroelectronics products are not authorized for use as critical components in life support devices or systems without express written approval of STMicroelectronics.

© The ST logo is a registered trademark of STMicroelectronics

© 2000 STMicroelectronics - Printed in Italy - All Rights Reserved
 STMicroelectronics GROUP OF COMPANIES

Australia - Brazil - China - Finland - France - Germany - Hong Kong - India - Italy - Japan - Malaysia - Malta - Morocco
 Singapore - Spain - Sweden - Switzerland - United Kingdom

© <http://www.st.com>