



TSH321

WIDE BANDWIDTH AND MOS INPUT SINGLE OPERATIONAL AMPLIFIER

- LOW DISTORTION
- GAIN BANDWIDTH PRODUCT : 300MHz
- GAIN OF 2 STABILITY
- SLEW RATE : 400V/ μ s
- VERY FAST SETTLING TIME : 60ns (0.1%)
- VERY HIGH INPUT IMPEDANCE

DESCRIPTION

The TSH321 is a wideband monolithic operational amplifier, requiring a minimum close loop gain of 2 for stability.

The TSH321 features extremely high input impedance (typically greater than $10^{12}\Omega$) allowing direct interfacing with high impedance sources.

Low distortion, wide bandwidth and high linearity make this amplifier suitable for RF and video applications. Short circuit protection is provided by an internal current-limiting circuit.

The TSH321 has internal electrostatic discharge (ESD) protection circuits and fulfills MILSTD883C-Class2.

ORDER CODE

Part Number	Temperature Range	Package
		D
TSH321I	-40°C, +125°C	•

D = Small Outline Package (SO) - also available in Tape & Reel (DT)

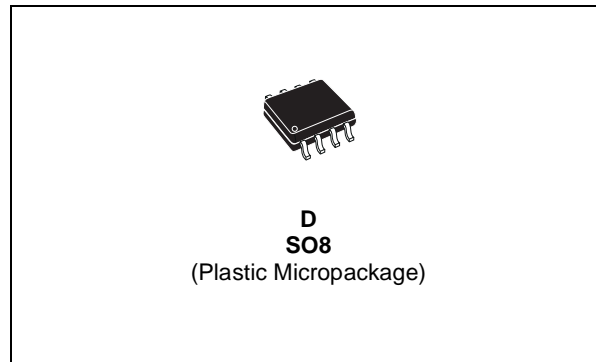

PIN CONNECTIONS (top view)

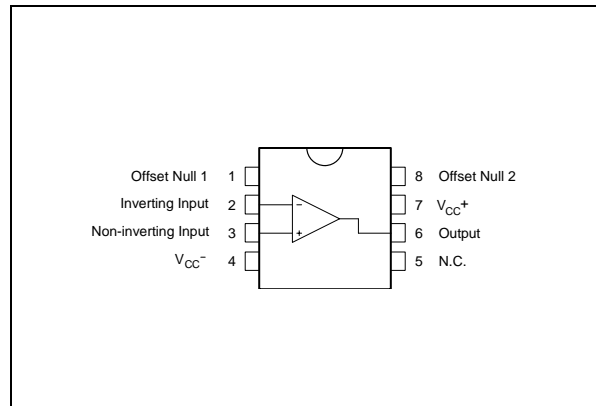

SCHEMATIC DIAGRAM

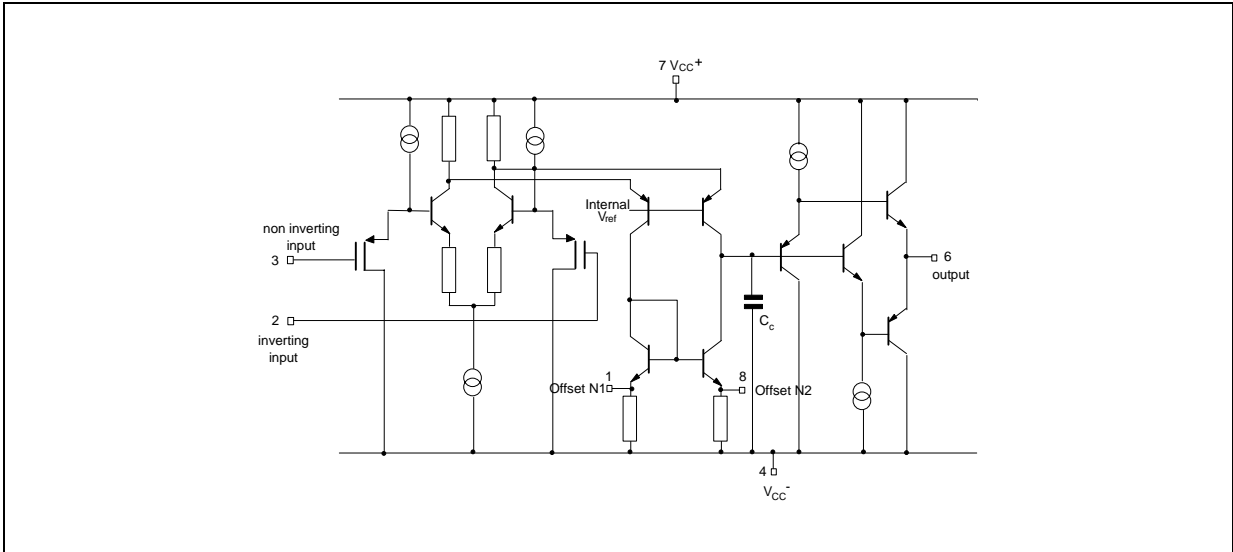

INPUT OFFSET VOLTAGE NULL CIRCUIT

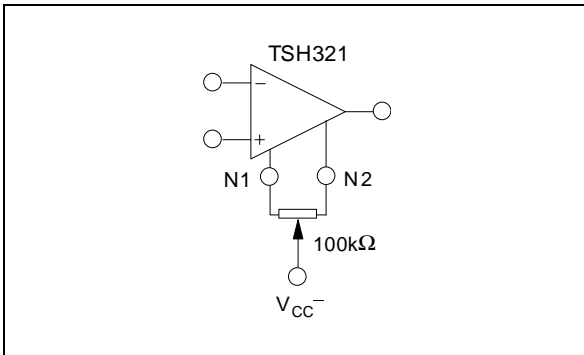

MAXIMUM RATINGS

Symbol	Parameter	Value	Unit
V_{CC}	Supply Voltage	± 7	V
V_{id}	Differential Input Voltage	± 5	V
V_i	Input Voltage	± 5	V
I_{in}	Current On Offset Null Pins	± 20	μA
T_{oper}	Operating Free-Air Temperature range	-40 to +125	$^{\circ}C$

OPERATING CONDITIONS

Symbol	Parameter	Value	Unit
V_{CC}	Supply Voltage	± 3 to ± 6	V
V_{ic}	Common Mode Input Voltage Range	V_{CC-} to $V_{CC+} - 3$	V

ELECTRICAL CHARACTERISTICS $V_{CC} = \pm 5V$, $T_{amb} = 25^{\circ}C$ (unless otherwise specified)

Symbol	Parameter	Min.	Typ.	Max.	Unit
V_{io}	Input Offset Voltage $T_{min.} \leq T_{amb} \leq T_{max}$		0.5	10 12	mV
DV_{io}	Input Offset Voltage Drift $T_{min.} \leq T_{amb} \leq T_{max.}$		10		$\mu V/^{\circ}C$
I_{ib}	Input Bias Current		2	300	pA
I_{io}	Input Offset Current		2	200	pA
I_{CC}	Supply Current, no load $T_{min.} \leq T_{amb} \leq T_{max}$ $V_{CC} = \pm 5V$ $V_{CC} = \pm 3V$ $V_{CC} = \pm 6V$ $V_{CC} = \pm 5V$		23 21 25	30 28 40 32	mA
A_{vd}	Large Signal Voltage Gain $V_o = \pm 2.5V$ $R_L = \infty$ $R_L = 100\Omega$ $R_L = 50\Omega$	800 300 200	1300 850 650		V/V
V_{icm}	Input Common Mode Voltage Range	-5 to +2	-5.5 to +2.5		V
CMR	Common-mode Rejection Ratio $V_{ic} = V_{icm min.}$	60	100		dB
SVR	Supply Voltage Rejection Ratio $V_{CC} = \pm 5V$ to $\pm 3V$	50	70		dB
V_o	Output Voltage $R_L = 100\Omega$ $R_L = 50\Omega$ $T_{min.} \leq T_{amb} \leq T_{max}$ $R_L = 100\Omega$ $R_L = 50\Omega$	± 3 ± 2.8 ± 2.9 ± 2.7	+3.5 -3.7 +3.3 -3.5		V
I_o	Output Short Circuit Current $V_{id} = \pm 1V$, $V_o = 0V$	± 50	± 100		mA
GBP	Gain Bandwidth Product $A_{VCL} = 100$, $R_L = 100\Omega$, $C_L = 15pF$, $f = 7.5MHz$		300		MHz
SR	Slew Rate $V_{in} = \pm 1V$, $A_{VCL} = 2$, $R_L = 100\Omega$, $C_L = 15pF$	200	400		V/ μs
e_n	Equivalent Input Voltage Noise $R_s = 50\Omega$ $f_o = 1kHz$ $f_o = 10kHz$ $f_o = 100kHz$ $f_o = 1MHz$		20 18.2 18.1 18.2		nV/ \sqrt{Hz}
K_{ov}	Overshoot $V_{in} = \pm 1V$, $A_{VCL} = 2$, $R_L = 100\Omega$, $C_L = 15pF$		15		%
t_s	Settling Time 0.1% ¹⁾ $V_{in} = \pm 1V$, $A_{VCL} = -1$		60		ns
t_r , t_f	Rise and Fall Time (see note 1) $V_{in} = \pm 100mV$, $A_{VCL} = 2$		2		ns
t_d	Delay Time (see note 1) $V_{in} = \pm 100mV$, $A_{VCL} = 2$		2		ns
ϕ_m	Phase Margin $A_{VM} = 2$, $R_L = 100\Omega$, $C_L = 15pF$		45		Degrees
THD	Total Harmonic Distortion $A_{VCL} = 10$, $f = 1kHz$, $V_o = \pm 2.5V$, no load		0.02		%
FPB	Full Power Bandwidth ²⁾ $V_o = 5V_{pp}$, $R_L = 100\Omega$ $V_o = 2V_{pp}$, $R_L = 100\Omega$		26 64		MHz

1. See test waveform figure

2. Full power bandwidth = $\frac{SR}{\pi V_{opp}}$

TEST WAVEFORM

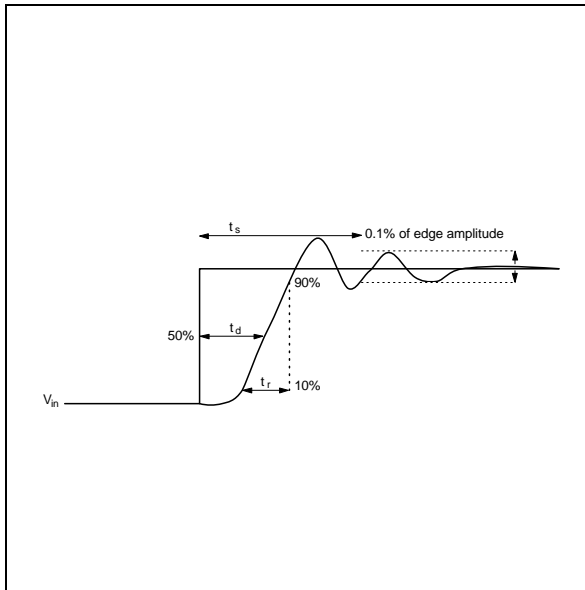

PRINTED CIRCUIT LAYOUT

As for any high frequency device, a few rules must be observed when designing the PCB to get the best performances from this high speed op amp.

From the most to the least important points :

- Each power supply lead has to be bypassed with a 10nF ceramic capacitor very close to the device and a 10 μ F tantalum capacitor.
- To provide low inductance and low resistance common return, use a ground plane or common point return for power and signal.
- All leads must be wide and as short as possible especially for op amp inputs. This is in

EVALUATION CIRCUIT

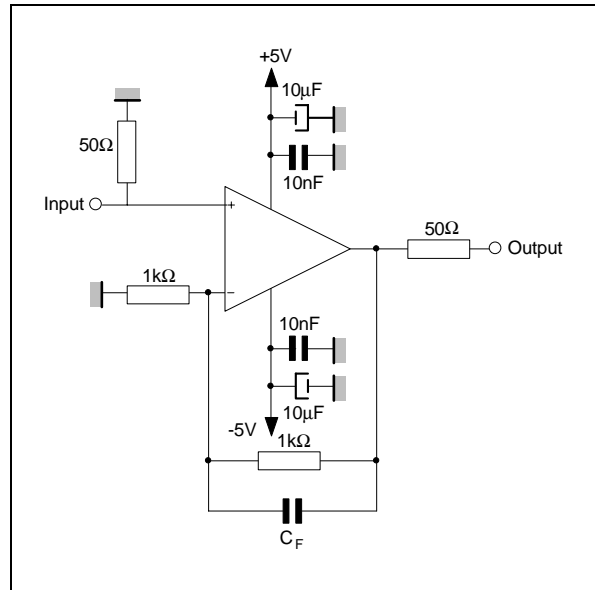

order to decrease parasitic capacitance and inductance.

- Use small resistor values to decrease time constant with parasitic capacitance.
- Choose component sizes as small as possible (SMD).
- On output, decrease capacitor load so as to avoid circuit stability being degraded which may cause oscillation. You can also add a serial resistor in order to minimise its influence.
- One can add in parallel with feedback resistor a few pF ceramic capacitor C_F adjusted to optimize the settling time.

PACKAGE MECHANICAL DATA
8 PINS - PLASTIC MICROPACKAGE (SO)

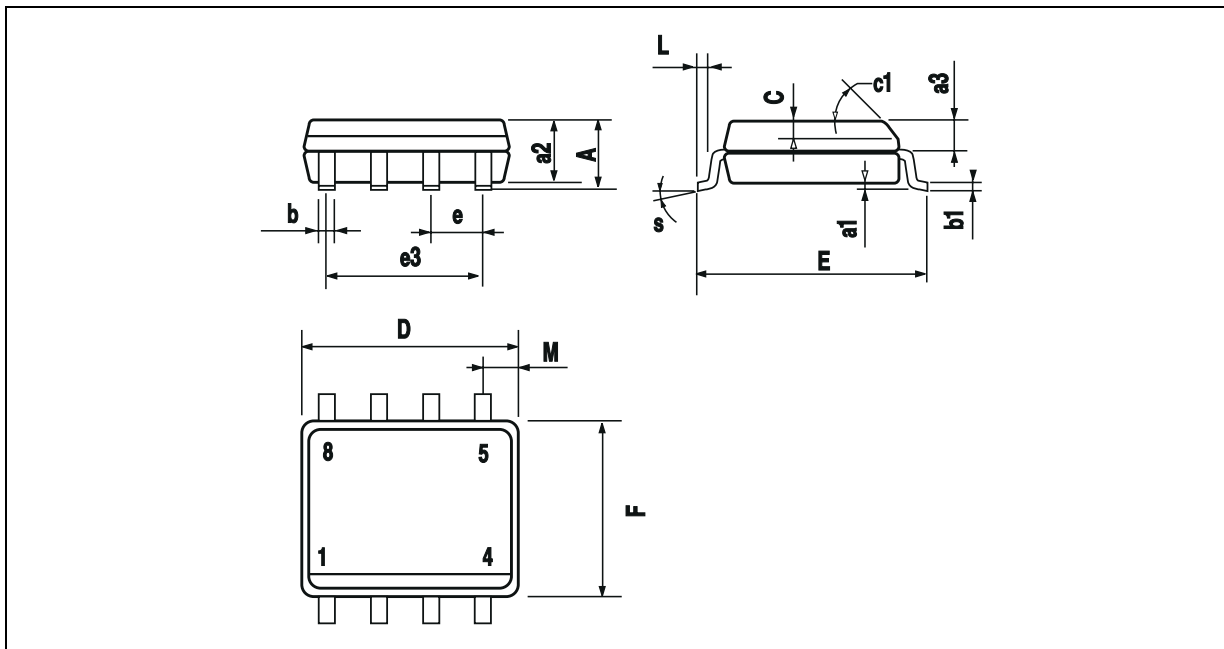

Dim.	Millimeters			Inches		
	Min.	Typ.	Max.	Min.	Typ.	Max.
A			1.75			0.069
a1	0.1		0.25	0.004		0.010
a2			1.65			0.065
a3	0.65		0.85	0.026		0.033
b	0.35		0.48	0.014		0.019
b1	0.19		0.25	0.007		0.010
C	0.25		0.5	0.010		0.020
c1	45° (typ.)					
D	4.8		5.0	0.189		0.197
E	5.8		6.2	0.228		0.244
e		1.27			0.050	
e3		3.81			0.150	
F	3.8		4.0	0.150		0.157
L	0.4		1.27	0.016		0.050
M			0.6			0.024
S	8° (max.)					

Information furnished is believed to be accurate and reliable. However, STMicroelectronics assumes no responsibility for the consequences of use of such information nor for any infringement of patents or other rights of third parties which may result from its use. No license is granted by implication or otherwise under any patent or patent rights of STMicroelectronics. Specifications mentioned in this publication are subject to change without notice. This publication supersedes and replaces all information previously supplied. STMicroelectronics products are not authorized for use as critical components in life support devices or systems without express written approval of STMicroelectronics.

© The ST logo is a registered trademark of STMicroelectronics

© 2000 STMicroelectronics - Printed in Italy - All Rights Reserved
STMicroelectronics GROUP OF COMPANIES

Australia - Brazil - China - Finland - France - Germany - Hong Kong - India - Italy - Japan - Malaysia - Malta - Morocco
Singapore - Spain - Sweden - Switzerland - United Kingdom

© <http://www.st.com>