



# UA748

## PRECISION SINGLE OPERATIONAL AMPLIFIER

- INPUT OFFSET VOLTAGE : 3mV max. OVER TEMPERATURE
- FREQUENCY COMPENSATION WITH A SINGLE 30pF CAPACITOR (C1)
- OPERATION FROM  $\pm 5V$  to  $\pm 15V$
- LOW POWER CONSUMPTION : 50mW AT  $\pm 15V$
- CONTINUOUS SHORT-CIRCUIT PROTECTION
- OPERATION AS A COMPARATOR WITH DIFFERENTIAL INPUTS AS HIGH AS  $\pm 30V$
- NO LATCH-UP WHEN COMMON-MODE RANGE IS EXCEEDED
- SAME PIN CONFIGURATION AS THE LM101A

### DESCRIPTION

The UA748 is a general purpose operational amplifier built on a single silicon chip. The resulting close match and tight thermal coupling gives low offsets and temperature drift as well as fast recovery from thermal transients.

- Short-circuit protection
- Offset voltage null capability
- Large common-mode and differential voltage ranges
- Low power consumption
- No latch-up

The unity-gain compensation specified makes the circuit stable for all feedback configurations, even with capacitive loads. However, it is possible to optimize compensation for best high frequency performance at any gain. The low power dissipation permits high voltage operation and simplifies packaging in full-temperature range systems.

### PIN CONNECTIONS (top view)

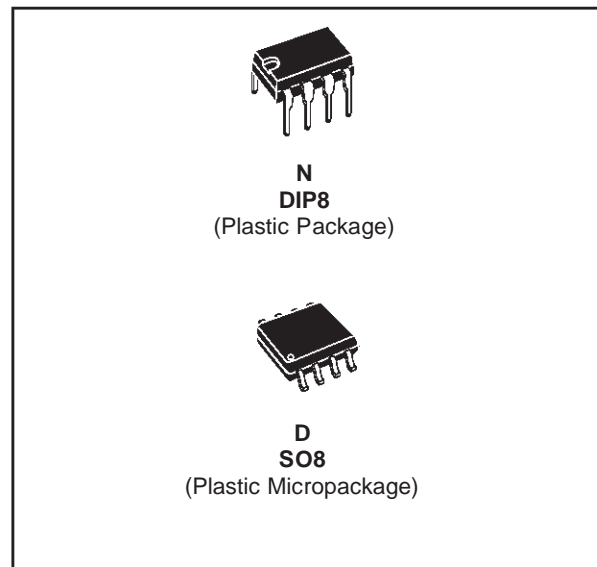
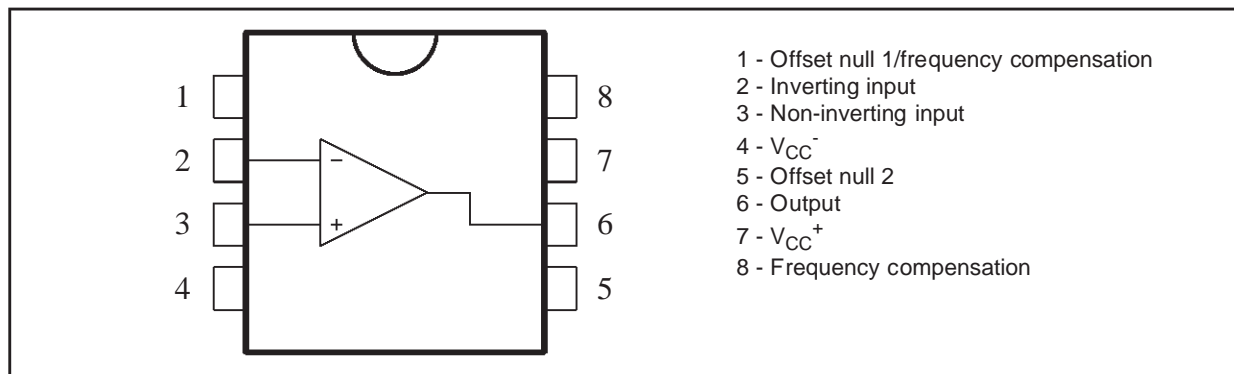

### ORDER CODE

Part Number	Temperature Range	Package	
		N	D
UA748C	0°C, +70°C	•	•
UA748I	-40°C, +105°C	•	•
UA748M	-55°C, +125°C	•	•

**Example : UA748CN**

N = Dual in Line Package (DIP)  
 D = Small Outline Package (SO) - also available in Tape & Reel (DT)

**SCHEMATIC DIAGRAM**

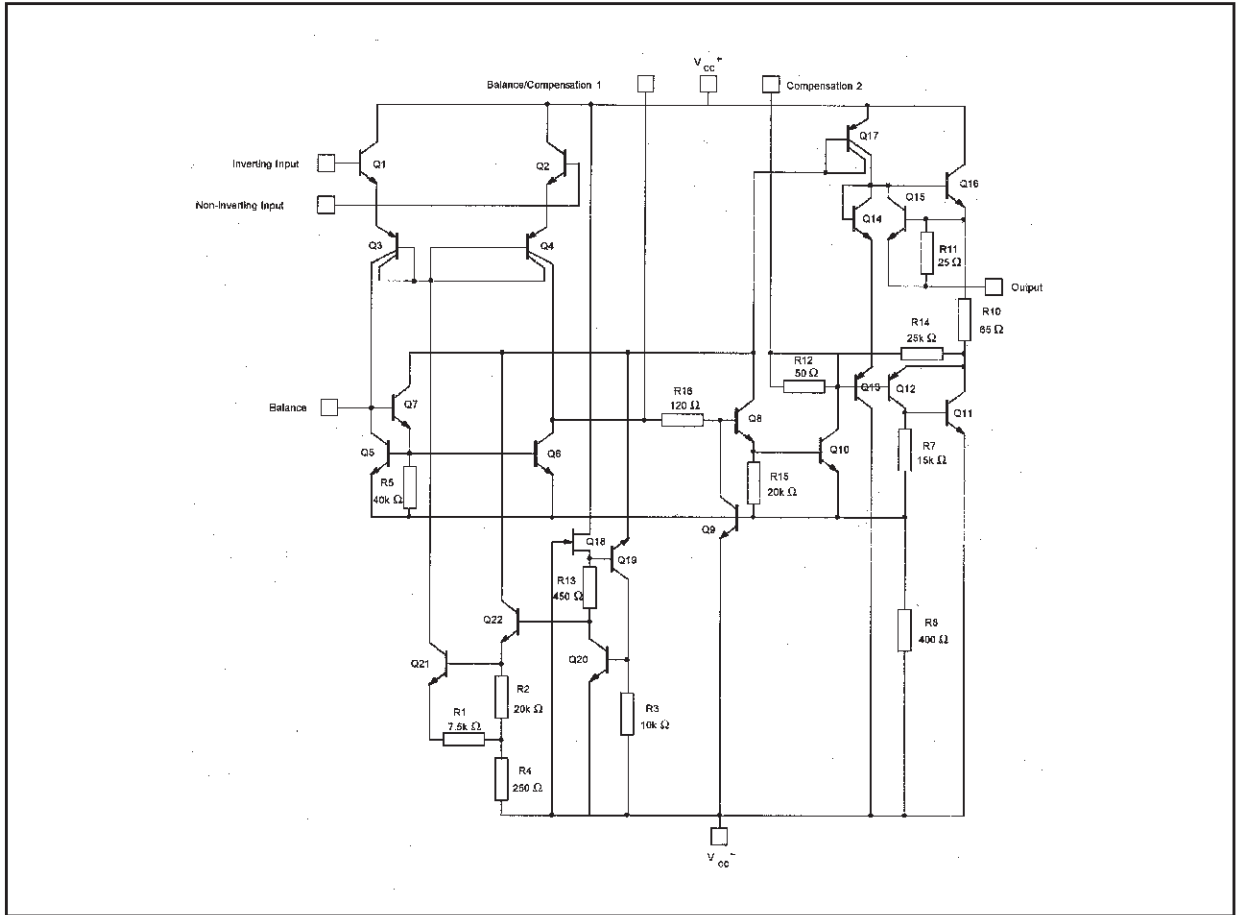

**ABSOLUTE MAXIMUM RATINGS**

Symbol	Parameter	UA748M	UA748I	UA748C	Unit
$V_{CC}$	Supply voltage		±22		V
$V_{id}$	Differential Input Voltage		±30		V
$V_i$	Input Voltage		±15		V
$P_{tot}$	Power Dissipation <sup>1)</sup>		500		mW
	Output Short-circuit Duration		Infinite		
$T_{oper}$	Operating Free-air Temperature Range	-55 to +125	-40 to +105	0 to +70	°C
$T_{stg}$	Storage Temperature Range		-65 to +150		°C

1. Power dissipation must be considered to ensure maximum junction temperature (Tj) is not exceeded.

**ELECTRICAL CHARACTERISTICS**
 $V_{CC} = \pm 15V$ ,  $T_{amb} = +25^{\circ}C$ ,  $C_1 = 30pF$  (unless otherwise specified)

Symbol	Parameter	UA748I/M			UA748C			Unit
		Min.	Typ.	Max.	Min.	Typ.	Max.	
$V_{io}$	Input Offset Voltage ( $R_S \leq 10k\Omega$ ) $T_{amb} = +25^{\circ}C$ $T_{min} \leq T_{amb} \leq T_{max}$		0.7	2 3		2	7.5 10	mV
$I_{io}$	Input Offset Current $T_{amb} = +25^{\circ}C$ $T_{min} \leq T_{amb} \leq T_{max}$		1.5	10 20		2	50 70	nA
$I_{ib}$	Input Bias Current $T_{amb} = +25^{\circ}C$ $T_{min} \leq T_{amb} \leq T_{max}$		25	75 10		70	250 300	nA
$A_{vd}$	Large Signal Voltage Gain ( $V_o = \pm 10V$ , $R_L = 2k\Omega$ ) $T_{amb} = +25^{\circ}C$ $T_{min} \leq T_{amb} \leq T_{max}$	50 25	100		25 15	100		V/mV
SVR	Supply Voltage Rejection Ratio ( $R_S \leq 10k\Omega$ ) $T_{amb} = +25^{\circ}C$ $T_{min} \leq T_{amb} \leq T_{max}$	80 80	96		70 70	96		dB
$I_{CC}$	Supply Current, no load $T_{amb} = +25^{\circ}C$ $T_{min} \leq T_{amb} \leq T_{max}$		1.8	3 3		1.8	3 3	mA
$V_{icm}$	Input Common Mode Voltage Range ( $V_{CC} = \pm 20V$ ) $T_{amb} = +25^{\circ}C$ $T_{min} \leq T_{amb} \leq T_{max}$	$\pm 15$ $\pm 15$			$\pm 15$ $\pm 15$			V
CMR	Common Mode Rejection Ratio ( $R_S \leq 10k\Omega$ ) $T_{amb} = +25^{\circ}C$ $T_{min} \leq T_{amb} \leq T_{max}$	80 80	96		70 70	96		dB
$I_{OS}$	Output short Circuit Current	10	30	50	10	30	50	mA
$\pm V_{opp}$	Output Voltage Swing ( $V_{CC} = \pm 15V$ ) $T_{amb} = +25^{\circ}C$ $T_{min} \leq T_{amb} \leq T_{max}$							V
SR	Slew Rate <sup>1)</sup> $V_i = \pm 10V$ , $R_L = 2k\Omega$ , $C_L = 100pF$ , unity Gain	0.25	0.5		0.25	0.5		V/ $\mu s$
$t_r$	Rise Time $V_i = \pm 20mV$ , $R_L = 2k\Omega$ , $C_L = 100pF$ , unity Gain		0.3			0.3		$\mu s$
$K_{ov}$	Overshoot $V_i = 20mV$ , $R_L = 2k\Omega$ , $C_L = 100pF$ , unity Gain		5			5		%
$Z_i$	Input Impedance ( $V_{CC} = \pm 15V$ )	1.5	4		1.5	4		M $\Omega$
$R_o$	Output Resistance ( $V_{CC} = \pm 15V$ )		75			75		$\Omega$
GBP	Gain Bandwidth Product $V_i = 10mV$ , $R_L = 2k\Omega$ , $C_L = 100pF$ , $f = 100kHz$	0.5	1		0.5	1		MHz
THD	Total Harmonic Distortion $f = 1kHz$ , $A_v = 20dB$ , $R_L = 2k\Omega$ , $V_o = 2V_{pp}$ , $C_L = 100pF$		0.015			0.015		%
$DI_{io}$	Input Offset Current Drift $25^{\circ}C \leq T_{max}$ $T_{min} \leq T_{amb} \leq T_{max}$		10 20	100 200		10 20	300 600	pA/ $^{\circ}C$
$DV_{io}$	Input Offset Voltage Drift $T_{min} \leq T_{amb} \leq T_{max}$		3	15		6	30	$\mu V$ / $^{\circ}C$

1. May be improved up to 10V/ $\mu s$  in inverting amplifier configuration.

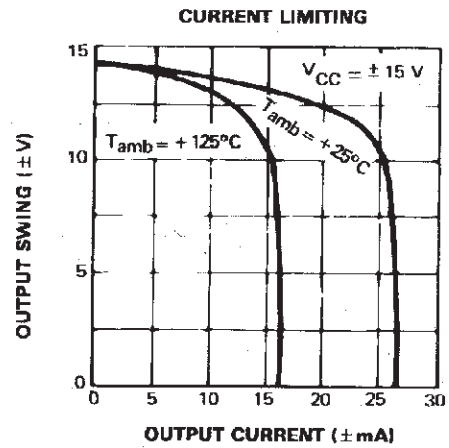
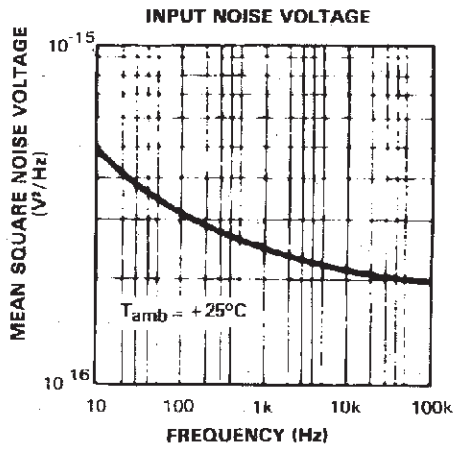
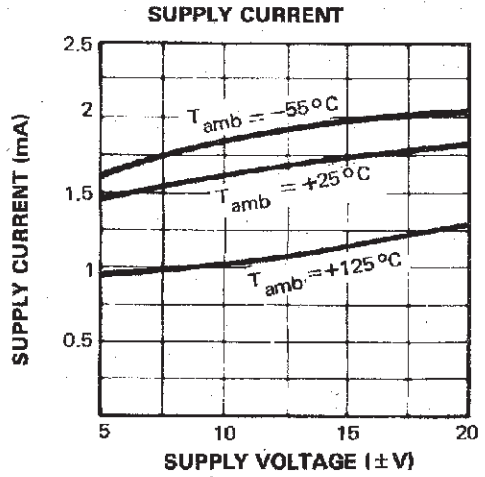
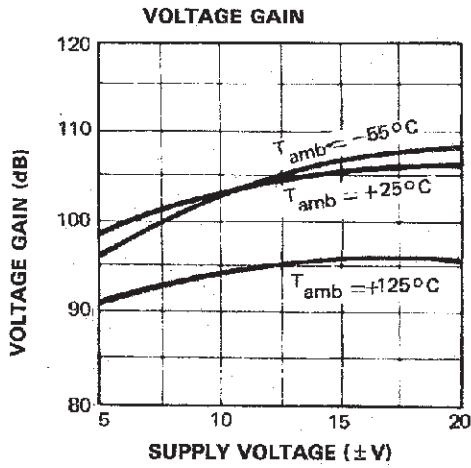

## SINGLE POLE COMPENSATION

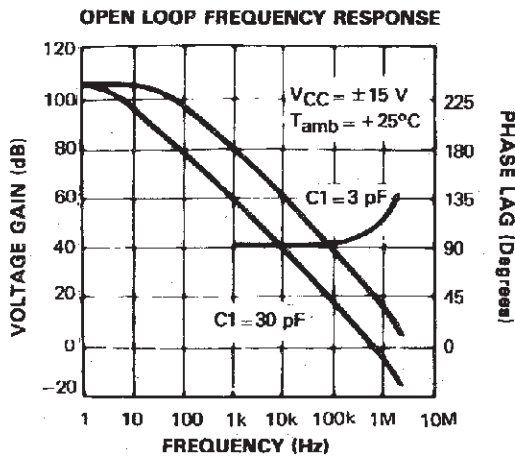

## FEED FORWARD COMPENSATION

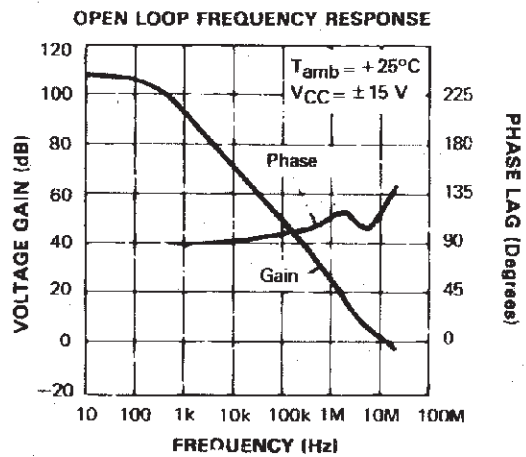

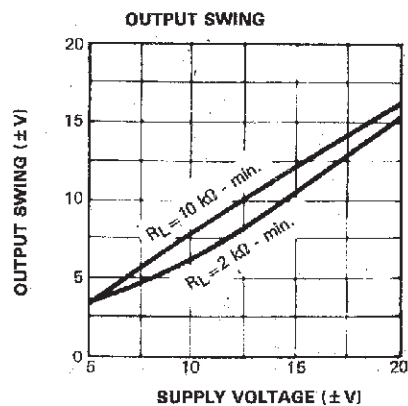
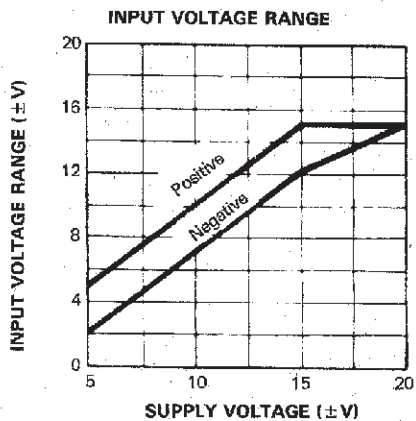

**SINGLE POLE COMPENSATION**

# UA748

## PACKAGE MECHANICAL DATA 8 PINS - PLASTIC DIP

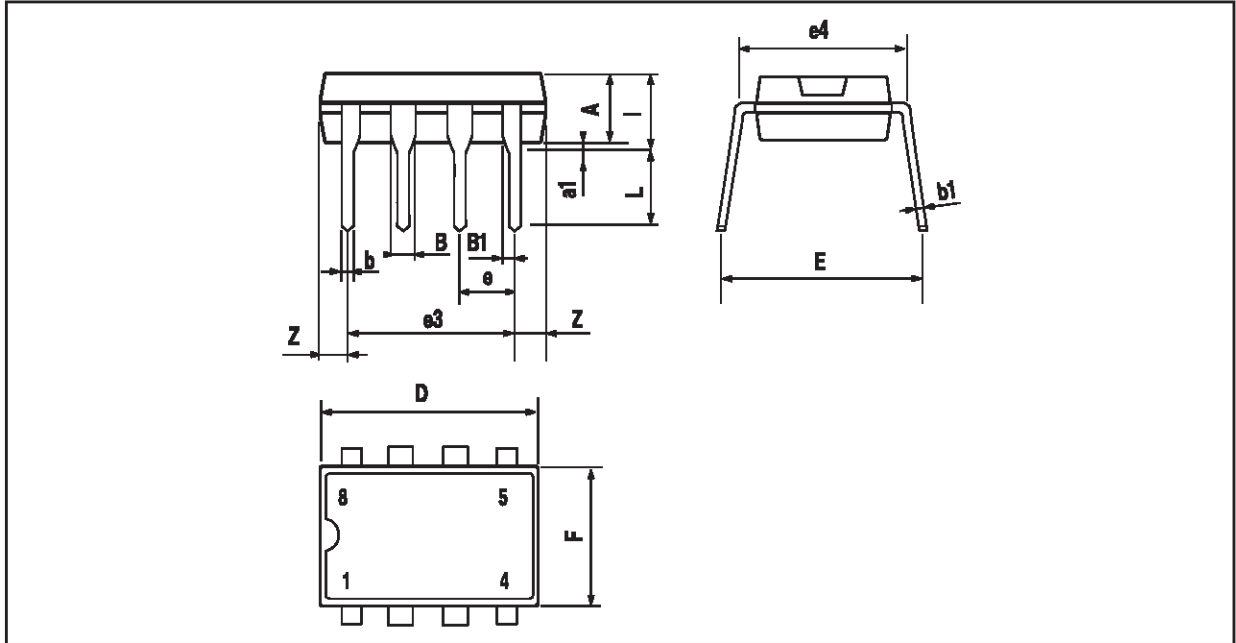

Dim.	Millimeters			Inches		
	Min.	Typ.	Max.	Min.	Typ.	Max.
A		3.32			0.131	
a1	0.51			0.020		
B	1.15		1.65	0.045		0.065
b	0.356		0.55	0.014		0.022
b1	0.204		0.304	0.008		0.012
D			10.92			0.430
E	7.95		9.75	0.313		0.384
e		2.54			0.100	
e3		7.62			0.300	
e4		7.62			0.300	
F			6.6			0.260
i			5.08			0.200
L	3.18		3.81	0.125		0.150
Z			1.52			0.060

**PACKAGE MECHANICAL DATA**  
8 PINS - PLASTIC MICROPACKAGE (SO)

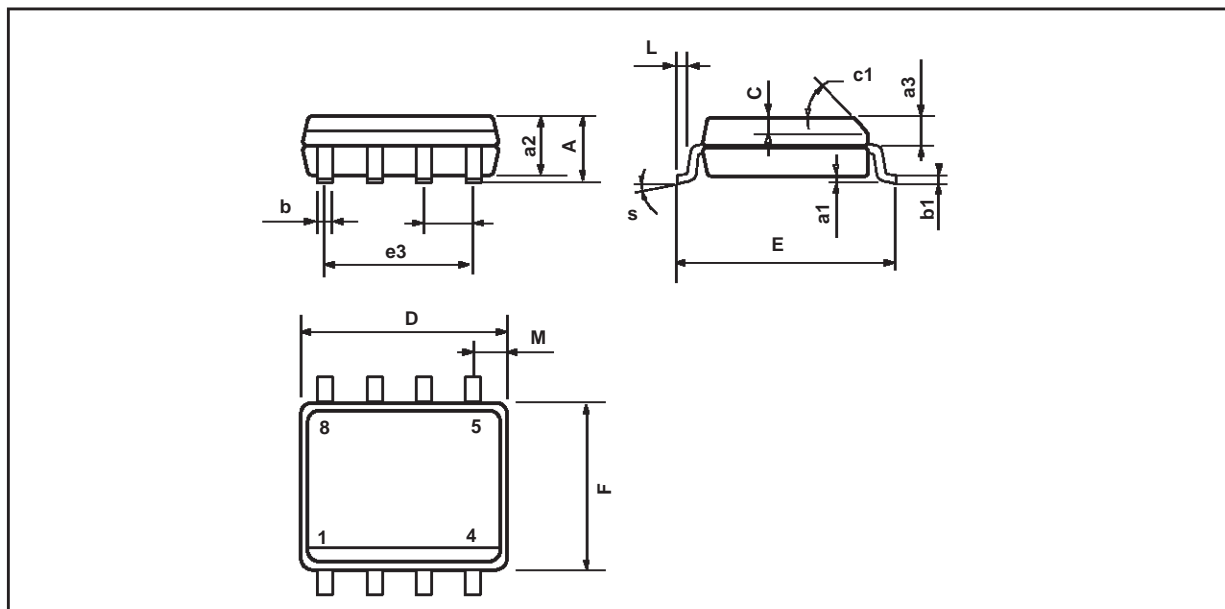

Dim.	Millimeters			Inches		
	Min.	Typ.	Max.	Min.	Typ.	Max.
A			1.75			0.069
a1	0.1		0.25	0.004		0.010
a2			1.65			0.065
a3	0.65		0.85	0.026		0.033
b	0.35		0.48	0.014		0.019
b1	0.19		0.25	0.007		0.010
C	0.25		0.5	0.010		0.020
c1	45° (typ.)					
D	4.8		5.0	0.189		0.197
E	5.8		6.2	0.228		0.244
e		1.27			0.050	
e3		3.81			0.150	
F	3.8		4.0	0.150		0.157
L	0.4		1.27	0.016		0.050
M			0.6			0.024
S	8° (max.)					

Information furnished is believed to be accurate and reliable. However, STMicroelectronics assumes no responsibility for the consequences of use of such information nor for any infringement of patents or other rights of third parties which may result from its use. No license is granted by implication or otherwise under any patent or patent rights of STMicroelectronics. Specifications mentioned in this publication are subject to change without notice. This publication supersedes and replaces all information previously supplied. STMicroelectronics products are not authorized for use as critical components in life support devices or systems without express written approval of STMicroelectronics.

© The ST logo is a registered trademark of STMicroelectronics

© 2001 STMicroelectronics - Printed in Italy - All Rights Reserved  
STMicroelectronics GROUP OF COMPANIES

Australia - Brazil - Canada - China - Finland - France - Germany - Hong Kong - India - Israel - Italy - Japan - Malaysia  
Malta - Morocco - Singapore - Spain - Sweden - Switzerland - United Kingdom - United States

© <http://www.st.com>