

## 128K x 8 Static RAM

### Features

- **High speed**  
—  $t_{AA} = 10 \text{ ns}$
- **CMOS for optimum speed/power**
- **Center power/ground pinout**
- **Automatic power-down when deselected**
- **Easy memory expansion with  $\overline{CE}$  and  $\overline{OE}$  options**
- **Functionally equivalent to CY7C1019V33**

### Functional Description

The CY7C1019BV33 is a high-performance CMOS static RAM organized as 131,072 words by 8 bits. Easy memory expansion is provided by an active LOW Chip Enable ( $\overline{CE}$ ), an active LOW Output Enable ( $\overline{OE}$ ), and three-state drivers. This device has an automatic power-down feature that significantly reduces power consumption when deselected.

Writing to the device is accomplished by taking Chip Enable ( $\overline{CE}$ ) and Write Enable ( $\overline{WE}$ ) inputs LOW. Data on the eight I/O pins ( $I/O_0$  through  $I/O_7$ ) is then written into the location specified on the address pins ( $A_0$  through  $A_{16}$ ).

Reading from the device is accomplished by taking Chip Enable ( $\overline{CE}$ ) and Output Enable ( $\overline{OE}$ ) LOW while forcing Write Enable ( $\overline{WE}$ ) HIGH. Under these conditions, the contents of the memory location specified by the address pins will appear on the I/O pins.

The eight input/output pins ( $I/O_0$  through  $I/O_7$ ) are placed in a high-impedance state when the device is deselected ( $\overline{CE}$  HIGH), the outputs are disabled ( $\overline{OE}$  HIGH), or during a write operation ( $\overline{CE}$  LOW, and  $\overline{WE}$  LOW).

The CY7C1019BV33 is available in a standard 400-mil-wide package.

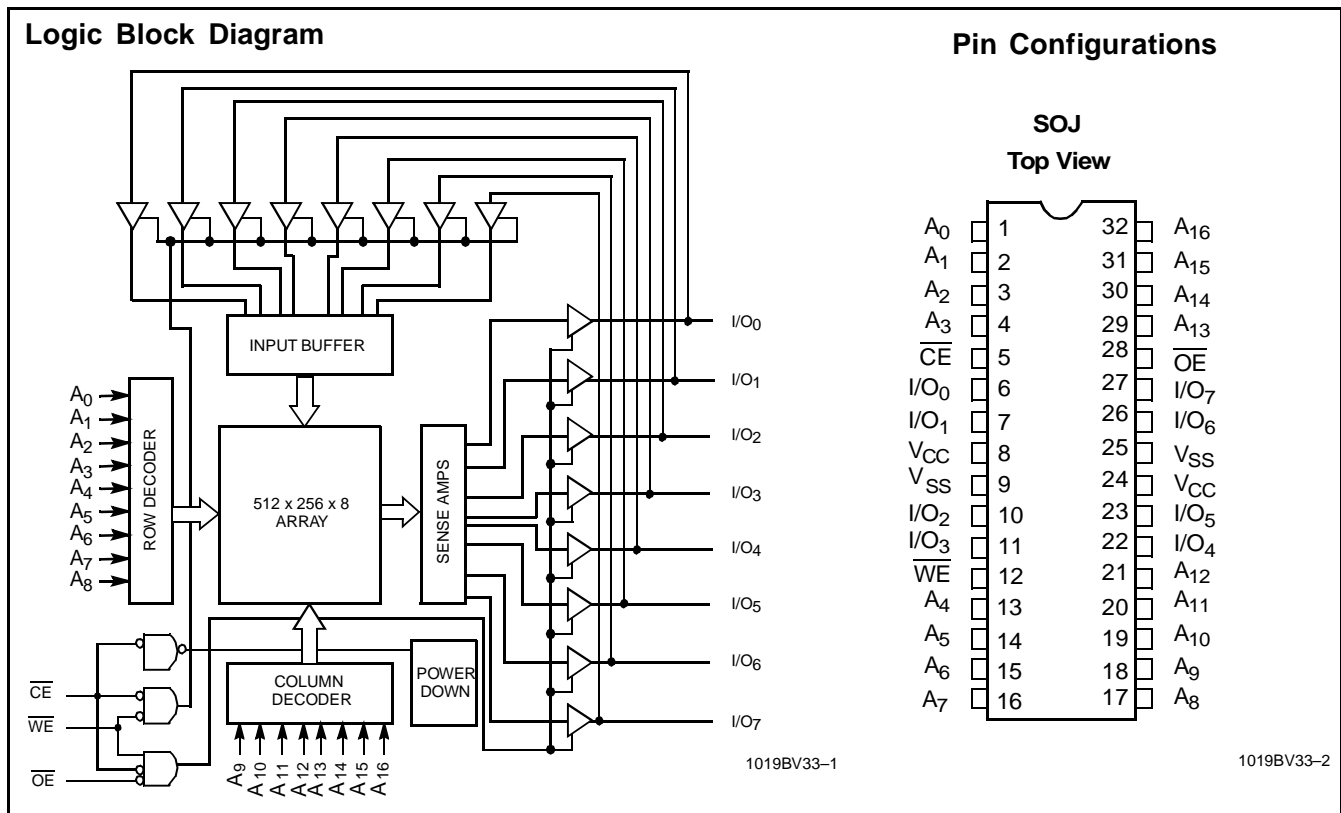

### Selection Guide

	7C1019BV33-10	7C1019BV33-12	7C1019BV33-15
Maximum Access Time (ns)	10	12	15
Maximum Operating Current (mA)	175	160	145
Maximum Standby Current (mA)	5	5	5
L	—	0.5	0.5

### Maximum Ratings

(Above which the useful life may be impaired. For user guidelines, not tested.)

Storage Temperature ..... -65°C to +150°C  
 Ambient Temperature with Power Applied ..... -55°C to +125°C  
 Supply Voltage on V<sub>CC</sub> to Relative GND<sup>[1]</sup> .... -0.5V to +7.0V  
 DC Voltage Applied to Outputs in High Z State<sup>[1]</sup> ..... -0.5V to V<sub>CC</sub> + 0.5V  
 DC Input Voltage<sup>[1]</sup> ..... -0.5V to V<sub>CC</sub> + 0.5V

Current into Outputs (LOW)..... 20 mA  
 Static Discharge Voltage ..... >2001V (per MIL-STD-883, Method 3015)  
 Latch-Up Current..... >200 mA

### Operating Range

Range	Ambient Temperature <sup>[2]</sup>	V <sub>CC</sub>
Commercial	0°C to +70°C	3.3V ± 10%

### Electrical Characteristics Over the Operating Range

Parameter	Description	Test Conditions	7C1019BV33 -10		7C1019BV33 -12		7C1019BV33 -15		Unit
			Min.	Max.	Min.	Max.	Min.	Max.	
V <sub>OH</sub>	Output HIGH Voltage	V <sub>CC</sub> = Min., I <sub>OH</sub> = -4.0 mA	2.4		2.4		2.4		V
V <sub>OL</sub>	Output LOW Voltage	V <sub>CC</sub> = Min., I <sub>OL</sub> = 8.0 mA		0.4		0.4		0.4	V
V <sub>IH</sub>	Input HIGH Voltage		2.2	V <sub>CC</sub> + 0.3	2.2	V <sub>CC</sub> + 0.3	2.2	V <sub>CC</sub> + 0.3	V
V <sub>IL</sub>	Input LOW Voltage <sup>[1]</sup>		-0.3	0.8	-0.3	0.8	-0.3	0.8	V
I <sub>Ix</sub>	Input Load Current	GND ≤ V <sub>I</sub> ≤ V <sub>CC</sub>	-1	+1	-1	+1	-1	+1	μA
I <sub>OZ</sub>	Output Leakage Current	GND ≤ V <sub>I</sub> ≤ V <sub>CC</sub> , Output Disabled	-5	+5	-5	+5	-5	+5	μA
I <sub>CC</sub>	V <sub>CC</sub> Operating Supply Current	V <sub>CC</sub> = Max., I <sub>OUT</sub> = 0 mA, f = f <sub>MAX</sub> = 1/t <sub>RC</sub>		175		160		145	mA
I <sub>SB1</sub>	Automatic CE Power-Down Current —TTL Inputs	Max. V <sub>CC</sub> , CE ≥ V <sub>IH</sub> , V <sub>IN</sub> ≥ V <sub>IH</sub> or V <sub>IN</sub> ≤ V <sub>IL</sub> , f = f <sub>MAX</sub>		20		20		20	mA
I <sub>SB2</sub>	Automatic CE Power-Down Current —CMOS Inputs	Max. V <sub>CC</sub> , CE ≥ V <sub>CC</sub> - 0.3V, V <sub>IN</sub> ≥ V <sub>CC</sub> - 0.3V, or V <sub>IN</sub> ≤ 0.3V, f = 0		5		5		5	mA
			L	-		0.5		0.5	

### Capacitance<sup>[3]</sup>

Parameter	Description	Test Conditions	Max.	Unit
C <sub>IN</sub>	Input Capacitance	T <sub>A</sub> = 25°C, f = 1 MHz, V <sub>CC</sub> = 5.0V	6	pF
C <sub>OUT</sub>	Output Capacitance		8	pF

#### Notes:

- V<sub>IL</sub> (min.) = -2.0V for pulse durations of less than 20 ns.
- T<sub>A</sub> is the "Instant On" case temperature.
- Tested initially and after any design or process changes that may affect these parameters.

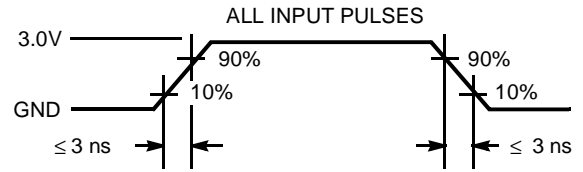
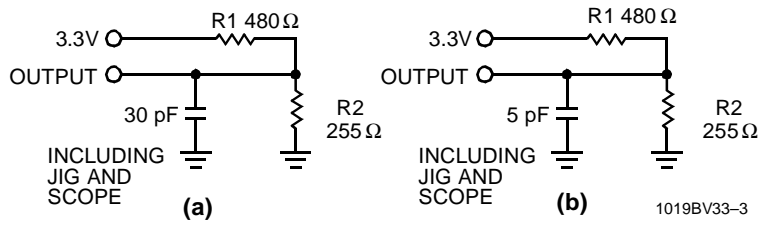
**AC Test Loads and Waveforms**

1019BV33-3

1019BV33-4

Equivalent to: THÉVENIN EQUIVALENT  
 OUTPUT  $\text{---} \frac{167\Omega}{\text{---}} \text{---} 1.73\text{V}$

**Switching Characteristics<sup>[4]</sup> Over the Operating Range**

Parameter	Description	7C1019BV33-10		7C1019BV33-12		7C1019BV33-15		Unit
		Min.	Max.	Min.	Max.	Min.	Max.	
<b>READ CYCLE</b>								
$t_{RC}$	Read Cycle Time	10		12		15		ns
$t_{AA}$	Address to Data Valid		10		12		15	ns
$t_{OHA}$	Data Hold from Address Change	3		3		3		ns
$t_{ACE}$	$\overline{CE}$ LOW to Data Valid		10		12		15	ns
$t_{DOE}$	$\overline{OE}$ LOW to Data Valid		5		6		7	ns
$t_{LZOE}$	$\overline{OE}$ LOW to Low Z	0		0		0		ns
$t_{HZOE}$	$\overline{OE}$ HIGH to High Z <sup>[5, 6]</sup>		5		6		7	ns
$t_{LZCE}$	$\overline{CE}$ LOW to Low Z <sup>[6]</sup>	3		3		3		ns
$t_{HZCE}$	$\overline{CE}$ HIGH to High Z <sup>[5, 6]</sup>		5		6		7	ns
$t_{PU}$	$\overline{CE}$ LOW to Power-Up	0		0		0		ns
$t_{PD}$	$\overline{CE}$ HIGH to Power-Down		10		12		15	ns
<b>WRITE CYCLE<sup>[7, 8]</sup></b>								
$t_{WC}$	Write Cycle Time	10		12		15		ns
$t_{SCE}$	$\overline{CE}$ LOW to Write End	8		9		10		ns
$t_{AW}$	Address Set-Up to Write End	7		8		10		ns
$t_{HA}$	Address Hold from Write End	0		0		0		ns
$t_{SA}$	Address Set-Up to Write Start	0		0		0		ns
$t_{PWE}$	$\overline{WE}$ Pulse Width	7		8		10		ns
$t_{SD}$	Data Set-Up to Write End	5		6		8		ns
$t_{HD}$	Data Hold from Write End	0		0		0		ns
$t_{LZWE}$	$\overline{WE}$ HIGH to Low Z <sup>[6]</sup>	3		3		3		ns
$t_{HZWE}$	$\overline{WE}$ LOW to High Z <sup>[5, 6]</sup>		5		6		7	ns

**Notes:**

- Test conditions assume signal transition time of 3 ns or less, timing reference levels of 1.5V, input pulse levels of 0 to 3.0V, and output loading of the specified  $I_{OL}/I_{OH}$  and 30-pF load capacitance.
- $t_{HZOE}$ ,  $t_{HZCE}$ , and  $t_{HZWE}$  are specified with a load capacitance of 5 pF as in part (b) of AC Test Loads. Transition is measured  $\pm 500$  mV from steady-state voltage.
- At any given temperature and voltage condition,  $t_{HZCE}$  is less than  $t_{LZCE}$ ,  $t_{HZOE}$  is less than  $t_{LZOE}$ , and  $t_{HZWE}$  is less than  $t_{LZWE}$  for any given device.
- The internal write time of the memory is defined by the overlap of  $\overline{CE}$  LOW and  $\overline{WE}$  LOW.  $\overline{CE}$  and  $\overline{WE}$  must be LOW to initiate a write, and the transition of any of these signals can terminate the write. The input data set-up and hold timing should be referenced to the leading edge of the signal that terminates the write.
- The minimum write cycle time for Write Cycle no. 3 ( $\overline{WE}$  controlled,  $\overline{OE}$  LOW) is the sum of  $t_{HZWE}$  and  $t_{SD}$ .

**Data Retention Characteristics** Over the Operating Range (L Version Only)

Parameter	Description	Conditions	Min.	Max.	Unit
$V_{DR}$	$V_{CC}$ for Data Retention	No input may exceed $V_{CC} + 0.5V$	2.0		V
$I_{CCDR}$	Data Retention Current	$V_{CC} = V_{DR} = 2.0V$ , $CE \geq V_{CC} - 0.3V$ ,		150	$\mu A$
$t_{CDR}^{[3]}$	Chip Deselect to Data Retention Time	$V_{IN} \geq V_{CC} - 0.3V$ or $V_{IN} \leq 0.3V$	0		ns
$t_R$	Operation Recovery Time		200		$\mu s$

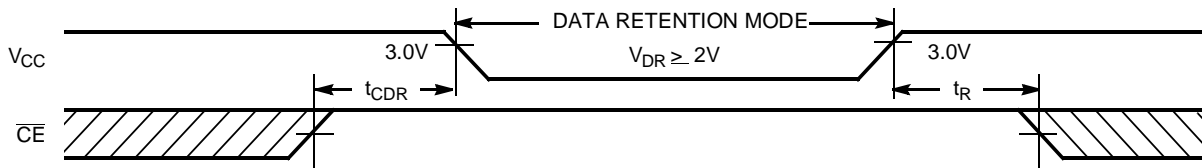
**Data Retention Waveform**

1019BV33-5

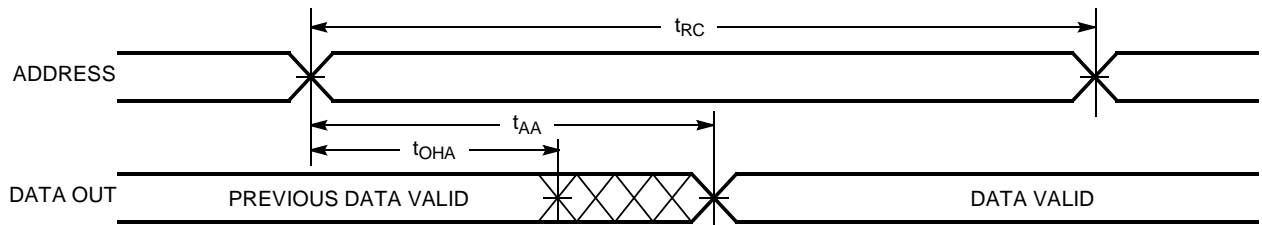
**Switching Waveforms**
**Read Cycle No. 1<sup>[9, 10]</sup>**

1019BV33-6

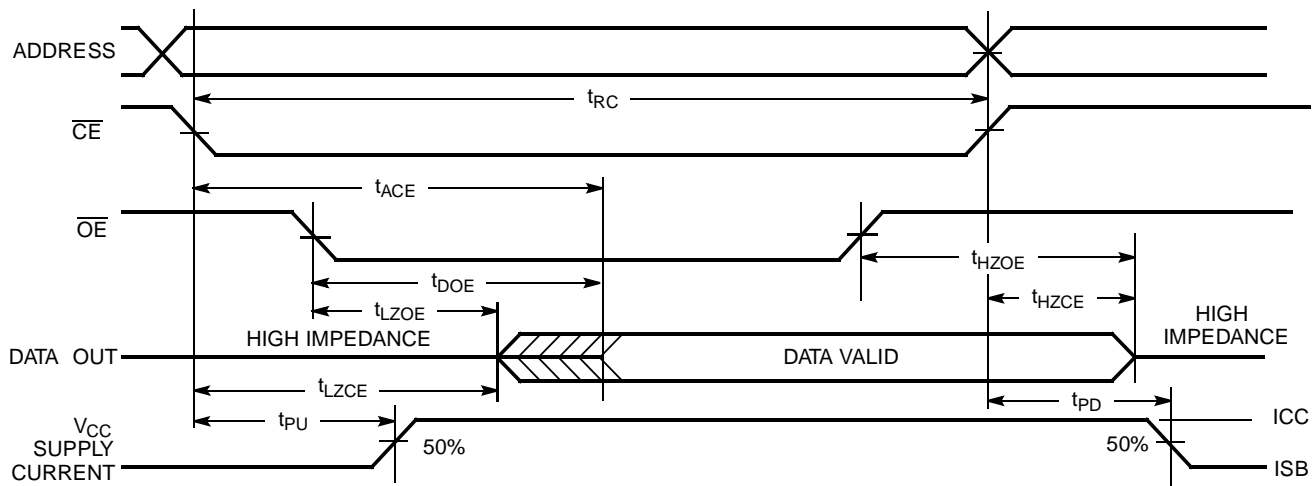
**Read Cycle No. 2 ( $\overline{OE}$  Controlled)<sup>[10, 11]</sup>**

1019BV33-7

**Notes:**

9. Device is continuously selected.  $\overline{OE}, \overline{CE} = V_{IL}$ .
10.  $\overline{WE}$  is HIGH for read cycle.
11. Address valid prior to or coincident with  $\overline{CE}$  transition LOW.

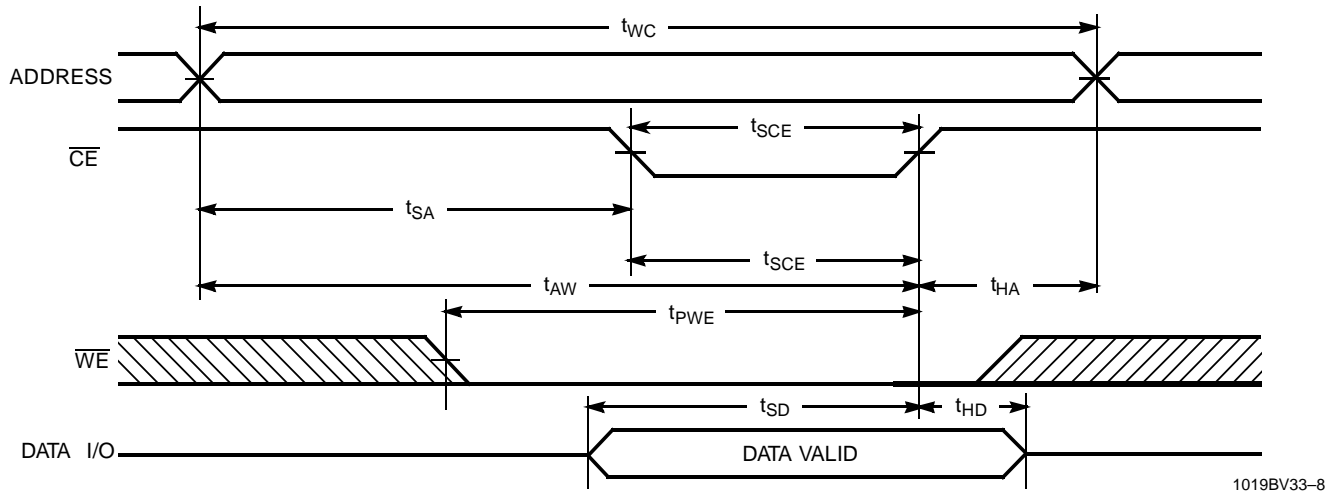
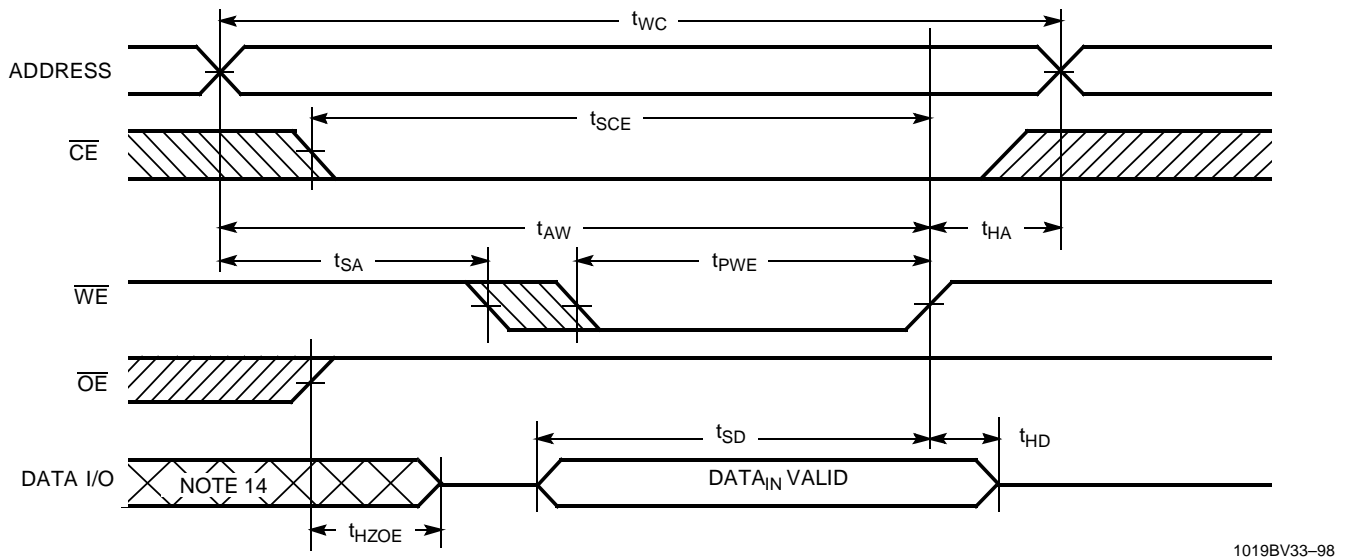
**Switching Waveforms (continued)**
**Write Cycle No. 1 ( $\overline{CE}$  Controlled)<sup>[12, 13]</sup>**

**Write Cycle No. 2 ( $\overline{WE}$  Controlled,  $\overline{OE}$  HIGH During Write)<sup>[12, 13]</sup>**

**Notes:**

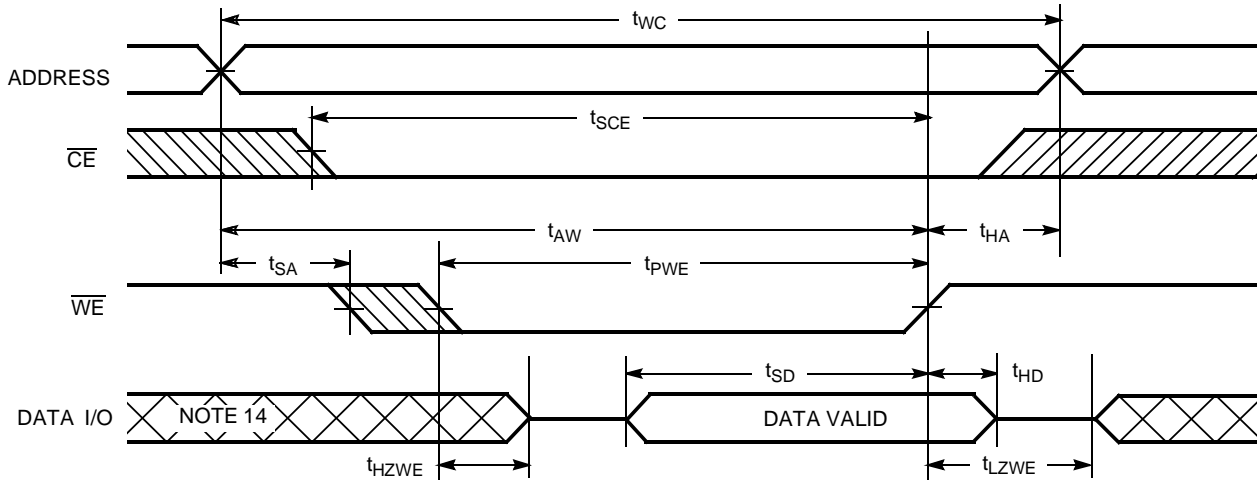
12. Data I/O is high impedance if  $\overline{OE} = V_{IH}$ .
13. If  $\overline{CE}$  goes HIGH simultaneously with  $\overline{WE}$  going HIGH, the output remains in a high-impedance state.
14. During this period the I/Os are in the output state and input signals should not be applied.

**Switching Waveforms** (continued)

**Write Cycle No. 3 ( $\overline{WE}$  Controlled,  $\overline{OE}$  LOW)<sup>[13]</sup>**

1019BV33-10

**Truth Table**

$\overline{CE}$	$\overline{OE}$	$\overline{WE}$	I/O <sub>0</sub> -I/O <sub>7</sub>	Mode	Power
H	X	X	High Z	Power-Down	Standby ( $I_{SB}$ )
X	X	X	High Z	Power-Down	Standby ( $I_{SB}$ )
L	L	H	Data Out	Read	Active ( $I_{CC}$ )
L	X	L	Data In	Write	Active ( $I_{CC}$ )
L	H	H	High Z	Selected, Outputs Disabled	Active ( $I_{CC}$ )

**Ordering Information**

Speed (ns)	Ordering Code	Package Name	Package Type	Operating Range
10	CY7C1019BV33-10VC	V33	32-Lead 400-Mil Molded SOJ	Commercial
12	CY7C1019BV33-12VC	V33	32-Lead 400-Mil Molded SOJ	
	CY7C1019BV33L-12VC	V33	32-Lead 400-Mil Molded SOJ	
15	CY7C1019BV33-15VC	V33	32-Lead 400-Mil Molded SOJ	
	CY7C1019BV33L-15VC	V33	32-Lead 400-Mil Molded SOJ	
	CY7C1019BV33-15VI	V33	32-Lead 400-Mil Molded SOJ	Industrial

Document #: 38-01053-\*A

Package Diagram

32-Lead (400-Mil) Molded SOJ V33

DIMENSIONS IN INCHES  
MIN.  
MAX.

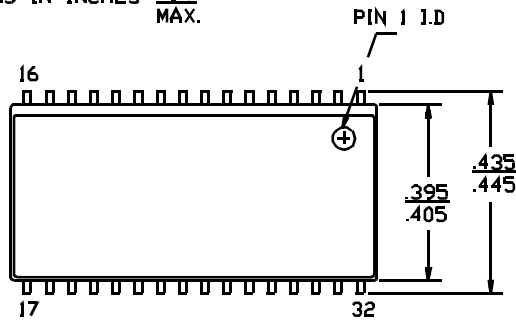

DETAIL A  
EXTERNAL LEAD DESIGN

