



**PRELIMINARY**

**CY7C1411V18**  
**CY7C1426V18**  
**CY7C1413V18**  
**CY7C1415V18**

---

---

## 36-Mbit QDR™-II SRAM 4-Word Burst Architecture

### Features

- **Separate Independent Read and Write data ports**  
— Supports concurrent transactions
- **250-MHz clock for high bandwidth**
- **4-Word Burst for reducing address bus frequency**
- **Double Data Rate (DDR) interfaces on both Read and Write ports (data transferred at 500 MHz) at 250 MHz**
- **Two input clocks (K and  $\bar{K}$ ) for precise DDR timing**  
— SRAM uses rising edges only
- **Two output clocks (C and  $\bar{C}$ ) account for clock skew and flight time mismatching**
- **Echo clocks (CQ and  $\bar{CQ}$ ) simplify data capture in high-speed systems**
- **Single multiplexed address input bus latches address inputs for both Read and Write ports**
- **Separate Port Selects for depth expansion**
- **Synchronous internally self-timed writes**
- **Available in x8, x9, x18, and x36 configurations**
- **Full data coherency providing most current data**
- **Core  $V_{DD} = 1.8(+/-0.1V)$ ; I/O  $V_{DDQ} = 1.4V$  to  $V_{DD}$**
- **15 x 17 x 1.4 mm 1.0-mm pitch FBGA package, 165-ball (11 x 15 matrix)**
- **Variable drive HSTL output buffers**
- **JTAG 1149.1 compatible test access port**
- **Delay Lock Loop (DLL) for accurate data placement**

### Configurations

CY7C1411V18—4M x 8  
CY7C1426V18—4M x 9  
CY7C1413V18—2M x 18  
CY7C1415V18—1M x 36

### Functional Description

The CY7C1411V18, CY7C1426V18, CY7C1413V18, and CY7C1415V18 are 1.8V Synchronous Pipelined SRAMs, equipped with QDR™-II architecture. QDR-II architecture consists of two separate ports to access the memory array. The Read port has dedicated Data Outputs to support Read operations and the Write port has dedicated Data Inputs to support Write operations. QDR-II architecture has separate data inputs and data outputs to completely eliminate the need to “turn-around” the data bus required with common I/O devices. Access to each port is accomplished through a common address bus. Addresses for Read and Write addresses are latched on alternate rising edges of the input (K) clock. Accesses to the QDR-II Read and Write ports are completely independent of one another. In order to maximize data throughput, both Read and Write ports are equipped with Double Data Rate (DDR) interfaces. Each address location is associated with four 8-bit words (CY7C1411V18) or 9-bit words (CY7C1426V18) or 18-bit words (CY7C1413V18) or 36-bit words (CY7C1415V18) that burst sequentially into or out of the device. Since data can be transferred into and out of the device on every rising edge of both input clocks (K and  $\bar{K}$  and C and  $\bar{C}$ ), memory bandwidth is maximized while simplifying system design by eliminating bus “turn-arounds”.

Depth expansion is accomplished with Port Selects for each port. Port selects allow each port to operate independently.

All synchronous inputs pass through input registers controlled by the K or  $\bar{K}$  input clocks. All data outputs pass through output registers controlled by the C or  $\bar{C}$  input clocks. Writes are conducted with on-chip synchronous self-timed write circuitry.



PRELIMINARY

CY7C1411V18  
CY7C1426V18  
CY7C1413V18  
CY7C1415V18

Logic Block Diagram (CY7C1411V18)

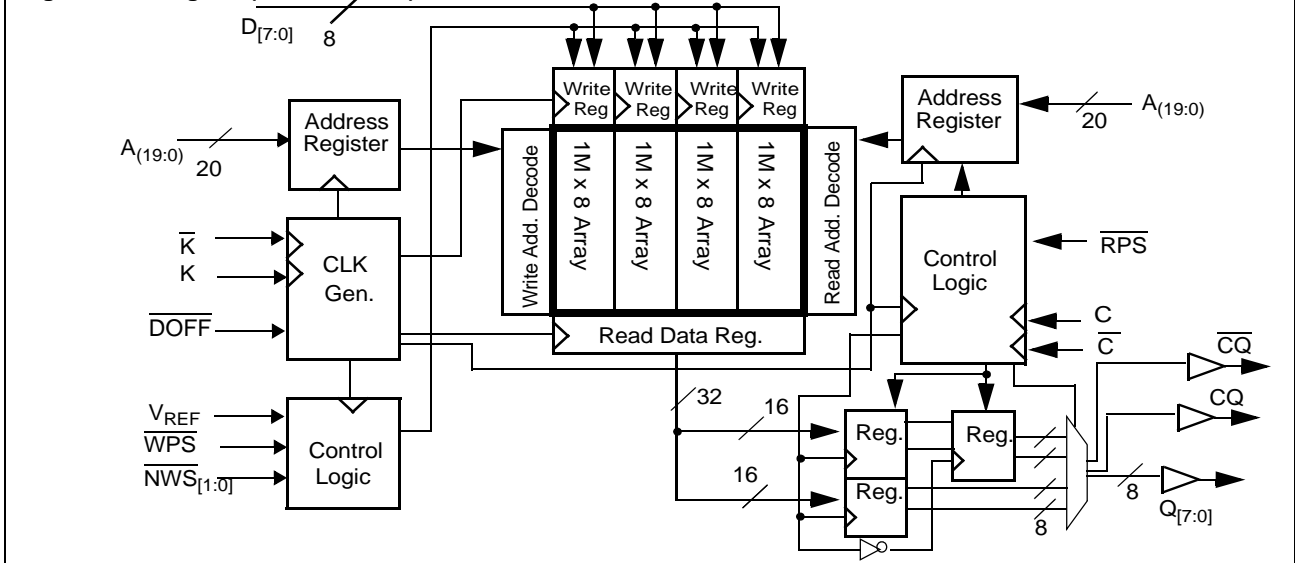

Logic Block Diagram (CY7C1426V18)

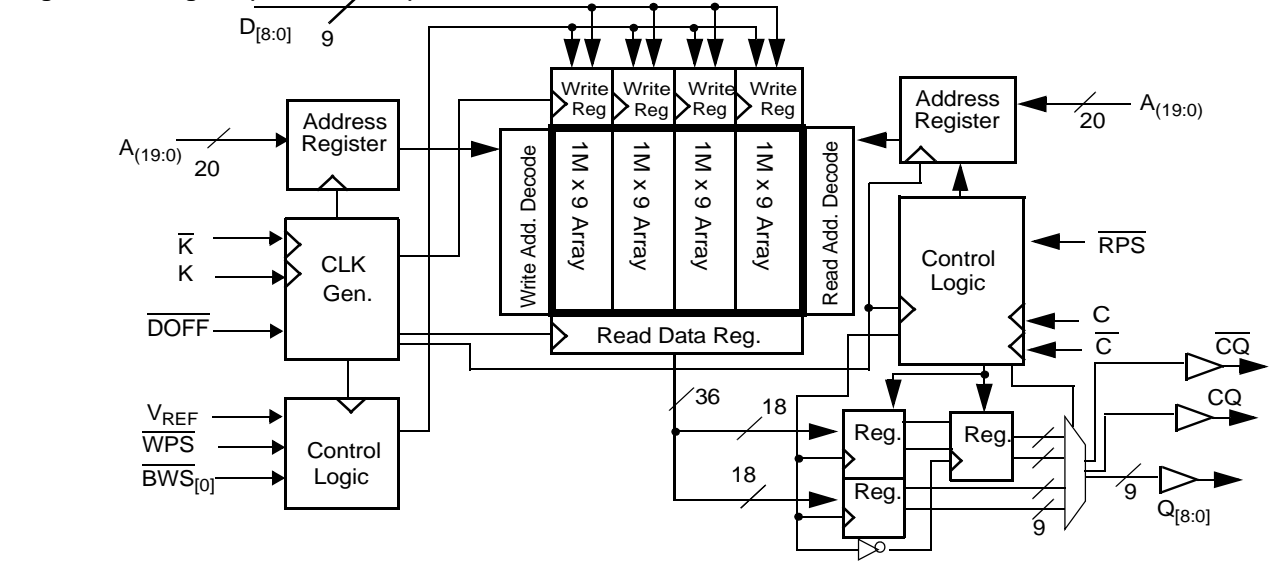

**Logic Block Diagram (CY7C1413V18)**

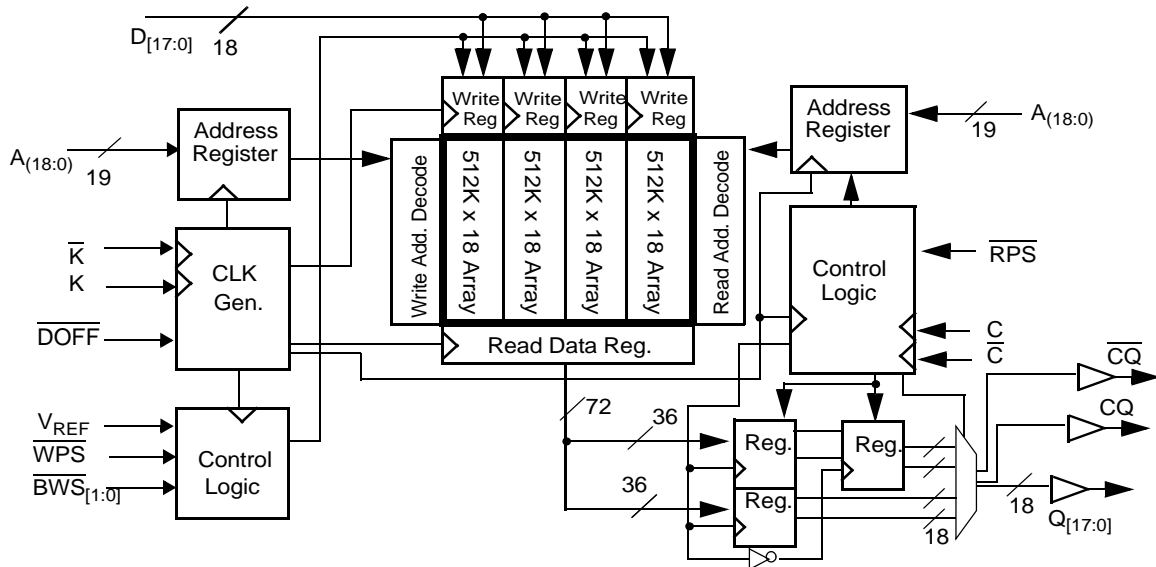

**Logic Block Diagram (CY7C1415V18)**

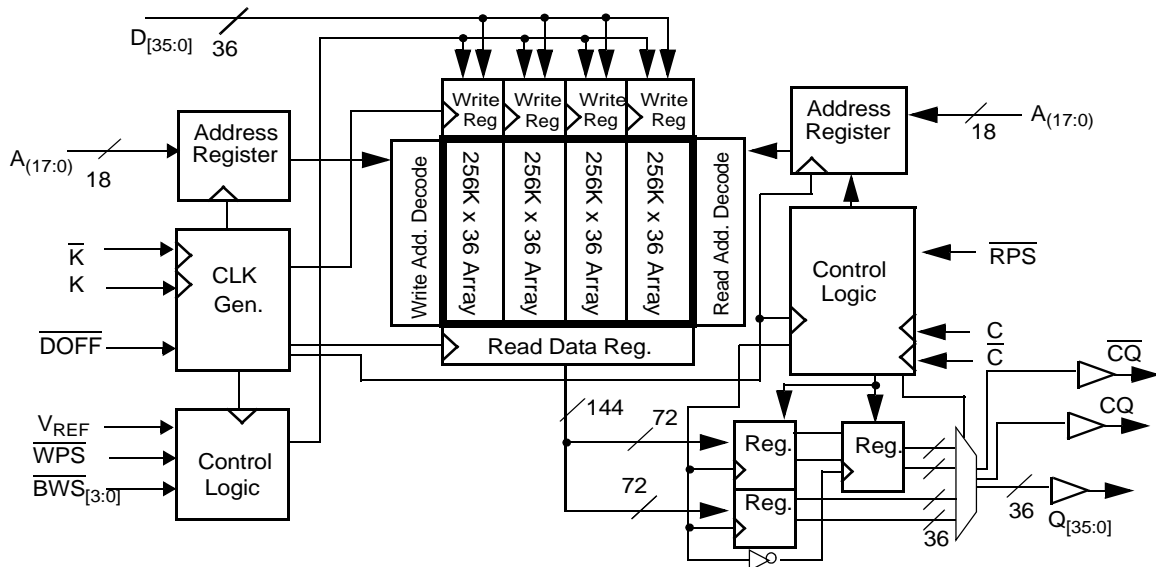

**Selection Guide**

	<b>250 MHz</b>	<b>200 MHz</b>	<b>167 MHz</b>	<b>Unit</b>
Maximum Operating Frequency	250	200	167	MHz
Maximum Operating Current	TBD	TBD	TBD	mA



**PRELIMINARY**

**CY7C1411V18  
CY7C1426V18  
CY7C1413V18  
CY7C1415V18**

**Pin Configurations**

**CY7C1411V18 (4M x 8)–15 x 17 FBGA**

	1	2	3	4	5	6	7	8	9	10	11
<b>A</b>	$\overline{\text{CQ}}$	NC/72M	A	$\overline{\text{WPS}}$	$\overline{\text{NWS}}_1$	$\overline{\text{K}}$	NC/144M	$\overline{\text{RPS}}$	A	A	CQ
<b>B</b>	NC	NC	NC	A	NC/288M	K	$\overline{\text{NWS}}_0$	A	NC	NC	Q3
<b>C</b>	NC	NC	NC	$V_{SS}$	A	NC	A	$V_{SS}$	NC	NC	D3
<b>D</b>	NC	D4	NC	$V_{SS}$	$V_{SS}$	$V_{SS}$	$V_{SS}$	$V_{SS}$	NC	NC	NC
<b>E</b>	NC	NC	Q4	$V_{DDQ}$	$V_{SS}$	$V_{SS}$	$V_{SS}$	$V_{DDQ}$	NC	D2	Q2
<b>F</b>	NC	NC	NC	$V_{DDQ}$	$V_{DD}$	$V_{SS}$	$V_{DD}$	$V_{DDQ}$	NC	NC	NC
<b>G</b>	NC	D5	Q5	$V_{DDQ}$	$V_{DD}$	$V_{SS}$	$V_{DD}$	$V_{DDQ}$	NC	NC	NC
<b>H</b>	$\overline{\text{DOFF}}$	$V_{REF}$	$V_{DDQ}$	$V_{DDQ}$	$V_{DD}$	$V_{SS}$	$V_{DD}$	$V_{DDQ}$	$V_{DDQ}$	$V_{REF}$	ZQ
<b>J</b>	NC	NC	NC	$V_{DDQ}$	$V_{DD}$	$V_{SS}$	$V_{DD}$	$V_{DDQ}$	NC	Q1	D1
<b>K</b>	NC	NC	NC	$V_{DDQ}$	$V_{DD}$	$V_{SS}$	$V_{DD}$	$V_{DDQ}$	NC	NC	NC
<b>L</b>	NC	Q6	D6	$V_{DDQ}$	$V_{SS}$	$V_{SS}$	$V_{SS}$	$V_{DDQ}$	NC	NC	Q0
<b>M</b>	NC	NC	NC	$V_{SS}$	$V_{SS}$	$V_{SS}$	$V_{SS}$	$V_{SS}$	NC	NC	D0
<b>N</b>	NC	D7	NC	$V_{SS}$	A	A	A	$V_{SS}$	NC	NC	NC
<b>P</b>	NC	NC	Q7	A	A	C	A	A	NC	NC	NC
<b>R</b>	TDO	TCK	A	A	A	$\overline{\text{C}}$	A	A	A	TMS	TDI

**CY7C1426V18 (4M x 9)–15 x 17 FBGA**

	1	2	3	4	5	6	7	8	9	10	11
<b>A</b>	$\overline{\text{CQ}}$	NC/72M	A	$\overline{\text{WPS}}$	NC	$\overline{\text{K}}$	NC/144M	$\overline{\text{RPS}}$	A	A	CQ
<b>B</b>	NC	NC	NC	A	NC/288M	K	$\overline{\text{BWS}}_0$	A	NC	NC	Q4
<b>C</b>	NC	NC	NC	$V_{SS}$	A	NC	A	$V_{SS}$	NC	NC	D4
<b>D</b>	NC	D5	NC	$V_{SS}$	$V_{SS}$	$V_{SS}$	$V_{SS}$	$V_{SS}$	NC	NC	NC
<b>E</b>	NC	NC	Q5	$V_{DDQ}$	$V_{SS}$	$V_{SS}$	$V_{SS}$	$V_{DDQ}$	NC	D3	Q3
<b>F</b>	NC	NC	NC	$V_{DDQ}$	$V_{DD}$	$V_{SS}$	$V_{DD}$	$V_{DDQ}$	NC	NC	NC
<b>G</b>	NC	D6	Q6	$V_{DDQ}$	$V_{DD}$	$V_{SS}$	$V_{DD}$	$V_{DDQ}$	NC	NC	NC
<b>H</b>	$\overline{\text{DOFF}}$	$V_{REF}$	$V_{DDQ}$	$V_{DDQ}$	$V_{DD}$	$V_{SS}$	$V_{DD}$	$V_{DDQ}$	$V_{DDQ}$	$V_{REF}$	ZQ
<b>J</b>	NC	NC	NC	$V_{DDQ}$	$V_{DD}$	$V_{SS}$	$V_{DD}$	$V_{DDQ}$	NC	Q2	D2
<b>K</b>	NC	NC	NC	$V_{DDQ}$	$V_{DD}$	$V_{SS}$	$V_{DD}$	$V_{DDQ}$	NC	NC	NC
<b>L</b>	NC	Q7	D7	$V_{DDQ}$	$V_{SS}$	$V_{SS}$	$V_{SS}$	$V_{DDQ}$	NC	NC	Q1
<b>M</b>	NC	NC	NC	$V_{SS}$	$V_{SS}$	$V_{SS}$	$V_{SS}$	$V_{SS}$	NC	NC	D1
<b>N</b>	NC	D8	NC	$V_{SS}$	A	A	A	$V_{SS}$	NC	NC	NC
<b>P</b>	NC	NC	Q8	A	A	C	A	A	NC	D0	Q0
<b>R</b>	TDO	TCK	A	A	A	$\overline{\text{C}}$	A	A	A	TMS	TDI



**PRELIMINARY**

**CY7C1411V18  
CY7C1426V18  
CY7C1413V18  
CY7C1415V18**

**Pin Configurations** (continued)

**CY7C1413V18 (2M x 18)–15 x 17 FBGA**

	1	2	3	4	5	6	7	8	9	10	11
<b>A</b>	$\overline{\text{CQ}}$	NC/144M	A	$\overline{\text{WPS}}$	$\overline{\text{BWS}}_1$	$\overline{\text{K}}$	NC/288M	$\overline{\text{RPS}}$	A	NC/72M	CQ
<b>B</b>	NC	Q9	D9	A	NC	K	$\overline{\text{BWS}}_0$	A	NC	NC	Q8
<b>C</b>	NC	NC	D10	$V_{SS}$	A	NC	A	$V_{SS}$	NC	Q7	D8
<b>D</b>	NC	D11	Q10	$V_{SS}$	$V_{SS}$	$V_{SS}$	$V_{SS}$	$V_{SS}$	NC	NC	D7
<b>E</b>	NC	NC	Q11	$V_{DDQ}$	$V_{SS}$	$V_{SS}$	$V_{SS}$	$V_{DDQ}$	NC	D6	Q6
<b>F</b>	NC	Q12	D12	$V_{DDQ}$	$V_{DD}$	$V_{SS}$	$V_{DD}$	$V_{DDQ}$	NC	NC	Q5
<b>G</b>	NC	D13	Q13	$V_{DDQ}$	$V_{DD}$	$V_{SS}$	$V_{DD}$	$V_{DDQ}$	NC	NC	D5
<b>H</b>	$\overline{\text{DOFF}}$	$V_{REF}$	$V_{DDQ}$	$V_{DDQ}$	$V_{DD}$	$V_{SS}$	$V_{DD}$	$V_{DDQ}$	$V_{DDQ}$	$V_{REF}$	ZQ
<b>J</b>	NC	NC	D14	$V_{DDQ}$	$V_{DD}$	$V_{SS}$	$V_{DD}$	$V_{DDQ}$	NC	Q4	D4
<b>K</b>	NC	NC	Q14	$V_{DDQ}$	$V_{DD}$	$V_{SS}$	$V_{DD}$	$V_{DDQ}$	NC	D3	Q3
<b>L</b>	NC	Q15	D15	$V_{DDQ}$	$V_{SS}$	$V_{SS}$	$V_{SS}$	$V_{DDQ}$	NC	NC	Q2
<b>M</b>	NC	NC	D16	$V_{SS}$	$V_{SS}$	$V_{SS}$	$V_{SS}$	$V_{SS}$	NC	Q1	D2
<b>N</b>	NC	D17	Q16	$V_{SS}$	A	A	A	$V_{SS}$	NC	NC	D1
<b>P</b>	NC	NC	Q17	A	A	C	A	A	NC	D0	Q0
<b>R</b>	TDO	TCK	A	A	A	$\overline{\text{C}}$	A	A	A	TMS	TDI

**CY7C1415AV18 (1M x 36)–15 x 17FBGA**

	1	2	3	4	5	6	7	8	9	10	11
<b>A</b>	CQ	NC/288M	NC/72M	$\overline{\text{WPS}}$	$\overline{\text{BWS}}_2$	$\overline{\text{K}}$	$\overline{\text{BWS}}_1$	$\overline{\text{RPS}}$	A	NC/144M	CQ
<b>B</b>	Q27	Q18	D18	A	$\overline{\text{BWS}}_3$	K	$\overline{\text{BWS}}_0$	A	D17	Q17	Q8
<b>C</b>	D27	Q28	D19	$V_{SS}$	A	NC	A	$V_{SS}$	D16	Q7	D8
<b>D</b>	D28	D20	Q19	$V_{SS}$	$V_{SS}$	$V_{SS}$	$V_{SS}$	$V_{SS}$	Q16	D15	D7
<b>E</b>	Q29	D29	Q20	$V_{DDQ}$	$V_{SS}$	$V_{SS}$	$V_{SS}$	$V_{DDQ}$	Q15	D6	Q6
<b>F</b>	Q30	Q21	D21	$V_{DDQ}$	$V_{DD}$	$V_{SS}$	$V_{DD}$	$V_{DDQ}$	D14	Q14	Q5
<b>G</b>	D30	D22	Q22	$V_{DDQ}$	$V_{DD}$	$V_{SS}$	$V_{DD}$	$V_{DDQ}$	Q13	D13	D5
<b>H</b>	$\overline{\text{DOFF}}$	$V_{REF}$	$V_{DDQ}$	$V_{DDQ}$	$V_{DD}$	$V_{SS}$	$V_{DD}$	$V_{DDQ}$	$V_{DDQ}$	$V_{REF}$	ZQ
<b>J</b>	D31	Q31	D23	$V_{DDQ}$	$V_{DD}$	$V_{SS}$	$V_{DD}$	$V_{DDQ}$	D12	Q4	D4
<b>K</b>	Q32	D32	Q23	$V_{DDQ}$	$V_{DD}$	$V_{SS}$	$V_{DD}$	$V_{DDQ}$	Q12	D3	Q3
<b>L</b>	Q33	Q24	D24	$V_{DDQ}$	$V_{SS}$	$V_{SS}$	$V_{SS}$	$V_{DDQ}$	D11	Q11	Q2
<b>M</b>	D33	Q34	D25	$V_{SS}$	$V_{SS}$	$V_{SS}$	$V_{SS}$	$V_{SS}$	D10	Q1	D2
<b>N</b>	D34	D26	Q25	$V_{SS}$	A	A	A	$V_{SS}$	Q10	D9	D1
<b>P</b>	Q35	D35	Q26	A	A	C	A	A	Q9	D0	Q0
<b>R</b>	TDO	TCK	A	A	A	$\overline{\text{C}}$	A	A	A	TMS	TDI



Pin Definitions

Pin Name	I/O	Pin Description
D <sub>[x:0]</sub>	Input-Synchronous	<b>Data input signals, sampled on the rising edge of K and <math>\bar{K}</math> clocks during valid write operations.</b> CY7C1411V18 – D <sub>[7:0]</sub> CY7C1426V18 – D <sub>[8:0]</sub> CY7C1413V18 – D <sub>[17:0]</sub> CY7C1415V18 – D <sub>[35:0]</sub>
WPS	Input-Synchronous	<b>Write Port Select, active LOW.</b> Sampled on the rising edge of the K clock. When asserted active, a Write operation is initiated. Deasserting will deselect the Write port. Deselecting the Write port will cause D <sub>[x:0]</sub> to be ignored.
NWS <sub>0</sub> , NWS <sub>1</sub> ,	Input-Synchronous	<b>Nibble Write Select 0, 1 – active LOW. (CY7C1411V18 Only)</b> Sampled on the rising edge of the $\bar{K}$ and K clocks during Write operations. Used to select which nibble is written into the device NWS <sub>0</sub> controls D <sub>[3:0]</sub> and NWS <sub>1</sub> controls D <sub>[7:4]</sub> . All the Nibble Write Selects are sampled on the same edge as the data. Deselecting a Nibble Write Select will cause the corresponding nibble of data to be ignored and not written into the device.
$\bar{BWS}_0$ , $\bar{BWS}_1$ , BWS <sub>2</sub> , BWS <sub>3</sub>	Input-Synchronous	<b>Byte Write Select 0, 1, 2, and 3 – active LOW.</b> Sampled on the rising edge of the K and $\bar{K}$ clocks during Write operations. Used to select which byte is written into the device during the current portion of the Write operations. Bytes not written remain unaltered. CY7C1426V18 – $\bar{BWS}_0$ controls D <sub>[8:0]</sub> CY7C1413V18 – $\bar{BWS}_0$ controls D <sub>[8:0]</sub> and $\bar{BWS}_1$ controls D <sub>[17:9]</sub> CY7C1415V18 – $\bar{BWS}_0$ controls D <sub>[8:0]</sub> , $\bar{BWS}_1$ controls D <sub>[17:9]</sub> , $\bar{BWS}_2$ controls D <sub>[26:18]</sub> and $\bar{BWS}_3$ controls D <sub>[35:27]</sub> . All the Byte Write Selects are sampled on the same edge as the data. Deselecting a Byte Write Select will cause the corresponding byte of data to be ignored and not written into the device.
A	Input-Synchronous	<b>Address Inputs.</b> Sampled on the rising edge of the K clock during active Read and Write operations. These address inputs are multiplexed for both Read and Write operations. Internally, the device is organized as 4M x 8 (4 arrays each of 1M x 8) for CY7C1411V18, 4M x 9 (4 arrays each of 1M x 9) for CY7C1426V18, 2M x 18 (4 arrays each of 512K x 18) for CY7C1413V18 and 1M x 36 (4 arrays each of 256K x 36) for CY7C1415V18. Therefore, only 20 address inputs are needed to access the entire memory array of CY7C1411V18 and CY7C1426V18, 19 address inputs for CY7C1413V18 and 18 address inputs for CY7C1415V18. These inputs are ignored when the appropriate port is deselected.
Q <sub>[x:0]</sub>	Outputs-Synchronous	<b>Data Output signals.</b> These pins drive out the requested data during a Read operation. Valid data is driven out on the rising edge of both the C and $\bar{C}$ clocks during Read operations or K and $\bar{K}$ . when in single clock mode. When the Read port is deselected, Q <sub>[x:0]</sub> are automatically tri-stated. CY7C1411V18 – Q <sub>[7:0]</sub> CY7C1426V18 – Q <sub>[8:0]</sub> CY7C1413V18 – Q <sub>[17:0]</sub> CY7C1415V18 – Q <sub>[35:0]</sub>
RPS	Input-Synchronous	<b>Read Port Select, active LOW.</b> Sampled on the rising edge of Positive Input Clock (K). When active, a Read operation is initiated. Deasserting will cause the Read port to be deselected. When deselected, the pending access is allowed to complete and the output drivers are automatically tri-stated following the next rising edge of the C clock. Each Read access consists of a burst of four sequential transfers.
C	Input-Clock	<b>Positive Output Clock Input.</b> C is used in conjunction with $\bar{C}$ to clock out the Read data from the device. C and $\bar{C}$ can be used together to deskew the flight times of various devices on the board back to the controller. See application example for further details.
$\bar{C}$	Input-Clock	<b>Negative Output Clock Input.</b> $\bar{C}$ is used in conjunction with C to clock out the Read data from the device. C and $\bar{C}$ can be used together to deskew the flight times of various devices on the board back to the controller. See application example for further details.
K	Input-Clock	<b>Positive Input Clock Input.</b> The rising edge of K is used to capture synchronous inputs to the device and to drive out data through Q <sub>[x:0]</sub> when in single clock mode. All accesses are initiated on the rising edge of K.
$\bar{K}$	Input-Clock	<b>Negative Input Clock Input.</b> $\bar{K}$ is used to capture synchronous inputs being presented to the device and to drive out data through Q <sub>[x:0]</sub> when in single clock mode.



Pin Definitions (continued)

Pin Name	I/O	Pin Description
CQ	Echo Clock	<b>CQ is referenced with respect to C.</b> This is a free running clock and is synchronized to the output clock (C) of the QDR-II. In the single clock mode, CQ is generated with respect to K. The timings for the echo clocks are shown in the AC Timing table.
$\overline{CQ}$	Echo Clock	<b>CQ is referenced with respect to <math>\overline{C}</math>.</b> This is a free running clock and is synchronized to the output clock ( $\overline{C}$ ) of the QDR-II. In the single clock mode, $\overline{CQ}$ is generated with respect to K. The timings for the echo clocks are shown in the AC Timing table.
ZQ	Input	<b>Output Impedance Matching Input.</b> This input is used to tune the device outputs to the system data bus impedance. CQ, $\overline{CQ}$ , and $Q_{[x:0]}$ output impedance are set to $0.2 \times RQ$ , where RQ is a resistor connected between ZQ and ground. Alternately, this pin can be connected directly to $V_{DD}$ , which enables the minimum impedance mode. This pin cannot be connected directly to GND or left unconnected.
$\overline{DOFF}$	Input	<b>DLL Turn Off - active LOW.</b> Connecting this pin to ground will turn off the DLL inside the device. The timings in the DLL turned off operation will be different from those listed in this data sheet. More details on this operation can be found in the application note, "DLL Operation in the QDR-II."
TDO	Output	<b>TDO for JTAG.</b>
TCK	Input	<b>TCK pin for JTAG.</b>
TDI	Input	<b>TDI pin for JTAG.</b>
TMS	Input	<b>TMS pin for JTAG.</b>
NC	N/A	<b>Not connected to the die.</b> Can be tied to any voltage level.
NC/72M	N/A	<b>Not connected to the die.</b> Can be tied to any voltage level.
NC/144M	N/A	<b>Not connected to the die.</b> Can be tied to any voltage level.
NC/288M	N/A	<b>Not connected to the die.</b> Can be tied to any voltage level.
$V_{REF}$	Input-Reference	<b>Reference Voltage Input.</b> Static input used to set the reference level for HSTL inputs and outputs as well as AC measurement points.
$V_{DD}$	Power Supply	<b>Power supply inputs to the core of the device.</b>
$V_{SS}$	Ground	<b>Ground for the device.</b>
$V_{DDQ}$	Power Supply	<b>Power supply inputs for the outputs of the device.</b>

Functional Overview

The CY7C1411V18, CY7C1426V18, CY7C1413V18, CY7C1415V18 are synchronous pipelined Burst SRAMs equipped with both a Read port and a Write port. The Read port is dedicated to Read operations and the Write port is dedicated to Write operations. Data flows into the SRAM through the Write port and out through the Read port. These devices multiplex the address inputs in order to minimize the number of address pins required. By having separate Read and Write ports, the QDR-II completely eliminates the need to "turn-around" the data bus and avoids any possible data contention, thereby simplifying system design. Each access consists of four 8-bit data transfers in the case of CY7C1411V18, four 9-bit data transfers in the case of CY7C1426V18, four 18-bit data transfers in the case of CY7C1413V18, and four 36-bit data in the case of CY7C1415V18 transfers in two clock cycles.

Accesses for both ports are initiated on the Positive Input Clock (K). All synchronous input timing is referenced from the rising edge of the input clocks (K and  $\overline{K}$ ) and all output timing is referenced to the output clocks (C and  $\overline{C}$  or K and  $\overline{K}$  when in single clock mode).

All synchronous data inputs ( $D_{[x:0]}$ ) inputs pass through input registers controlled by the input clocks (K and  $\overline{K}$ ). All

synchronous data outputs ( $Q_{[x:0]}$ ) outputs pass through output registers controlled by the rising edge of the output clocks (C and  $\overline{C}$  or K and  $\overline{K}$  when in single-clock mode).

All synchronous control ( $\overline{RPS}$ ,  $\overline{WPS}$ ,  $\overline{BWS}_{[x:0]}$ ) inputs pass through input registers controlled by the rising edge of the input clocks (K and  $\overline{K}$ ).

CY7C1413V18 is described in the following sections. The same basic descriptions apply to CY7C1411V18, CY7C1426V18, and CY7C1415V18.

Read Operations

The CY7C1413V18 is organized internally as 4 arrays of 512K x 18. Accesses are completed in a burst of four sequential 18-bit data words. Read operations are initiated by asserting  $\overline{RPS}$  active at the rising edge of the Positive Input Clock (K). The address presented to Address inputs are stored in the Read address register. Following the next K clock rise, the corresponding lowest order 18-bit word of data is driven onto the  $Q_{[17:0]}$  using  $\overline{C}$  as the output timing reference. On the subsequent rising edge of C the next 18-bit data word is driven onto the  $Q_{[17:0]}$ . This process continues until all four 18-bit data words have been driven out onto  $Q_{[17:0]}$ . The requested data will be valid 0.45 ns from the rising edge of the output clock (C or  $\overline{C}$  or (K or  $\overline{K}$  when in single-clock mode)). In order to



maintain the internal logic, each read access must be allowed to complete. Each Read access consists of four 18-bit data words and takes 2 clock cycles to complete. Therefore, Read accesses to the device can not be initiated on two consecutive K clock rises. The internal logic of the device will ignore the second Read request. Read accesses can be initiated on every other K clock rise. Doing so will pipeline the data flow such that data is transferred out of the device on every rising edge of the output clocks (C and  $\bar{C}$  or K and  $\bar{K}$  when in single-clock mode).

When the read port is deselected, the CY7C1413V18 will first complete the pending Read transactions. Synchronous internal circuitry will automatically tri-state the outputs following the next rising edge of the Positive Output Clock (C). This will allow for a seamless transition between devices without the insertion of wait states in a depth expanded memory.

### Write Operations

Write operations are initiated by asserting  $\overline{WPS}$  active at the rising edge of the Positive Input Clock (K). On the following K clock rise the data presented to  $D_{[17:0]}$  is latched and stored into the lower 18-bit Write Data register, provided  $BWS_{[1:0]}$  are both asserted active. On the subsequent rising edge of the Negative Input Clock ( $\bar{K}$ ) the information presented to  $D_{[17:0]}$  is also stored into the Write Data register, provided  $\overline{BWS}_{[1:0]}$  are both asserted active. This process continues for one more cycle until four 18-bit words (a total of 72 bits) of data are stored in the SRAM. The 72 bits of data are then written into the memory array at the specified location. Therefore, Write accesses to the device can not be initiated on two consecutive K clock rises. The internal logic of the device will ignore the second Write request. Write accesses can be initiated on every other rising edge of the Positive Input Clock (K). Doing so will pipeline the data flow such that 18 bits of data can be transferred into the device on every rising edge of the input clocks (K and  $\bar{K}$ ).

When deselected, the Write port will ignore all inputs after the pending Write operations have been completed.

### Byte Write Operations

Byte Write operations are supported by the CY7C1413V18. A Write operation is initiated as described in the Write Operations section above. The bytes that are written are determined by  $BWS_0$  and  $BWS_1$ , which are sampled with each set of 18-bit data words. Asserting the appropriate Byte Write Select input during the data portion of a Write will allow the data being presented to be latched and written into the device. Deasserting the Byte Write Select input during the data portion of a write will allow the data stored in the device for that byte to remain unaltered. This feature can be used to simplify Read/Modify/Write operations to a Byte Write operation.

### Single Clock Mode

The CY7C1413V18 can be used with a single clock that controls both the input and output registers. In this mode the device will recognize only a single pair of input clocks (K and  $\bar{K}$ ) that control both the input and output registers. This operation is identical to the operation if the device had zero skew between the  $K/\bar{K}$  and  $C/\bar{C}$  clocks. All timing parameters remain the same in this mode. To use this mode of operation, the user must tie C and  $\bar{C}$  HIGH at power on. This function is a strap option and not alterable during device operation.

### Concurrent Transactions

The Read and Write ports on the CY7C1413V18 operate completely independently of one another. Since each port latches the address inputs on different clock edges, the user can Read or Write to any location, regardless of the transaction on the other port. If the ports access the same location when a Read follows a Write in successive clock cycles, the SRAM will deliver the most recent information associated with the specified address location. This includes forwarding data from a Write cycle that was initiated on the previous K clock rise.

Read accesses and Write access must be scheduled such that one transaction is initiated on any clock cycle. If both ports are selected on the same K clock rise, the arbitration depends on the previous state of the SRAM. If both ports were deselected, the Read port will take priority. If a Read was initiated on the previous cycle, the Write port will assume priority (since Read operations can not be initiated on consecutive cycles). If a Write was initiated on the previous cycle, the Read port will assume priority (since Write operations can not be initiated on consecutive cycles). Therefore, asserting both port selects active from a deselected state will result in alternating Read/Write operations being initiated, with the first access being a Read.

### Depth Expansion

The CY7C1413V18 has a Port Select input for each port. This allows for easy depth expansion. Both Port Selects are sampled on the rising edge of the Positive Input Clock only (K). Each port select input can deselect the specified port. Deselecting a port will not affect the other port. All pending transactions (Read and Write) will be completed prior to the device being deselected.

### Programmable Impedance

An external resistor, RQ, must be connected between the ZQ pin on the SRAM and  $V_{SS}$  to allow the SRAM to adjust its output driver impedance. The value of RQ must be 5X the value of the intended line impedance driven by the SRAM. The allowable range of RQ to guarantee impedance matching with a tolerance of  $\pm 15\%$  is between  $175\Omega$  and  $350\Omega$ , with  $V_{DDQ} = 1.5V$ . The output impedance is adjusted every 1024 cycles upon power-up to account for drifts in supply voltage and temperature.

### Echo Clocks

Echo clocks are provided on the QDR-II to simplify data capture on high-speed systems. Two echo clocks are generated by the QDR-II. CQ is referenced with respect to C and  $\bar{C}Q$  is referenced with respect to  $\bar{C}$ . These are free running clocks and are synchronized to the output clock of the QDR-II. In the single clock mode, CQ is generated with respect to K and  $\bar{C}Q$  is generated with respect to  $\bar{K}$ . The timings for the echo clocks are shown in the AC Timing table.

### DLL

These chips utilize a Delay Lock Loop (DLL) that is designed to function between 80 MHz and the specified maximum clock frequency. The DLL may be disabled by applying ground to the  $\overline{DOFF}$  pin. The DLL can also be reset by slowing the cycle time of input clocks K and  $\bar{K}$  to greater than 30 ns.

**Application Example<sup>[1]</sup>**

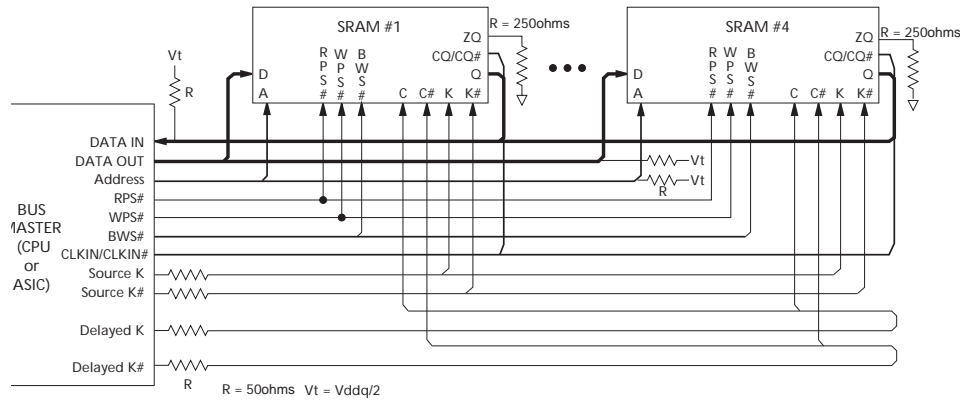

**Truth Table<sup>[2, 3, 4, 5, 6, 7]</sup>**

Operation	K	RPS	WPS	DQ	DQ	DQ	DQ
Write Cycle: Load address on the rising edge of K; input write data on two consecutive K and $\bar{K}$ rising edges.	L-H	H <sup>[8]</sup>	L <sup>[9]</sup>	D(A) at K(t+1) ↑	D(A + 1) at K(t+1) ↑	D(A + 2) at K(t + 2) ↑	D(A + 3) at K(t + 2) ↑
Read Cycle: Load address on the rising edge of K; wait one and a half cycle; read data on two consecutive C and $\bar{C}$ rising edges.	L-H	L <sup>[9]</sup>	X	Q(A) at C(t + 1) ↑	Q(A + 1) at C(t + 2) ↑	Q(A + 2) at $\bar{C}(t + 2)$ ↑	Q(A + 3) at C(t + 3) ↑
NOP: No Operation	L-H	H	H	D = X Q = High-Z	D = X Q = High-Z	D = X Q = High-Z	D = X Q = High-Z
Standby: Clock Stopped	Stopped	X	X	Previous State	Previous State	Previous State	Previous State

**Write Cycle Descriptions** CY7C1411V18 and CY7C1413V18) <sup>[2, 10]</sup>

$\overline{BWS}_0/\overline{NWS}_0$	$\overline{BWS}_1/\overline{NWS}_1$	K	$\bar{K}$	Comments
L	L	L-H	-	During the Data portion of a Write sequence: CY7C1411V18 – both nibbles (D <sub>[7:0]</sub> ) are written into the device, CY7C1413V18 – both bytes (D <sub>[17:0]</sub> ) are written into the device.
L	L	-	L-H	During the Data portion of a Write sequence: CY7C1411V18 – both nibbles (D <sub>[7:0]</sub> ) are written into the device, CY7C1413V18 – both bytes (D <sub>[17:0]</sub> ) are written into the device.

**Notes:**

- The above application shows four QDR-II being used.
- X = "Don't Care," H = Logic HIGH, L = Logic LOW, ↑ represents rising edge.
- Device will power-up deselected and the outputs in a tri-state condition.
- "A" represents address location latched by the devices when transaction was initiated. A + 1, A + 2, and A + 3 represents the address sequence in the burst.
- "t" represents the cycle at which a Read/write operation is started. t + 1, t + 2, and t + 3 are the first, second and third clock cycles respectively succeeding the "t" clock cycle.
- Data inputs are registered at K and  $\bar{K}$  rising edges. Data outputs are delivered on C and  $\bar{C}$  rising edges, except when in single clock mode.
- It is recommended that K = K and C =  $\bar{C}$  = HIGH when clock is stopped. This is not essential, but permits most rapid restart by overcoming transmission line charging symmetrically.
- If this signal was LOW to initiate the previous cycle, this signal becomes a "Don't Care" for this operation.
- This signal was HIGH on previous K clock rise. Initiating consecutive Read or Write operations on consecutive K clock rises is not permitted. The device will ignore the second Read or Write request.
- Assumes a Write cycle was initiated per the Write Port Cycle Description Truth Table.  $\overline{NWS}_0$ ,  $\overline{NWS}_1$ ,  $\overline{BWS}_0$ ,  $\overline{BWS}_1$ ,  $\overline{BWS}_2$  and  $\overline{BWS}_3$  can be altered on different portions of a Write cycle, as long as the set-up and hold requirements are achieved.



**PRELIMINARY**

**CY7C1411V18  
CY7C1426V18  
CY7C1413V18  
CY7C1415V18**

**Write Cycle Descriptions** CY7C1411V18 and CY7C1413V18) (continued)<sup>[2, 10]</sup>

$\overline{BWS}_0/\overline{NWS}_0$	$\overline{BWS}_1/\overline{NWS}_1$	K	$\overline{K}$	Comments
L	H	L-H	-	During the Data portion of a Write sequence : CY7C1411V18 – only the lower nibble (D <sub>[3:0]</sub> ) is written into the device. D <sub>[7:4]</sub> will remain unaltered, CY7C1413V18 – only the lower byte (D <sub>[8:0]</sub> ) is written into the device. D <sub>[17:9]</sub> will remain unaltered.
L	H	-	L-H	During the Data portion of a Write sequence : CY7C1411V18 – only the lower nibble (D <sub>[3:0]</sub> ) is written into the device. D <sub>[7:4]</sub> will remain unaltered, CY7C1413V18 – only the lower byte (D <sub>[8:0]</sub> ) is written into the device. D <sub>[17:9]</sub> will remain unaltered.
H	L	L-H	-	During the Data portion of a Write sequence : CY7C1411V18 – only the upper nibble (D <sub>[7:4]</sub> ) is written into the device. D <sub>[3:0]</sub> will remain unaltered, CY7C1413V18 – only the upper byte (D <sub>[17:9]</sub> ) is written into the device. D <sub>[8:0]</sub> will remain unaltered.
H	L	-	L-H	During the Data portion of a Write sequence : CY7C1411V18 – only the upper nibble (D <sub>[7:4]</sub> ) is written into the device. D <sub>[3:0]</sub> will remain unaltered, CY7C1413V18 – only the upper byte (D <sub>[17:9]</sub> ) is written into the device. D <sub>[8:0]</sub> will remain unaltered.
H	H	L-H	-	No data is written into the devices during this portion of a write operation.
H	H	-	L-H	No data is written into the devices during this portion of a write operation.

**Write Cycle Descriptions**<sup>[2, 10]</sup>(CY7C1415V18)

$\overline{BWS}_0$	$\overline{BWS}_1$	$\overline{BWS}_2$	$\overline{BWS}_3$	K	$\overline{K}$	Comments
L	L	L	L	L-H	-	During the Data portion of a Write sequence, all four bytes (D <sub>[35:0]</sub> ) are written into the device.
L	L	L	L	-	L-H	During the Data portion of a Write sequence, all four bytes (D <sub>[35:0]</sub> ) are written into the device.
L	H	H	H	L-H	-	During the Data portion of a Write sequence, only the lower byte (D <sub>[8:0]</sub> ) is written into the device. D <sub>[35:9]</sub> will remain unaltered.
L	H	H	H	-	L-H	During the Data portion of a Write sequence, only the lower byte (D <sub>[8:0]</sub> ) is written into the device. D <sub>[35:9]</sub> will remain unaltered.
H	L	H	H	L-H	-	During the Data portion of a Write sequence, only the byte (D <sub>[17:9]</sub> ) is written into the device. D <sub>[8:0]</sub> and D <sub>[35:18]</sub> will remain unaltered.
H	L	H	H	-	L-H	During the Data portion of a Write sequence, only the byte (D <sub>[17:9]</sub> ) is written into the device. D <sub>[8:0]</sub> and D <sub>[35:18]</sub> will remain unaltered.
H	H	L	H	L-H	-	During the Data portion of a Write sequence, only the byte (D <sub>[26:18]</sub> ) is written into the device. D <sub>[17:0]</sub> and D <sub>[35:27]</sub> will remain unaltered.
H	H	L	H	-	L-H	During the Data portion of a Write sequence, only the byte (D <sub>[26:18]</sub> ) is written into the device. D <sub>[17:0]</sub> and D <sub>[35:27]</sub> will remain unaltered.
H	H	H	L	L-H	-	During the Data portion of a Write sequence, only the byte (D <sub>[35:27]</sub> ) is written into the device. D <sub>[26:0]</sub> will remain unaltered.
H	H	H	L	-	L-H	During the Data portion of a Write sequence, only the byte (D <sub>[35:27]</sub> ) is written into the device. D <sub>[26:0]</sub> will remain unaltered.
H	H	H	H	L-H	-	No data is written into the device during this portion of a write operation.
H	H	H	H	-	L-H	No data is written into the device during this portion of a write operation.



**PRELIMINARY**

**CY7C1411V18  
CY7C1426V18  
CY7C1413V18  
CY7C1415V18**

**Write Cycle Descriptions<sup>[2, 10]</sup> (CY7C1426V18)**

$\overline{\text{BWS}}_0$	K	$\overline{\text{K}}$	
L	L-H	-	During the Data portion of a Write sequence, the single byte ( $D_{[8:0]}$ ) is written into the device.
L	-	L-H	During the Data portion of a Write sequence, the single byte ( $D_{[8:0]}$ ) is written into the device.
H	L-H	-	No data is written into the device during this portion of a write operation.
H	-	L-H	No data is written into the device during this portion of a write operation.



**PRELIMINARY**

**CY7C1411V18  
CY7C1426V18  
CY7C1413V18  
CY7C1415V18**

**Maximum Ratings** (Above which the useful life may be impaired.)

Storage Temperature ..... -65°C to +150°C  
 Ambient Temperature with Power Applied .... -10°C to +85°C  
 Supply Voltage on V<sub>DD</sub> Relative to GND..... -0.5V to +2.9V  
 DC Applied to Outputs in High-Z ..... -0.5V to V<sub>DDQ</sub> + 0.3V  
 DC Input Voltage<sup>[14]</sup> ..... -0.5V to V<sub>DDQ</sub> + 0.3V  
 Current into Outputs (LOW) ..... 20 mA

Static Discharge Voltage (MIL-STD-883, M. 3015)... >2001V  
 Latch-up Current..... >200 mA

**Operating Range**

Range	Ambient Temperature (T <sub>A</sub> )	V <sub>DD</sub> <sup>[15]</sup>	V <sub>DDQ</sub> <sup>[15]</sup>
Com'l	0°C to +70°C	1.8 ± 0.1V	1.4V to V <sub>DD</sub>

**DC Electrical Characteristics** Over the Operating Range<sup>[11]</sup>

Parameter	Description	Test Conditions	Min.	Typ.	Max.	Unit
V <sub>DD</sub>	Power Supply Voltage		1.7	1.8	1.9	V
V <sub>DDQ</sub>	I/O Supply Voltage		1.4	1.5	V <sub>DD</sub>	V
V <sub>OH</sub>	Output HIGH Voltage	Note 12	V <sub>DDQ</sub> /2 - 0.12		V <sub>DDQ</sub> /2 + 0.12	V
V <sub>OL</sub>	Output LOW Voltage	Note 13	V <sub>DDQ</sub> /2 - 0.12		V <sub>DDQ</sub> /2 + 0.12	V
V <sub>OH(LOW)</sub>	Output HIGH Voltage	I <sub>OH</sub> = -0.1 mA, Nominal Impedance	V <sub>DDQ</sub> - 0.2		V <sub>DDQ</sub>	V
V <sub>OL(LOW)</sub>	Output LOW Voltage	I <sub>OL</sub> = 0.1 mA, Nominal Impedance	V <sub>SS</sub>		0.2	V
V <sub>IH</sub>	Input HIGH Voltage <sup>[14]</sup>		V <sub>REF</sub> + 0.1		V <sub>DDQ</sub> + 0.3	V
V <sub>IL</sub>	Input LOW Voltage <sup>[14]</sup>		-0.3		V <sub>REF</sub> - 0.1	V
I <sub>X</sub>	Input Load Current	GND ≤ V <sub>I</sub> ≤ V <sub>DDQ</sub>	-5		5	μA
I <sub>OZ</sub>	Output Leakage Current	GND ≤ V <sub>I</sub> ≤ V <sub>DDQ</sub> , Output Disabled	-5		5	μA
V <sub>REF</sub>	Input Reference Voltage <sup>[16]</sup>	Typical Value = 0.75V	0.68	0.75	0.95	V
I <sub>DD</sub>	V <sub>DD</sub> Operating Supply	V <sub>DD</sub> = Max., I <sub>OUT</sub> = 0 mA, f = f <sub>MAX</sub> = 1/t <sub>CYC</sub>	167 MHz		TBD	mA
			200 MHz		TBD	mA
			250 MHz		TBD	mA
I <sub>SB1</sub>	Automatic Power-down Current	Max. V <sub>DD</sub> , Both Ports Deselected, V <sub>IN</sub> ≥ V <sub>IH</sub> or V <sub>IN</sub> ≤ V <sub>IL</sub> f = f <sub>MAX</sub> = 1/t <sub>CYC</sub> , Inputs Static	167 MHz		TBD	mA
			200 MHz		TBD	mA
			250 MHz		TBD	mA

**Notes:**

- 11. All Voltage referenced to Ground.
- 12. Output are impedance controlled. I<sub>OH</sub> = -(V<sub>DDQ</sub>/2)/(RQ/5) for values of 175Ω ≤ RQ ≤ 350Ωs.
- 13. Output are impedance controlled. I<sub>OL</sub> = (V<sub>DDQ</sub>/2)/(RQ/5) for values of 175Ω ≤ RQ ≤ 350Ωs.
- 14. Overshoot: V<sub>IH(AC)</sub> < V<sub>DDQ</sub> + 0.85V (Pulse width less than t<sub>CYC</sub>/2), Undershoot: V<sub>IL(AC)</sub> > -1.5V (Pulse width less than t<sub>CYC</sub>/2).
- 15. Power-up: Assumes a linear ramp from 0V to V<sub>DD</sub>(min.) within 200 ms. During this time V<sub>IH</sub> < V<sub>DD</sub> and V<sub>DDQ</sub> < V<sub>DD</sub>.
- 16. V<sub>REF</sub> (Min.) = 0.68V or 0.46V<sub>DDQ</sub>, whichever is larger, V<sub>REF</sub> (Max.) = 0.95V or 0.54V<sub>DDQ</sub>, whichever is smaller.



PRELIMINARY

CY7C1411V18  
CY7C1426V18  
CY7C1413V18  
CY7C1415V18

**AC Electrical Characteristics** Over the Operating Range

Parameter	Description	Test Conditions	Min.	Typ.	Max.	Unit
V <sub>IH</sub>	Input High (Logic 1) Voltage		V <sub>REF</sub> + 0.2	–	–	V
V <sub>IL</sub>	Input Low (Logic 0) Voltage		–	–	V <sub>REF</sub> – 0.2	V

**Switching Characteristics** Over the Operating Range<sup>[17, 18]</sup>

Cypress Parameter	Consortium Parameter	Description	250 MHz		200 MHz		167 MHz		Unit
			Min.	Max.	Min.	Max.	Min.	Max.	
t <sub>POWER</sub>		V <sub>DD</sub> (Typical) to the First Access <sup>[21]</sup>	1		1		1		ms
t <sub>CYC</sub>	t <sub>KHKH</sub>	K Clock and C Clock Cycle Time	4.0	6.3	5.0	7.9	6.0	8.4	ns
t <sub>KH</sub>	t <sub>KHKL</sub>	Input Clock (K/ $\bar{K}$ ; C/ $\bar{C}$ ) HIGH	1.6	–	2.0	–	2.4	–	ns
t <sub>KL</sub>	t <sub>KLKH</sub>	Input Clock (K/ $\bar{K}$ ; C/ $\bar{C}$ ) LOW	1.6	–	2.0	–	2.4	–	ns
t <sub>KH<math>\bar{K}</math>H</sub>	t <sub>KH<math>\bar{K}</math>H</sub>	K Clock Rise to $\bar{K}$ Clock Rise and C to $\bar{C}$ Rise (rising edge to rising edge)	1.8	–	2.2	–	2.7	–	ns
t <sub>KHCH</sub>	t <sub>KHCH</sub>	K/ $\bar{K}$ Clock Rise to C/ $\bar{C}$ Clock Rise (rising edge to rising edge)	0.0	1.8	0.0	2.2	0.0	2.7	ns
<b>Set-up Times</b>									
t <sub>SA</sub>	t <sub>SA</sub>	Address Set-up to K Clock Rise	0.5	–	0.6	–	0.7	–	ns
t <sub>SC</sub>	t <sub>SC</sub>	Control Set-up to Clock (K, $\bar{K}$ ) Rise ( $\bar{RPS}$ , $\bar{WPS}$ )	0.5	–	0.6	–	0.7	–	ns
t <sub>SCDDR</sub>	t <sub>SC</sub>	Double Data Rate Control Set-up to Clock (K, $\bar{K}$ ) Rise ( $\bar{BWS}_0$ , $\bar{BWS}_1$ , $\bar{BWS}_2$ , $\bar{BWS}_3$ )	0.35	–	0.4	–	0.5	–	ns
t <sub>SD</sub>	t <sub>SD</sub>	D <sub>[x:0]</sub> Set-up to Clock (K/ $\bar{K}$ ) Rise	0.35	–	0.4	–	0.5	–	ns
<b>Hold Times</b>									
t <sub>HA</sub>	t <sub>HA</sub>	Address Hold after Clock (K/ $\bar{K}$ ) Rise	0.5	–	0.6	–	0.7	–	ns
t <sub>HC</sub>	t <sub>HC</sub>	Control Hold after Clock (K/ $\bar{K}$ ) Rise ( $\bar{RPS}$ , $\bar{WPS}$ )	0.5	–	0.6	–	0.7	–	ns
t <sub>HCDDR</sub>	t <sub>HC</sub>	Double Data Rate Control Hold after Clock (K/ $\bar{K}$ ) Rise ( $\bar{BWS}_0$ , $\bar{BWS}_1$ , $\bar{BWS}_2$ , $\bar{BWS}_3$ )	0.35	–	0.4	–	0.5	–	ns
t <sub>HD</sub>	t <sub>HD</sub>	D <sub>[x:0]</sub> Hold after Clock (K/ $\bar{K}$ ) Rise	0.35	–	0.4	–	0.5	–	ns
<b>Output Times</b>									
t <sub>CO</sub>	t <sub>CHQV</sub>	C/ $\bar{C}$ Clock Rise (or K/ $\bar{K}$ in single clock mode) to Data Valid	–	0.45	–	0.45	–	0.50	ns
t <sub>DOH</sub>	t <sub>CHQX</sub>	Data Output Hold after Output C/ $\bar{C}$ Clock Rise (Active to Active)	–0.45	–	–0.45	–	–0.50	–	ns
t <sub>CCQO</sub>	t <sub>CHCQV</sub>	C/ $\bar{C}$ Clock Rise to Echo Clock Valid	–	0.45	–	0.45	–	0.50	ns
t <sub>CQOH</sub>	t <sub>CHCQX</sub>	Echo Clock Hold after C/ $\bar{C}$ Clock Rise	–0.45	–	–0.45	–	–0.50	–	ns
t <sub>CQD</sub>	t <sub>CQHCV</sub>	Echo Clock High to Data Valid	–	0.30	–	0.35	–	0.40	ns
t <sub>CQDOH</sub>	t <sub>CQHCV</sub>	Echo Clock High to Data Invalid	–0.30	–	–0.35	–	–0.40	–	ns
t <sub>CHZ</sub>	t <sub>CHZ</sub>	Clock (C and $\bar{C}$ ) Rise to High-Z (Active to High-Z) <sup>[19, 20]</sup>	–	0.45	–	0.45	–	0.50	ns
t <sub>CLZ</sub>	t <sub>CLZ</sub>	Clock (C and $\bar{C}$ ) Rise to Low-Z <sup>[19, 20]</sup>	–0.45	–	–0.45	–	–0.50	–	ns

**Notes:**

17. All devices can operate at clock frequencies as low as 119 MHz. When a part with a maximum frequency above 167 MHz is operating at a lower clock frequency, it requires the input timings of the frequency range in which it is being operated and will output data with the output timings of that frequency range.
18. Unless otherwise noted, test conditions assume signal transition time of 2V/ns, timing reference levels of 0.75V, V<sub>ref</sub> = 0.75V, R<sub>Q</sub> = 250Ω, V<sub>DDQ</sub> = 1.5V, input pulse levels of 0.25V to 1.25V, and output loading of the specified I<sub>OL</sub>/I<sub>OH</sub> and load capacitance shown in (a) of AC Test Loads.
19. t<sub>CHZ</sub>, t<sub>CLZ</sub>, are specified with a load capacitance of 5 pF as in part (b) of AC Test Loads. Transition is measured ± 100 mV from steady-state voltage.
20. At any given voltage and temperature t<sub>CHZ</sub> is less than t<sub>CLZ</sub> and t<sub>CHZ</sub> less than t<sub>CO</sub>.
21. This part has a voltage regulator internally; t<sub>POWER</sub> is the time that the power needs to be supplied above V<sub>DD</sub> minimum initially before a Read or Write operation can be initiated.

**Switching Characteristics** Over the Operating Range<sup>[17, 18]</sup> (continued)

Cypress Parameter	Consortium Parameter	Description	250 MHz		200 MHz		167 MHz		Unit
			Min.	Max.	Min.	Max.	Min.	Max.	
<b>DLL Timing</b>									
t <sub>KC Var</sub>	t <sub>KC Var</sub>	Clock Phase Jitter	–	0.20	–	0.20	–	0.20	ns
t <sub>KC lock</sub>	t <sub>KC lock</sub>	DLL Lock Time (K, C)	1024	–	1024	–	1024	–	cycles
t <sub>KC Reset</sub>	t <sub>KC Reset</sub>	K Static to DLL Reset	30		30		30		ns

**Thermal Resistance**<sup>[22]</sup>

Parameter	Description	Test Conditions	165 FBGA Package	Unit
Θ <sub>JA</sub>	Thermal Resistance (Junction to Ambient)	Test conditions follow standard test methods and procedures for measuring thermal impedance, per EIA/JESD51.	TBD	°C/W
Θ <sub>JC</sub>	Thermal Resistance (Junction to Case)		TBD	°C/W

**Capacitance**<sup>[22]</sup>

Parameter	Description	Test Conditions	Max.	Unit
C <sub>IN</sub>	Input Capacitance	T <sub>A</sub> = 25°C, f = 1 MHz, V <sub>DD</sub> = 1.8V V <sub>DDQ</sub> = 1.5V	TBD	pF
C <sub>CLK</sub>	Clock Input Capacitance		TBD	pF
C <sub>O</sub>	Output Capacitance		TBD	pF

**AC Test Loads and Waveforms**

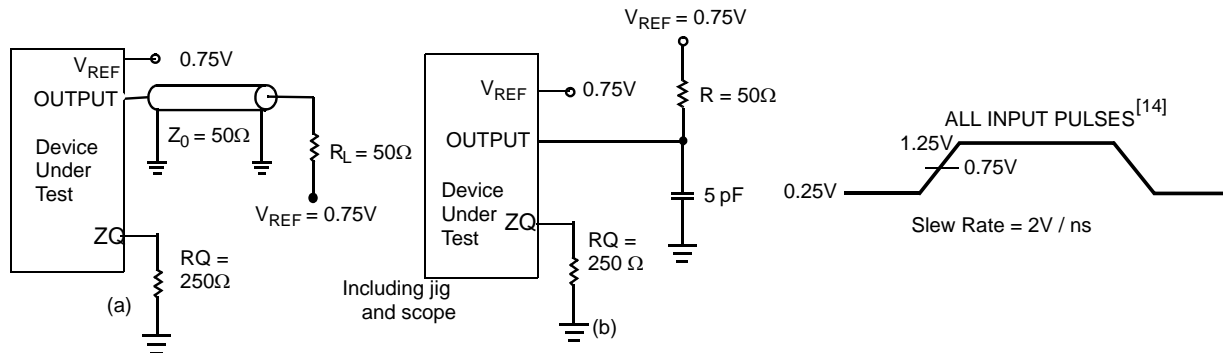

**Note:**  
22. Tested initially and after any design or process change that may affect these parameters.

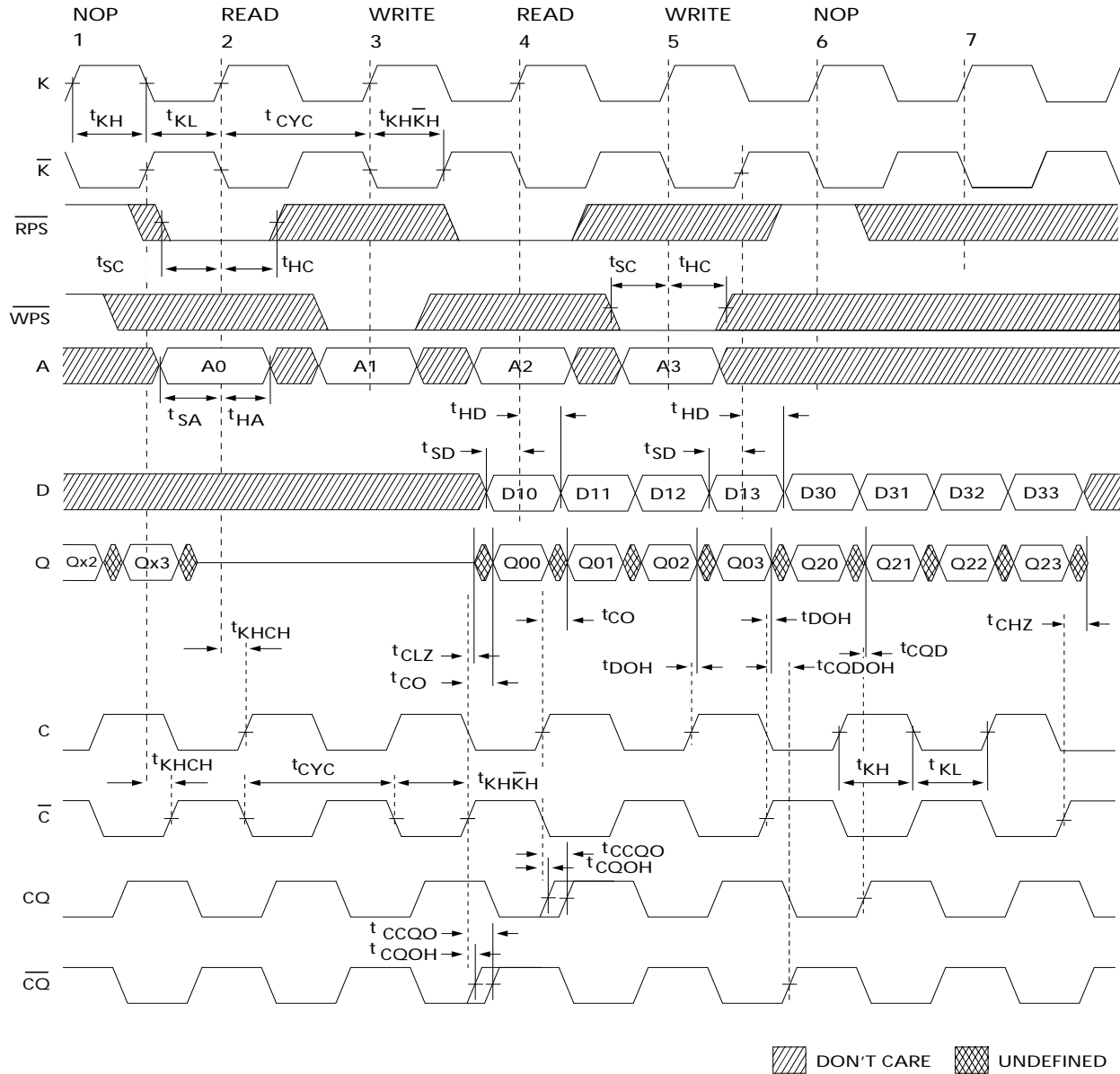
**Switching Waveforms<sup>[23, 24, 25]</sup>**
**Read/Write/Deselect Sequence**

**Notes:**

23. Q00 refers to output from address A0. Q01 refers to output from the next internal burst address following A0, i.e., A0+1.

24. Output are disabled (High-Z) one clock cycle after a NOP.

25. In this example, if address A2 = A1, then data Q20 = D10 and Q21 = D11. Write data is forwarded immediately as read results. This note applies to the whole diagram.



## IEEE 1149.1 Serial Boundary Scan (JTAG)

These SRAMs incorporate a serial boundary scan test access port (TAP) in the FBGA package. This part is fully compliant with IEEE Standard #1149.1-1900. The TAP operates using JEDEC standard 1.8V I/O logic levels.

### Disabling the JTAG Feature

It is possible to operate the SRAM without using the JTAG feature. To disable the TAP controller, TCK must be tied LOW ( $V_{SS}$ ) to prevent clocking of the device. TDI and TMS are internally pulled up and may be unconnected. They may alternately be connected to  $V_{DD}$  through a pull-up resistor. TDO should be left unconnected. Upon power-up, the device will come up in a reset state which will not interfere with the operation of the device.

### Test Access Port—Test Clock

The test clock is used only with the TAP controller. All inputs are captured on the rising edge of TCK. All outputs are driven from the falling edge of TCK.

### Test Mode Select

The TMS input is used to give commands to the TAP controller and is sampled on the rising edge of TCK. It is allowable to leave this pin unconnected if the TAP is not used. The pin is pulled up internally, resulting in a logic HIGH level.

### Test Data-In (TDI)

The TDI pin is used to serially input information into the registers and can be connected to the input of any of the registers. The register between TDI and TDO is chosen by the instruction that is loaded into the TAP instruction register. For information on loading the instruction register, see the TAP Controller State Diagram. TDI is internally pulled up and can be unconnected if the TAP is unused in an application. TDI is connected to the most significant bit (MSB) on any register.

### Test Data-Out (TDO)

The TDO output pin is used to serially clock data-out from the registers. The output is active depending upon the current state of the TAP state machine (see Instruction codes). The output changes on the falling edge of TCK. TDO is connected to the least significant bit (LSB) of any register.

### Performing a TAP Reset

A Reset is performed by forcing TMS HIGH ( $V_{DD}$ ) for five rising edges of TCK. This RESET does not affect the operation of the SRAM and may be performed while the SRAM is operating. At power-up, the TAP is reset internally to ensure that TDO comes up in a high-Z state.

### TAP Registers

Registers are connected between the TDI and TDO pins and allow data to be scanned into and out of the SRAM test circuitry. Only one register can be selected at a time through the instruction registers. Data is serially loaded into the TDI pin on the rising edge of TCK. Data is output on the TDO pin on the falling edge of TCK.

#### *Instruction Register*

Three-bit instructions can be serially loaded into the instruction register. This register is loaded when it is placed between the

TDI and TDO pins as shown in TAP Controller Block Diagram. Upon power-up, the instruction register is loaded with the IDCODE instruction. It is also loaded with the IDCODE instruction if the controller is placed in a reset state as described in the previous section.

When the TAP controller is in the Capture IR state, the two least significant bits are loaded with a binary "01" pattern to allow for fault isolation of the board level serial test path.

#### *Bypass Register*

To save time when serially shifting data through registers, it is sometimes advantageous to skip certain chips. The bypass register is a single-bit register that can be placed between TDI and TDO pins. This allows data to be shifted through the SRAM with minimal delay. The bypass register is set LOW ( $V_{SS}$ ) when the BYPASS instruction is executed.

#### *Boundary Scan Register*

The boundary scan register is connected to all of the input and output pins on the SRAM. Several no connect (NC) pins are also included in the scan register to reserve pins for higher density devices.

The boundary scan register is loaded with the contents of the RAM Input and Output ring when the TAP controller is in the Capture-DR state and is then placed between the TDI and TDO pins when the controller is moved to the Shift-DR state. The EXTEST, SAMPLE/PRELOAD and SAMPLE Z instructions can be used to capture the contents of the Input and Output ring.

The Boundary Scan Order tables show the order in which the bits are connected. Each bit corresponds to one of the bumps on the SRAM package. The MSB of the register is connected to TDI, and the LSB is connected to TDO.

#### *Identification (ID) Register*

The ID register is loaded with a vendor-specific, 32-bit code during the Capture-DR state when the IDCODE command is loaded in the instruction register. The IDCODE is hardwired into the SRAM and can be shifted out when the TAP controller is in the Shift-DR state. The ID register has a vendor code and other information described in the Identification Register Definitions table.

### TAP Instruction Set

Eight different instructions are possible with the three-bit instruction register. All combinations are listed in the Instruction Code table. Three of these instructions are listed as RESERVED and should not be used. The other five instructions are described in detail below.

Instructions are loaded into the TAP controller during the Shift-IR state when the instruction register is placed between TDI and TDO. During this state, instructions are shifted through the instruction register through the TDI and TDO pins. To execute the instruction once it is shifted in, the TAP controller needs to be moved into the Update-IR state.

#### *IDCODE*

The IDCODE instruction causes a vendor-specific, 32-bit code to be loaded into the instruction register. It also places the instruction register between the TDI and TDO pins and allows the IDCODE to be shifted out of the device when the TAP controller enters the Shift-DR state. The IDCODE instruction



is loaded into the instruction register upon power-up or whenever the TAP controller is given a test logic reset state.

**SAMPLE Z**

The SAMPLE Z instruction causes the boundary scan register to be connected between the TDI and TDO pins when the TAP controller is in a Shift-DR state. The SAMPLE Z command puts the output bus into a High-Z state until the next command is given during the "Update IR" state.

**SAMPLE/PRELOAD**

SAMPLE/PRELOAD is a 1149.1 mandatory instruction. When the SAMPLE/PRELOAD instructions are loaded into the instruction register and the TAP controller is in the Capture-DR state, a snapshot of data on the inputs and output pins is captured in the boundary scan register.

The user must be aware that the TAP controller clock can only operate at a frequency up to 20 MHz, while the SRAM clock operates more than an order of magnitude faster. Because there is a large difference in the clock frequencies, it is possible that during the Capture-DR state, an input or output will undergo a transition. The TAP may then try to capture a signal while in transition (metastable state). This will not harm the device, but there is no guarantee as to the value that will be captured. Repeatable results may not be possible.

To guarantee that the boundary scan register will capture the correct value of a signal, the SRAM signal must be stabilized long enough to meet the TAP controller's capture set-up plus hold times ( $t_{CS}$  and  $t_{CH}$ ). The SRAM clock input might not be captured correctly if there is no way in a design to stop (or slow) the clock during a SAMPLE/PRELOAD instruction. If this is an issue, it is still possible to capture all other signals and simply ignore the value of the CK and  $\overline{CK}$  captured in the boundary scan register.

Once the data is captured, it is possible to shift out the data by putting the TAP into the Shift-DR state. This places the boundary scan register between the TDI and TDO pins.

PRELOAD allows an initial data pattern to be placed at the latched parallel outputs of the boundary scan register cells prior to the selection of another boundary scan test operation.

The shifting of data for the SAMPLE and PRELOAD phases can occur concurrently when required—that is, while data captured is shifted out, the preloaded data can be shifted in.

**BYPASS**

When the BYPASS instruction is loaded in the instruction register and the TAP is placed in a Shift-DR state, the bypass register is placed between the TDI and TDO pins. The advantage of the BYPASS instruction is that it shortens the boundary scan path when multiple devices are connected together on a board.

**EXTEST**

The EXTEST instruction enables the preloaded data to be driven out through the system output pins. This instruction also selects the boundary scan register to be connected for serial access between the TDI and TDO in the shift-DR controller state.

**EXTEST OUTPUT BUS TRI-STATE**

IEEE Standard 1149.1 mandates that the TAP controller be able to put the output bus into a tri-state mode.

The boundary scan register has a special bit located at bit #47. When this scan cell, called the "extest output bus tristate", is latched into the preload register during the "Update-DR" state in the TAP controller, it will directly control the state of the output (Q-bus) pins, when the EXTEST is entered as the current instruction. When HIGH, it will enable the output buffers to drive the output bus. When LOW, this bit will place the output bus into a High-Z condition.

This bit can be set by entering the SAMPLE/PRELOAD or EXTEST command, and then shifting the desired bit into that cell, during the "Shift-DR" state. During "Update-DR", the value loaded into that shift-register cell will latch into the preload register. When the EXTEST instruction is entered, this bit will directly control the output Q-bus pins. Note that this bit is pre-set HIGH to enable the output when the device is powered-up, and also when the TAP controller is in the "Test-Logic-Reset" state.

**Reserved**

These instructions are not implemented but are reserved for future use. Do not use these instructions.

TAP Controller State Diagram<sup>[26]</sup>

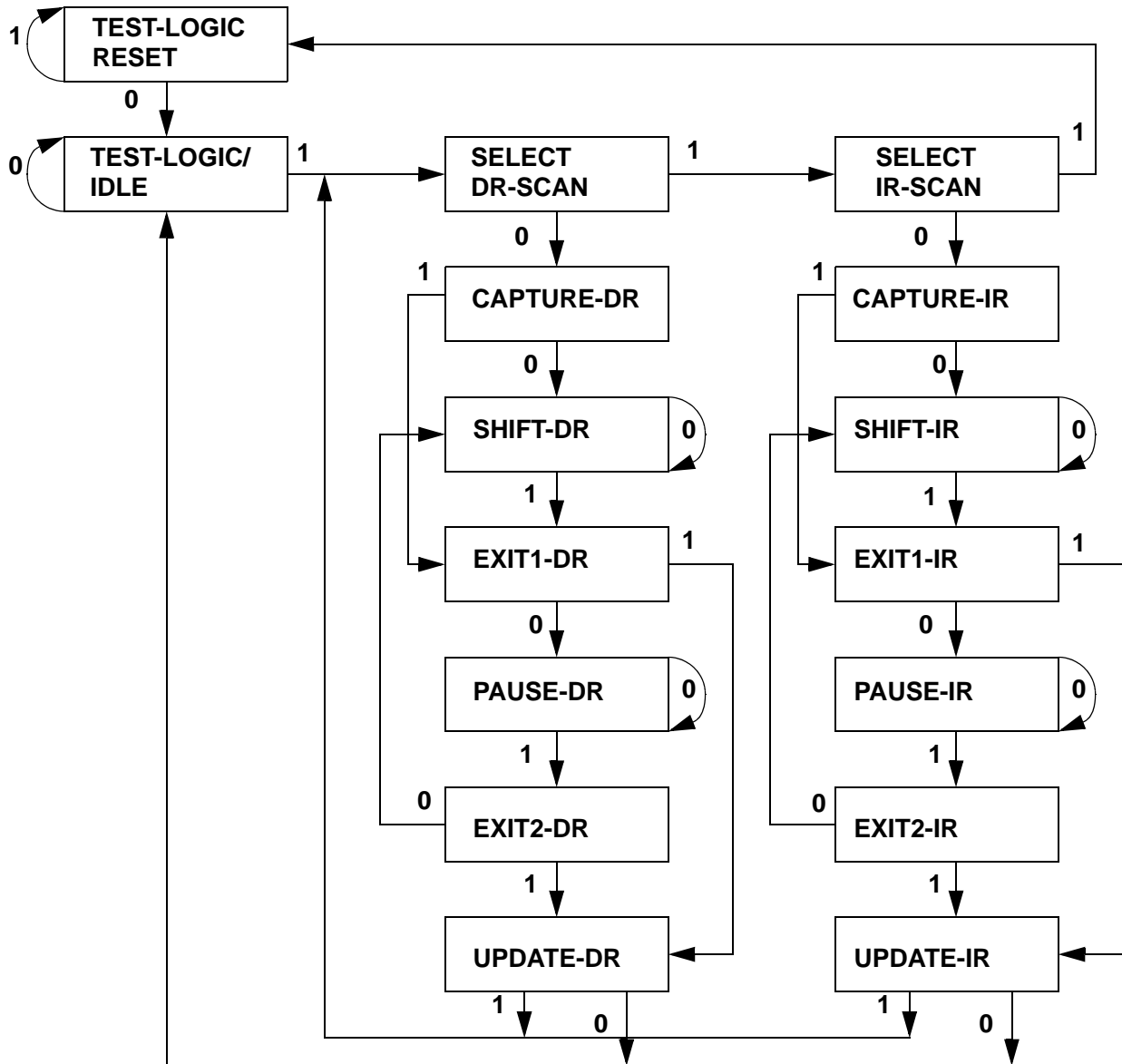

**Note:**  
 26. The 0/1 next to each state represents the value at TMS at the rising edge of TCK.

**TAP Controller Block Diagram**

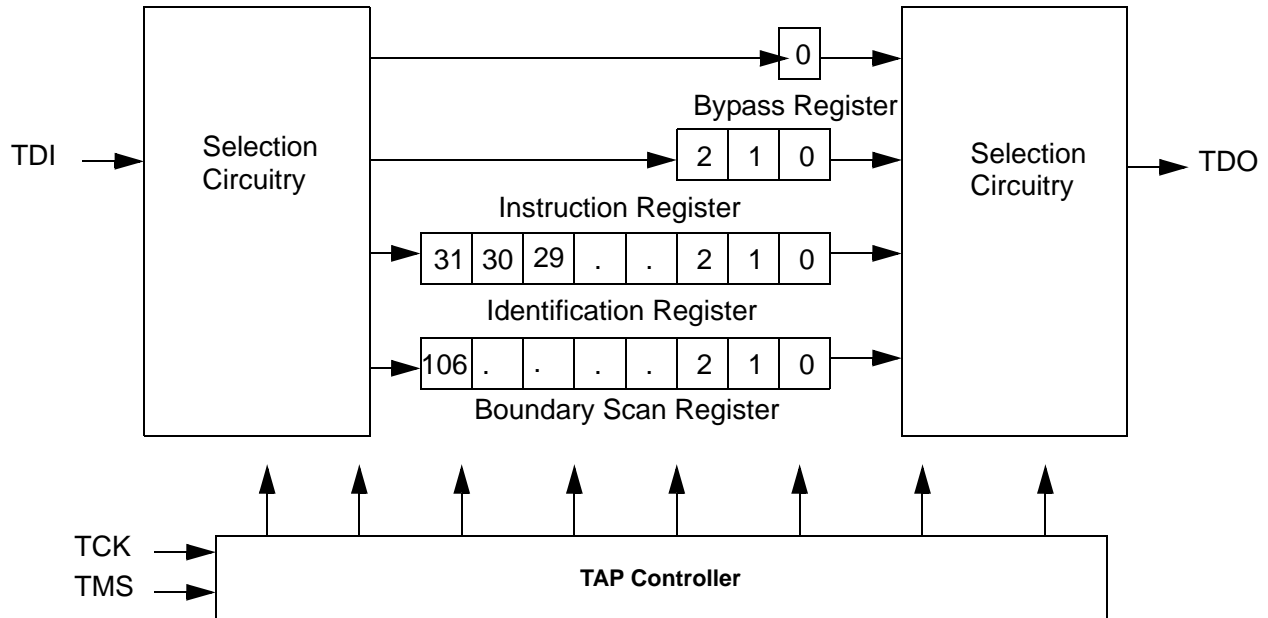

**TAP Electrical Characteristics** Over the Operating Range<sup>[11, 14, 27]</sup>

Parameter	Description	Test Conditions	Min.	Max.	Unit
V <sub>OH1</sub>	Output HIGH Voltage	I <sub>OH</sub> = -2.0 mA	1.4		V
V <sub>OH2</sub>	Output HIGH Voltage	I <sub>OH</sub> = -100 μA	1.6		V
V <sub>OL1</sub>	Output LOW Voltage	I <sub>OL</sub> = 2.0 mA		0.4	V
V <sub>OL2</sub>	Output LOW Voltage	I <sub>OL</sub> = 100 μA		0.2	V
V <sub>IH</sub>	Input HIGH Voltage		0.65V <sub>DD</sub>	V <sub>DD</sub> + 0.3	V
V <sub>IL</sub>	Input LOW Voltage		-0.3	0.35V <sub>DD</sub>	V
I <sub>X</sub>	Input and Output Load Current	GND ≤ V <sub>I</sub> ≤ V <sub>DD</sub>	-5	5	μA

**TAP AC Switching Characteristics** Over the Operating Range<sup>[28, 29]</sup>

Parameter	Description	Min.	Max.	Unit
t <sub>TCYC</sub>	TCK Clock Cycle Time	50		ns
t <sub>TF</sub>	TCK Clock Frequency		20	MHz
t <sub>TH</sub>	TCK Clock HIGH	40		ns
t <sub>TL</sub>	TCK Clock LOW	40		ns
<b>Set-up Times</b>				
t <sub>TMSS</sub>	TMS Set-up to TCK Clock Rise	10		ns
t <sub>TDIS</sub>	TDI Set-up to TCK Clock Rise	10		ns
t <sub>CS</sub>	Capture Set-up to TCK Rise	10		ns
<b>Hold Times</b>				
t <sub>TMSH</sub>	TMS Hold after TCK Clock Rise	10		ns
t <sub>TDIH</sub>	TDI Hold after Clock Rise	10		ns
t <sub>CH</sub>	Capture Hold after Clock Rise	10		ns

**Notes:**

27. These characteristic pertain to the TAP inputs (TMS, TCK, TDI and TDO). Parallel load levels are specified in the Electrical Characteristics Table.

28. t<sub>CS</sub> and t<sub>CH</sub> refer to the set-up and hold time requirements of latching data from the boundary scan register.

29. Test conditions are specified using the load in TAP AC test conditions. t<sub>r</sub>/t<sub>f</sub> = 1 ns.

**TAP AC Switching Characteristics** Over the Operating Range [28, 29] (continued)

Parameter	Description	Min.	Max.	Unit
<b>Output Times</b>				
$t_{TDOV}$	TCK Clock LOW to TDO Valid		20	ns
$t_{TDOX}$	TCK Clock LOW to TDO Invalid	0		ns

**TAP Timing and Test Conditions**[29]

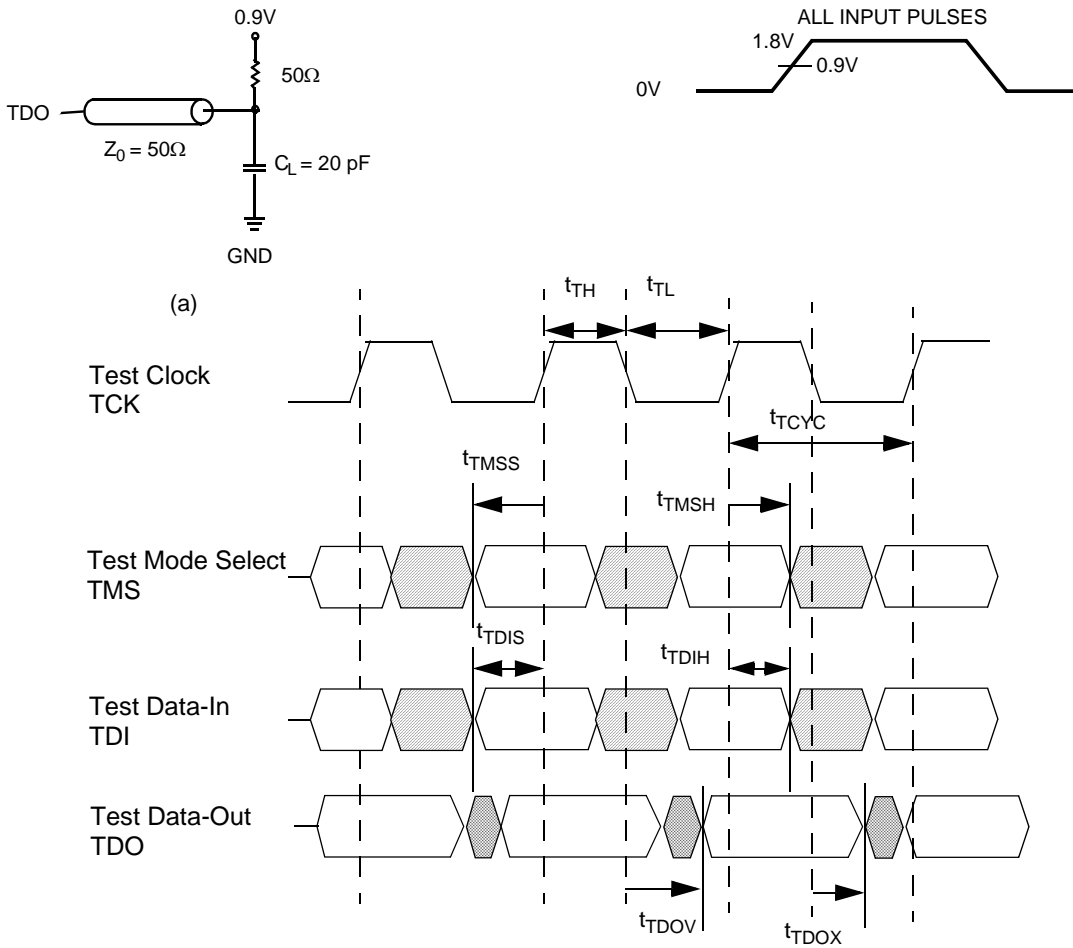

**Identification Register Definitions**

Instruction Field	Value				Description
	CY7C1411V18	CY7C1426V18	CY7C1413V18	CY7C1415V18	
Revision Number (31:29)	000	000	000	000	Version number.
Cypress Device ID (28:12)	11010011011000111	11010011011000111	11010011011010111	11010011011100111	Defines the type of SRAM.
Cypress JEDEC ID (11:1)	00000110100	00000110100	00000110100	00000110100	Allows unique identification of SRAM vendor.
ID Register Presence (0)	1	1	1	1	Indicates the presence of an ID register.



**Scan Register Sizes**

Register Name	Bit Size
Instruction	3
Bypass	1
ID	32
Boundary Scan	109

**Instruction Codes**

Instruction	Code	Description
EXTEST	000	Captures the Input/Output ring contents.
IDCODE	001	Loads the ID register with the vendor ID code and places the register between TDI and TDO. This operation does not affect SRAM operation.
SAMPLE Z	010	Captures the Input/Output contents. Places the boundary scan register between TDI and TDO. Forces all SRAM output drivers to a High-Z state.
RESERVED	011	Do Not Use: This instruction is reserved for future use.
SAMPLE/PRELOAD	100	Captures the Input/Output ring contents. Places the boundary scan register between TDI and TDO. Does not affect the SRAM operation.
RESERVED	101	Do Not Use: This instruction is reserved for future use.
RESERVED	110	Do Not Use: This instruction is reserved for future use.
BYPASS	111	Places the bypass register between TDI and TDO. This operation does not affect SRAM operation.

**Boundary Scan Order**

Bit #	Bump ID
0	6R
1	6P
2	6N
3	7P
4	7N
5	7R
6	8R
7	8P
8	9R
9	11P
10	10P
11	10N
12	9P
13	10M
14	11N
15	9M
16	9N
17	11L
18	11M
19	9L
20	10L
21	11K
22	10K

**Boundary Scan Order** (continued)

Bit #	Bump ID
23	9J
24	9K
25	10J
26	11J
27	11H
28	10G
29	9G
30	11F
31	11G
32	9F
33	10F
34	11E
35	10E
36	10D
37	9E
38	10C
39	11D
40	9C
41	9D
42	11B
43	11C
44	9B
45	10B



**PRELIMINARY**

**CY7C1411V18  
CY7C1426V18  
CY7C1413V18  
CY7C1415V18**

**Boundary Scan Order** (continued)

Bit #	Bump ID
46	11A
47	10A
48	9A
49	8B
50	7C
51	6C
52	8A
53	7A
54	7B
55	6B
56	6A
57	5B
58	5A
59	4A
60	5C
61	4B
62	3A
63	2A
64	1A
65	2B
66	3B
67	1C
68	1B
69	3D
70	3C
71	1D
72	2C
73	3E
74	2D
75	2E
76	1E
77	2F
78	3F
79	1G
80	1F
81	3G
82	2G
83	1H
84	1J
85	2J
86	3K
87	3J
88	2K
89	1K

**Boundary Scan Order** (continued)

Bit #	Bump ID
90	2L
91	3L
92	1M
93	1L
94	3N
95	3M
96	1N
97	2M
98	3P
99	2N
100	2P
101	1P
102	3R
103	4R
104	4P
105	5P
106	5N
107	5R
108	Internal

**Ordering Information**

Speed (MHz)	Ordering Code	Package Name	Package Type	Operating Range
250	CY7C1411V18-250BZC	BB165E	15 x 17 x 1.4 mm FBGA	Commercial
	CY7C1426V18-250BZC			
	CY7C1413V18-250BZC			
	CY7C1415V18-250BZC			
200	CY7C1411V18-200BZC	BB165E	15 x 17x 1.4 mm FBGA	Commercial
	CY7C1426V18-200BZC			
	CY7C1413V18-200BZC			
	CY7C1415V18-200BZC			
167	CY7C1411V18-167BZC	BB165E	15 x 17 x 1.4 mm FBGA	Commercial
	CY7C1426V18-167BZC			
	CY7C1413V18-167BZC			
	CY7C1415V18-167BZC			

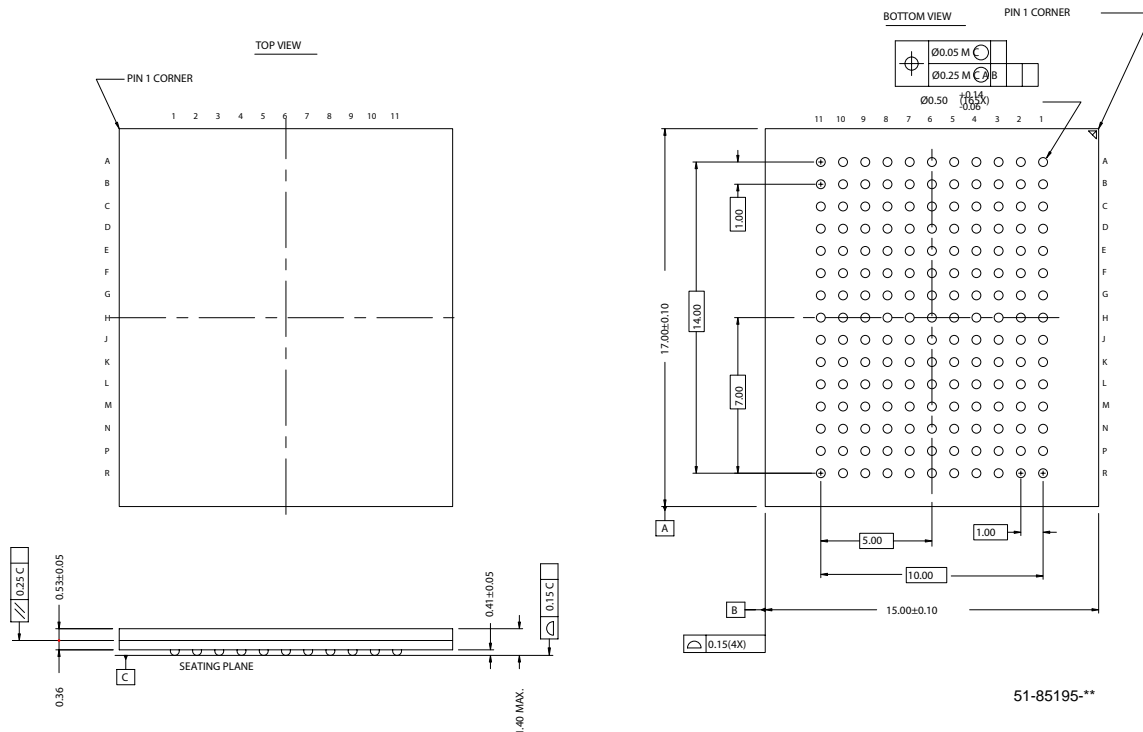
**Package Diagram**
**165-Ball FBGA (15 x 17 x 1.40 mm) Pkg. Outline (0.50 Ball Dia.) BB165E**

51-85195-\*\*

QDR RAMs and Quad Data Rate RAMs comprise a new family of products developed by Cypress, Hitachi, IDT, NEC, and Samsung technology. All product and company names mentioned in this document are the trademarks of their respective holders.



**PRELIMINARY**

CY7C1411V18  
CY7C1426V18  
CY7C1413V18  
CY7C1415V18

**Document History Page**

<b>Document Title: CY7C1411V18/CY7C1426V18/CY7C1413V18/CY7C1415V18 36-Mbit QDR™-II SRAM 4-Word Burst Architecture</b> <b>Document Number: 38-05591</b>				
<b>REV.</b>	<b>ECN NO.</b>	<b>ISSUE DATE</b>	<b>ORIG. OF CHANGE</b>	<b>DESCRIPTION OF CHANGE</b>
**	236629	See ECN	SYT	New Data Sheet