

**2N3741A**

**APPLICATIONS:**

- Drivers
- Switches
- Medium-Power Amplifiers

**FEATURES:**

- Low Saturation Voltage: 0.6 V<sub>CE(sat)</sub> @ I<sub>C</sub> = 1.0 Amp
- High Gain Characteristics: hFE @ I<sub>C</sub> = 250 mA: 30-100
- Excellent Safe Area Limits
- Low Collector Cutoff Current: 100 nA (Max) 2N3741A

**Medium Power  
PNP Transistors**

**DESCRIPTION:**

These power transistors are produced by PPC's DOUBLE DIFFUSED PLANAR process. This technology produces high voltage devices with excellent switching speeds, frequency response, gain linearity, saturation voltages, high current gain, and safe operating areas. They are intended for use in Commercial, Industrial, and Military power switching, amplifier, and regulator applications.

Ultrasonically bonded leads and controlled die mount techniques are utilized to further increase the SOA capability and inherent reliability of these devices. The temperature range to 200°C permits reliable operation in high ambients, and the hermetically sealed package insures maximum reliability and long life.

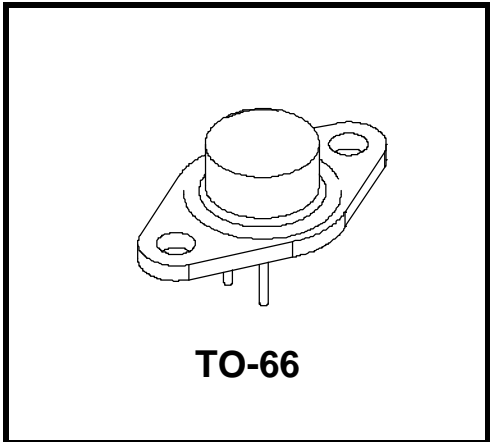

**ABSOLUTE MAXIMUM RATINGS:**

SYMBOL	CHARACTERISTIC	VALUE	UNITS
V <sub>CEO</sub> *	Collector-Emitter Voltage	80	Vdc
V <sub>EB</sub> *	Emitter-Base Voltage	7.0	Vdc
V <sub>CB</sub> *	Collector-Base Voltage	80	Vdc
I <sub>C</sub> *	Peak Collector Current	10	Adc
I <sub>C</sub> *	Continuous Collector Current	4.0	Adc
I <sub>B</sub> *	Base Current	2.0	Adc
T <sub>STG</sub> *	Storage Temperature	-65 to 200	°C
T <sub>J</sub> *	Operating Junction Temperature	-65 to 200	°C
P <sub>D</sub> *	Total Device Dissipation	25	Watts
	T <sub>C</sub> = 25°C		
	Derate above 25°C	0.143	W/°C
θ <sub>JC</sub>	Thermal Impedance	7	°C/W

\* Indicates JEDEC registered data.

**ELECTRICAL CHARACTERISTICS:  
 (25° Case Temperature Unless Otherwise Noted)**

SYMBOL	CHARACTERISTIC	TEST CONDITIONS	VALUE		Units
			Min.	Max.	
V <sub>CE(sus)</sub> *	Collector-Emitter Sustaining Voltage	I <sub>C</sub> = 100 mAdc, I <sub>B</sub> = 0 (Note 1)	80	----	Vdc
I <sub>EB0</sub> *	Emitter Base Cutoff Current	V <sub>EB</sub> = 7.0 Vdc	----	100	nAdc
I <sub>CEx</sub> *	Collector Cutoff Current	V <sub>CE</sub> = 80 Vdc, V <sub>BE(off)</sub> = 1.5 Vdc V <sub>CE</sub> = 60 Vdc, V <sub>BE(off)</sub> = 1.5 Vdc, T <sub>C</sub> = 150°C	----	100 0.5	nAdc mAdc
I <sub>CEO</sub> *	Collector-Emitter Cutoff Current	V <sub>CE</sub> = 60 Vdc, I <sub>B</sub> = 0	----	1.0	μAdc
I <sub>CBO</sub> *	Collector Base Cutoff Current	V <sub>CB</sub> = 80 Vdc, I <sub>E</sub> = 0	----	100	nAdc
h <sub>FE</sub> *	DC Current Gain (Note 1)	I <sub>C</sub> = 100 mAdc, V <sub>CE</sub> = 1.0 Vdc I <sub>C</sub> = 250 mAdc, V <sub>CE</sub> = 1.0 Vdc I <sub>C</sub> = 500 mAdc, V <sub>CE</sub> = 1.0 Vdc I <sub>C</sub> = 1.0 Adc, V <sub>CE</sub> = 1.0 Vdc	40 30 20 10	---- 100 ---- ----	---- ---- ---- ----
V <sub>CE(sat)</sub> *	Collector-Emitter Saturation Voltage (Note 1)	I <sub>C</sub> = 1.0 Adc, I <sub>B</sub> = 125 mAdc	----	0.6	Vdc
V <sub>BE</sub> *	Base-Emitter Voltage (Note 1)	I <sub>C</sub> = 250 mAdc, V <sub>CE</sub> = 1.0 Vdc	----	1.0	Vdc
f <sub>T</sub> *	Current Gain Bandwidth Product	I <sub>C</sub> = 100 mAdc, V <sub>CE</sub> = 10 Vdc, f = 1.0 MHz	3.0	----	MHz
h <sub>fe</sub> *	Small-Signal Current Gain	I <sub>C</sub> = 50 mAdc, V <sub>CE</sub> = 10 Vdc, f = 1.0 kHz	25	----	----
C <sub>ob</sub> *	Common Base Output Capacitance	V <sub>CB</sub> = 10 Vdc, I <sub>C</sub> = 0, f = 100 kHz	----	100	pF

Note 1: Pulse Test: PW ≤ 300μs, Duty Cycle ≤ 2.0%

\* Indicates JEDEC registered data.

2N3741A

**PACKAGE MECHANICAL DATA:**

