

## DUAL HIGH SPEED DRIVER

### DESCRIPTION

The SG1626, 2626, 3626 is a dual inverting monolithic high speed driver that is pin for pin compatible with the DS0026, TSC426 and ICL7667. This device utilizes high voltage Schottky logic to convert TTL signals to high speed outputs up to 18V. The totem pole outputs have 3A peak current capability, which enables them to drive 1000pF loads in typically less than 25ns. These speeds make it ideal for driving power MOSFETs and other large capacitive loads requiring high speed switching.

In addition to the standard packages, Silicon General offers the 16 pin S.O.I.C. (DW-package) for commercial and industrial applications, and the Hermetic TO-66 (R-package) for military use. These packages offer improved thermal performance for applications requiring high frequencies and/or high peak currents.

### FEATURES

- Pin for pin compatible with DS0026, TSC426 and ICL7667.
- Totem pole outputs with 3.0A peak current capability.
- Supply voltage to 22V.
- Rise and fall times less than 25ns.
- Propagation delays less than 20ns.
- Inverting high-speed high-voltage Schottky logic.
- Efficient operation at high frequency.
- Available in:
  - 8 Pin Plastic and Ceramic DIP
  - 14 Pin Ceramic DIP
  - 16 Pin Plastic S.O.I.C.
  - 20 Pin LCC
  - TO-99
  - TO-66

### HIGH RELIABILITY FEATURES - SG1626

- ◆ Available to MIL-STD-883
- ◆ Radiation data available
- ◆ LMI level "S" processing available

### EQUIVALENT CIRCUIT SCHEMATIC

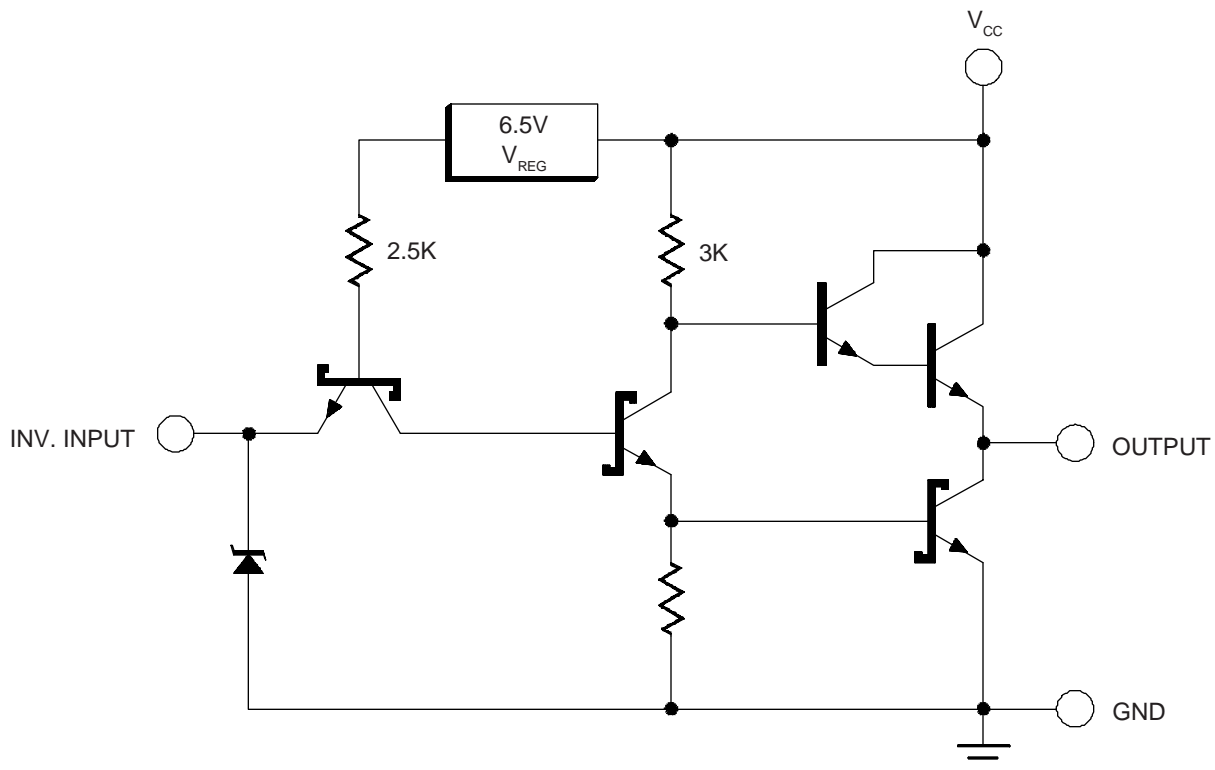

## ABSOLUTE MAXIMUM RATINGS (Note 1)

Supply Voltage ( $V_{CC}$ ) .....	22V	Operating Junction Temperature	
Logic Input Voltage .....	7V	Hermetic (J, T, Y, R-Packages) .....	150°C
Source/Sink Output Current (Each Output)		Plastic (M, DW, L-Packages) .....	150°C
Continuous .....	±0.5A	Storage Temperature Range .....	-65°C to 150°C
Pulse, 500ns .....	±3.0A	Lead Temperature (Soldering, 10 Seconds) .....	300°C

Note 1. Exceeding these ratings could cause damage to the device. All voltages are with respect to ground. All currents are positive into the specified terminal.

## THERMAL DATA

J Package:

Thermal Resistance-Junction to Case, $\theta_{JC}$ .....	30°C/W
Thermal Resistance-Junction to Ambient, $\theta_{JA}$ .....	80°C/W

Y Package:

Thermal Resistance-Junction to Case, $\theta_{JC}$ .....	50°C/W
Thermal Resistance-Junction to Ambient, $\theta_{JA}$ .....	130°C/W

M Package:

Thermal Resistance-Junction to Case, $\theta_{JC}$ .....	60°C/W
Thermal Resistance-Junction to Ambient, $\theta_{JA}$ .....	95°C/W

DW Package:

Thermal Resistance-Junction to Case, $\theta_{JC}$ .....	40°C/W
Thermal Resistance-Junction to Ambient, $\theta_{JA}$ .....	95°C/W

T Package:

Thermal Resistance-Junction to Case, $\theta_{JC}$ .....	25°C/W
Thermal Resistance-Junction to Ambient, $\theta_{JA}$ .....	130°C/W

R Package:

Thermal Resistance-Junction to Case, $\theta_{JC}$ .....	5.0°C/W
Thermal Resistance-Junction to Ambient, $\theta_{JA}$ .....	40°C/W

L Package:

Thermal Resistance-Junction to Case, $\theta_{JC}$ .....	35°C/W
Thermal Resistance-Junction to Ambient, $\theta_{JA}$ .....	120°C/W

Note A. Junction Temperature Calculation:  $T_J = T_A + (P_D \times \theta_{JA})$ .

Note B. The above numbers for  $\theta_{JC}$  are maximums for the limiting thermal resistance of the package in a standard mounting configuration. The  $\theta_{JA}$  numbers are meant to be guidelines for the thermal performance of the device/pc-board system. All of the above assume no ambient airflow.

## RECOMMENDED OPERATING CONDITIONS (Note 2)

Supply Voltage ( $V_{CC}$ ) .....	4.5V to 20V (Note 3)	Operating Ambient Temperature Range ( $T_A$ )	
Frequency Range .....	DC to 1.5MHz	SG1626 .....	-55°C to 125°C
Peak Pulse Current .....	±3A	SG2626 .....	-25°C to 85°C
Logic Input Voltage .....	-0.5 to 5.5V	SG3626 .....	0°C to 70°C

Note 2. Range over which the device is functional.

Note 3. AC performance has been optimized for  $V_{CC} = 8V$  to 20V.

## ELECTRICAL CHARACTERISTICS

(Unless otherwise specified, these specifications apply over the operating ambient temperatures for SG1626 with  $-55^\circ\text{C} \leq T_A \leq 125^\circ\text{C}$ , SG2626 with  $-25^\circ\text{C} \leq T_A \leq 85^\circ\text{C}$ , SG3626 with  $0^\circ\text{C} \leq T_A \leq 70^\circ\text{C}$ , and  $V_{CC} = 20V$ . Low duty cycle pulse testing techniques are used which maintains junction and case temperatures equal to the ambient temperature.)

Parameter	Test Conditions	SG1626/2626/3626			Units
		Min.	Typ.	Max.	
<b>Static Characteristics</b>					
Logic 1 Input Voltage		2.0			V
Logic 0 Input Voltage				0.7	V
Input High Current	$V_{IN} = 2.4V$			500	µA
Input High Current	$V_{IN} = 5.5V$			1.0	mA
Input Low Current	$V_{IN} = 0V$			-4	mA
Input Clamp Voltage	$I_{IN} = -10mA$			-1.5	V
Output High Voltage (Note 4)	$I_{OUT} = -200mA$	$V_{CC}-3$			V
Output Low Voltage (Note 4)	$I_{OUT} = 200mA$			1.0	V
Supply Current Outputs Low	$V_{IN} = 2.4V$ (both inputs)		18	27	mA
Supply Current Outputs High	$V_{IN} = 0V$ (both inputs)		7.5	12	mA

Note 4.  $V_{CC} = 10V$  to 20V.

## ELECTRICAL CHARACTERISTICS (continued)

Parameter	Test Conditions (Figure 1)	SG1626/2626/3626 T <sub>A</sub> = 25°C			SG1626 T <sub>A</sub> = -55°C to 125°C			Units
		Min.	Typ.	Max.	Min.	Typ.	Max.	
<b>Dynamic Characteristics</b> (Note 6)								
Propagation Delay High-Low (TPHL)	C <sub>L</sub> = 1000pF (Note 5)			18			30	ns
	C <sub>L</sub> = 2500pF		17	25			40	ns
Propagation Delay Low-High (TPLH)	C <sub>L</sub> = 1000pF (Note 5)			25			40	ns
	C <sub>L</sub> = 2500pF		25	35			50	ns
Rise Time (TTLH)	C <sub>L</sub> = 1000pF (Note 5)			30			35	ns
	C <sub>L</sub> = 2500pF		30	40			50	ns
Fall Time (TTHL)	C <sub>L</sub> = 1000pF (Note 5)			20			30	ns
	C <sub>L</sub> = 2500pF		30	40			50	ns
Supply Current (I <sub>CC</sub> ) (both outputs)	C <sub>L</sub> = 2500pF, Freq. = 200KHz Duty Cycle = 50%		30	35			40	mA

Note 5. These parameters, specified at 1000pF, although guaranteed over recommended operating conditions, are not 100% tested in production.

Note 6. V<sub>CC</sub> = 15V.

## AC TEST CIRCUIT AND SWITCHING TIME WAVEFORMS - FIGURE 1

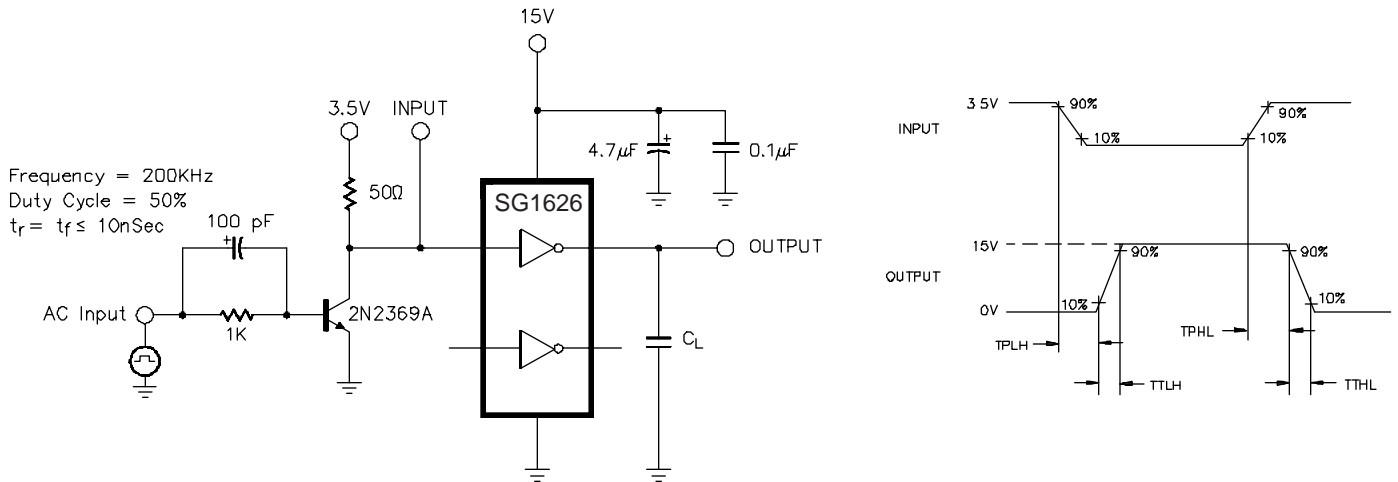

## CHARACTERISTIC CURVES

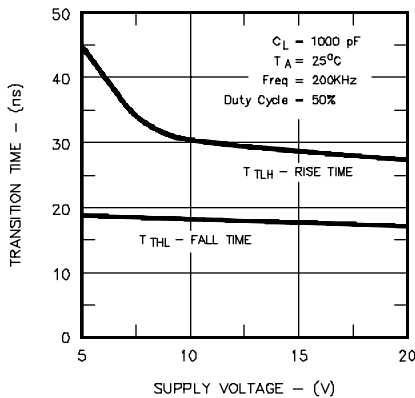

FIGURE 2. TRANSITION TIMES VS. SUPPLY VOLTAGE

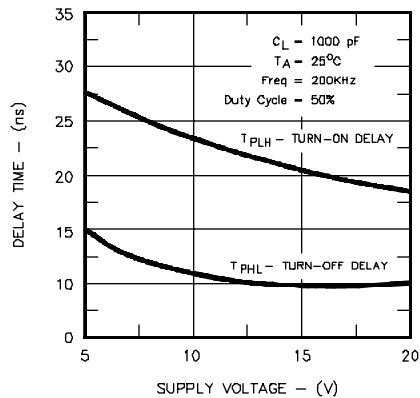

FIGURE 3. PROPAGATION DELAY VS. SUPPLY VOLTAGE

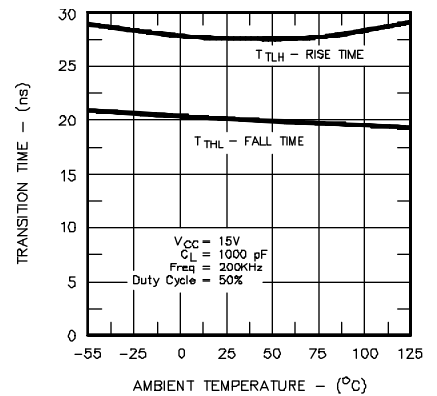

FIGURE 4. TRANSITION TIMES VS. AMBIENT TEMPERATURE

CHARACTERISTIC CURVES (continued)

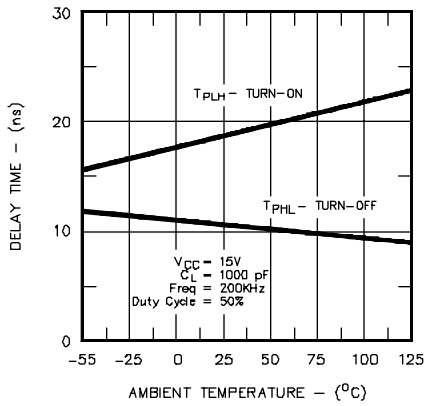

FIGURE 5. PROPAGATION DELAY VS. AMBIENT TEMPERATURE

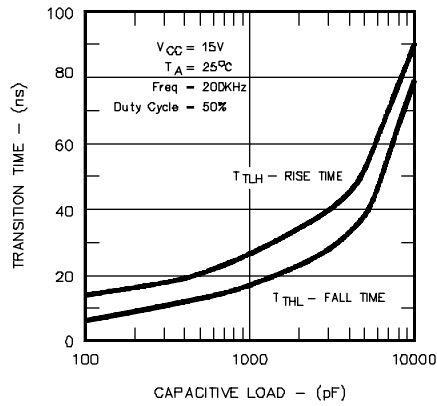

FIGURE 6. TRANSITION TIMES VS. CAPACITIVE LOAD

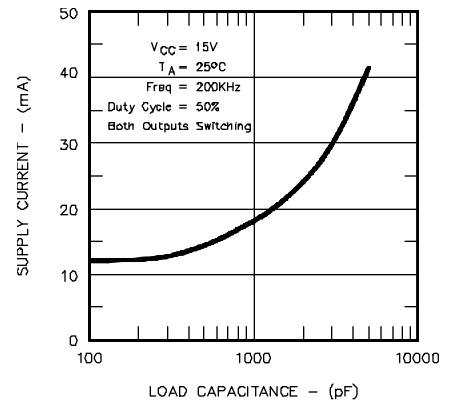

FIGURE 7. SUPPLY CURRENT VS. CAPACITANCE LOAD

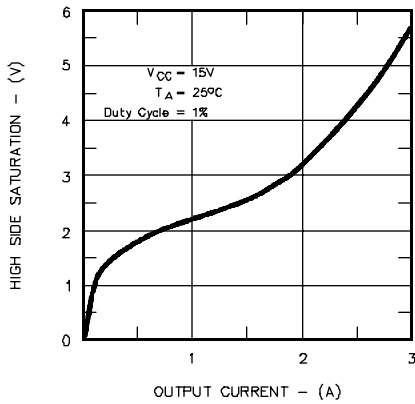

FIGURE 8. HIGH SIDE SATURATION VS. OUTPUT CURRENT

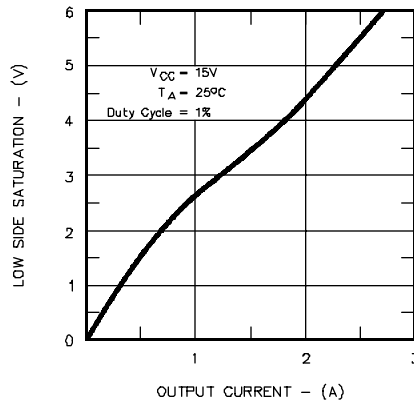

FIGURE 9. LOW SIDE SATURATION VS. OUTPUT CURRENT

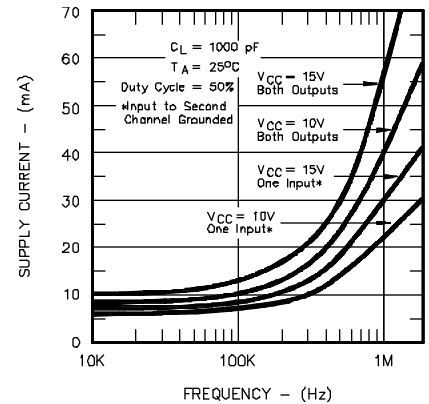

FIGURE 10. SUPPLY CURRENT VS. FREQUENCY

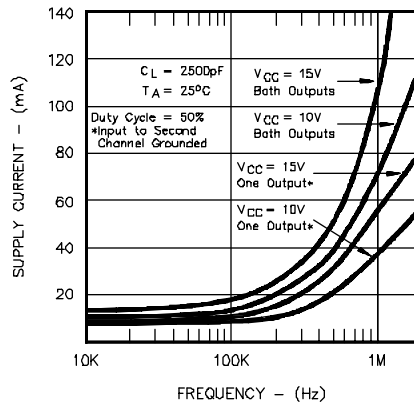

FIGURE 11. SUPPLY CURRENT VS. FREQUENCY

## APPLICATION INFORMATION

### POWER DISSIPATION

The SG1626, while more energy-efficient than earlier gold-doped driver IC's, can still dissipate considerable power because of its high peak current capability at high frequencies. Total power dissipation in any specific application will be the sum of the DC or steady-state power dissipation, and the AC dissipation caused by driving capacitive loads.

The DC power dissipation is given by:

$$P_{DC} = +V_{CC} \cdot I_{CC} \quad [1]$$

where  $I_{CC}$  is a function of the driver state, and hence is duty-cycle dependent.

The AC power dissipation is proportional to the switching frequency, the load capacitance, and the square of the output voltage. In most applications, the driver is constantly changing state, and the AC contribution becomes dominant when the frequency exceeds 100-200KHz.

The SG1626 driver family is available in a variety of packages to accommodate a wide range of operating temperatures and power dissipation requirements. The Absolute Maximums section of the data sheet includes two graphs to aid the designer in choosing an appropriate package for his design.

The designer should first determine the actual power dissipation of the driver by referring to the curves in the data sheet relating operating current to supply voltage, switching frequency, and capacitive load. These curves were generated from data taken on actual devices. The designer can then refer to the Absolute Maximum Thermal Dissipation curves to choose a package type, and to determine if heat-sinking is required.

### DESIGN EXAMPLE

Given: Two 2500 pF loads must be driven push-pull from a +15 volt supply at 100KHz. This is a commercial application where the maximum ambient temperature is +50°C, and cost is important.

1. From Figure 11, the average driver current consumption under these conditions will be 18mA, and the power dissipation will be 15volts x 18mA, or 270mW.

2. From the Ambient Thermal Characteristic curve, it can be seen that the M package, which is an 8-pin plastic DIP with a copper lead frame, has more than enough thermal conductance from junction to ambient to support operation at an ambient temperature of +50°C. The SG3626M driver would be specified for this application.

### SUPPLY BYPASSING

Since the SG1626 can deliver peak currents above 3amps under some load conditions, adequate supply bypassing is essential for proper operation. Two capacitors in parallel are recommended to guarantee low supply impedance over a wide bandwidth: a 0.1µF ceramic disk capacitor for high frequencies, and a 4.7µF solid tantalum capacitor for energy storage. In military applica-

tions, a CK05 or CK06 ceramic operator with a CSR-13 tantalum capacitor is an effective combination. For commercial applications, any low-inductance ceramic disk capacitor teamed with a Sprague 150D or equivalent low ESR capacitor will work well. The capacitors must be located as close as physically possible to the  $V_{CC}$  pin, with combined lead and pc board trace lengths held to less than 0.5 inches.

### GROUNDING CONSIDERATIONS

Since ground is both the reference potential for the driver logic and the return path for the high peak output currents of the driver, use of a low-inductance ground system is essential. A ground plane is highly recommended for best performance. In dense, high performance applications a 4-layer pc board works best; the 2 inner planes are dedicated to power and ground distribution, and signal traces are carried by the outside layers. For cost-sensitive designs a 2-layer board can be made to work, with one layer dedicated completely to ground, and the other to power and signal distribution. A great deal of attention to component layout and interconnect routing is required for this approach.

### LOGIC INTERFACE

The logic input of the 1626 is designed to accept standard DC-coupled 5 volt logic swings, with no speed-up capacitors required. If the input signal voltage exceeds 6 volts, the input pin must be protected against the excessive voltage in the HIGH state. Either a high speed blocking diode must be used, or a resistive divider to attenuate the logic swing is necessary.

### LAYOUT FOR HIGH SPEED

The SG1626 can generate relatively large voltage excursions with rise and fall times around 20-30 nanoseconds with light capacitive loads. A Fourier analysis of these time domain signals will indicate strong energy components at frequencies much higher than the basic switching frequency. These high frequencies can induce ringing on an otherwise ideal pulse if sufficient inductance occurs in the signal path (either the positive signal trace or the ground return). Overshoot on the rising edge is undesirable because the excess drive voltage could rupture the gate oxide of a power MOSFET. Trailing edge undershoot is dangerous because the negative voltage excursion can forward-bias the parasitic PN substrate diode of the driver, potentially causing erratic operation or outright failure.

Ringing can be reduced or eliminated by minimizing signal path inductance, and by using a damping resistor between the drive output and the capacitive load. Inductance can be reduced by keeping trace lengths short, trace widths wide, and by using 2oz. copper if possible. The resistor value for critical damping can be calculated from:

$$R_D = 2\sqrt{L/C_L} \quad [2]$$

where L is the total signal line inductance, and  $C_L$  is the load capacitance. Values between 10 and 100ohms are usually sufficient. Inexpensive carbon composition resistors are best because they have excellent high frequency characteristics. They should be located as close as possible to the gate terminal of the power MOSFET.

TYPICAL APPLICATIONS

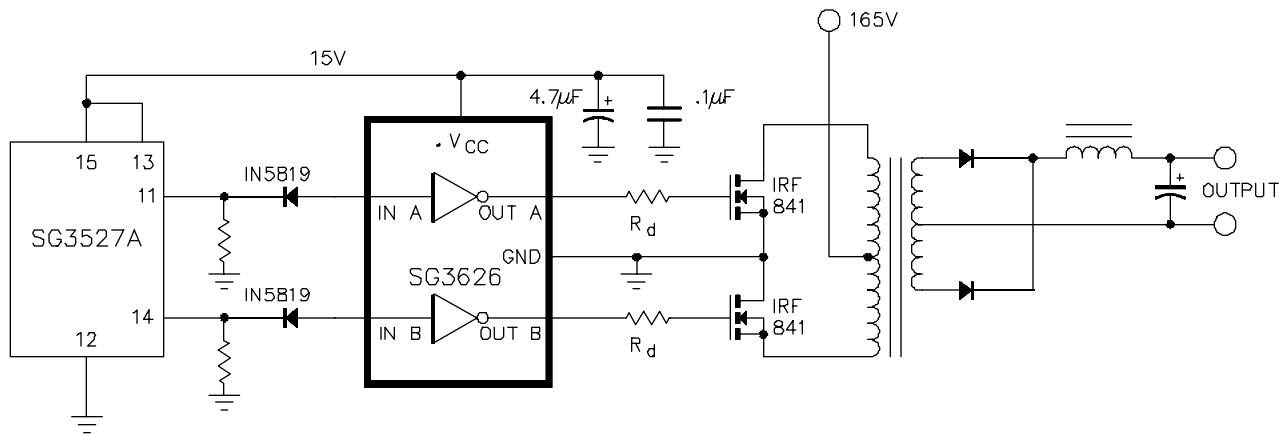

**FIGURE 12.**

When the SG3626 is driven from a totem-pole source with a peak output greater than 6 volts, a low-current, fast-switching blocking diode is required at each logic input for protection. In this push-pull converter, the inverted logic outputs of the 3527A are ideal control sources for the power driver.

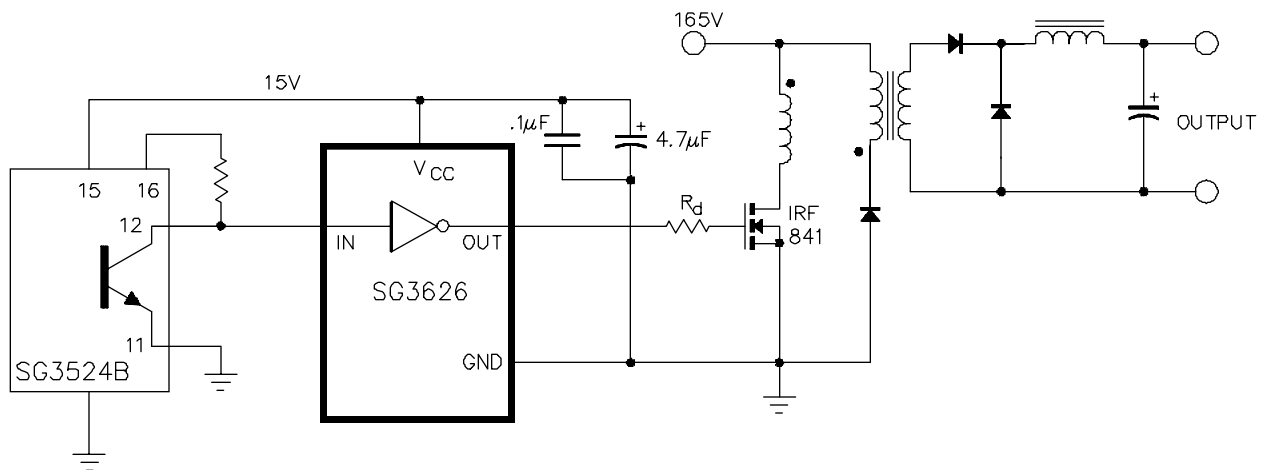

**FIGURE 13.**

In this forward converter circuit, the control capabilities of the SG3524B PWM are combined with the powerful totem-pole drivers found in the SG3626. This inexpensive configuration results in very fast charge and discharge of the power MOSFET gate capacitance for efficient switching.

TYPICAL APPLICATIONS (continued)

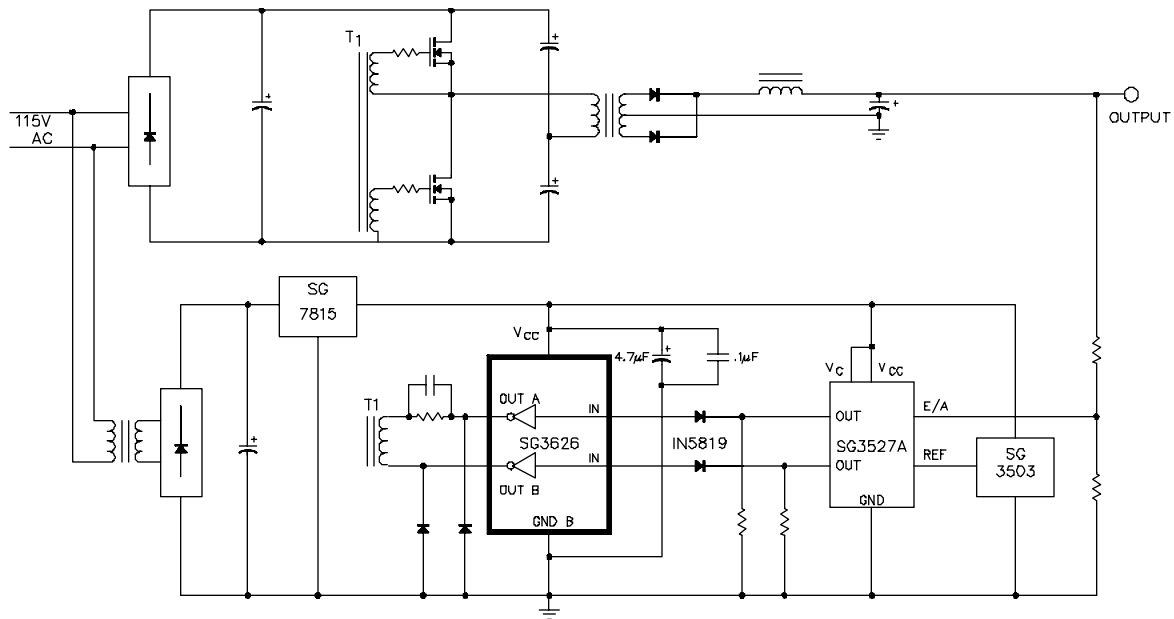

**FIGURE 14.** In half or full-bridge power supplies, driving the isolation transformers directly from the PWM can cause excessive IC temperatures, especially above 100KHz. This circuit uses the high drive capacity of the SG3626 to solve the problem.

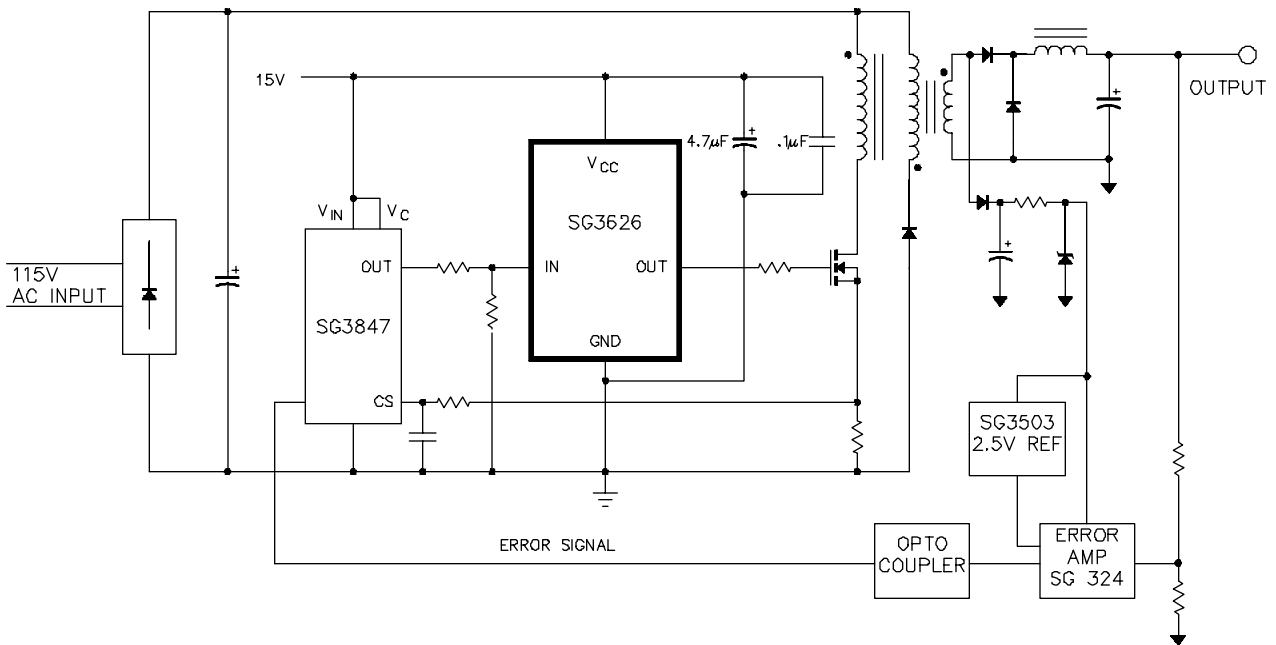

**FIGURE 15.** A low-impedance resistive divider network can also be used as the interface between the PWM high-voltage logic output and the SG3626 power driver. In this 200KHz current mode converter, the SG3847 provides control, while the SG3626 provides high power drive and minimizes ground spiking in the control IC.

## CONNECTION DIAGRAMS & ORDERING INFORMATION (See Notes Below)

Package	Part No.	Ambient Temperature Range	Connection Diagram
14-PIN CERAMIC DIP J - PACKAGE	SG1626J/883B SG1626J/DESC SG1626J SG2626J SG3626J	-55°C to 125°C -55°C to 125°C -55°C to 125°C -25°C to 85°C 0°C to 70°C	
8-PIN CERAMIC DIP Y - PACKAGE	SG1626Y/883B SG1626Y/DESC SG1626Y SG2626Y SG3626Y	-55°C to 125°C -55°C to 125°C -55°C to 125°C -25°C to 85°C 0°C to 70°C	
8-PIN PLASTIC DIP M - PACKAGE	SG2626M SG3626M	-25°C to 85°C 0°C to 70°C	
16-PIN WIDE BODY PLASTIC S.O.I.C. DW - PACKAGE	SG2626DW SG3626DW	-25°C to 85°C 0°C to 70°C	
8-PIN TO-99 METAL CAN T - PACKAGE	SG1626T/883B SG1626T/DESC SG1626T SG2626T SG3626T	-55°C to 125°C -55°C to 125°C -55°C to 125°C -25°C to 85°C 0°C to 70°C	
5-PIN TO-66 METAL CAN R - PACKAGE	SG1626R/883B SG1626R/DESC SG1626R SG2626R SG3626R	-55°C to 125°C -55°C to 125°C -55°C to 125°C -25°C to 85°C 0°C to 70°C	
20-PIN CERAMIC (LCC) LEADLESS CHIP CARRIER L- PACKAGE	SG1626L/883B	-55°C to 125°C	<p>(Note 4)</p>

Note 1. Contact factory for JAN and DESC product availability.  
 Note 2. All packages are viewed from the top.