

# General purpose (dual digital transistors)

## EMH9 / UMH9N / IMH9A

### ●Features

- 1) Two DTC114Ys chips in a EMT or UMT or SMT package.
- 2) Mounting possible with EMT3 or UMT3 or SMT3 automatic mounting machines.
- 3) Transistor elements are independent, eliminating interference.
- 4) Mounting cost and area can be cut in half.

### ●Structure

Epitaxial planar type  
NPN silicon transistor  
(Built-in resistor type)

The following characteristics apply to both DT<sub>r1</sub> and DT<sub>r2</sub>.

### ●Equivalent circuit

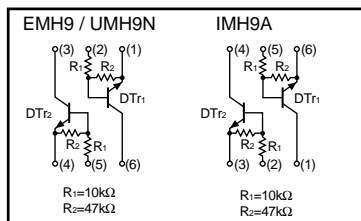

### ●Packaging specifications

Type	Package	Taping		
	Code	T2R	TN	T110
	Basic ordering unit (pieces)	8000	3000	3000
EMH9		○	-	-
UMH9N		-	○	-
IMH9A		-	-	○

### ●External dimensions (Units : mm)

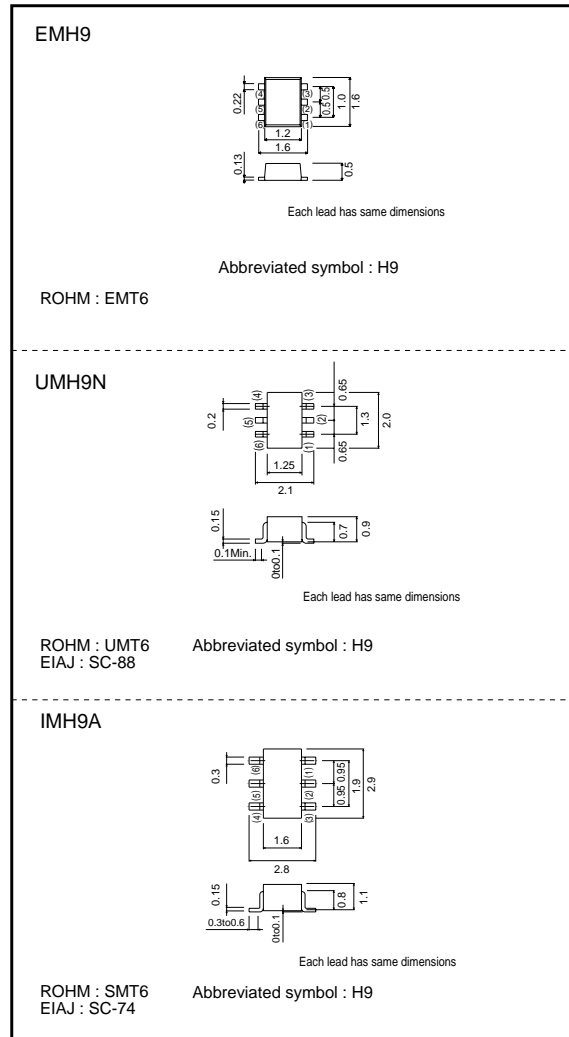

Transistors

●Absolute maximum ratings (Ta = 25°C)

Parameter		Symbol	Limits	Unit
Supply voltage		V <sub>CC</sub>	50	V
Input voltage		V <sub>IN</sub>	40	V
			-6	
Output current		I <sub>O</sub>	70	mA
			I <sub>C (Max.)</sub>	
Power dissipation	EMH9, UMH9N	P <sub>d</sub>	150 (TOTAL)	mW
	IMH9A		300 (TOTAL)	
Junction temperature		T <sub>J</sub>	150	°C
Storage temperature		T <sub>stg</sub>	-55~+150	°C

\*1 120mW per element must not be exceeded.  
 \*2 200mW per element must not be exceeded.

●Electrical characteristics (Ta = 25°C)

Parameter	Symbol	Min.	Typ.	Max.	Unit	Conditions
Input voltage	V <sub>I (off)</sub>	-	-	0.3	V	V <sub>CC</sub> =5V, I <sub>O</sub> =100μA
	V <sub>I (on)</sub>	1.4	-	-		V <sub>O</sub> =0.3V, I <sub>O</sub> =1mA
Output voltage	V <sub>O (on)</sub>	-	0.1	0.3	V	I <sub>O</sub> /I <sub>I</sub> =5mA/0.25mA
Input current	I <sub>I</sub>	-	-	0.88	mA	V <sub>I</sub> =5V
Output current	I <sub>O (off)</sub>	-	-	0.5	μA	V <sub>CC</sub> =50V, V <sub>I</sub> =0V
DC current gain	G <sub>I</sub>	68	-	-	-	V <sub>O</sub> =5V, I <sub>O</sub> =5mA
Transition frequency	f <sub>T</sub>	-	250	-	MHz	V <sub>CE</sub> =10mA, I <sub>E</sub> =-5mA, f=100MHz *
Input resistance	R <sub>1</sub>	7	10	13	kΩ	-
Resistance ratio	R <sub>2</sub> /R <sub>1</sub>	3.7	4.7	5.7	-	-

\* Transition frequency of the device

●Electrical characteristic curves

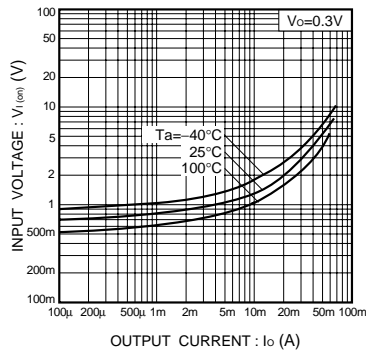

Fig.1 Input voltage vs. output current (ON characteristics)

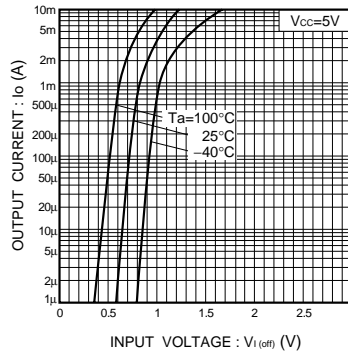

Fig.2 Output current vs. input voltage (OFF characteristics)

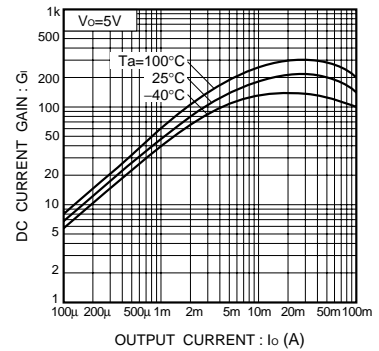

Fig.3 DC current gain vs. output current

Transistors

---

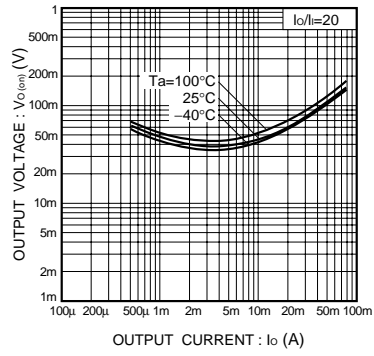

Fig.4 Output voltage vs. output current