

# SHINDENGEN

## Schottky Rectifiers (SBD)

Single

# D3FP3

## 30V 3A

### FEATURES

- Small SMT
- Super low  $V_F=0.4V$

### APPLICATION

- Reversed Battery Connection Protection
- DC OR output
- DC/DC converter
- Mobile telephone, personal computer

### OUTLINE DIMENSIONS

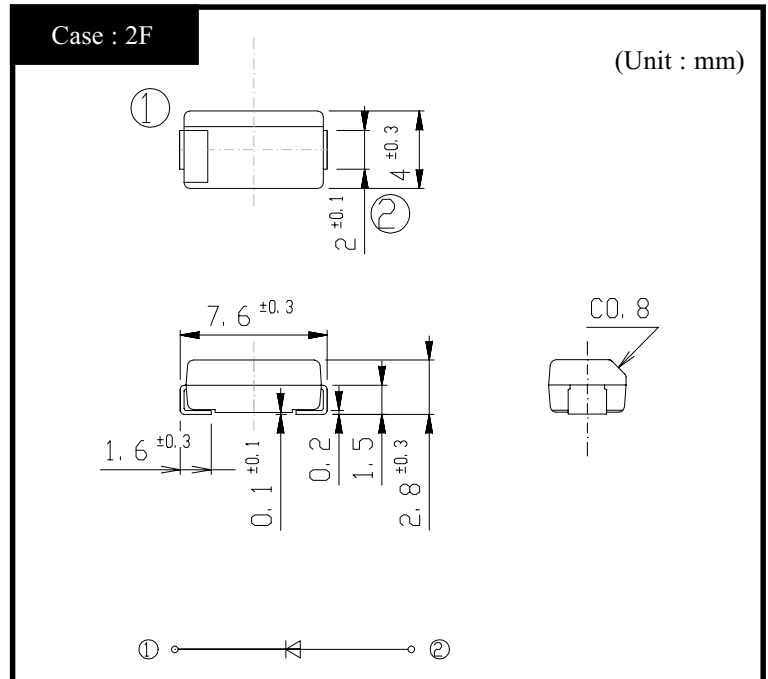

### RATINGS

- Absolute Maximum Ratings (If not specified  $T_I=25^{\circ}C$ )

Item	Symbol	Conditions	Ratings	Unit
Storage Temperature	$T_{stg}$		-55~125	$^{\circ}C$
Operating Junction Temperature	$T_j$		125	$^{\circ}C$
Maximum Reverse Voltage	$V_{RM}$		30	V
Repetitive Peak Surge Reverse Voltage	$V_{RRSM}$	Pulse width 0.5ms, duty 1/40	35	V
Average Rectified Forward Current	$I_O$	50Hz sine wave, R-load $T_I=74^{\circ}C$	3	A
Peak Surge Forward Current	$I_{FSM}$	50Hz sine wave, Non-repetitive 1 cycle peak value, $T_j=25^{\circ}C$	150	A

- Electrical Characteristics (If not specified  $T_I=25^{\circ}C$ )

Item	Symbol	Conditions	Ratings	Unit
Forward Voltage	$V_{F1}$	$I_F=1.6A$ , Pulse measurement	Max.0.35	V
	$V_{F2}$	$I_F=4A$ , Pulse measurement	Max.0.40	V
Reverse Current	$I_R$	$V_R=V_{RM}$ , Pulse measurement	Max.10	mA
Junction Capacitance	$C_j$	$f=1MHz$ , $V_R=10V$	Typ.300	pF
Thermal Resistance	$\theta_{jl}$	junction to lead	Max.24	$^{\circ}C/W$
	$\theta_{ja}$	junction to ambient On alumina substrate	Max.90	
		junction to ambient On glass-epoxy substrate	Max.120	

# D3FP3

## Forward Voltage

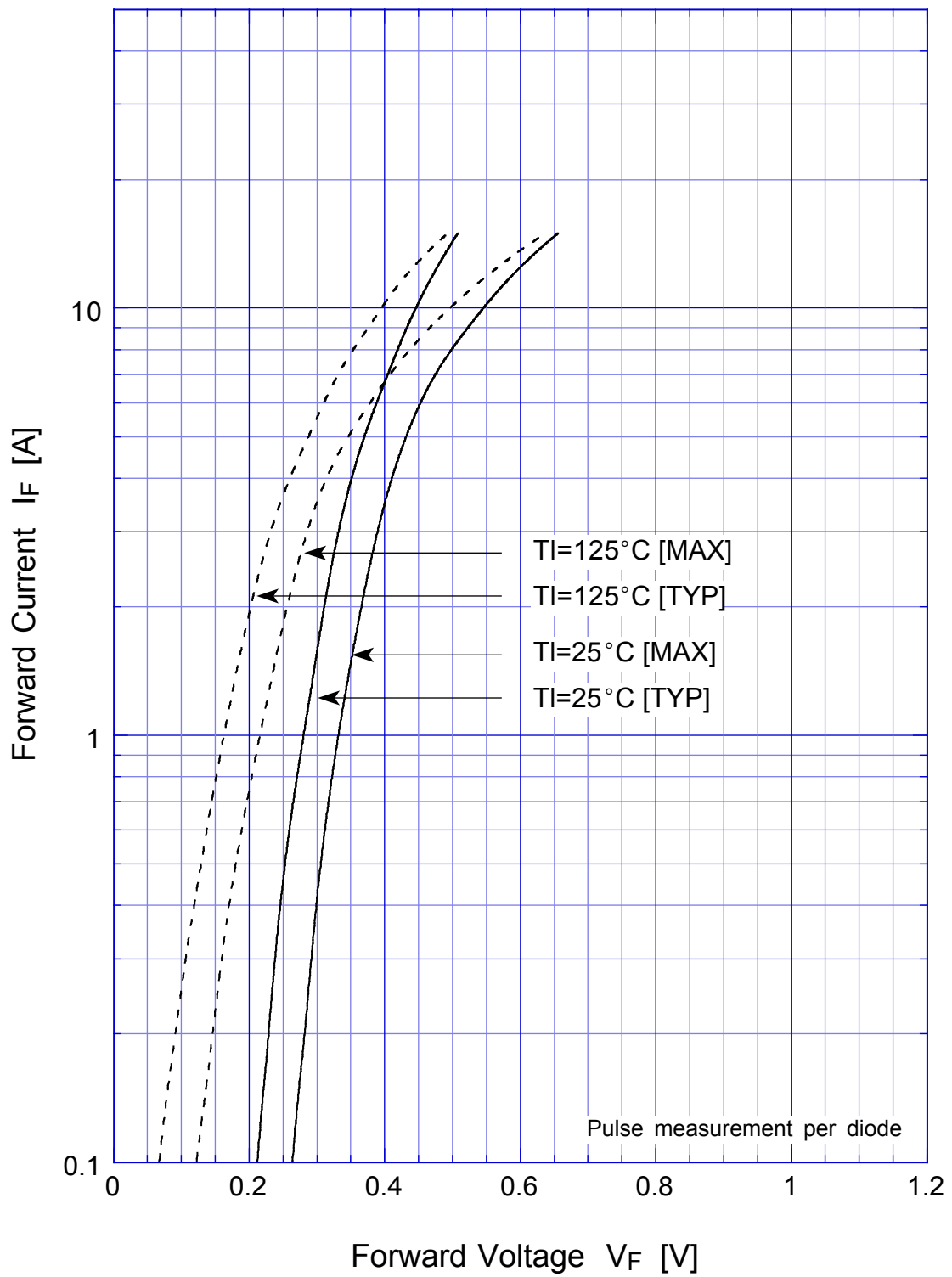

# D3FP3

## Junction Capacitance

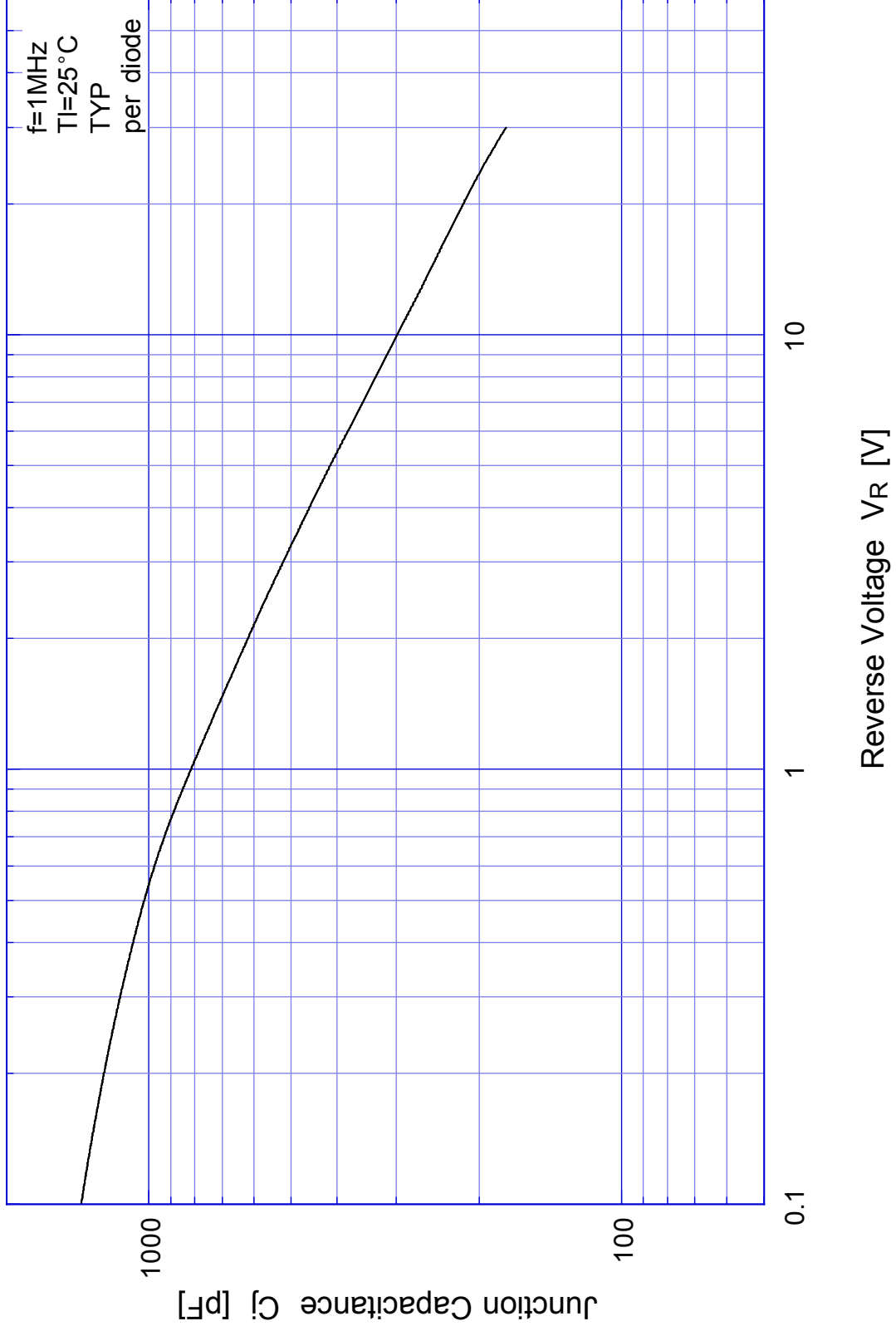

# D3FP3

# Reverse Current

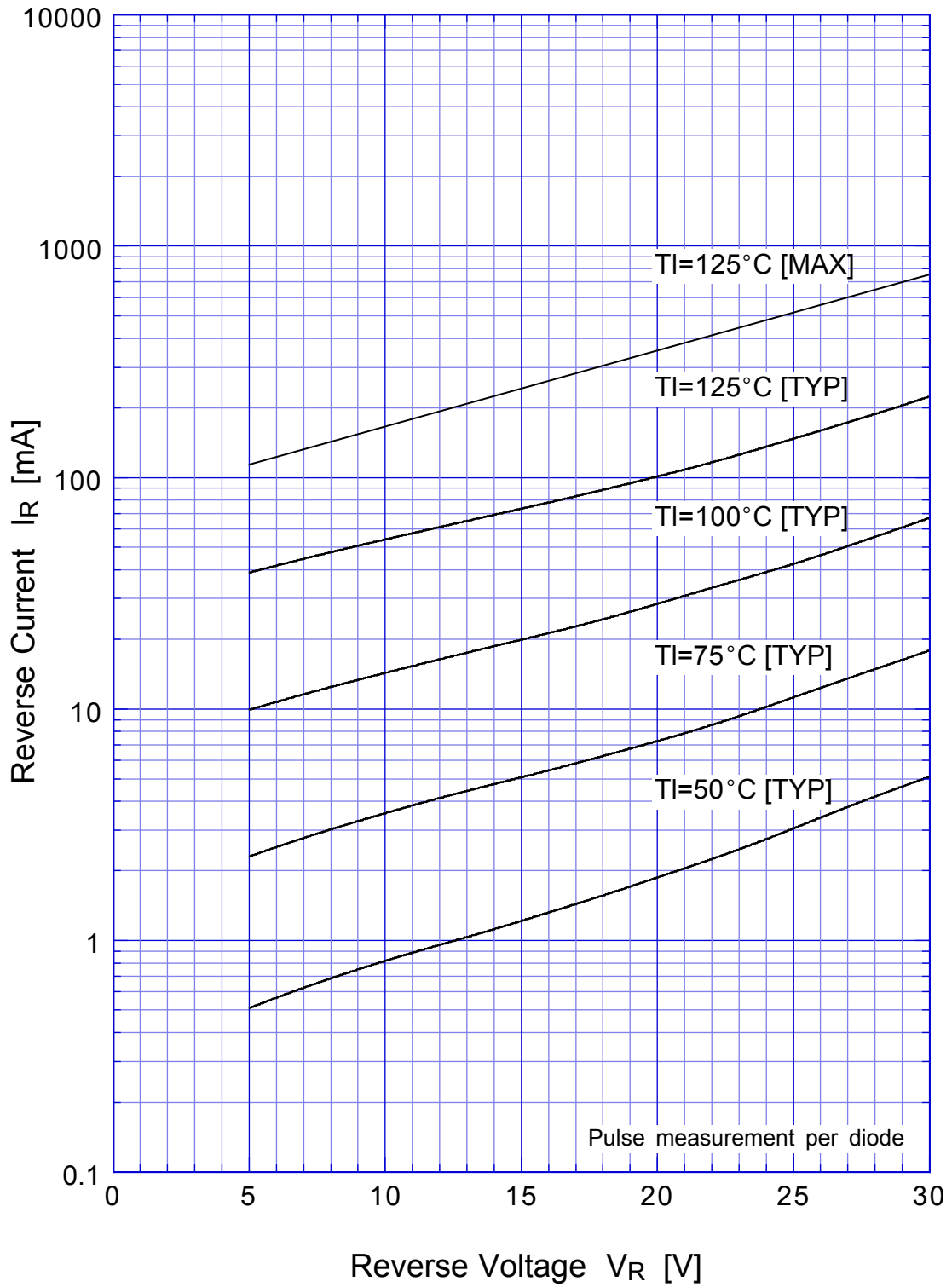

# D3FP3

## Reverse Power Dissipation

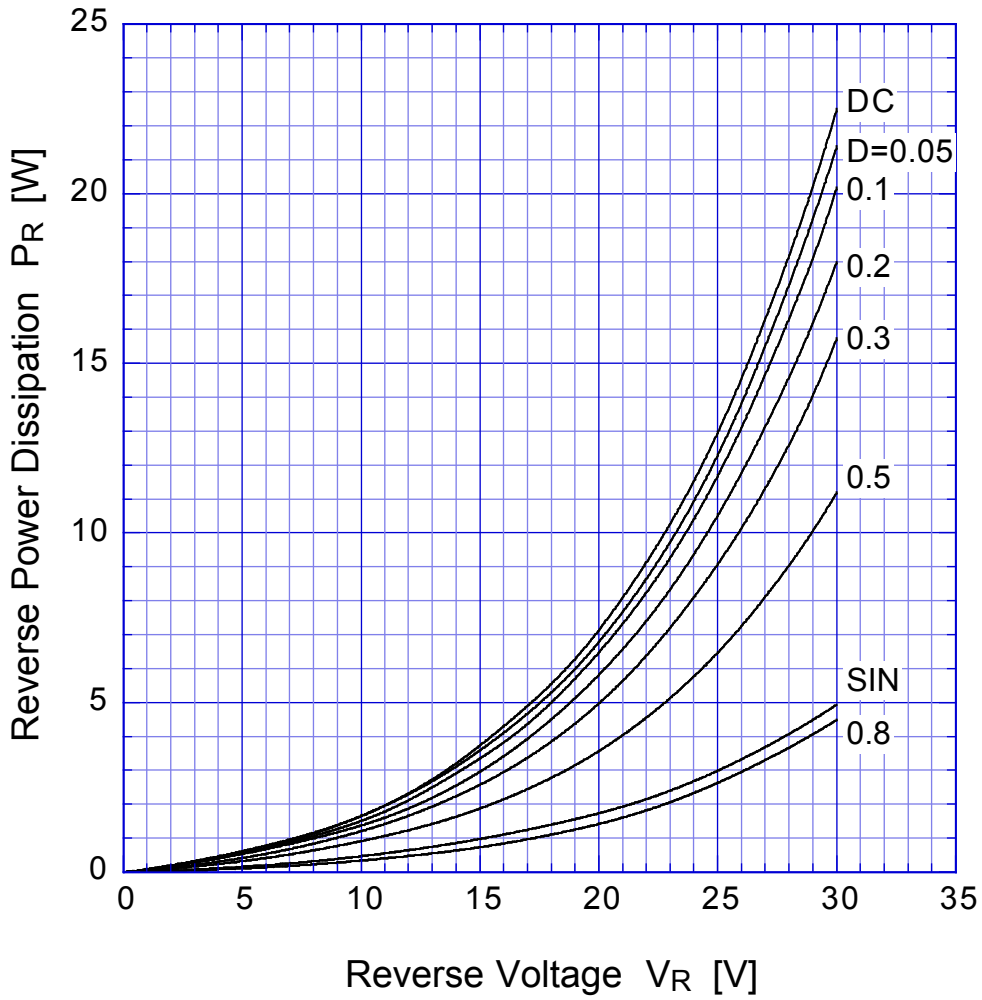

$T_j = 125^\circ\text{C}$

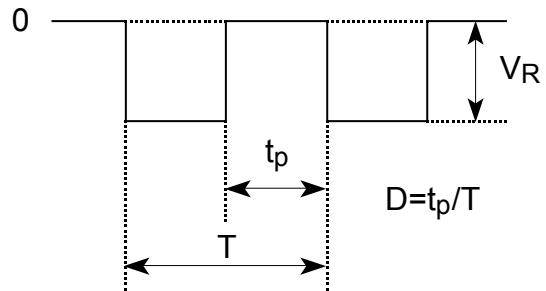

# D3FP3

## Forward Power Dissipation

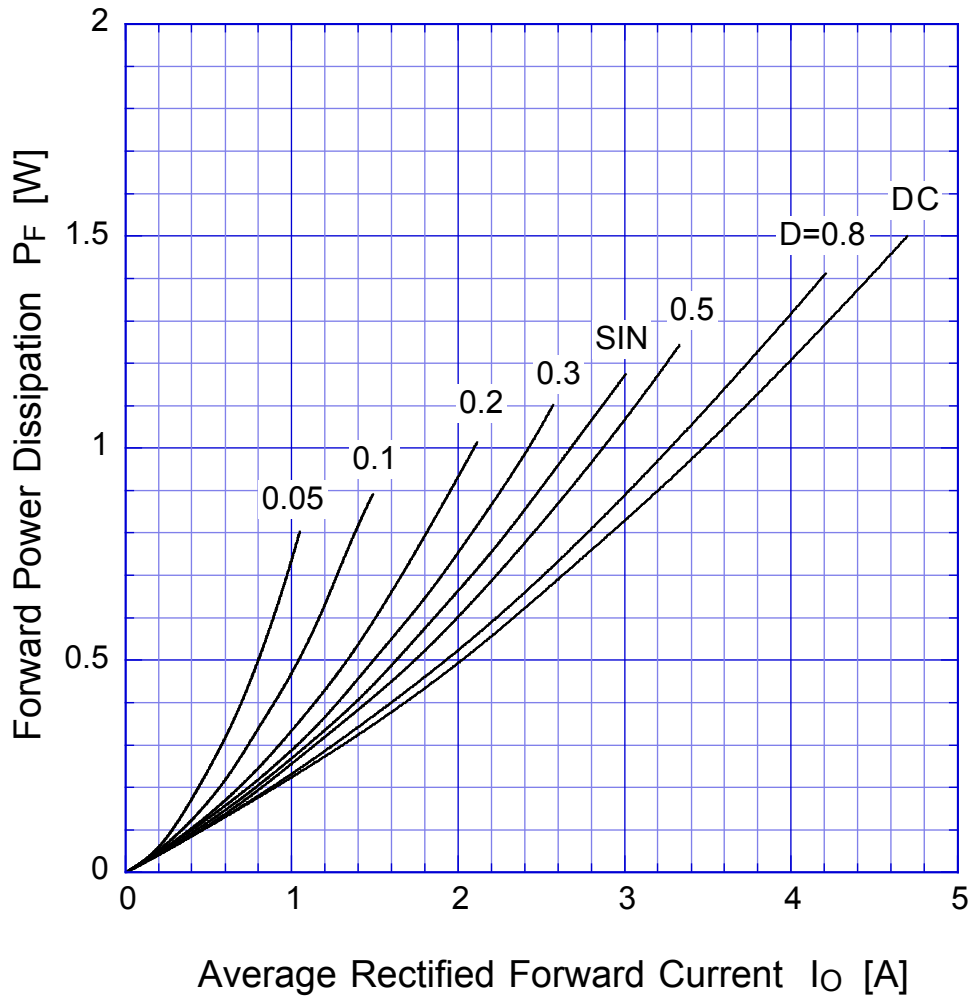

$T_j = 125^\circ\text{C}$

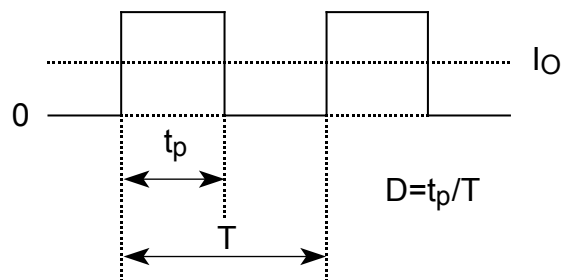

# D3FP3

# Derating Curve

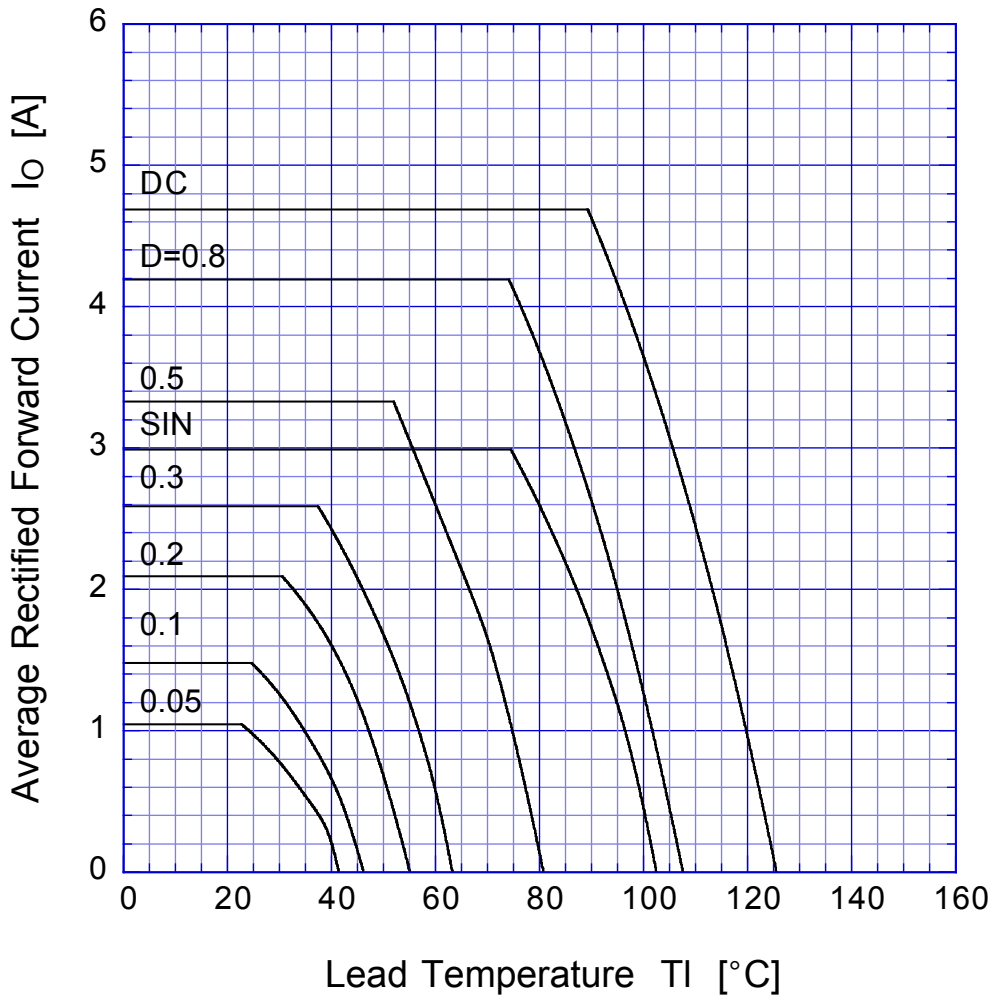

$V_R = 15V$



# D3FP3

## Peak Surge Forward Capability

