

SHINDENGEN

General Purpose Rectifiers

Single

M1FE40

400V 1A

OUTLINE DIMENSIONS

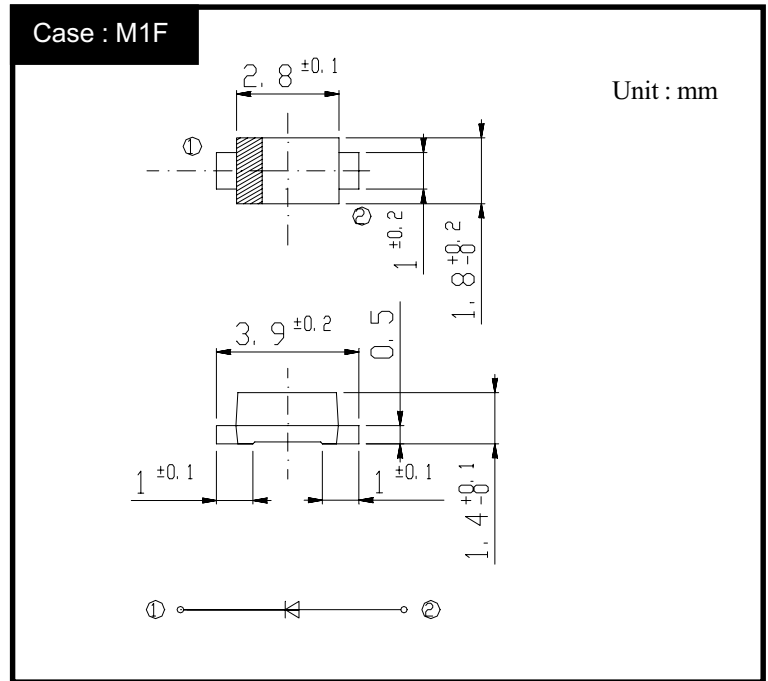

RATINGS

● Absolute Maximum Ratings (If not specified $T_I=25^{\circ}\text{C}$)

Item	Symbol	Conditions	Ratings	Unit
Storage Temperature	T_{stg}		-55~150	$^{\circ}\text{C}$
Operating Junction Temperature	T_j		150	$^{\circ}\text{C}$
Maximum Reverse Voltage	V_{RM}		400	V
Average Rectified Forward Current	I_O	50Hz sine wave, R-load $T_a=25^{\circ}\text{C}$ On glass-epoxy substrate	1.0	A
		50Hz sine wave, R-load $T_c=103^{\circ}\text{C}$	2.0	
Peak Surge Forward Current	I_{FSM}	50Hz sine wave, Non-repetitive 1 cycle peak value, $T_j=25^{\circ}\text{C}$	25	A

● Electrical Characteristics (If not specified $T_I=25^{\circ}\text{C}$)

Item	Symbol	Conditions	Ratings	Unit
Forward Voltage	V_F	$I_F=1\text{A}$, Pulse measurement	Max.1.1	V
Reverse Current	I_R	$V_R=V_{RM}$, Pulse measurement	Max.10	μA
Thermal Resistance	θ_{jl}	junction to lead	Max.20	$^{\circ}\text{C}/\text{W}$
	θ_{ja}	junction to ambient, On glass-epoxy substrate	Max.80	
	θ_{jc}	junction to case	Max.18	

M1FE40

Forward Voltage

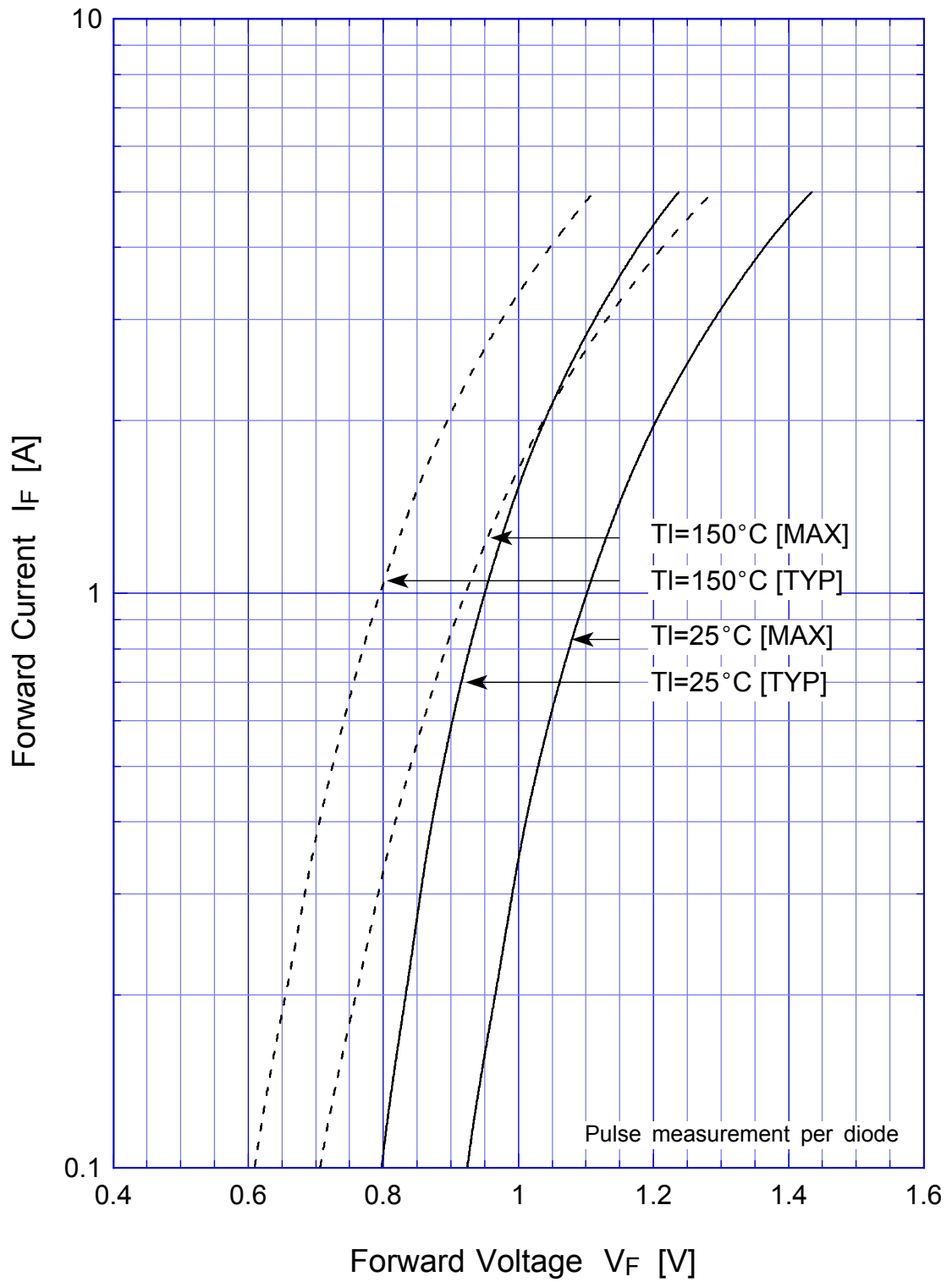

M1FE40 Forward Power Dissipation

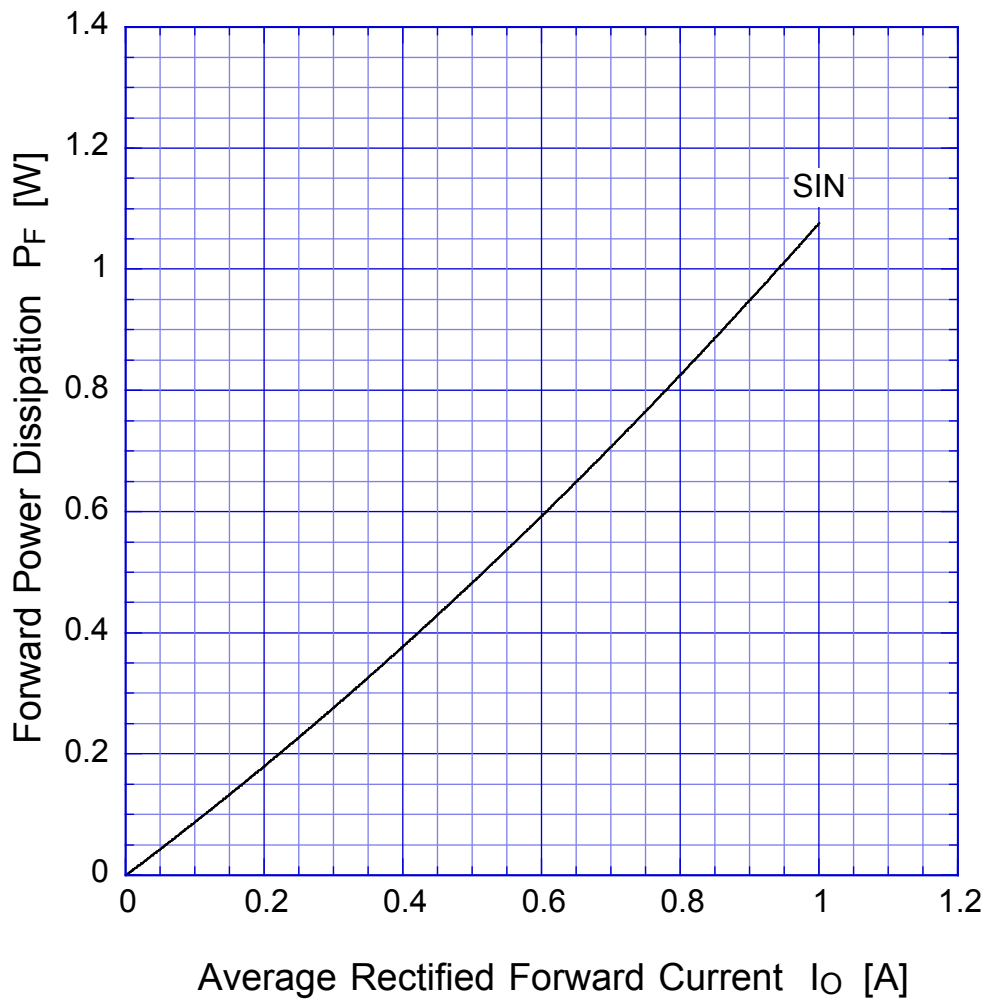

$T_j = 150^\circ\text{C}$
Sine wave

M1FE40

Derating Curve

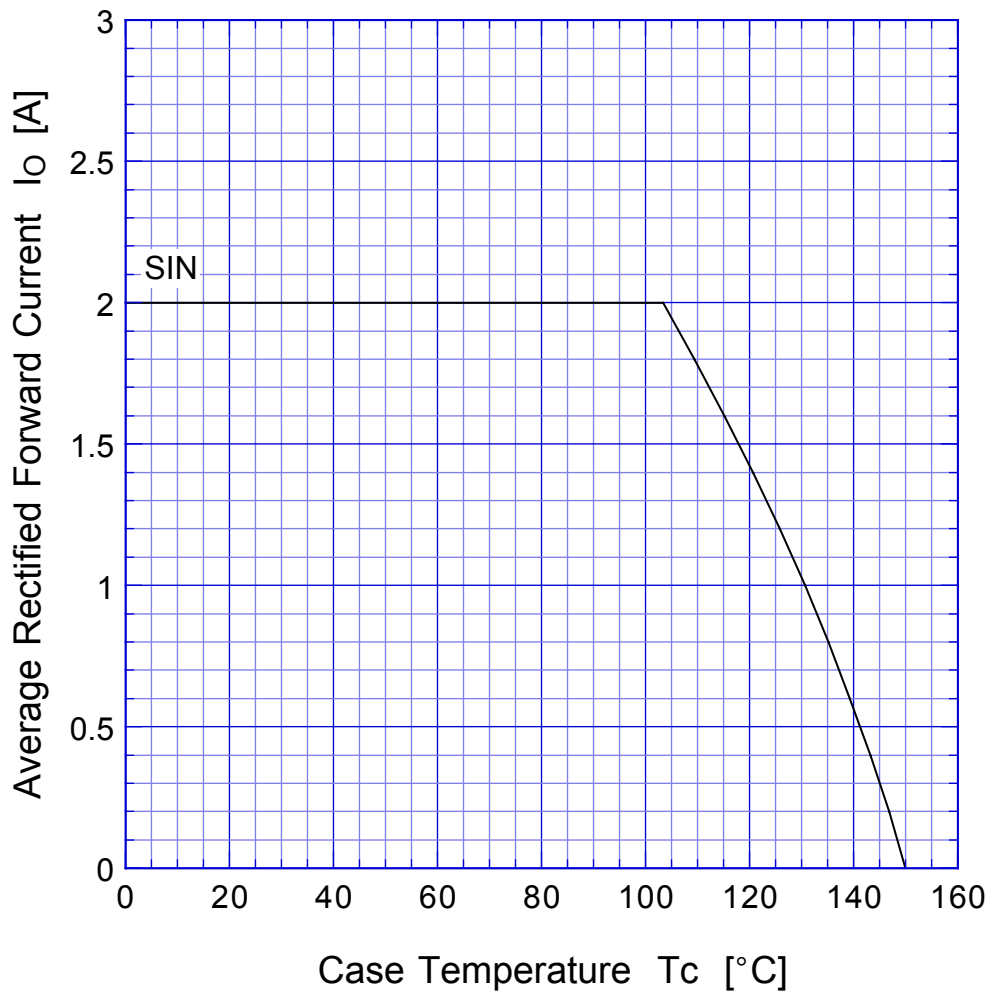

$$V_R = V_{RM}$$



M1FE40

Derating Curve

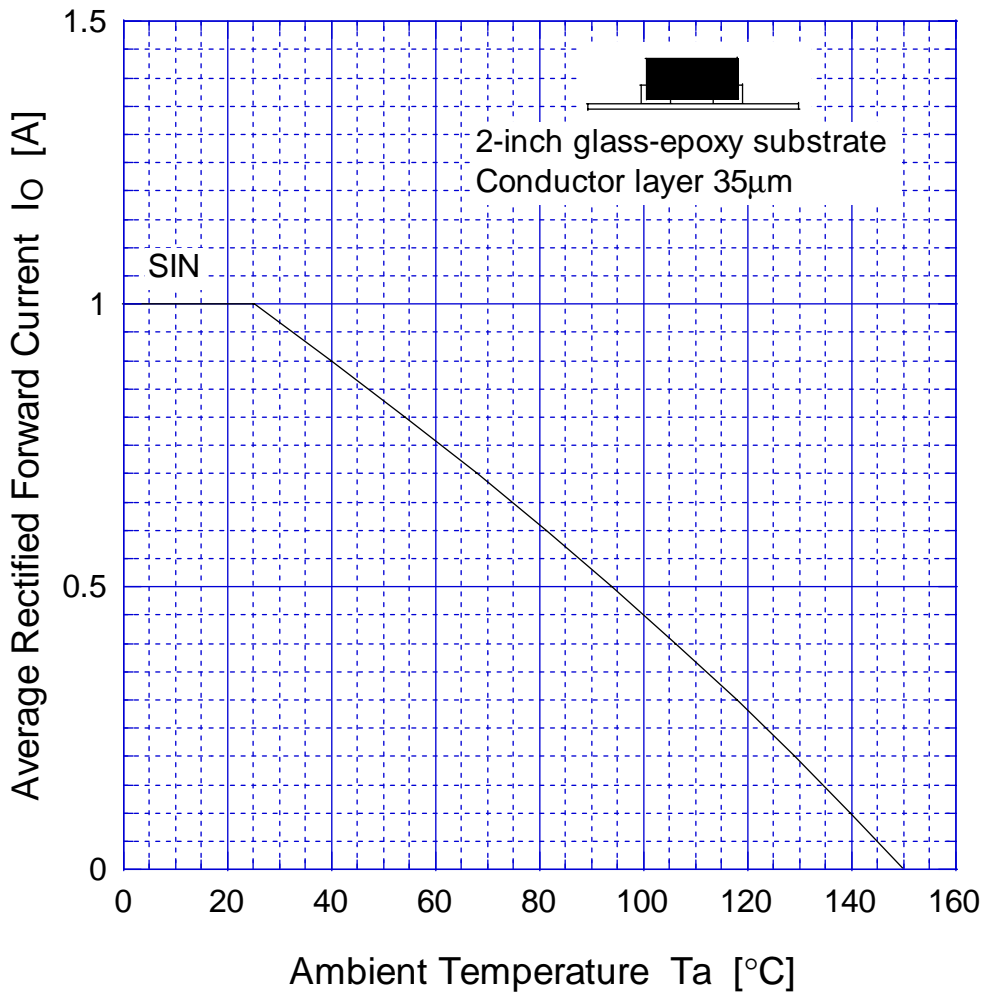

$$V_R = V_{RM}$$

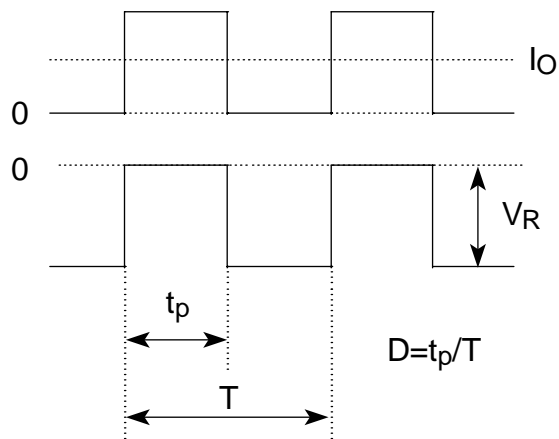

M1FE40

Peak Surge Forward Capability

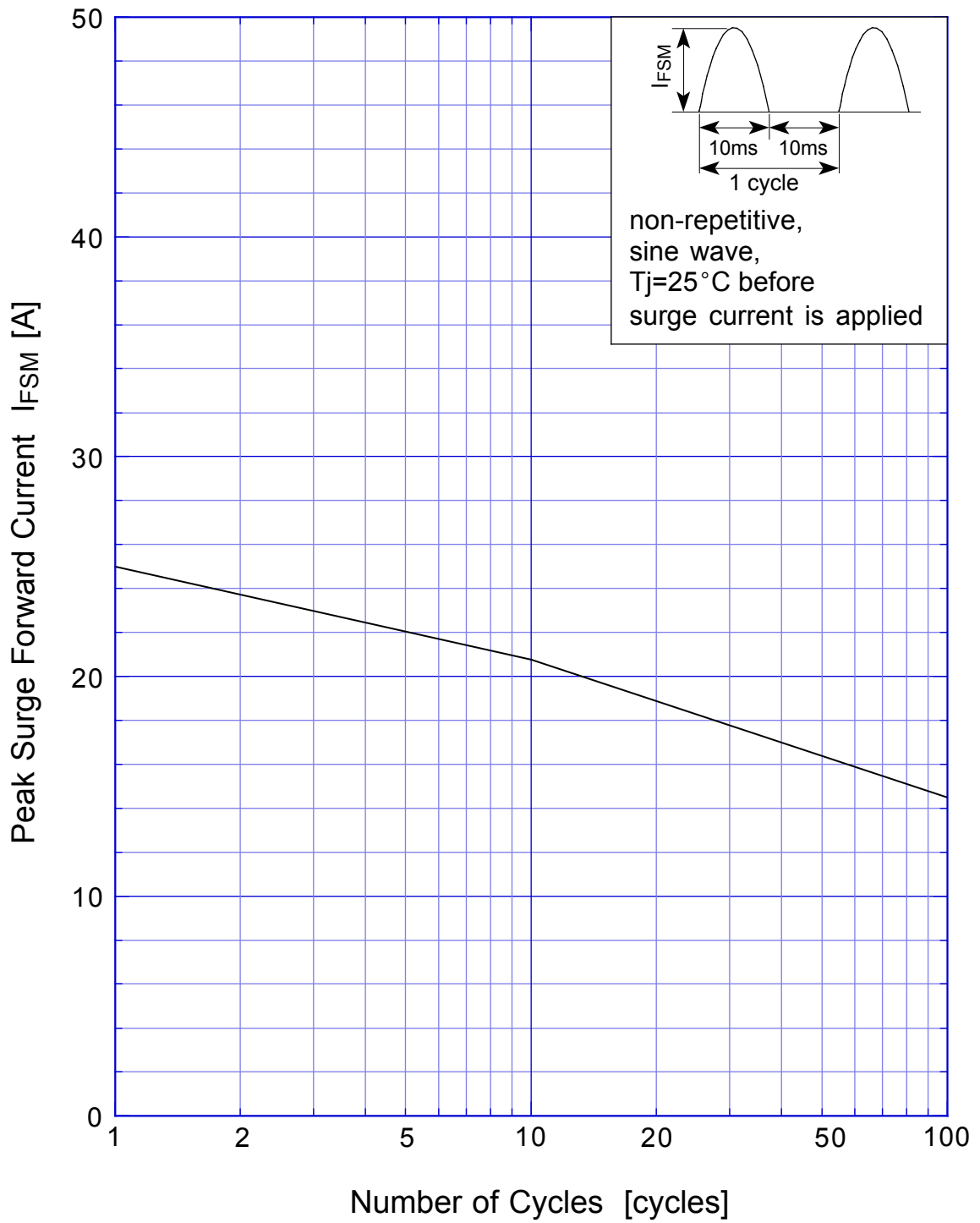

M1FE40 Transient Thermal Impedance

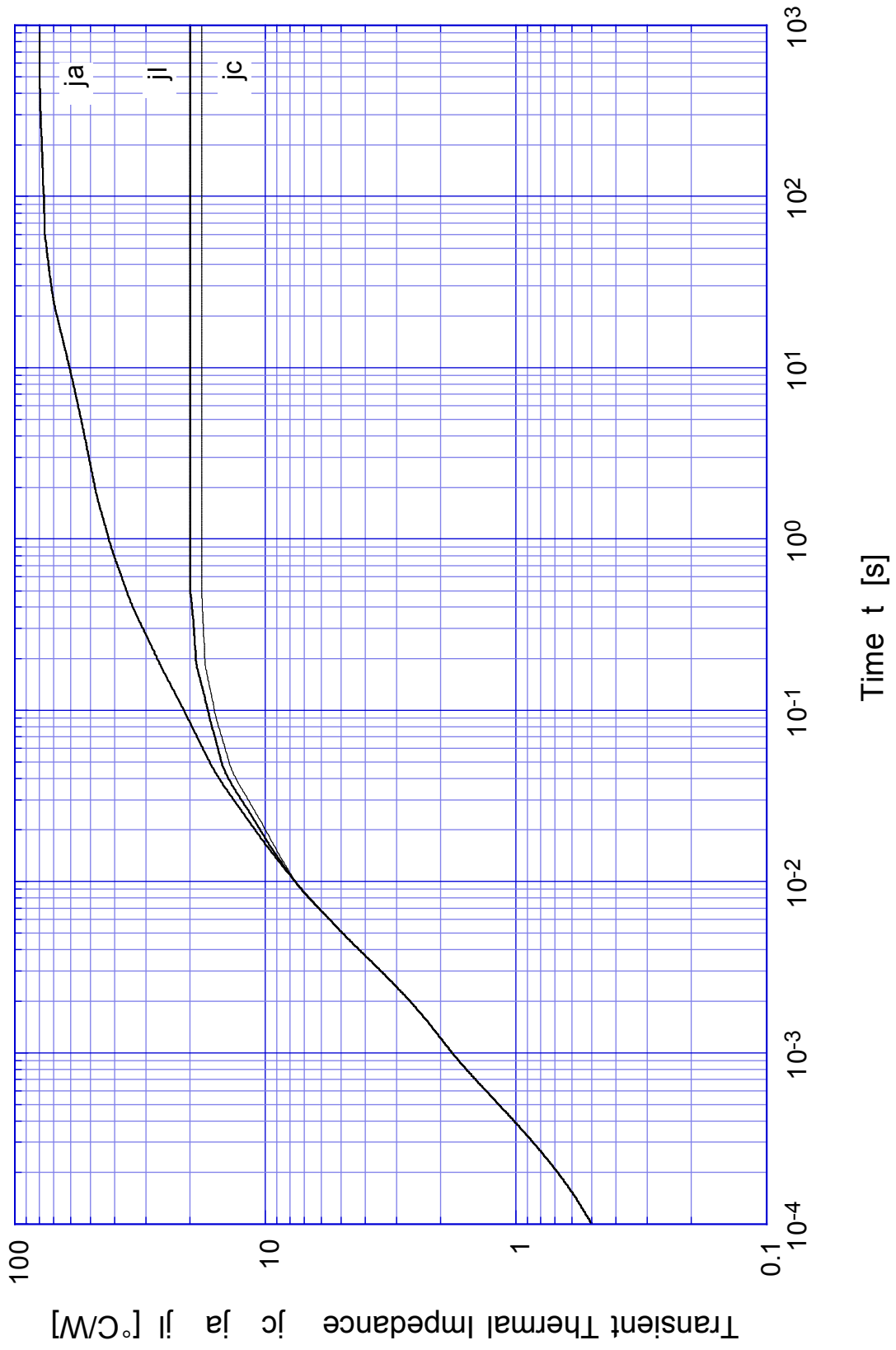

M1FE40 ja - Conductor Pattern Area

