

FEATURES

- 16-bit resolution and monotonicity**
- Pin selectable NAMUR-compliant ranges**
 - 4 mA to 20 mA
 - 3.8 mA to 21 mA
 - 3.2 mA to 24 mA
- NAMUR-compliant alarm currents**
 - Downscale alarm current = 3.2 mA
 - Upscale alarm current = 22.8 mA/24 mA
- Total unadjusted error (TUE): 0.05% maximum**
- INL error: 0.0035% FSR maximum**
- Output TC: 3 ppm/°C typical**
- Quiescent current: 300 μA maximum**
- Flexible SPI-compatible serial digital interface with Schmitt triggered inputs**
- On-chip fault alerts via FAULT pin or alarm current**
- Automatic readback of fault register on each write cycle**
- Slew rate control function**
- Gain and offset adjust registers**
- On-chip reference TC: 4 ppm/°C maximum**
- Selectable regulated voltage output**
- Loop voltage range: 5.5 V to 52 V**
- Temperature range: -40°C to +105°C**
- TSSOP and LFCSP packages**

APPLICATIONS

- Industrial process control
- 4 mA to 20 mA loop-powered transmitters
- Smart transmitters
- HART network connectivity

GENERAL DESCRIPTION

The AD5421 is a complete, loop-powered, 4 mA to 20 mA digital-to-analog converter (DAC) designed to meet the needs of smart transmitter manufacturers in the industrial control industry. The DAC provides a high precision, fully integrated, low cost solution in compact TSSOP and LFCSP packages.

The AD5421 includes a regulated voltage output that is used to power itself and other devices in the transmitter. This regulator provides a regulated 1.8 V to 12 V output voltage. The AD5421 also contains 1.22 V and 2.5 V references, thus eliminating the need for a discrete regulator and voltage reference.

The AD5421 can be used with standard HART® FSK protocol communication circuitry without any degradation in specified performance. The high speed serial interface is capable of operating at 30 MHz and allows for simple connection to commonly used microprocessors and microcontrollers via a SPI-compatible, 3-wire interface.

The AD5421 is guaranteed monotonic to 16 bits. It provides 0.0015% integral nonlinearity, 0.0012% offset error, and 0.0006% gain error under typical conditions.

The AD5421 is available in a 28-lead TSSOP and a 32-lead LFCSP specified over the extended industrial temperature range of -40°C to +105°C.

COMPANION LOW POWER PRODUCTS

HART Modem: [AD5700](#), [AD5700-1](#)

Microcontroller: [ADuCM360](#)

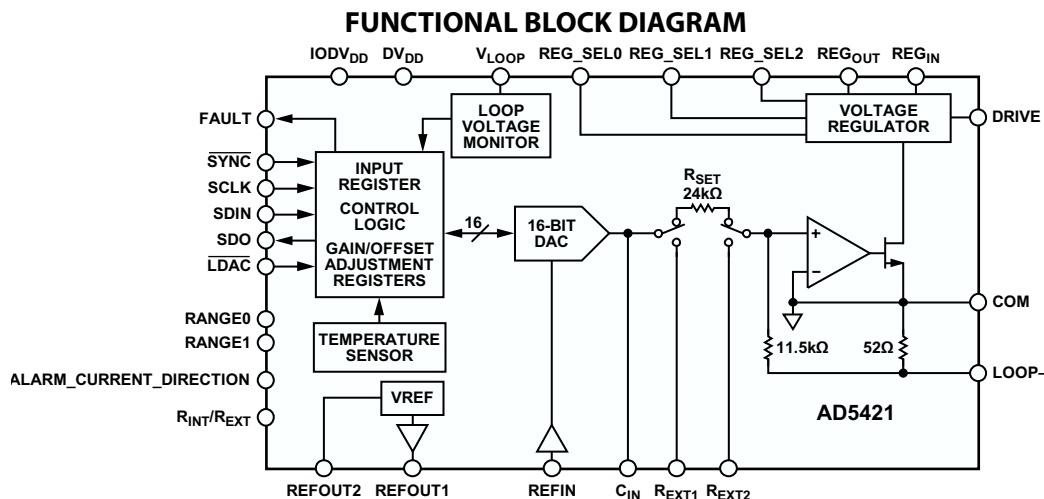

Figure 1.

Rev. G

Document Feedback

Information furnished by Analog Devices is believed to be accurate and reliable. However, no responsibility is assumed by Analog Devices for its use, nor for any infringements of patents or other rights of third parties that may result from its use. Specifications subject to change without notice. No license is granted by implication or otherwise under any patent or patent rights of Analog Devices. Trademarks and registered trademarks are the property of their respective owners.

TABLE OF CONTENTS

Features	1	On-Chip ADC	23
Applications.....	1	Voltage Regulator	23
General Description	1	Loop Current Slew Rate Control.....	23
Companion Low Power Products	1	Power-On Default	24
Functional Block Diagram	1	HART Communications	24
Revision History	3	Serial Interface	26
Specifications.....	4	Input Shift Register	26
AC Performance Characteristics	9	Register Readback	26
Timing Characteristics	9	DAC Register	27
Absolute Maximum Ratings.....	11	Control Register	28
Thermal Resistance	11	Fault Register	29
ESD Caution.....	11	Offset Adjust Register	30
Pin Configuration and Function Descriptions.....	12	Gain Adjust Register	30
Typical Performance Characteristics	14	Applications Information.....	32
Terminology	20	Determining the Expected Total Error	32
Theory of Operation	21	Thermal and Supply Considerations	34
Fault Alerts	21	Outline Dimensions	35
External Current Setting Resistor	22	Ordering Guide	36
Loop Current Range Selection.....	22		
Connection to Loop Power Supply	22		

REVISION HISTORY**10/13—Rev. F to Rev. G**

Added Figure 4; Renumbered Sequentially	10
Change to Table 7	11
Changes to Fault Alerts Section	21
Added Table 11; Renumbered Sequentially	24
Moved Figure 48	25
Changes to Applications Information Section	32
Changes to Figure 51	33

1/13—Rev. E to Rev. F

Moved Revision History Section	3
Change to Table 7	11
Changes to Table 8	13
Changes to On-Chip ADC Section	23
Changes to Table 19 and On-Chip ADC Transfer Function Equations Section	29

7/12—Rev. D to Rev. E

Changes to Figure 1 and Companion Products Section	1
Changes to Pin LOOP– Description	12
Changes to Applications Information Section and Figure 49 ...	31
Added Figure 50	32

5/12—Rev. C to Rev. D

Changes to Features Section and Applications Section; Added Companion Products Section	1
Changes to Line Regulation Parameter, Table 1	5
Updated Outline Dimensions	33

12/11—Rev. B to Rev. C

Change to REFOUT1 Pin, Capacitive Load Parameter, Test Conditions, Table 1	4
Change to REG _{OUT} Output, Capacitive Load Parameter, Test Conditions, Table 1	5
Changes to ESD Parameter, Table 6	10

12/11—Rev. A to Rev. B

Added 32-Lead LFCSP	Universal
Changes to the Specifications Section, Table 1	3
Changes to Table 7	10
Added Figure 5, Renumbered Sequentially	11
Changes to Table 8	11
Changes to Figure 33	17
Changes to the On-Chip ADC Section	22
Changes to Figure 46	23
Changes to Figure 48	24
Changes to the Register Readback Section	25
Updated Outline Dimensions	33
Changes to Ordering Guide	34

5/11—Rev. 0 to Rev. A

Changes to REG _{IN} , REFOUT1, and REFOUT2 Pin Descriptions in Table 8	10
Change to Figure 45	22
Changes to Input Shift Register Section, Table 11, and Register Readback Section	24
Changes to Figure 48	30

2/11—Revision 0: Initial Version

SPECIFICATIONS

Loop voltage = 24 V; REFIN = 2.5 V external; $R_L = 250\ \Omega$; external NMOS connected; all loop current ranges; all specifications T_{MIN} to T_{MAX} , unless otherwise noted.

Table 1.

Parameter ¹	Min	Typ	Max	Unit	Test Conditions/Comments
ACCURACY, INTERNAL R_{SET}					
Resolution	16			Bits	
Total Unadjusted Error (TUE) ²	-0.126		+0.126	% FSR	C grade
	-0.041	±0.0064	+0.041	% FSR	C grade, $T_A = 25^\circ\text{C}$
	-0.18		+0.18	% FSR	B grade
	-0.06	±0.011	+0.06	% FSR	B grade, $T_A = 25^\circ\text{C}$
	-0.27		+0.27	% FSR	A grade
	-0.08	±0.011	+0.08	% FSR	A grade, $T_A = 25^\circ\text{C}$
TUE Long-Term Stability		210		ppm FSR	Drift after 1000 hours at $T_A = 125^\circ\text{C}$
Relative Accuracy (INL)	-0.0035	±0.0015	+0.0035	% FSR	C grade
	-0.012	±0.006	+0.012	% FSR	B grade
	-0.024	±0.01	+0.024	% FSR	A grade
Differential Nonlinearity (DNL)	-1		+1	LSB	Guaranteed monotonic
Offset Error	-0.056		+0.056	% FSR	B grade and C grade
	-0.008	±0.0008	+0.008	% FSR	B grade and C grade, $T_A = 25^\circ\text{C}$
	-0.11	±0.0008	+0.11	% FSR	A grade
Offset Error TC^3		1		ppm FSR/ $^\circ\text{C}$	
Gain Error	-0.107		+0.107	% FSR	B grade and C grade
	-0.035	±0.0058	+0.035	% FSR	B grade and C grade, $T_A = 25^\circ\text{C}$
	-0.2	±0.0058	+0.2	% FSR	A grade
Gain Error TC^3		4		ppm FSR/ $^\circ\text{C}$	
Full-Scale Error	-0.126		+0.126	% FSR	B grade and C grade
	-0.041	±0.0065	+0.041	% FSR	B grade and C grade, $T_A = 25^\circ\text{C}$
	-0.25	±0.0065	+0.25	% FSR	A grade
Full-Scale Error TC^3		5		ppm FSR/ $^\circ\text{C}$	
Downscale Alarm Current	3.19		3.21	mA	
Upscale Alarm Current	22.77		22.83	mA	4 mA to 20 mA and 3.8 mA to 21 mA ranges
	23.97		24.03	mA	3.2 mA to 24 mA range
ACCURACY, EXTERNAL R_{SET} (24 kΩ)					
Resolution	16			Bits	
Total Unadjusted Error (TUE) ²	-0.048		+0.048	% FSR	C grade
	-0.027	±0.002	+0.027	% FSR	C grade, $T_A = 25^\circ\text{C}$
	-0.08		+0.08	% FSR	B grade
	-0.04	±0.003	+0.04	% FSR	B grade, $T_A = 25^\circ\text{C}$
TUE Long-Term Stability		40		ppm FSR	Drift after 1000 hours at $T_A = 125^\circ\text{C}$
Relative Accuracy (INL)	-0.0035	±0.0015	+0.0035	% FSR	C grade
	-0.012	±0.006	+0.012	% FSR	B grade
Differential Nonlinearity (DNL)	-1		+1	LSB	Guaranteed monotonic
Offset Error	-0.021		+0.021	% FSR	
	-0.007	±0.0012	+0.007	% FSR	$T_A = 25^\circ\text{C}$
Offset Error TC^3		0.5		ppm FSR/ $^\circ\text{C}$	
Gain Error	-0.03		+0.03	% FSR	
	-0.023	±0.0006	+0.023	% FSR	$T_A = 25^\circ\text{C}$

Parameter ¹	Min	Typ	Max	Unit	Test Conditions/Comments
Gain Error TC ³		1		ppm FSR/°C	
Full-Scale Error	-0.047		+0.047	% FSR	T _A = 25°C
	-0.028	±0.0017	+0.028	% FSR	
Full-Scale Error TC ³		1		ppm FSR/°C	
Downscale Alarm Current	3.08		3.21	mA	4 mA to 20 mA and 3.8 mA to 21 mA ranges
Upscale Alarm Current	22.78		23	mA	
	23.99		24.01	mA	
OUTPUT CHARACTERISTICS³					
Loop Compliance Voltage ⁴	LOOP- + 5.5 LOOP- + 12.5			V V	REG _{OUT} < 5.5 V, loop current = 24 mA REG _{OUT} = 12 V, loop current = 24 mA
Loop Current Long-Term Stability		100		ppm FSR	Drift after 1000 hours at T _A = 125°C, loop current = 12 mA, internal R _{SET}
		15		ppm FSR	Drift after 1000 hours at T _A = 125°C, loop current = 12 mA, external R _{SET}
Loop Current Error vs. REG _{OUT} Load Current		1.2		μA/mA	Loop current = 12 mA, load current from REG _{OUT} = 5 mA
Resistive Load	0		2	kΩ	See Figure 21 for a load line graph
Inductive Load		50		mH	Stable operation
Power Supply Sensitivity			0.1	μA/V	Loop current = 12 mA
Output Impedance	12	400		MΩ	
Output TC		3		ppm FSR/°C	Loop current = 12 mA, internal R _{SET}
		1		ppm FSR/°C	Loop current = 12 mA, external R _{SET}
Output Noise					
0.1 Hz to 10 Hz		50		nA p-p	
500 Hz to 10 kHz		0.2		mV rms	HART bandwidth; measured across 500 Ω load
Noise Spectral Density		195		nA/√Hz	At 1 kHz
		256		nA/√Hz	At 10 kHz
REFERENCE INPUT (REFIN PIN)³					
Reference Input Voltage ⁵		2.5		V	For specified performance
DC Input Impedance	75	800		MΩ	
REFERENCE OUTPUTS					
REFOUT1 Pin					
Output Voltage	2.498	2.5	2.503	V	T _A = 25°C
Temperature Coefficient		1.5	4	ppm/°C	C grade
		2	8	ppm/°C	B grade
		4	10	ppm/°C	A grade
Output Noise (0.1 Hz to 10 Hz) ³		7.5		μV p-p	
Noise Spectral Density ³		245		nV/√Hz	At 1 kHz
		70		nV/√Hz	At 10 kHz
Output Voltage Drift vs. Time ³		200		ppm	Drift after 1000 hours at T _A = 125°C
Capacitive Load ³		10		nF	Recommended operation
Load Current ^{3, 6}		4		mA	
Short-Circuit Current ³		6.5		mA	Short circuit to COM
Power Supply Sensitivity ³		2	12	μV/V	
Thermal Hysteresis ³		285		ppm	First temperature cycle
		5		ppm	Second temperature cycle
Load Regulation ³		0.1	0.2	mV/mA	Measured at 0 mA and 1 mA loads
Output Impedance		0.1		Ω	
REFOUT2 Pin					
Output Voltage	1.18	1.227	1.28	V	T _A = 25°C
Output Impedance		72		kΩ	

Parameter ¹	Min	Typ	Max	Unit	Test Conditions/Comments
REG _{OUT} OUTPUT					Voltage regulator output See Table 10
Output Voltage	1.8		12	V	
Output Voltage TC ³		110		ppm/°C	
Output Voltage Accuracy	-4	±2	+4	%	
Externally Available Current ^{3,6}	3.15			mA	Assuming 4 mA flowing in the loop and during HART communications
Short-Circuit Current		23		mA	
Line Regulation ³		500		μV/V	Internal NMOS
		10		μV/V	External NMOS
Load Regulation ³		8		mV/mA	
Inductive Load		50		mH	Stable operation
Capacitive Load	2	10		μF	Recommended operation
ADC ACCURACY					
Die Temperature		±5		°C	
V _{LOOP} Input		±1		%	
DV _{DD} OUTPUT					Can be overdriven up to 5.5 V
Output Voltage	3.17	3.3	3.48	V	
Externally Available Current ^{3,6}	3.15			mA	Assuming 4 mA flowing in the loop and during HART communications
Short-Circuit Current		7.7		mA	
Load Regulation		45		mV/mA	Measured at 0 mA and 3 mA loads
DIGITAL INPUTS ³					SCLK, SYNC, SDIN, LDAC
Input High Voltage, V _{IH}	0.7 × IODV _{DD}			V	
Input Low Voltage, V _{IL}			0.25 × IODV _{DD}	V	
Hysteresis		0.21		V	IODV _{DD} = 1.8 V
		0.63		V	IODV _{DD} = 3.3 V
		1.46		V	IODV _{DD} = 5.5 V
Input Current	-0.015		+0.015	μA	Per pin
Pin Capacitance		5		pF	Per pin
DIGITAL OUTPUTS ³					
SDO Pin					
Output Low Voltage, V _{OL}			0.4	V	
Output High Voltage, V _{OH}	IODV _{DD} - 0.5			V	
High Impedance Leakage Current	-0.01		+0.01	μA	
High Impedance Output Capacitance		5		pF	
FAULT Pin					
Output Low Voltage, V _{OL}			0.4	V	
Output High Voltage, V _{OH}	IODV _{DD} - 0.5			V	
FAULT THRESHOLDS					
I _{LOOP} Under		I _{LOOP} - 0.01% FSR		mA	
I _{LOOP} Over		I _{LOOP} + 0.01% FSR		mA	
Temp 140°C		133		°C	Fault removed when temperature ≤ 125°C
Temp 100°C		90		°C	Fault removed when temperature ≤ 85°C
V _{LOOP} 6V		0.3		V	Fault removed when V _{LOOP} ≥ 0.4 V
V _{LOOP} 12V		0.6		V	Fault removed when V _{LOOP} ≥ 0.7 V

Parameter ¹	Min	Typ	Max	Unit	Test Conditions/Comments
POWER REQUIREMENTS					
REG _{IN}	5.5		52	V	With respect to LOOP–
IODV _{DD}	1.71		5.5	V	With respect to COM
Quiescent Current		260	300	μA	

¹ Temperature range: –40°C to +105°C; typical at +25°C.

² Total unadjusted error is the total measured error (offset error + gain error + linearity error + output drift over temperature) after factory calibration of the [AD5421](#). System level total error can be reduced using the offset and gain registers.

³ Guaranteed by design and characterization; not production tested.

⁴ The voltage between LOOP– and REG_{IN} must be 5.5 V or greater.

⁵ The [AD5421](#) is factory calibrated with an external 2.5 V reference connected to REFIN.

⁶ This is the current that the output is capable of sourcing. The load current originates from the loop and, therefore, contributes to the total current consumption figure.

Loop voltage = 24 V; REFIN = REFOUT1 (2.5 V internal reference); $R_L = 250 \Omega$; external NMOS connected; all loop current ranges; all specifications T_{MIN} to T_{MAX} , unless otherwise noted.

Table 2.

Parameter ^{1,2}	C Grade			Unit	Test Conditions/Comments
	Min	Typ	Max		
ACCURACY, INTERNAL R_{SET}					
Total Unadjusted Error (TUE) ³	-0.157		+0.157	% FSR	
	-0.117	± 0.0172	+0.117	% FSR	$T_A = 25^\circ\text{C}$
Relative Accuracy (INL)	-0.004		+0.004	% FSR	
	-0.004	± 0.0015	+0.004	% FSR	$T_A = 25^\circ\text{C}$
Offset Error	-0.04		+0.04	% FSR	
	-0.025	± 0.0025	+0.025	% FSR	$T_A = 25^\circ\text{C}$
Offset Error TC		1		ppm FSR/ $^\circ\text{C}$	
Gain Error	-0.128		+0.128	% FSR	
	-0.093	± 0.0137	+0.093	% FSR	$T_A = 25^\circ\text{C}$
Gain Error TC		5		ppm FSR/ $^\circ\text{C}$	
Full-Scale Error	-0.157		+0.157	% FSR	
	-0.117	± 0.0172	+0.117	% FSR	$T_A = 25^\circ\text{C}$
Full-Scale Error TC		6		ppm FSR/ $^\circ\text{C}$	
ACCURACY, EXTERNAL R_{SET} (24 k Ω)					
Total Unadjusted Error (TUE) ³	-0.133		+0.133	% FSR	Assumes ideal resistor
	-0.133	± 0.0252	+0.133	% FSR	$T_A = 25^\circ\text{C}$
Relative Accuracy (INL)	-0.004		+0.004	% FSR	
	-0.004	± 0.0015	+0.004	% FSR	$T_A = 25^\circ\text{C}$
Offset Error	-0.029		+0.029	% FSR	
	-0.029	± 0.0038	+0.029	% FSR	$T_A = 25^\circ\text{C}$
Offset Error TC		0.5		ppm FSR/ $^\circ\text{C}$	
Gain Error	-0.11		+0.11	% FSR	
	-0.106	± 0.0197	+0.106	% FSR	$T_A = 25^\circ\text{C}$
Gain Error TC		2		ppm FSR/ $^\circ\text{C}$	
Full-Scale Error	-0.133		+0.133	% FSR	
	-0.133	± 0.0252	+0.133	% FSR	$T_A = 25^\circ\text{C}$
Full-Scale Error TC		2		ppm FSR/ $^\circ\text{C}$	

¹ Temperature range: -40°C to $+105^\circ\text{C}$; typical at $+25^\circ\text{C}$.

² Specifications guaranteed by design and characterization; not production tested.

³ Total unadjusted error is the total measured error (offset error + gain error + linearity error + output drift over temperature) after factory calibration of the AD5421. System level total error can be reduced using the offset and gain registers.

AC PERFORMANCE CHARACTERISTICS

Loop voltage = 24 V; REFIN = 2.5 V external; $R_L = 250 \Omega$; all specifications T_{MIN} to T_{MAX} , unless otherwise noted.

Table 3.

Parameter ¹	Min	Typ	Max	Unit	Test Conditions/Comments
DYNAMIC PERFORMANCE					
Loop Current Settling Time		50		μs	To 0.1% FSR, $C_{IN} = \text{open circuit}$
Loop Current Slew Rate		400		$\mu\text{A}/\mu\text{s}$	$C_{IN} = \text{open circuit}$
AC Loop Voltage Sensitivity		1.3		$\mu\text{A}/\text{V}$	1200 Hz to 2200 Hz, 5 V p-p, $R_L = 3 \text{ k}\Omega$

¹ Temperature range: -40°C to $+105^\circ\text{C}$; typical at $+25^\circ\text{C}$.

TIMING CHARACTERISTICS

Loop voltage = 24 V; REFIN = 2.5 V external; $R_L = 250 \Omega$; all specifications T_{MIN} to T_{MAX} .

Table 4.

Parameter ^{1, 2, 3}	Limit at T_{MIN}, T_{MAX}	Unit	Description
t_1	33	ns min	SCLK cycle time
t_2	17	ns min	SCLK high time
t_3	17	ns min	SCLK low time
t_4	17	ns min	$\overline{\text{SYNC}}$ falling edge to SCLK falling edge setup time
t_5	10	ns min	SCLK falling edge to $\overline{\text{SYNC}}$ rising edge
t_6	25	μs min	Minimum $\overline{\text{SYNC}}$ high time
t_7	5	ns min	Data setup time
t_8	5	ns min	Data hold time
t_9	25	μs min	$\overline{\text{SYNC}}$ rising edge to $\overline{\text{LDAC}}$ falling edge
t_{10}	10	ns min	$\overline{\text{LDAC}}$ pulse width low
t_{11}	70	ns max	SCLK rising edge to SDO valid ($C_{LSDO} = 30 \text{ pF}$)
t_{12}	0	ns min	$\overline{\text{SYNC}}$ falling edge to SCLK rising edge setup time
t_{13}	70	ns max	$\overline{\text{SYNC}}$ rising edge to SDO tristate ($C_{LSDO} = 30 \text{ pF}$)

¹ Guaranteed by design and characterization; not production tested.

² All input signals are specified with $t_r = t_f = 5 \text{ ns}$ (10% to 90% of DV_{DD}) and timed from a voltage level of 1.2 V.

³ See Figure 2 and Figure 3.

Table 5. SPI Watchdog Timeout Periods

Parameter ¹			Min	Typ	Max	Unit
T0	T1	T2				
0	0	0	43	50	59	ms
0	0	1	87	100	117	ms
0	1	0	436	500	582	ms
0	1	1	873	1000	1163	ms
1	0	0	1746	2000	2326	ms
1	0	1	2619	3000	3489	ms
1	1	0	3493	4000	4652	ms
1	1	1	4366	5000	5814	ms

¹ Specifications guaranteed by design and characterization; not production tested.

Timing Diagrams

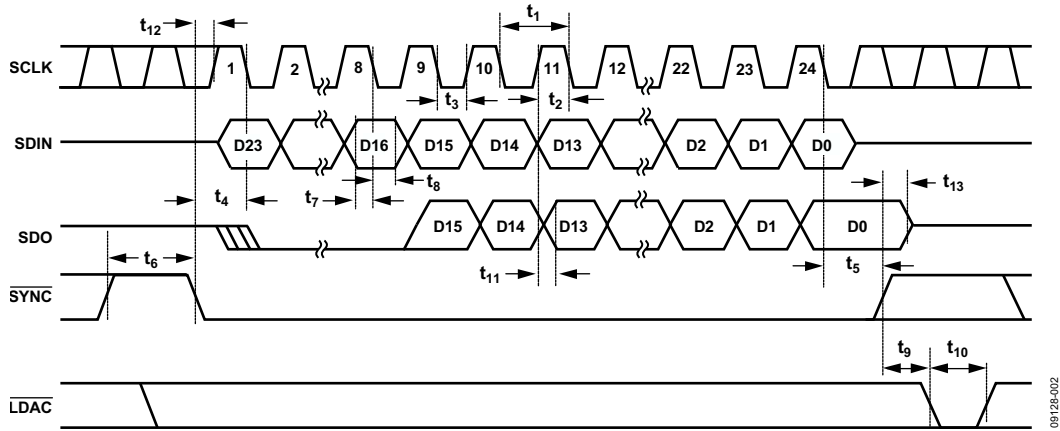

Figure 2. Serial Interface Timing Diagram

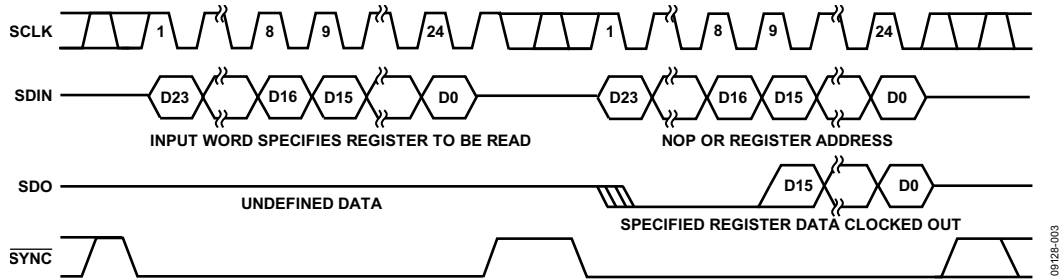

Figure 3. Readback Timing Diagram

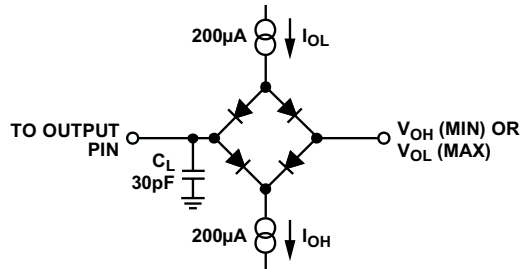

Figure 4. SDO Load Diagram

ABSOLUTE MAXIMUM RATINGS

$T_A = 25^\circ\text{C}$, unless otherwise noted. Transient currents of up to 100 mA do not cause SCR latch-up.

Table 6.

Parameter	Rating
REG _{IN} to COM	−0.3 V to +60 V
REG _{OUT} to COM	−0.3 V to +14 V
Digital Inputs to COM, RANGE0, RANGE1, R _{INT} /R _{EXT} , ALARM_CURRENT_DIRECTION, REG_SEL0, REG_SEL1, REG_SEL2	−0.3 V to DV _{DD} + 0.3 V or +7 V (whichever is less)
Digital Inputs to COM SCLK, SDIN, SYNC, LDAC	−0.3 V to IODV _{DD} + 0.3 V or +7 V (whichever is less)
Digital Outputs to COM, SDO, FAULT	−0.3 V to IODV _{DD} + 0.3 V or +7 V (whichever is less)
REFIN to COM	−0.3 V to +7 V
REFOUT1, REFOUT2	−0.3 V to +4.7 V
V _{LOOP} to COM	−0.3 V to +60 V
LOOP− to COM	−5 V to +0.3 V
DV _{DD} to COM	−0.3 V to +7 V
IODV _{DD} to COM	−0.3 V to +7 V
R _{EXT1} , C _{IN} to COM	−0.3 V to +4.3 V
R _{EXT2} to COM	−0.3 V to +0.3 V
DRIVE to COM	−0.3 V to +11 V
Operating Temperature Range (T_A) Industrial	−40°C to +105°C
Storage Temperature Range	−65°C to +150°C
Junction Temperature ($T_{J\text{MAX}}$)	125°C
Power Dissipation	$(T_{J\text{MAX}} - T_A)/\theta_{JA}$
Lead Temperature, Soldering (10 sec)	JEDEC Industry Standard J-STD-020
ESD	
Human Body Model	3 kV
Field Induced Charged Device Model	2 kV
Machine Model	200 V

Stresses above those listed under Absolute Maximum Ratings may cause permanent damage to the device. This is a stress rating only; functional operation of the device at these or any other conditions above those indicated in the operational section of this specification is not implied. Exposure to absolute maximum rating conditions for extended periods may affect device reliability.

THERMAL RESISTANCE

θ_{JA} is specified for the worst-case conditions, that is, a device soldered in a circuit board for surface-mount packages.

Table 7. Thermal Resistance

Package Type	θ_{JA}^1	θ_{JC}	Unit
28-Lead TSSOP_EP (RE-28-2)	32	9	°C/W
32-Lead LFCSP_WQ (CP-32-11)	40	7	°C/W

¹ Thermal impedance simulated values are based on JEDEC 2S2P thermal test board with thermal vias. See JEDEC JESD51.

ESD CAUTION



ESD (electrostatic discharge) sensitive device. Charged devices and circuit boards can discharge without detection. Although this product features patented or proprietary protection circuitry, damage may occur on devices subjected to high energy ESD. Therefore, proper ESD precautions should be taken to avoid performance degradation or loss of functionality.

PIN CONFIGURATION AND FUNCTION DESCRIPTIONS

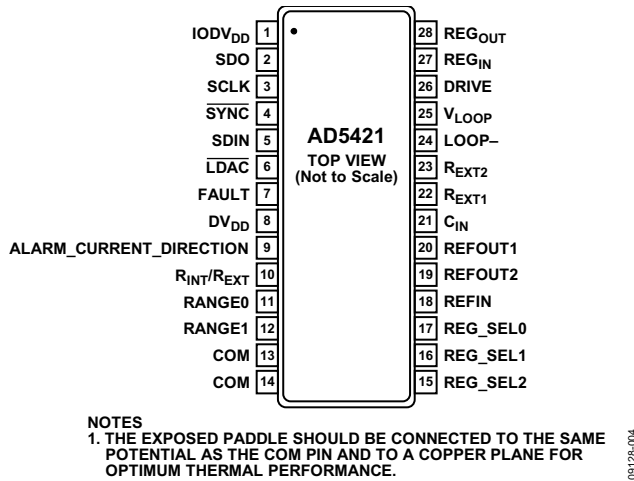

Figure 5. TSSOP Pin Configuration

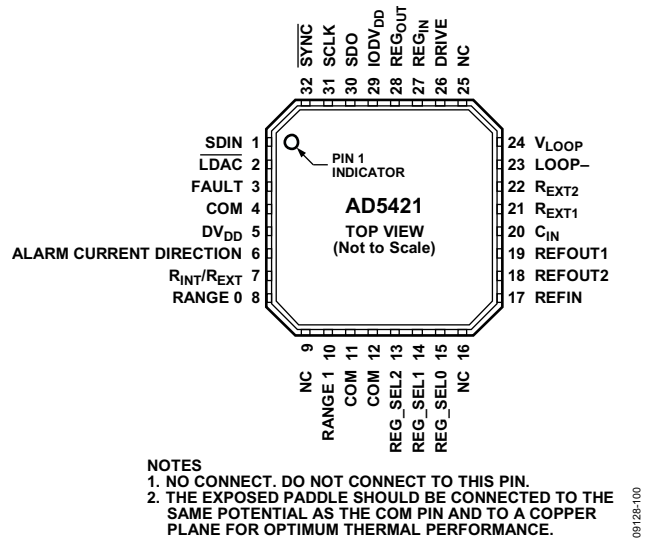

Figure 6. LFCSP Pin Configuration

Table 8. Pin Function Descriptions

Pin No.		Mnemonic	Description
TSSOP	LFCSP		
1	29	IODV _{DD}	Digital Interface Supply Pin. Digital thresholds are referenced to the voltage applied to this pin. A voltage from 1.71 V to 5.5 V can be applied to this pin.
2	30	SDO	Serial Data Output. Used to clock data from the input shift register. Data is clocked out on the rising edge of SCLK and is valid on the falling edge of SCLK.
3	31	SCLK	Serial Clock Input. Data is clocked into the input shift register on the falling edge of SCLK. This input operates at clock speeds up to 30 MHz.
4	32	$\overline{\text{SYNC}}$	Frame Synchronization Input, Active Low. This is the frame synchronization signal for the serial interface. When $\overline{\text{SYNC}}$ is low, data is transferred on the falling edge of SCLK. The input shift register data is latched on the rising edge of $\overline{\text{SYNC}}$.
5	1	SDIN	Serial Data Input. Data must be valid on the falling edge of SCLK.
6	2	$\overline{\text{LDAC}}$	Load DAC Input, Active Low. This pin is used to update the DAC register and, consequently, the output current. If $\overline{\text{LDAC}}$ is tied permanently low, the DAC register is updated on the rising edge of $\overline{\text{SYNC}}$. If $\overline{\text{LDAC}}$ is held high during the write cycle, the input register is updated, but the output update is delayed until the falling edge of $\overline{\text{LDAC}}$. The $\overline{\text{LDAC}}$ pin should not be left unconnected.
7	3	FAULT	Fault Alert Output Pin, Active High. This pin is asserted high when a fault is detected. Detectable faults are loss of SPI interface control, communication error (PEC), loop current out of range, insufficient loop voltage, and overtemperature. For more information, see the Fault Alerts section.
8	5	DV _{DD}	3.3 V Digital Power Supply Output. This pin should be decoupled to COM with 100 nF and 4.7 μ F capacitors.
9	6	ALARM_CURRENT_DIRECTION	Alarm Current Direction Select. This pin is used to select whether the alarm current is upscale (22.8 mA/24 mA) or downscale (3.2 mA). Connecting this pin to DV _{DD} selects an upscale alarm current (22.8 mA/24 mA); connecting this pin to COM selects a downscale alarm current (3.2 mA). For more information, see the Power-On Default section.
10	7	R _{INT} /R _{EXT}	Current Setting Resistor Select. When this pin is connected to DV _{DD} , the internal current setting resistor is selected. When this pin is connected to COM, the external current setting resistor is selected. An external resistor can be connected between the R _{EXT1} and R _{EXT2} pins.
11, 12	8, 10	RANGE0, RANGE1	Digital Input Pins. These two pins select the loop current range (see the Loop Current Range Selection section).

Pin No.		Mnemonic	Description
TSSOP	LFCSP		
13, 14	4, 11, 12	COM	Ground Reference Pin for the AD5421. It is recommended that a 4.7 V Zener diode be placed between the LOOP– and COM pins. See the Applications Information section for more information.
15, 16, 17	13, 14, 15	REG_SEL2, REG_SEL1, REG_SEL0	These three pins together select the regulator output (REG _{OUT}) voltage (see the Voltage Regulator section).
18	17	REFIN	Reference Voltage Input. V _{REFIN} = 2.5 V for specified performance.
19	18	REFOUT2	Internal Reference Voltage Output (1.22 V). It is recommended to connect a 100 nF capacitor from this pin to COM.
20	19	REFOUT1	Internal Reference Voltage Output (2.5 V). It is recommended to connect a 100 nF capacitor from this pin to COM.
21	20	C _{IN}	External Capacitor Connection and HART FSK Input. An external capacitor connected from C _{IN} to COM implements an output slew rate control function (see the Loop Current Slew Rate Control section). HART FSK signaling can also be coupled through a capacitor to this pin (see the HART Communications section).
22, 23	21, 22	R _{EXT1} , R _{EXT2}	Connection for External Current Setting Resistor. A precision 24 kΩ resistor can be connected between these pins for improved performance.
24	23	LOOP–	Loop Current Return Pin. As shown in Figure 1, the COM and LOOP– pins can be used to sense the loop current across the internal 52 Ω resistor. Note that the voltage measured at LOOP– will be negative with respect to COM.
25	23	V _{LOOP}	Voltage Input Pin. Voltage input range is 0 V to 2.5 V. The voltage applied to this pin is digitized to eight bits, which are available in the fault register. This pin can be used for general-purpose voltage monitoring, but it is intended for monitoring of the loop supply voltage. Connecting the loop voltage to this pin via a 20:1 resistor divider allows the AD5421 to monitor and feedback the loop voltage. The AD5421 also generates an alert if the loop voltage is close to the minimum operating value (see the Loop Voltage Fault section).
26	26	DRIVE	Gate Connection for External Depletion Mode MOSFET. For more information, see the Connection to Loop Power Supply section.
27	27	REG _{IN}	Voltage Regulator Input. The loop voltage can be connected directly to this pin. Or, to reduce on-chip power dissipation, an external pass transistor can be connected at this pin to stand off the loop voltage. For more information, see the Connection to Loop Power Supply section.
28	28	REG _{OUT}	Voltage Regulator Output. Pin selectable values are from 1.8 V to 12 V via the REG_SEL0, REG_SEL1, and REG_SEL2 pins (see the Voltage Regulator section). If REG _{OUT} is driving a microconverter supply (see Figure 50), this pin should be decoupled to COM with a >1 μF capacitor.
N/A ¹	9, 16, 25	NC	No Connect. Do not connect to this pin.
EPAD	EPAD	Exposed Pad	The exposed paddle should be connected to the same potential as the COM pin and to a copper plane for optimum thermal performance.

¹ N/A means not applicable.

TYPICAL PERFORMANCE CHARACTERISTICS

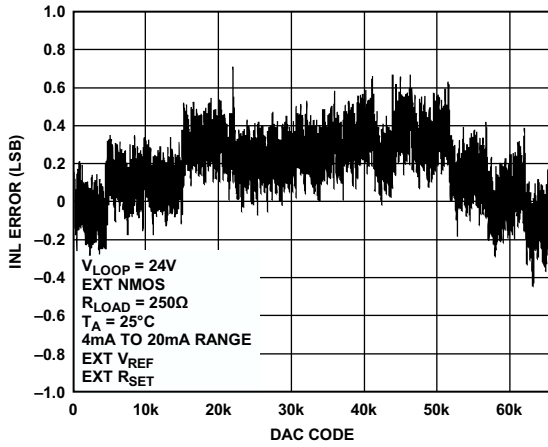

Figure 7. Integral Nonlinearity Error vs. Code

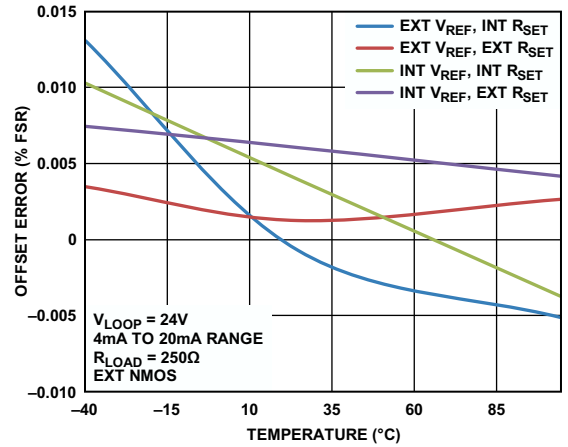

Figure 10. Offset Error vs. Temperature

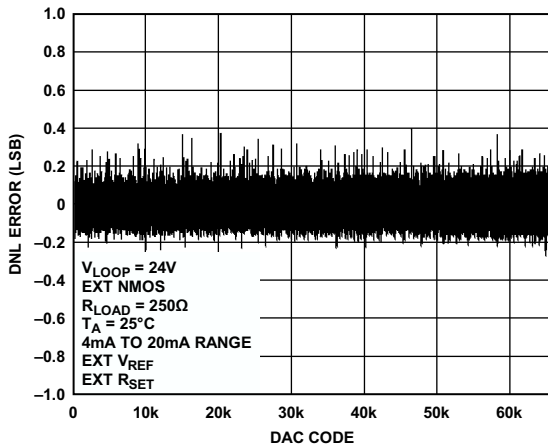

Figure 8. Differential Nonlinearity Error vs. Code

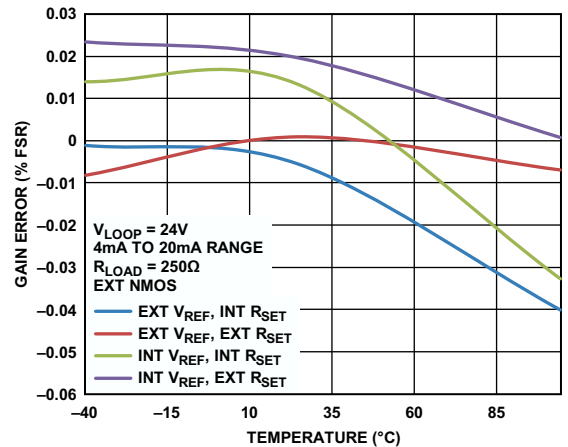

Figure 11. Gain Error vs. Temperature

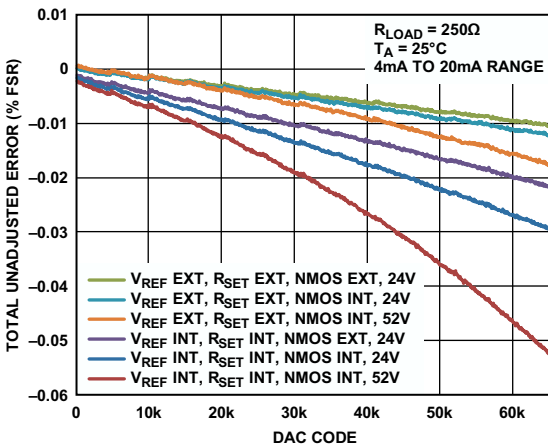

Figure 9. Total Unadjusted Error vs. Code

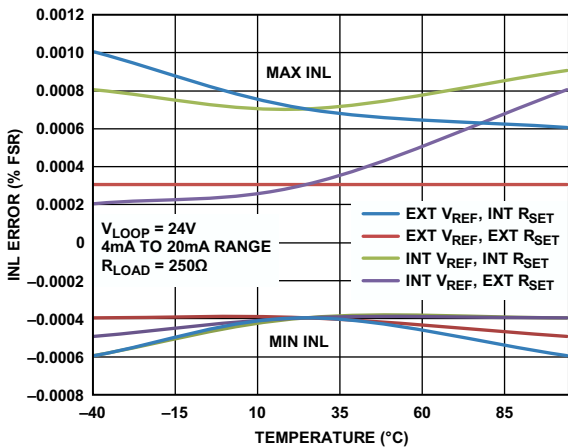

Figure 12. Integral Nonlinearity Error vs. Temperature

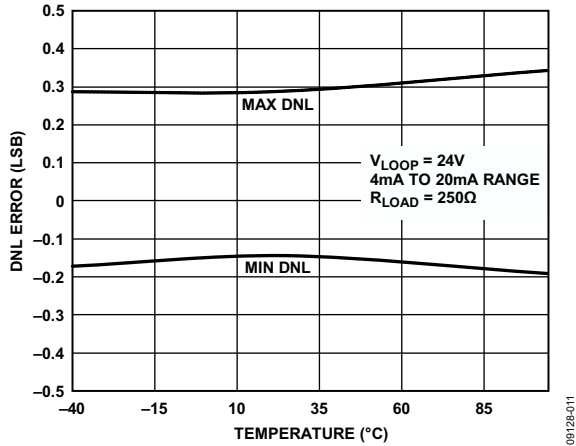

Figure 13. Differential Nonlinearity Error vs. Temperature

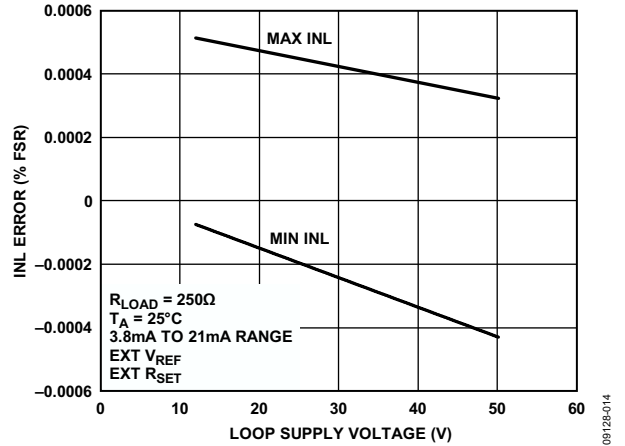

Figure 16. Integral Nonlinearity Error vs. Loop Supply Voltage

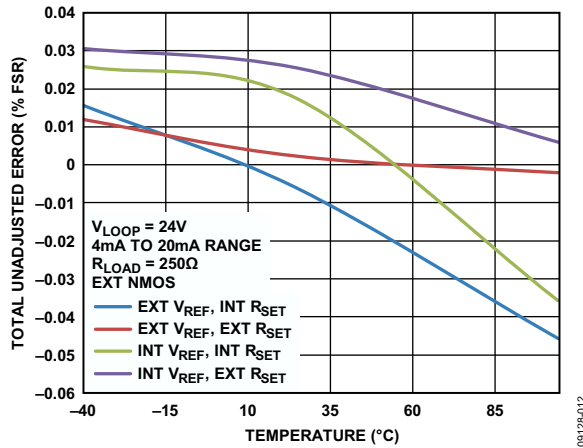

Figure 14. Total Unadjusted Error vs. Temperature

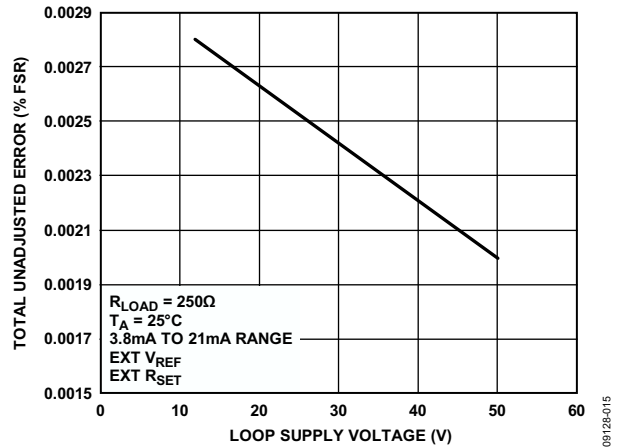

Figure 17. Total Unadjusted Error vs. Loop Supply Voltage

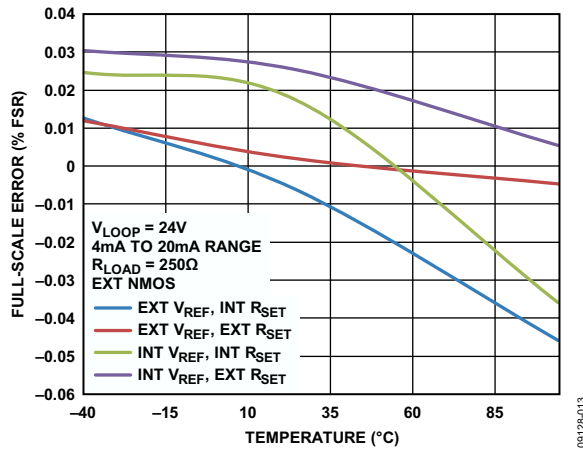

Figure 15. Full-Scale Error vs. Temperature

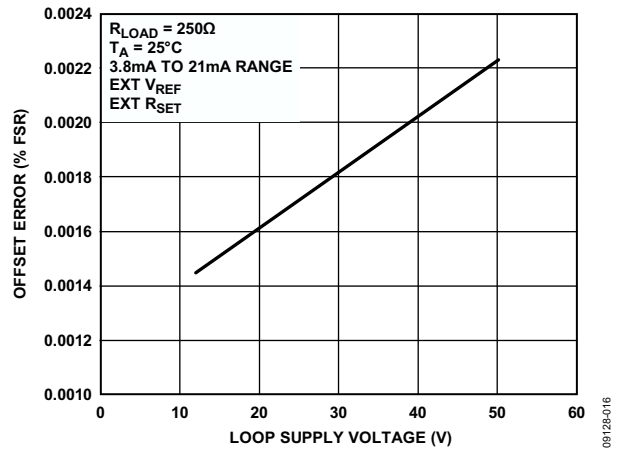

Figure 18. Offset Error vs. Loop Supply Voltage

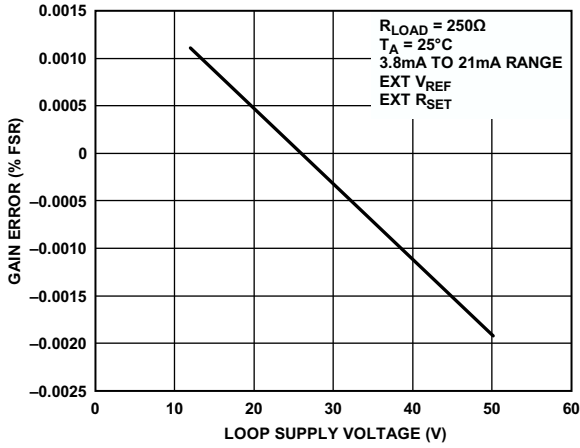

Figure 19. Gain Error vs. Loop Supply Voltage

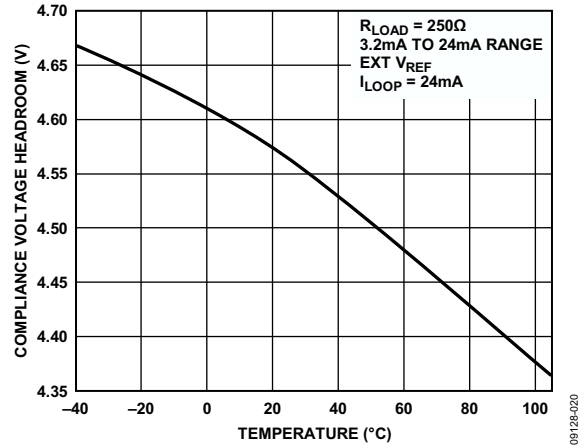

Figure 22. Compliance Voltage Headroom vs. Temperature

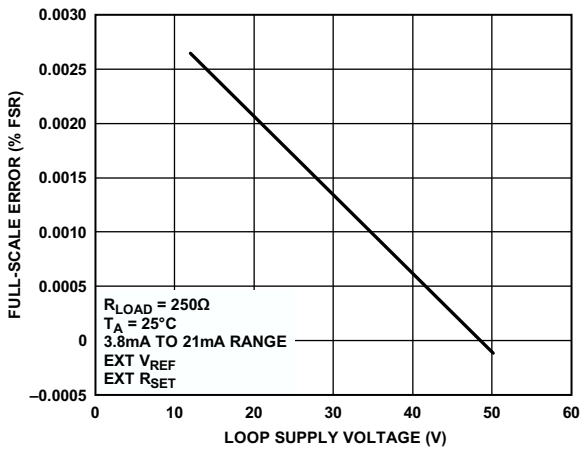

Figure 20. Full-Scale Error vs. Loop Supply Voltage

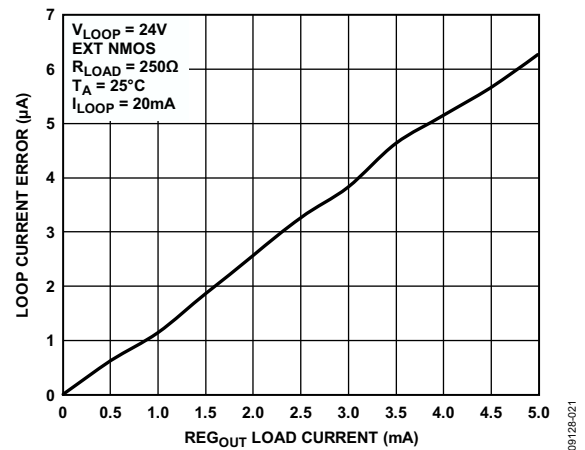

Figure 23. Loop Current Error vs. REG_{OUT} Load Current

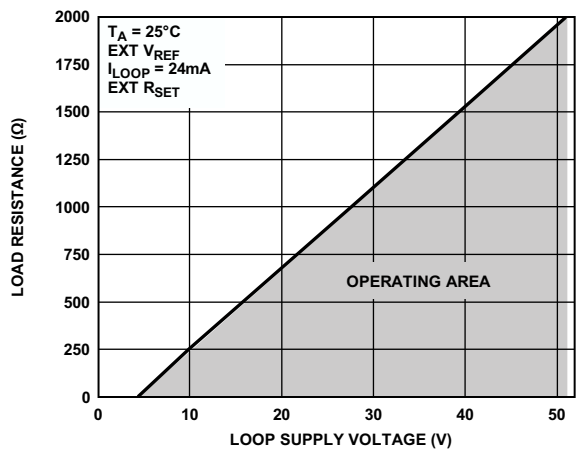

Figure 21. Load Resistance Load Line vs. Loop Supply Voltage (Voltage Between $LOOP-$ and REG_{IN})

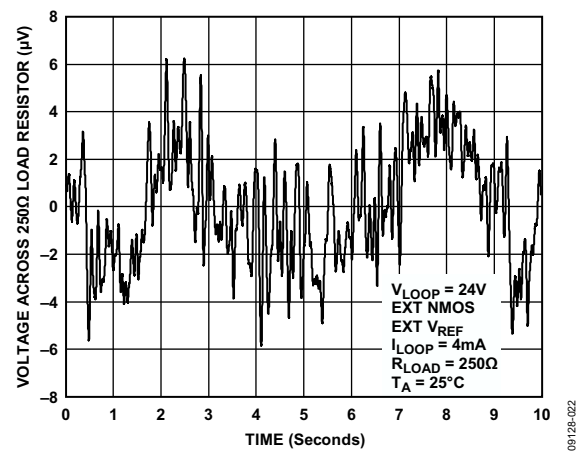

Figure 24. Loop Current Noise, 0.1 Hz to 10 Hz Bandwidth

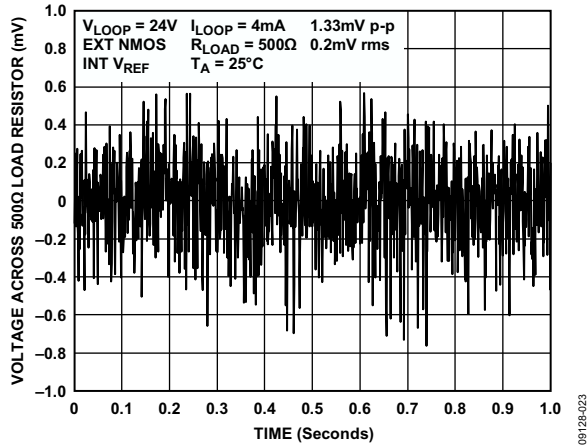

Figure 25. Loop Current Noise, 500 Hz to 10 kHz Bandwidth (HART Bandwidth)

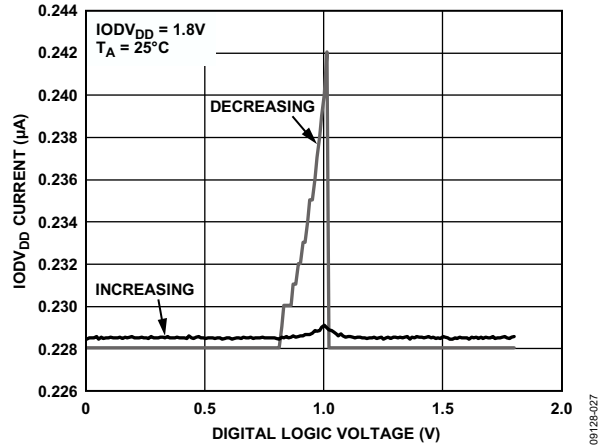

Figure 28. $I_{ODV_{DD}}$ Current vs. Digital Logic Voltage, Increasing and Decreasing, $I_{ODV_{DD}} = 1.8V$

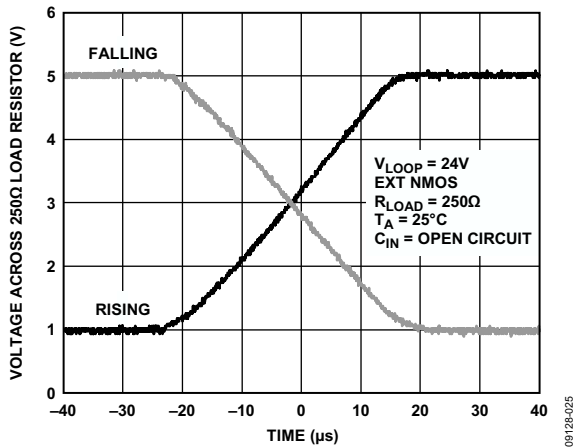

Figure 26. Full-Scale Loop Current Step

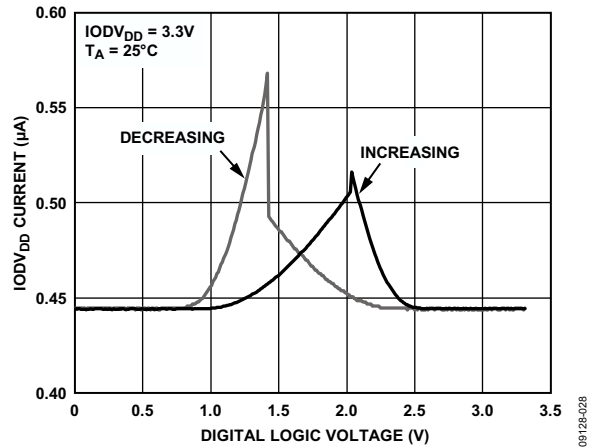

Figure 29. $I_{ODV_{DD}}$ Current vs. Digital Logic Voltage, Increasing and Decreasing, $I_{ODV_{DD}} = 3.3V$

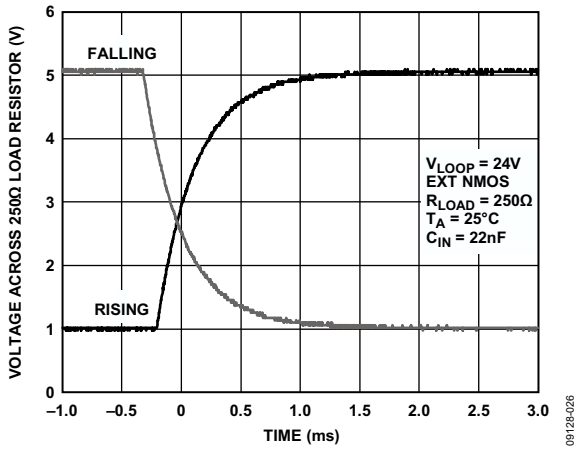

Figure 27. Full-Scale Loop Current Step, $C_{IN} = 22 nF$

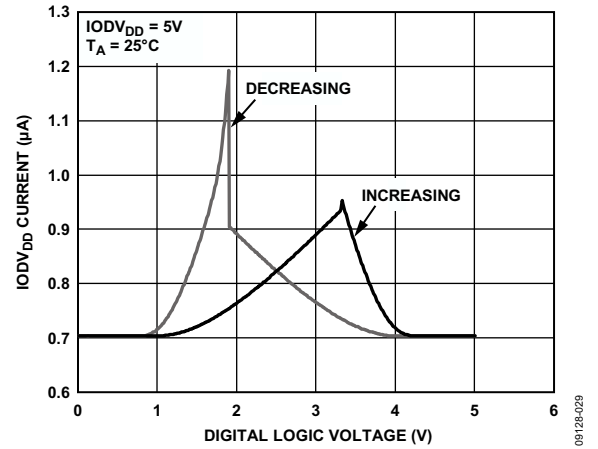

Figure 30. $I_{ODV_{DD}}$ Current vs. Digital Logic Voltage, Increasing and Decreasing, $I_{ODV_{DD}} = 5V$

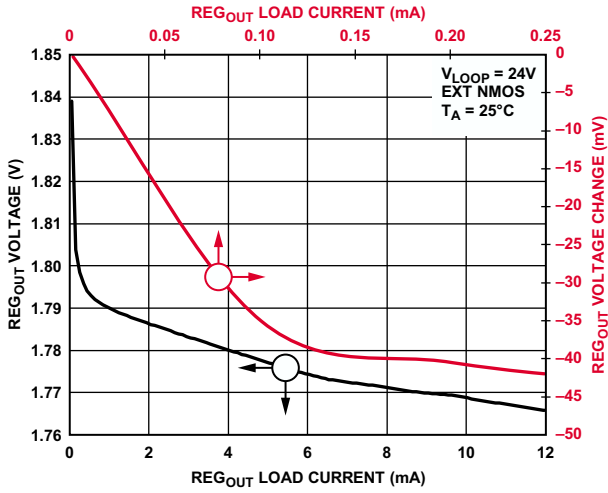

Figure 31. REG_{OUT} Voltage vs. Load Current

09128-030

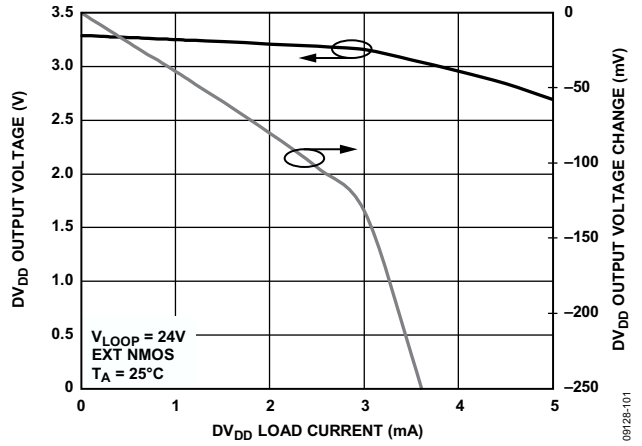

Figure 34. DV_{DD} Output Voltage vs. Load Current

09128-101

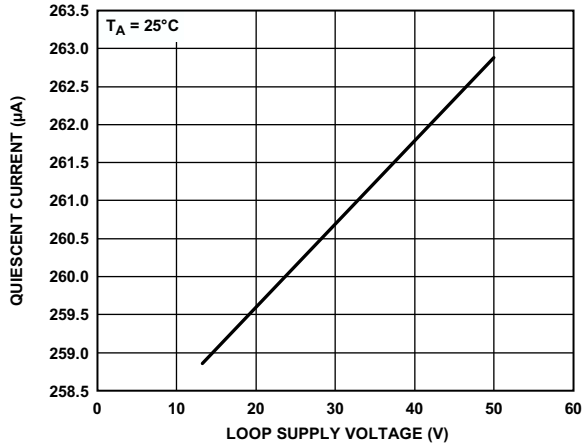

Figure 32. Quiescent Current vs. Loop Supply Voltage

09128-031

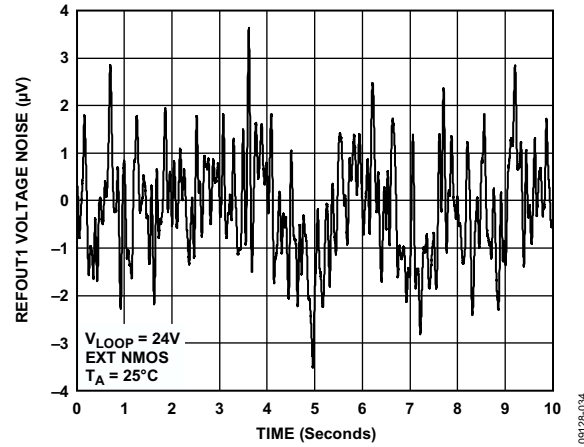

Figure 35. REFOUT1 Voltage Noise, 0.1 Hz to 10 Hz Bandwidth

09128-034

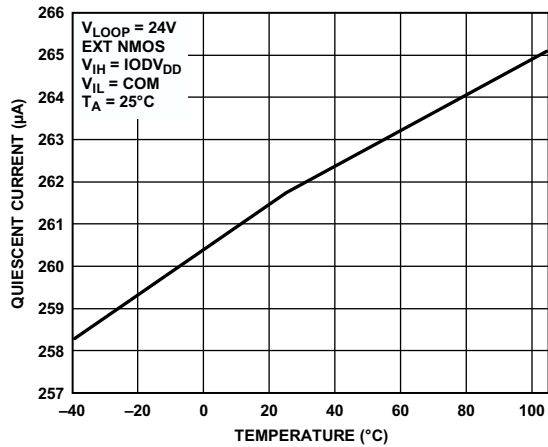

Figure 33. Quiescent Current vs. Temperature

09128-032

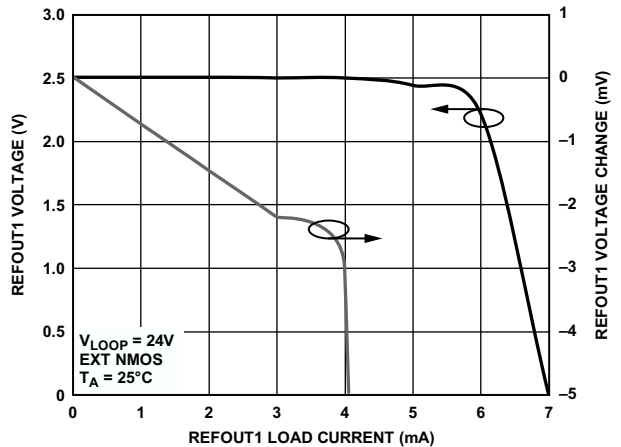

Figure 36. REFOUT1 Voltage vs. Load Current

09128-035

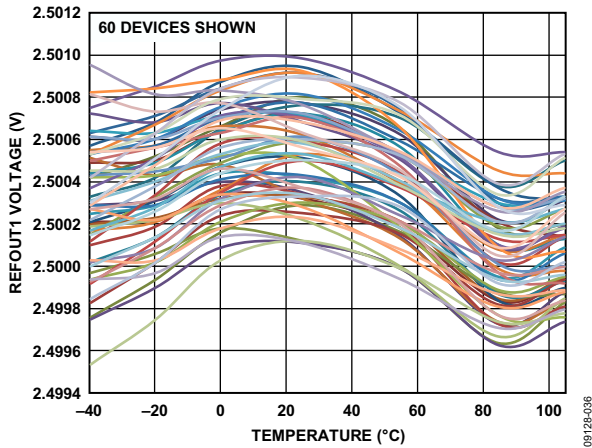

Figure 37. REFOUT1 Voltage vs. Temperature, 60 Devices Shown (C Grade Device)

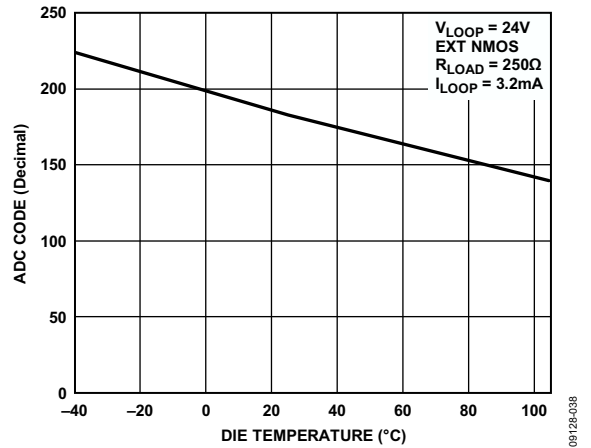

Figure 39. On-Chip ADC Code vs. Die Temperature

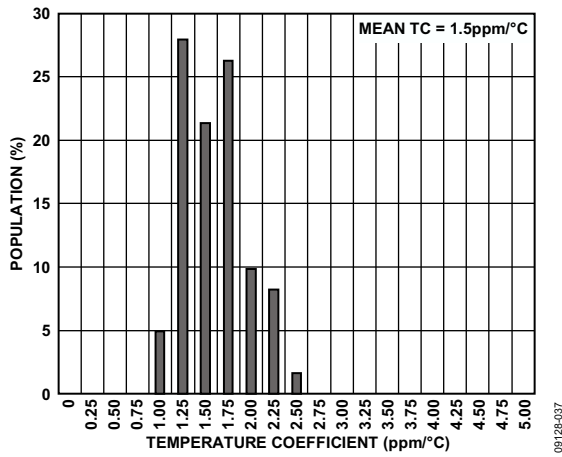

Figure 38. REFOUT1 Temperature Coefficient Histogram (C Grade Device)

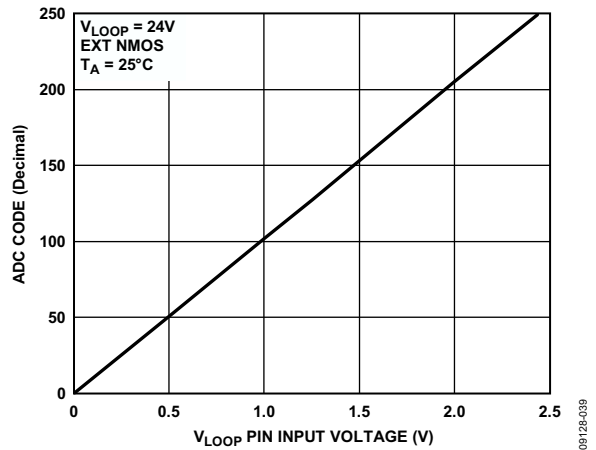

Figure 40. On-Chip ADC Code vs. V_{LOOP} Pin Input Voltage

TERMINOLOGY

Total Unadjusted Error

Total unadjusted error (TUE) is a measure of the total output error. TUE consists of INL error, offset error, gain error, and output drift over temperature, in the case of maximum TUE. TUE is expressed in % FSR.

Relative Accuracy or Integral Nonlinearity (INL) Error

Relative accuracy, or integral nonlinearity (INL) error, is a measure of the maximum deviation in the output current from a straight line passing through the endpoints of the transfer function. INL error is expressed in % FSR.

Differential Nonlinearity (DNL) Error

Differential nonlinearity (DNL) error is the difference between the measured change and the ideal 1 LSB change between any two adjacent codes. A specified differential nonlinearity of ± 1 LSB maximum ensures monotonicity.

Offset Error

Offset error is a measure of the output error when zero code is loaded to the DAC register and is expressed in % FSR.

Offset Error Temperature Coefficient (TC)

Offset error TC is a measure of the change in offset error with changes in temperature and is expressed in ppm FSR/°C.

Gain Error

Gain error is a measure of the span error of the DAC. It is the deviation in slope of the DAC transfer function from the ideal and is expressed in % FSR.

Gain Error Temperature Coefficient (TC)

Gain error TC is a measure of the change in gain error with changes in temperature and is expressed in ppm FSR/°C.

Full-Scale Error

Full-scale error is a measure of the output error when full-scale code is loaded to the DAC register and is expressed in % FSR.

Full-Scale Error Temperature Coefficient (TC)

Full-scale error TC is a measure of the change in full-scale error with changes in temperature and is expressed in ppm FSR/°C.

Loop Compliance Voltage Headroom

Loop compliance voltage headroom is the minimum voltage between the LOOP– and REG_{IN} pins for which the output current is equal to the programmed value.

Output Temperature Coefficient (TC)

Output TC is a measure of the change in the output current at 12 mA with changes in temperature and is expressed in ppm FSR/°C.

Voltage Reference Thermal Hysteresis

Voltage reference thermal hysteresis is the difference in output voltage measured at +25°C compared to the output voltage measured at +25°C after cycling the temperature from +25°C to –40°C to +105°C and back to +25°C. The hysteresis is specified for the first and second temperature cycles and is expressed in mV.

Voltage Reference Temperature Coefficient (TC)

Voltage reference TC is a measure of the change in the reference output voltage with a change in temperature. The voltage reference TC is calculated using the box method, which defines the TC as the maximum change in the reference output voltage over a given temperature range. Voltage reference TC is expressed in ppm/°C as follows:

$$TC = \left(\frac{V_{REF_MAX} - V_{REF_MIN}}{V_{REF_NOM} \times Temp_Range} \right) \times 10^6$$

where:

V_{REF_MAX} is the maximum reference output voltage measured over the total temperature range.

V_{REF_MIN} is the minimum reference output voltage measured over the total temperature range.

V_{REF_NOM} is the nominal reference output voltage, 2.5 V.

$Temp_Range$ is the specified temperature range (–40°C to +105°C).

THEORY OF OPERATION

The AD5421 is an integrated device designed for use in loop-powered, 4 mA to 20 mA smart transmitter applications. In a single chip, the AD5421 provides a 16-bit DAC and current amplifier for digital control of the loop current, a voltage regulator to power the entire transmitter, a voltage regulator for power the entire transmitter, a voltage regulator, fault alert functions, a flexible SPI-compatible serial interface, gain and offset adjust registers, as well as other features and functions. The features of the AD5421 are described in the following sections.

FAULT ALERTS

The AD5421 provides a number of fault alert features. All faults are signaled to the controller via the FAULT pin and the fault register. In the case of a loss of communication between the AD5421 and the microcontroller (SPI fault), the AD5421 programs the loop current to an alarm value. If the controller detects that the FAULT pin is set high, it should then read the fault register to determine the cause of the fault. Note that the watchdog timer does not reset and restart its condition with an alarm active. If the auto fault readback is disabled and an SPI fault occurs, such that the watchdog timer is timed out, the watchdog timer remains inactive until the status register is manually read back by the user. Following this readback, the watchdog timer resumes operation.

SPI Fault

The SPI fault is asserted if there is no valid communication to any register of the AD5421 for more than a user-defined period. The user can program the time period using the SPI watchdog timeout bits of the control register. The SPI fault bit of the fault register indicates the fault on the SPI bus. Because this fault is caused by a loss of communication between the controller and the AD5421, the loop current is also forced to the alarm value.

The direction of the alarm current (downscale or upscale) is selected via the ALARM_CURRENT_DIRECTION pin. Connecting this pin to DV_{DD} selects an upscale alarm current (22.8 mA/24 mA); connecting this pin to COM selects a downscale alarm current (3.2 mA).

Packet Error Checking

To verify that data has been received correctly in noisy environments, the AD5421 offers the option of error checking based on an 8-bit cyclic redundancy check (CRC). Packet error checking (PEC) is enabled by writing to the AD5421 with a 32-bit serial frame, where the least significant eight bits are the frame check sequence (FCS). The device controlling the AD5421 should generate the 8-bit FCS using the following polynomial:

$$C(x) = x^8 + x^2 + x + 1$$

The 8-bit FCS is appended to the end of the data-word, and 32 data bits are sent to the AD5421 before SYNC is taken high. If the check is valid, the data is accepted. If the check fails, the FAULT pin is asserted and the PEC bit of the fault register is set.

After the fault register is read, the PEC bit is reset low and the FAULT pin returns low.

In the case of data readback, if the AD5421 is addressed with a 32-bit frame, it generates the 8-bit frame check sequence and appends it to the end of the 24-bit data stream to create a 32-bit data stream.

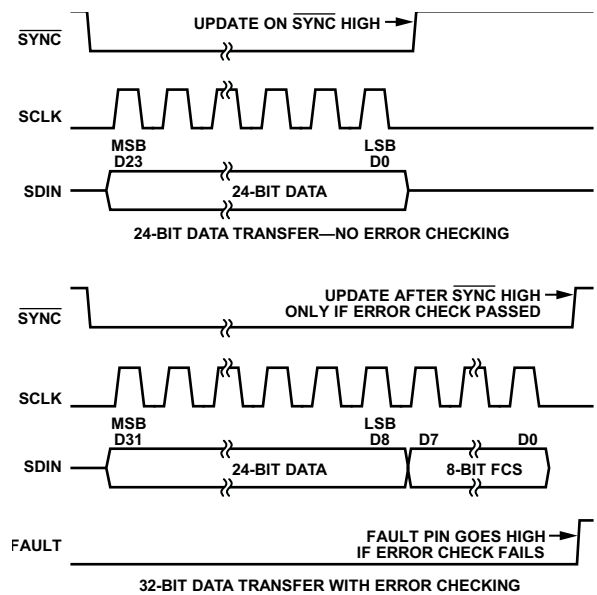

Figure 41. PEC Timing

Current Loop Fault

The current loop (I_{LOOP}) fault is asserted when the actual loop current is not within $\pm 0.01\%$ FSR of the programmed loop current. If the measured loop current is less than the programmed loop current, the I_{LOOP} Under bit of the fault register is set. If the measured loop current is greater than the programmed loop current, the I_{LOOP} Over bit of the fault register is set. The FAULT pin is set to logic high in either case.

An I_{LOOP} Over condition occurs when the value of the load current sourced from the AD5421 (via REG_{OUT}, REFOUT1, REFOUT2, or DV_{DD}) is greater than the loop current that is programmed to flow in the loop. An I_{LOOP} under condition occurs when there is insufficient compliance voltage to support the programmed loop current, caused by excessive load resistance or low loop supply voltage.

Overtemperature Fault

There are two overtemperature alert bits in the fault register: Temp 100°C and Temp 140°C. If the die temperature of the AD5421 exceeds either 100°C or 140°C, the appropriate bit is set. If the Temp 140°C bit is set in the fault register, the FAULT pin is set to logic high.

Loop Voltage Fault

There are two loop voltage alert bits in the fault register: V_{LOOP} 12V and V_{LOOP} 6V. If the voltage between the V_{LOOP} and COM pins falls below 0.6 V (corresponding to a 12 V loop supply value), the V_{LOOP} 12V bit is set; this bit is cleared when the voltage returns above 0.7 V. Similarly, if the voltage between the V_{LOOP} and COM pins falls below 0.3 V (corresponding to a 6 V loop supply value), the V_{LOOP} 6V bit is set; this bit is cleared when the voltage returns above 0.4 V. If the V_{LOOP} 6V bit is set in the fault register, the FAULT pin is set to logic high.

Figure 42 illustrates how a resistor divider enables the monitoring of the loop supply with the V_{LOOP} input. The recommended resistor divider consists of a 1 M Ω and a 19 M Ω resistor that provide a 20:1 ratio, allowing the 2.5 V input range of the V_{LOOP} pin to monitor loop supplies up to 50 V. With a 20:1 divider ratio, the preset V_{LOOP} 6V and V_{LOOP} 12V alert bits of the fault register generate loop supply faults according to their stated values. If another divider ratio is used, the fault bits generate faults at values that are not equal to 6 V and 12 V.

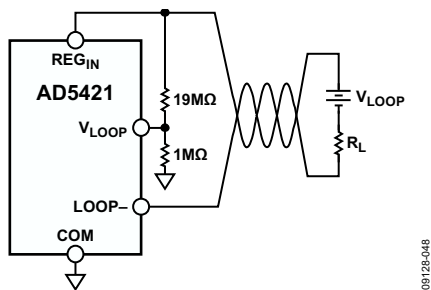

Figure 42. Resistor Divider Connection at V_{LOOP} Pin

EXTERNAL CURRENT SETTING RESISTOR

The 24 k Ω resistor R_{SET} , shown in Figure 1, converts the DAC output voltage to a current, which is then mirrored with a gain of 221 to the LOOP- pin. The stability of the loop current over temperature is dependent on the temperature coefficient of R_{SET} .

Table 1 and Table 2 outline the performance specifications of the AD5421 with both the internal R_{SET} resistor and an external, 24 k Ω R_{SET} resistor. Using the internal R_{SET} resistor, a total unadjusted error of better than 0.126% FSR can be expected. Using an external resistor gives improved performance of 0.048% FSR. This specification assumes an ideal resistor; the actual performance depends on the absolute value and temperature coefficient of the resistor used. For more information, see the Determining the Expected Total Error section.

LOOP CURRENT RANGE SELECTION

To select the loop current range, connect the RANGE0 and RANGE1 pins to the COM and DV_{DD} pins, as shown in Table 9.

Table 9. Selecting the Loop Current Range

RANGE1 Pin	RANGE0 Pin	Loop Current Range
COM	COM	4 mA to 20 mA
COM	DV_{DD}	3.8 mA to 21 mA
DV_{DD}	COM	3.2 mA to 24 mA
DV_{DD}	DV_{DD}	3.8 mA to 21 mA

CONNECTION TO LOOP POWER SUPPLY

The AD5421 is powered from the 4 mA to 20 mA current loop. Typically, the power supply is located far from the transmitter device and has a value of 24 V. The AD5421 can be connected directly to the loop power supply and can tolerate a voltage up to a maximum of 52 V (see Figure 43).

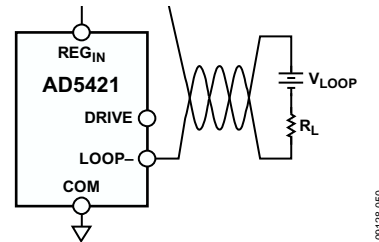

Figure 43. Direct Connection of the AD5421 to Loop Power Supply

Figure 43 shows how the AD5421 is connected directly to the loop power supply. An alternative power connection is shown in Figure 44, which shows a depletion mode N-channel MOSFET connected between the AD5421 and the loop power supply. The use of this device keeps the voltage drop across the AD5421 at approximately 12 V, limiting the worst-case on-chip power dissipation to 288 mW (12 V \times 24 mA = 288 mW). If the AD5421 is connected directly to the loop supply as shown in Figure 43, the potential worst-case on-chip power dissipation for a 24 V loop power supply is 576 mW (24 V \times 24 mA = 576 mW). The power dissipation changes in proportion to the loop power supply voltage.

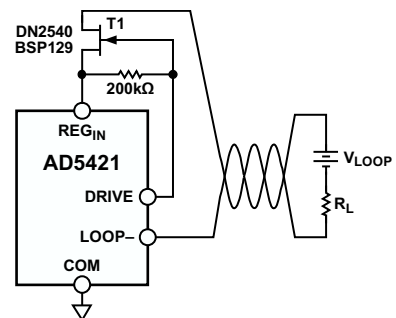

Figure 44. MOSFET Connecting the AD5421 to Loop Power Supply

ON-CHIP ADC

The AD5421 contains an on-chip ADC used to measure and feed back to the fault register either the temperature of the die or the voltage between the V_{LOOP} and COM pins. The select ADC input bit (Bit D8) of the control register selects the parameter to be converted. A conversion is initiated with command byte 00001000 (necessary only if auto fault readback is disabled). This command byte powers on the ADC and performs the conversion. A read of the fault register returns the conversion result. If auto readback of the fault register is required, the ADC must first be powered up by setting the on-chip ADC bit (Bit D7) of the control register.

Because the FAULT pin can go high for as long as 30 μs, care is required when performing a die temperature measurement after a readback of the V_{LOOP} voltage. When switching from a V_{LOOP} measurement to a die temperature measurement, the FAULT pin should not be read within 30 μs of switching, as a false trigger may occur (fault register contents are unaffected).

VOLTAGE REGULATOR

The on-chip voltage regulator provides a regulated voltage output to supply the AD5421 and the remainder of the transmitter circuitry. The output voltage range is from 1.8 V to 12 V and is selected by the states of three digital input pins (see Table 10). The regulator output is accessed at the REG_{OUT} pin.

Table 10. Setting the Voltage Regulator Output

REG_SEL2	REG_SEL1	REG_SELO	Regulated Output Voltage (V)
COM	COM	COM	1.8
COM	COM	DV _{DD}	2.5
COM	DV _{DD}	COM	3.0
COM	DV _{DD}	DV _{DD}	3.3
DV _{DD}	COM	COM	5.0
DV _{DD}	COM	DV _{DD}	9.0
DV _{DD}	DV _{DD}	COM	12.0

LOOP CURRENT SLEW RATE CONTROL

The rate of change of the loop current can be controlled by connecting an external capacitor between the C_{IN} pin and COM. This reduces the rate of change of the loop current. The output resistance of the DAC (R_{DAC}) together with the C_{SLEW} capacitor generate a time constant that determines the response of the loop current (see Figure 45).

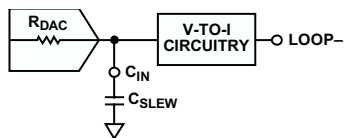

Figure 45. Slew Capacitor Circuit

The resistance of the DAC is typically 15.22 kΩ for the 4 mA to 20 mA and 3.8 mA to 21 mA loop current ranges. The DAC resistance changes to 16.11 kΩ when the 3.2 mA to 24 mA loop current range is selected.

The time constant of the circuit is expressed as

$$\tau = R_{DAC} \times C_{SLEW}$$

Taking five time constants as the required time to reach the final value, C_{SLEW} can be determined for a desired response time, t, as follows:

$$C_{SLEW} = \frac{t}{5 \times R_{DAC}}$$

where:

t is the desired time for the output current to reach its final value.

R_{DAC} is the resistance of the DAC core, either 15.22 kΩ or 16.11 kΩ, depending on the selected loop current range.

For a response time of 5 ms,

$$C_{SLEW} = \frac{5 \text{ ms}}{5 \times 15,220} \approx 68 \text{ nF}$$

For a response time of 10 ms,

$$C_{SLEW} = \frac{10 \text{ ms}}{5 \times 15,220} \approx 133 \text{ nF}$$

The responses for both of these configurations are shown in Figure 46.

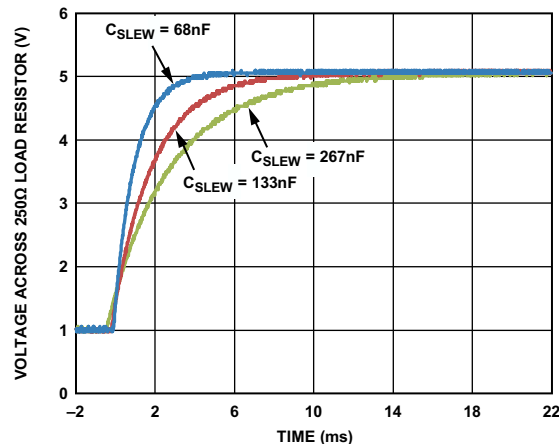

Figure 46. 4 mA to 20 mA Step with Slew Rate Control

The C_{IN} pin can also be used as a coupling input for HART FSK signaling. The HART signal must be ac-coupled to the C_{IN} input. The capacitor through which the HART signal is coupled must be considered in the preceding calculations, where the total capacitance is C_{SLEW} + C_{HART}. For more information, see the HART Communications section.

POWER-ON DEFAULT

The AD5421 powers on with all registers loaded with their default values and with the loop current in the alarm state set to 3.2 mA or 22.8 mA/24 mA (depending on the state of the ALARM_CURRENT_DIRECTION pin and the selected range). The AD5421 remains in this state until it is programmed with new values. The SPI watchdog timer is enabled by default with a timeout period of 1 sec. If there is no communication with the AD5421 within 1 sec of power-on, the FAULT pin is set.

Table 11.

Range	ALARM_CURRENT_DIRECTION	Power-On Loop Current (mA)
4 mA to 20 mA	0	3.2
4 mA to 20 mA	1	22.8
3.8 mA to 21 mA	0	3.2
3.8 mA to 21 mA	1	22.8
3.2 mA to 24 mA	0	3.2
3.2 mA to 24 mA	1	24

HART COMMUNICATIONS

The AD5421 can be interfaced to a Highway Addressable Remote Transducer (HART) modem to enable HART digital communications over the 2-wire loop connection. Figure 47 shows how the modem frequency shift keying (FSK) output is connected to the AD5421.

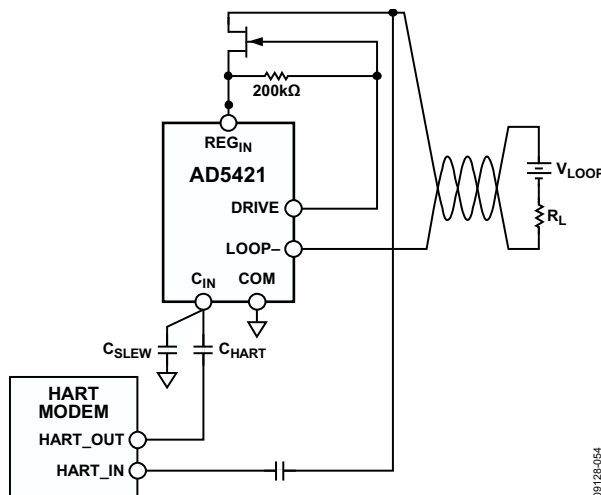

Figure 47. Connecting a HART Modem to the AD5421

To achieve a 1 mA p-p FSK current signal on the loop, the voltage at the C_{IN} pin must be 111 mV p-p. Assuming a 500 mV p-p output from the HART modem, this means that the signal must be attenuated by a factor of 4.5. The following equation can be used to calculate the values of the C_{HART} and C_{SLEW} capacitors.

$$4.5 = \frac{C_{HART} + C_{SLEW}}{C_{HART}}$$

From this equation, the ratio of C_{HART} to C_{SLEW} is 1 to 3.5. This ratio of the capacitor values sets the amplitude of the HART FSK signal on the loop. The absolute values of the capacitors set the response time of the loop current, as well as the bandwidth presented to the HART signal connected at the C_{IN} pin. The bandwidth must pass frequencies from 500 Hz to 10 kHz. The two capacitors and the internal impedance, R_{DAC}, form a high-pass filter. The 3 dB frequency of this high-pass filter should be less than 500 Hz and can be calculated as follows:

$$f_{3dB} = \frac{1}{2 \times \pi \times R_{DAC} \times (C_{HART} + C_{SLEW})}$$

To achieve a 500 Hz high-pass 3 dB frequency cutoff, the combined values of C_{HART} and C_{SLEW} should be 21 nF. To ensure the correct HART signal amplitude on the current loop, the final values for the capacitors are C_{HART} = 4.7 nF and C_{SLEW} = 16.3 nF.

Output Noise During Silence and Analog Rate of Change

The AD5421 has a direct influence on two important specifications relating to the HART communications protocol: output noise during silence and analog rate of change. Figure 25 shows the measurement of the AD5421 output noise in the HART extended bandwidth; the noise measurement is 0.2 mV rms, within the required 2.2 mV rms value.

To meet the analog rate of change specification, the rate of change of the 4 mA to 20 mA current must be slow enough so that it does not interfere with the HART digital signaling. This is determined by forcing a full-scale loop current change through a 500 Ω load resistor and applying the resulting voltage signal to the HART digital filter (HCF_TOOL-31). The peak amplitude of the signal at the filter output must be less than 150 mV. To achieve this, the rate of change of the loop current must be restricted to less than approximately 1.3 mA/ms.

The output of the AD5421 naturally slews at approximately 880 mA/ms, a rate that is far too great to comply with the HART specifications. To reduce the slew rate, a capacitor can be connected from the C_{IN} pin to COM, as described in the Loop Current Slew Rate Control section. To reduce the slew rate enough so that the HART specification is met, a capacitor value in the region of 4.7 μF is required, resulting in a full-scale transition time of 500 ms. Many applications regard this time as too slow, in which case the slew rate needs to be digitally controlled by writing a sequence of codes to the DAC register so that the output response follows the desired curve.

Figure 48 shows a digitally controlled full-scale step and the resulting filter output. In Figure 48, it can be seen that the peak amplitude of the filter output signal is less than the required 150 mV, and the transition time is approximately 30 ms.

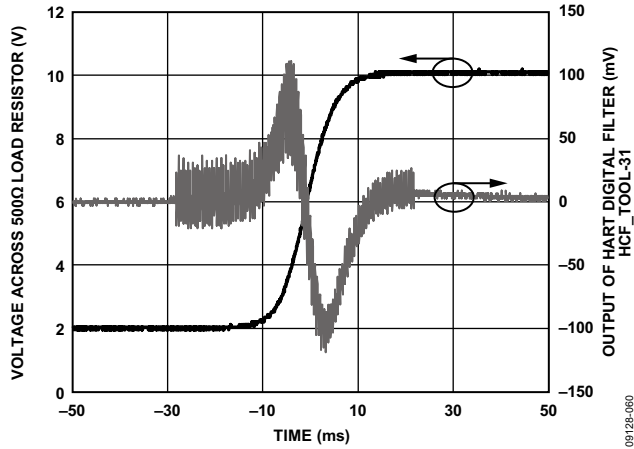

Figure 48. Digitally Controlled Full-Scale Step and Resulting HART Digital Filter Output Signal

Figure 49 shows the circuit diagram for this measurement. The 47 nF and 168 nF capacitor values for C_{HART} and C_{SLEW} provide adequate filtering of the digital steps, ensuring that they do not cause interference.

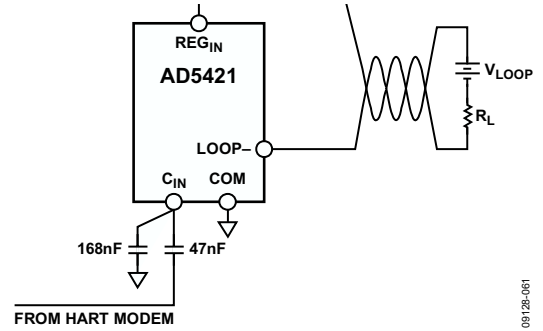

Figure 49. Circuit Diagram for Figure 48

SERIAL INTERFACE

The AD5421 is controlled by a versatile, 3-wire serial interface that operates at clock rates up to 30 MHz. It is compatible with the SPI, QSPI™, MICROWIRE®, and DSP standards. Figure 2 shows the timing diagram. The interface operates with either a continuous or noncontinuous gated burst clock.

The write sequence begins with a falling edge of the $\overline{\text{SYNC}}$ signal; data is clocked in on the SDIN data line on the falling edge of SCLK. On the rising edge of $\overline{\text{SYNC}}$, the 24 bits of data are latched; the data is transferred to the addressed register and the programmed function is executed (either a change in DAC output or mode of operation).

If packet error checking on the SPI interface is required using cyclic redundancy codes, an additional eight bits must be written to the AD5421, creating a 32-bit serial interface. In this case, 32 bits are written to the AD5421 before $\overline{\text{SYNC}}$ is brought high.

INPUT SHIFT REGISTER

The input shift register is 24 bits wide (32 bits wide if CRC error checking of the data is required). Data is loaded into the device MSB first as a 24-/32-bit word under the control of a serial clock input, SCLK. The input shift register consists of an 8-bit address/command byte, a 16-bit data-word, and an optional 8-bit CRC, as shown in Table 13 and Table 14.

The address/command byte decoding is described in Table 12.

Table 12. Address/Command Byte Functions

Address/Command Byte	Function
00000001	Write to DAC register
00000010	Write to control register

Table 13. Input Shift Register

MSB																LSB							
D23	D22	D21	D20	D19	D18	D17	D16	D15	D14	D13	D12	D11	D10	D9	D8	D7	D6	D5	D4	D3	D2	D1	D0
Address/command byte								Data-word															

Table 14. Input Shift Register with CRC

MSB																				LSB											
D31	D30	D29	D28	D27	D26	D25	D24	D23	D22	D21	D20	D19	D18	D17	D16	D15	D14	D13	D12	D11	D10	D9	D8	D7	D6	D5	D4	D3	D2	D1	D0
Address/command byte								Data-word																CRC							

Address/Command Byte	Function
00000011	Write to offset adjust register
00000100	Write to gain adjust register
00000101	Load DAC
00000110	Force alarm current
00000111	Reset (it is recommended to wait 50 μs after a device reset before writing the next command)
00001000	Initiate V_{LOOP} /temperature measurement
00001001	No operation
10000001	Read DAC register
10000010	Read control register
10000011	Read offset adjust register
10000100	Read gain adjust register
10000101	Read fault register

The 16 bits of the data-word written following a load DAC, force alarm current, reset, initiate V_{LOOP} /temperature measurement, or no operation command byte are don't cares (see Table 13 and Table 14).

REGISTER READBACK

To read back a register, Bit D11 of the control register must be set to Logic 1 to disable the automatic readback of the fault register. The 16 bits of the data-word written following a read command are don't cares (see Table 13 and Table 14).

The register data addressed by the read command is clocked out of SDO on the subsequent write command (see Figure 3).

DAC REGISTER

The DAC register is a read/write register and is addressed as described in Table 12. The data programmed to the DAC register determines the loop current, as shown in the Ideal Output Transfer Function section and in Table 16.

Ideal Output Transfer Function

The transfer function describing the relationship between the data programmed to the DAC register and the loop current is expressed by the following three equations.

For the 4 mA to 20 mA output range, the loop current can be expressed as follows:

$$I_{LOOP} = \left(\frac{16 \text{ mA}}{2^{16}} \right) \times D + 4 \text{ mA}$$

For the 3.8 mA to 21 mA output range, the loop current can be expressed as follows:

$$I_{LOOP} = \left(\frac{17.2 \text{ mA}}{2^{16}} \right) \times D + 3.8 \text{ mA}$$

For the 3.2 mA to 24 mA output range, the loop current can be expressed as follows:

$$I_{LOOP} = \left(\frac{20.8 \text{ mA}}{2^{16}} \right) \times D + 3.2 \text{ mA}$$

where *D* is the decimal value of the DAC register.

Table 15. DAC Register Bit Map

MSB														LSB	
D15	D14	D13	D12	D11	D10	D9	D8	D7	D6	D5	D4	D3	D2	D1	D0
16-bit data															

Table 16. Relationship of DAC Register Code to Ideal Loop Current (Gain = 65,536; Offset = 0)

DAC Register Code	Ideal Loop Current (mA)		
	4 mA to 20 mA Range	3.8 mA to 21 mA Range	3.2 mA to 24 mA Range
0x0000	4	3.8	3.2
0x0001	4.00024	3.80026	3.2003
...
0x7FFF	11.9997	12.39974	13.5997
0x8000	12	12.4	13.6
...
0xFFFFE	19.9995	20.99947	23.9994
0xFFFFF	19.9997	20.99974	23.9997

CONTROL REGISTER

The control register is a read/write register and is addressed as described in Table 12. The data programmed to the control register determines the mode of operation of the AD5421.

Table 17. Control Register Bit Map

MSB											LSB				
D15	D14	D13	D12	D11	D10	D9	D8	D7	D6	D5	D4	D3	D2	D1	D0
SPI watchdog timeout			SPI watchdog timer	Auto fault readback	Alarm on SPI fault	Set min loop current	Select ADC input	On-chip ADC	Power down internal reference	V _{LOOP} fault alert	Reserved				
T0	T1	T2													

Table 18. Control Register Bit Descriptions

Control Bits	Description																																				
SPI watchdog timeout	The T0, T1, and T2 bits allow the user to program the watchdog timeout period. The watchdog timer is reset when a valid write to any AD5421 register occurs or when a NOP command is written.																																				
	<table border="1"> <thead> <tr> <th>T0</th> <th>T1</th> <th>T2</th> <th>Timeout Period</th> </tr> </thead> <tbody> <tr> <td>0</td> <td>0</td> <td>0</td> <td>50 ms</td> </tr> <tr> <td>0</td> <td>0</td> <td>1</td> <td>100 ms</td> </tr> <tr> <td>0</td> <td>1</td> <td>0</td> <td>500 ms</td> </tr> <tr> <td>0</td> <td>1</td> <td>1</td> <td>1 sec (default)</td> </tr> <tr> <td>1</td> <td>0</td> <td>0</td> <td>2 sec</td> </tr> <tr> <td>1</td> <td>0</td> <td>1</td> <td>3 sec</td> </tr> <tr> <td>1</td> <td>1</td> <td>0</td> <td>4 sec</td> </tr> <tr> <td>1</td> <td>1</td> <td>1</td> <td>5 sec</td> </tr> </tbody> </table>	T0	T1	T2	Timeout Period	0	0	0	50 ms	0	0	1	100 ms	0	1	0	500 ms	0	1	1	1 sec (default)	1	0	0	2 sec	1	0	1	3 sec	1	1	0	4 sec	1	1	1	5 sec
	T0	T1	T2	Timeout Period																																	
	0	0	0	50 ms																																	
	0	0	1	100 ms																																	
	0	1	0	500 ms																																	
	0	1	1	1 sec (default)																																	
	1	0	0	2 sec																																	
1	0	1	3 sec																																		
1	1	0	4 sec																																		
1	1	1	5 sec																																		
SPI watchdog timer	0 = SPI watchdog timer is enabled (default). 1 = SPI watchdog timer is disabled.																																				
Auto fault readback	This bit specifies whether the fault register contents are automatically clocked out on the SDO pin on each write operation. (The fault register can always be addressed for readback.) 0 = fault register contents are clocked out on the SDO pin (default). 1 = fault register contents are not clocked out on the SDO pin.																																				
Alarm on SPI fault	This bit specifies whether the loop current is forced to the alarm value when an SPI fault is detected (that is, the watchdog timer times out). When an SPI fault is detected, the SPI fault bit of the fault register and the FAULT pin are always set. 0 = loop current is forced to the alarm value when an SPI fault is detected (default). 1 = loop current is not forced to the alarm value when an SPI fault is detected.																																				
Set min loop current	0 = normal operation (default). 1 = loop current is set to its minimum value so that the total current flowing in the loop consists only of the operating current of the AD5421 and its associated circuitry.																																				
Select ADC input	0 = on-chip ADC measures the voltage between the V _{LOOP} and COM pins (default). 1 = on-chip ADC measures the temperature of the AD5421 die.																																				
On-chip ADC	0 = on-chip ADC is disabled (default). 1 = on-chip ADC is enabled.																																				
Power down internal reference	0 = internal voltage reference is powered up (default). 1 = internal voltage reference is powered down and an external voltage reference source is required.																																				
V _{LOOP} fault alert	This bit specifies whether the FAULT pin is set when the voltage between the V _{LOOP} and COM pins falls to approximately 0.3 V. (The V _{LOOP} 6V bit of the fault register is always set.) 0 = FAULT pin is not set when the V _{LOOP} – COM voltage falls to approximately 0.3 V. 1 = FAULT pin is set when the V _{LOOP} – COM voltage falls to approximately 0.3 V.																																				

FAULT REGISTER

The read-only fault register is addressed as described in Table 12. The bits in the fault register indicate a range of possible fault conditions.

Table 19. Fault Register Bit Map

MSB													LSB		
D15	D14	D13	D12	D11	D10	D9	D8	D7	D6	D5	D4	D3	D2	D1	D0
SPI	PEC	I _{LOOP} Over	I _{LOOP} Under	Temp 140°C	Temp 100°C	V _{LOOP} 6V	V _{LOOP} 12V	V _{LOOP} /temperature value							

Table 20. Fault Register Bit Descriptions

Fault Alert	FAULT Pin Set	Description												
SPI	Yes	This bit is set high to indicate the loss of the SPI interface signaling. This fault occurs if there is no valid communication to the AD5421 over the SPI interface for more than the user-defined timeout period. The occurrence of this fault also forces the loop current to the alarm value if Bit D10 of the control register is at Logic 0. The alarm current direction is determined by the state of the ALARM_CURRENT_DIRECTION pin.												
PEC (packet error check)	Yes	This bit is set high when an error in the SPI communication is detected using cyclic redundancy check (CRC) error detection. See the Packet Error Checking section for more information.												
I _{LOOP} Over	Yes	This bit is set high when the actual loop current is greater than the programmed loop current.												
I _{LOOP} Under	Yes	This bit is set high when the actual loop current is less than the programmed loop current.												
Temp 140°C	Yes	This bit is set high to indicate an overtemperature fault. This bit is set if the die temperature of the AD5421 exceeds approximately 140°C. This bit is cleared when the temperature returns below approximately 125°C.												
Temp 100°C	No	This bit is set high to indicate an increasing temperature of the AD5421. This bit is set if the die temperature of the AD5421 exceeds approximately 100°C. This bit is cleared when the temperature returns below approximately 85°C.												
V _{LOOP} 6V	Yes	This bit is set high when the voltage between the V _{LOOP} and COM pins falls below approximately 0.3 V (representing a 6 V loop supply voltage with 20:1 resistor divider connected at V _{LOOP}). This bit is cleared when the voltage returns above approximately 0.4 V.												
V _{LOOP} 12V	No	This bit is set high when the voltage between the V _{LOOP} and COM pins falls below approximately 0.6 V (representing a 12 V loop supply voltage with 20:1 resistor divider connected at V _{LOOP}). This bit is cleared when the voltage returns above approximately 0.7 V.												
V _{LOOP} /temperature value	N/A	These eight bits represent either the voltage between the V _{LOOP} and COM pins or the AD5421 die temperature, depending on the setting of Bit D8 of the control register (see the On-Chip ADC Transfer Function Equations section).												
		<table border="1"> <thead> <tr> <th>8-Bit Value</th> <th>V_{LOOP} – COM Voltage (V)</th> <th>Die Temperature (°C)</th> </tr> </thead> <tbody> <tr> <td>00000000</td> <td>0</td> <td>+312</td> </tr> <tr> <td>...</td> <td>...</td> <td>...</td> </tr> <tr> <td>11111111</td> <td>2.49</td> <td>–86</td> </tr> </tbody> </table>	8-Bit Value	V _{LOOP} – COM Voltage (V)	Die Temperature (°C)	00000000	0	+312	11111111	2.49	–86
8-Bit Value	V _{LOOP} – COM Voltage (V)	Die Temperature (°C)												
00000000	0	+312												
...												
11111111	2.49	–86												

On-Chip ADC Transfer Function Equations

The transfer function equation for the measurement of the voltage between the V_{LOOP} and COM pins is as follows:

$$V_{\text{LOOP}} - \text{COM} = (2.5/256) \times D$$

where D is the 8-bit digital code returned by the on-chip ADC.

The transfer function equation for the die temperature is as follows:

$$\text{Die Temperature} = (-1.559 \times D) + 312$$

where D is the 8-bit digital code returned by the on-chip ADC.

OFFSET ADJUST REGISTER

The offset adjust register is a read/write register and is addressed as described in Table 12.

Table 21. Offset Adjust Register Bit Map

MSB															LSB
D15	D14	D13	D12	D11	D10	D9	D8	D7	D6	D5	D4	D3	D2	D1	D0
16-bit offset adjust data															

Table 22. Offset Adjust Register Adjustment Range

Offset Adjust Register Data	Digital Offset Adjustment (LSBs)
65535	+32767
65534	+32766
...	...
32769	+1
32768 (default)	0
32767	-1
...	...
1	-32767
0	-32768

GAIN ADJUST REGISTER

The gain adjust register is a read/write register and is addressed as described in Table 12.

Table 23. Gain Adjust Register Bit Map

MSB															LSB
D15	D14	D13	D12	D11	D10	D9	D8	D7	D6	D5	D4	D3	D2	D1	D0
16-bit gain adjust data															

Table 24. Gain Adjust Register Adjustment Range

Gain Adjust Register Data	Digital Gain Adjustment at Full-Scale Output (LSBs)
65535 (default)	0
65534	-1
...	...
32769	-32767
32768	-32768
32767	-32769
...	...
1	-65534
0	-65535

Transfer Function Equations with Offset and Gain Adjust Values

When the offset adjust and gain adjust register values are taken into account, the transfer equations can be expressed as follows.

For the 4 mA to 20 mA output range, the loop current can be expressed as follows:

$$I_{LOOP} = \left[\frac{\left(\frac{16 \text{ mA}}{2^{16}} \right) \times Gain}{2^{16}} \times D \right] + \left(4 \text{ mA} + \left[\left(\frac{16 \text{ mA}}{2^{16}} \right) \times (Offset - 32,768) \right] \right)$$

For the 3.8 mA to 21 mA output range, the loop current can be expressed as follows:

$$I_{LOOP} = \left[\frac{\left(\frac{17.2 \text{ mA}}{2^{16}} \right) \times Gain}{2^{16}} \times D \right] + \left(3.8 \text{ mA} + \left[\left(\frac{17.2 \text{ mA}}{2^{16}} \right) \times (Offset - 32,768) \right] \right)$$

For the 3.2 mA to 24 mA output range, the loop current can be expressed as follows:

$$I_{LOOP} = \left[\frac{\left(\frac{20.8 \text{ mA}}{2^{16}} \right) \times Gain}{2^{16}} \times D \right] + \left(3.2 \text{ mA} + \left[\left(\frac{20.8 \text{ mA}}{2^{16}} \right) \times (Offset - 32,768) \right] \right)$$

where:

D is the decimal value of the DAC register.

$Gain$ is the decimal value of the gain adjust register.

$Offset$ is the decimal value of the offset adjust register.

Note that the offset adjust register cannot adjust the zero-scale output value downward.

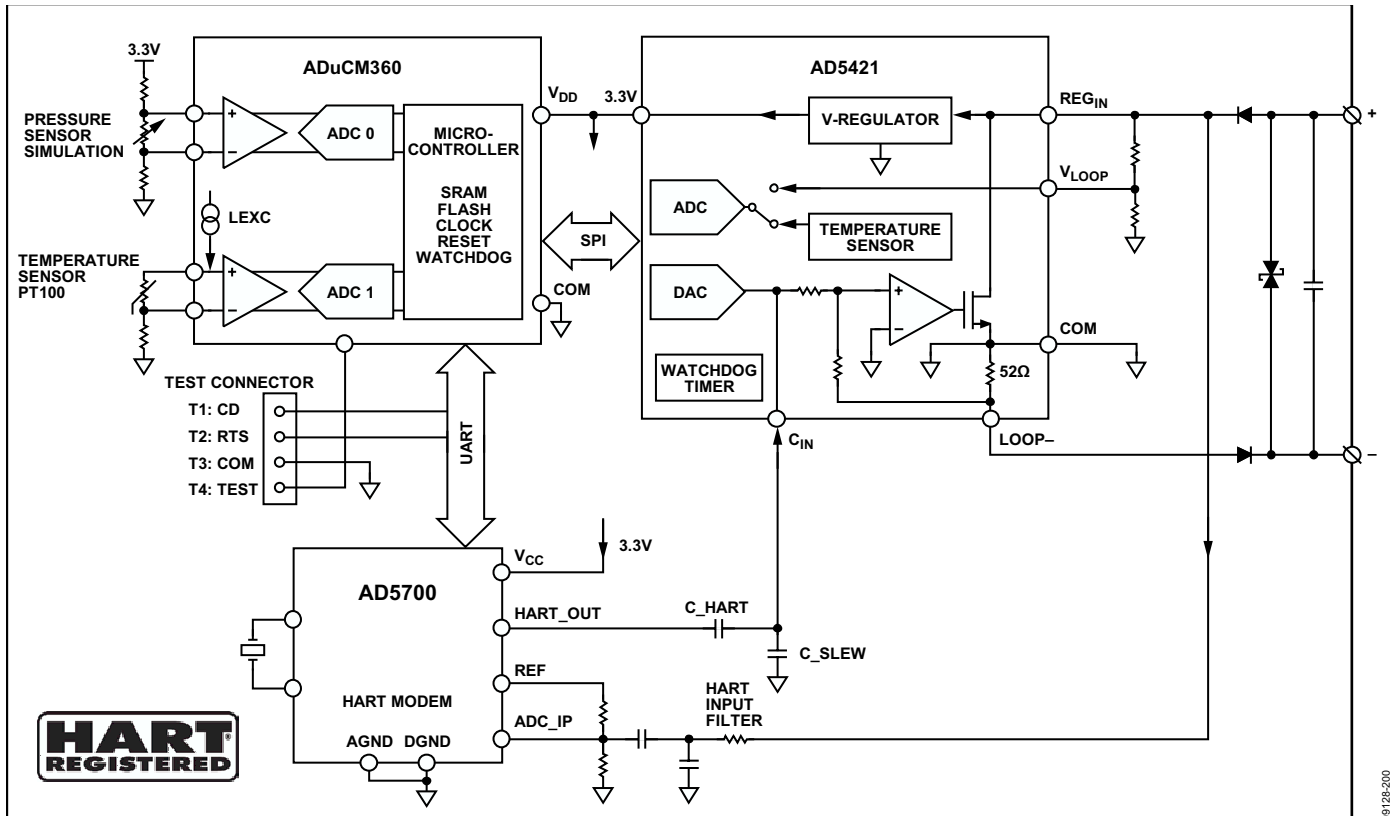

Figure 51. Block Diagram—Analog Devices HART-Enabled Smart Transmitter Reference Demo Circuit

09128-200

To determine the absolute worst-case overall error, the reference and R_{SET} errors can be directly summed with the specified AD5421 maximum error. For example, when using an external reference and external R_{SET} resistor, the maximum AD5421 error is 0.048% of full-scale range. Assuming that the absolute errors for the voltage reference and R_{SET} resistor are, respectively, 0.04% and 0.05% with temperature coefficients of 3 ppm/°C and 2 ppm/°C, respectively, the overall worst-case error is as follows:

$$\text{Worst-Case Error} = \text{AD5421 Error} + V_{REF} \text{ Absolute Error} + V_{REF} \text{ TC} + R_{SET} \text{ Absolute Error} + R_{SET} \text{ TC}$$

$$\text{Worst-Case Error} = 0.048\% + 0.04\% + [(3/10^6) \times 100 \times 145]\% + 0.05\% + [(2/10^6) \times 100 \times 145]\% = 0.21\% \text{ FSR}$$

This is the absolute worst-case value when the AD5421 operates over the temperature range of -40°C to +105°C. An error of this value is very unlikely to occur because the temperature coefficients of the individual components do not exhibit the same drift polarity, and, therefore, an element of cancelation occurs. For this reason, the TC values should be added in a root of squares fashion.

A further improvement can be gained by performing a two-point calibration at zero scale and full scale, thus reducing the absolute errors of the voltage reference and R_{SET} resistor to a combined error of 1 LSB or 0.0015% FSR. After performing this calibration, the total maximum error becomes

$$\text{Total Error} = 0.048\% + 0.0015\% + \sqrt{(0.0435\%)^2 + (0.029\%)^2} = 0.102\% \text{ FSR}$$

To reduce this error value further, a voltage reference and R_{SET} resistor with lower TC specifications must be chosen.

THERMAL AND SUPPLY CONSIDERATIONS

The AD5421 is designed to operate at a maximum junction temperature of 125°C. To ensure reliable and specified operation over the lifetime of the product, it is important that the device not be operated under conditions that cause the junction temperature to exceed this value.

Excessive junction temperature can occur if the AD5421 experiences elevated voltages across its terminals while regulating the loop current at a high value. The resulting junction temperature depends on the ambient temperature.

Table 25 provides the bounds of operation at maximum ambient temperature and maximum supply voltage. This information is displayed graphically in Figure 52 and Figure 53. These figures assume that the exposed paddle is connected to a copper plane of approximately 6 cm².

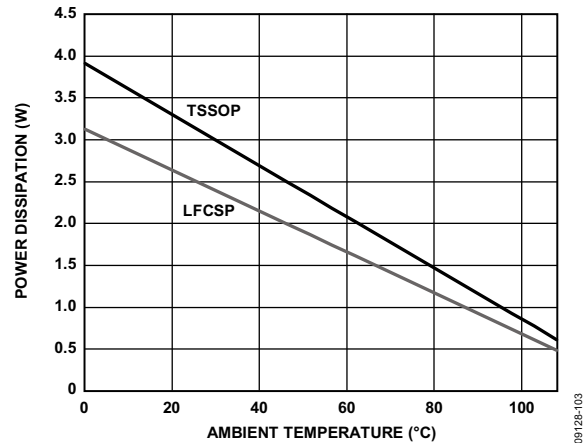

Figure 52. Maximum Power Dissipation vs. Ambient Temperature

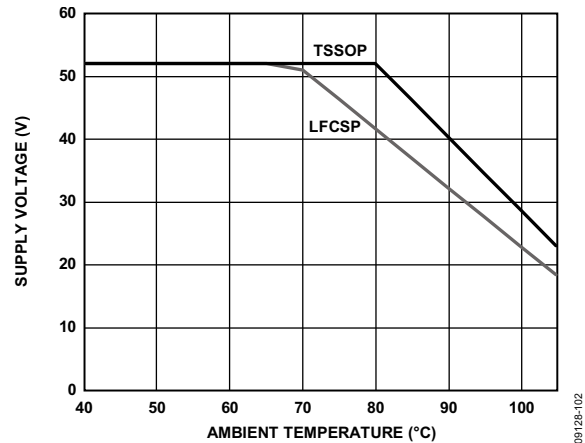
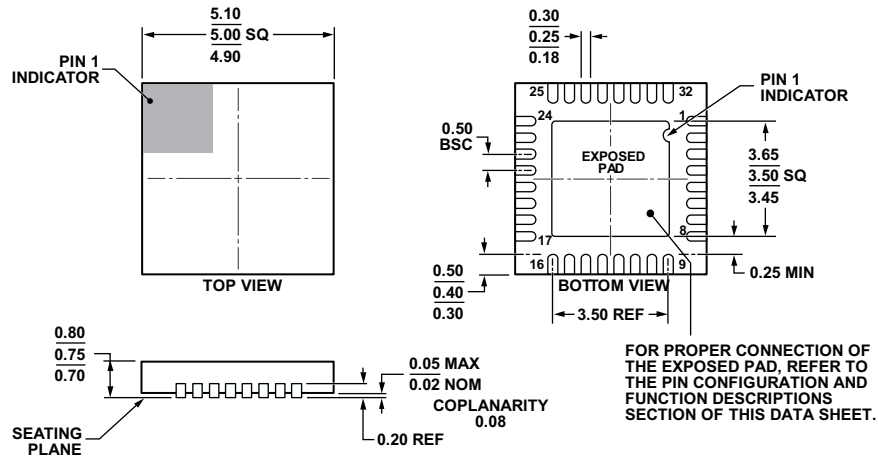

Figure 53. Maximum Supply Voltage vs. Ambient Temperature

Table 25. Thermal and Supply Considerations (External MOSFET Not Connected)

Parameter	Description	32-Lead LFCSP	28-Lead TSSOP
Maximum Power Dissipation	Maximum permitted power dissipation when operating at an ambient temperature of 105°C	$\frac{T_{J\text{MAX}} - T_A}{\theta_{JA}} = \frac{125 - 105}{40} = 500 \text{ mW}$	$\frac{T_{J\text{MAX}} - T_A}{\theta_{JA}} = \frac{125 - 105}{32} = 625 \text{ mW}$
Maximum Ambient Temperature	Maximum permitted ambient temperature when operating from a supply of 52 V while regulating a loop current of 22.8 mA	$T_{J\text{MAX}} - P_D \times \theta_{JA} = 125 - ((52 \times 0.0228) \times 40) = 77^\circ\text{C}$	$T_{J\text{MAX}} - (P_D \times \theta_{JA}) = 125 - ((52 \times 0.0228) \times 32) = 87^\circ\text{C}$
Maximum Supply Voltage	Maximum permitted supply voltage when operating at an ambient temperature of 105°C while regulating a loop current of 22.8 mA	$\frac{T_{J\text{MAX}} - T_A}{I_{\text{LOOP}} \times \theta_{JA}} = \frac{125 - 105}{0.0228 \times 40} = 21 \text{ V}$	$\frac{T_{J\text{MAX}} - T_A}{I_{\text{LOOP}} \times \theta_{JA}} = \frac{125 - 105}{0.0228 \times 32} = 27 \text{ V}$

OUTLINE DIMENSIONS



COMPLIANT TO JEDEC STANDARDS MO-220-WHHD.

Figure 54. 32-Lead Lead Frame Chip Scale Package [LFCSP_WQ]
5 mm x 5 mm Body, Very Very Thin Quad
(CP-32-11)
Dimensions shown in millimeters

04-02-2012-A

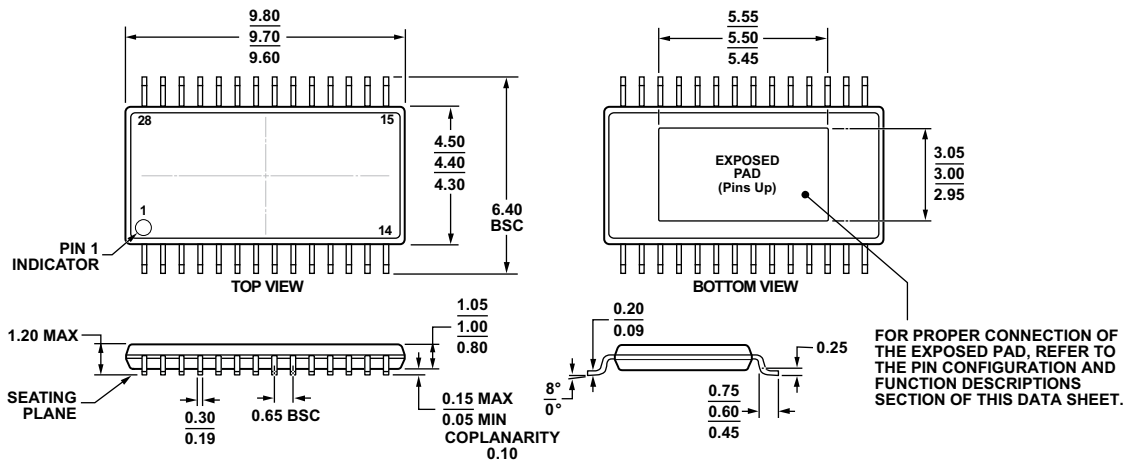

COMPLIANT TO JEDEC STANDARDS MO-153-AET

Figure 55. 28-Lead Thin Shrink Small Outline Package, Exposed Pad [TSSOP_EP]
(RE-28-2)
Dimensions shown in millimeters

05-08-2006-A

ORDERING GUIDE

Model ¹	Temperature Range	Package Description	Package Option
AD5421ACPZ-REEL7	-40°C to +105°C	32-Lead LFCSP_WQ	CP-32-11
AD5421BCPZ-REEL7	-40°C to +105°C	32-Lead LFCSP_WQ	CP-32-11
AD5421BREZ	-40°C to +105°C	28-Lead TSSOP_EP	RE-28-2
AD5421BREZ-REEL	-40°C to +105°C	28-Lead TSSOP_EP	RE-28-2
AD5421BREZ-REEL7	-40°C to +105°C	28-Lead TSSOP_EP	RE-28-2
AD5421CREZ	-40°C to +105°C	28-Lead TSSOP_EP	RE-28-2
AD5421CREZ-RL	-40°C to +105°C	28-Lead TSSOP_EP	RE-28-2
AD5421CREZ-RL7	-40°C to +105°C	28-Lead TSSOP_EP	RE-28-2
EVAL-AD5421SDZ		Evaluation Board	

¹ Z = RoHS Compliant Part.