



## TABLE OF CONTENTS

AD7794—Specifications .....	3	FULL-SCALE Register (RS2, RS1, RS0 = 1, 1, 1; Power-on/Reset = 0x5xxxx5) .....	21
Timing Characteristics .....	9	ADC Circuit Information.....	22
Absolute Maximum Ratings.....	11	Overview .....	22
ESD Caution.....	11	Noise Performance .....	22
Pin Configuration and Function Descriptions.....	12	Digital Interface .....	23
Typical Performance Characteristics .....	14	Single Conversion Mode .....	24
On-chip Registers .....	15	Continuous Conversion Mode .....	24
Communications Register (RS2, RS1, RS0 = 0, 0, 0) .....	15	Continuous Read Mode .....	25
Status Register (RS2, RS1, RS0 = 0, 0, 0; Power-on/Reset = 0x88).....	16	Circuit Description.....	26
Mode Register (RS2, RS1, RS0 = 0, 0, 1; Power-on/Reset = 0x000A).....	16	Analog Input Channel .....	26
Configuration Register (rs2, RS1, RS0 = 0, 1, 0; Power-on/Reset = 0x0710) .....	18	Bipolar/Unipolar Configuration .....	26
Data Register (RS2, RS1, RS0 = 0, 1, 1; Power-on/Reset = 0x000000) .....	20	Data Output Coding .....	26
ID Register (RS2, RS1, RS0 = 1, 0, 0; Power-on/Reset = 0xFF) .....	20	Reference .....	26
IO Register (RS2, RS1, RS0 = 1, 0, 1; Power-on/Reset = 0x00) .....	20	V <sub>DD</sub> Monitor .....	27
OFFSET Register (RS2, RS1, RS0 = 1, 1, 0; Power-on/Reset = 0x800000) .....	21	Grounding and Layout .....	27
		Outline Dimensions .....	29
		Ordering Guide .....	29

## REVISION HISTORY

REV.PrE, June 2004: Initial Version

AD7794—SPECIFICATIONS<sup>1</sup>Table 1. ( $V_{DD} = 2.7\text{ V to }5.25\text{ V}$ ;  $DV_{DD} = 2.7\text{ V to }5.25\text{ V}$ ;  $GND = 0\text{ V}$ ; all specifications  $T_{MIN}$  to  $T_{MAX}$ , unless otherwise noted.)

Parameter	AD7794B	Unit	Test Conditions/Comments
<b>AD7794 (CHOP ENABLED)</b>			
Output Update Rate	4 500	Hz min nom Hz max nom	Settling Time = 2/Output Update Rate
No Missing Codes <sup>2</sup>	24	Bits min	$f_{ADC} \leq 125\text{ Hz}$
Resolution (pk – pk)	16 19	Bits p-p Bits p-p	Gain = 128, 16.6 Hz Update Rate, $V_{REF} = 2.5\text{ V}$ Gain = 1, 16.6 Hz Update Rate, $V_{REF} = 2.5\text{ V}$
Output Noise and Update Rates	See Tables in ADC Description		
Integral Nonlinearity	$\pm 15$ $\pm 25$	ppm of FSR max ppm of FSR max	3.5 ppm typ. Gain = 1 to 32 5 ppm typ, Gain = 64 or 128
Offset Error <sup>3</sup>	$\pm 3$	$\mu\text{V typ}$	
Offset Error Drift vs. Temperature <sup>4</sup>	$\pm 10$	$\text{nV}/^\circ\text{C typ}$	
Full-Scale Error <sup>3,5</sup>	$\pm 10$	$\mu\text{V typ}$	
Gain Drift vs. Temperature <sup>4</sup>	$\pm 0.5$ $\pm 3$	$\text{ppm}/^\circ\text{C typ}$ $\text{ppm}/^\circ\text{C typ}$	Gain = 1 or 2 Gain = 4 to 128
Power Supply Rejection	90	$\text{dB min}$	100 dB typ, $A_{IN} = FS/2$
<b>ANALOG INPUTS</b>			
Differential Input Voltage Ranges	$\pm \text{REFIN}/\text{Gain}$	V nom	REFIN = REFIN(+) – REFIN(–) or Internal Reference, Gain = 1 to 128
Absolute AIN Voltage Limits <sup>2</sup>			
Unbuffered Mode	GND – 30 mV $A_{VDD} + 30\text{ mV}$	V min V max	Gain = 1 or 2
Buffered Mode	GND + 100 mV $A_{VDD} - 100\text{ mV}$	V min V max	Gain = 1 or 2
In-Amp Enabled	GND + 300 mV $A_{VDD} - 1.1$	V min V max	Gain = 4 to 128
Common Mode Voltage	0.5	V min	Gain = 4 to 128
Analog Input Current			
Buffered Mode or In-Amp Enabled			
Average Input Current <sup>2</sup>	$\pm 200$	$\text{pA max}$	
Average Input Current Drift	$\pm 2$	$\text{pA}/^\circ\text{C typ}$	
Unbuffered Mode			
Average Input Current	$\pm 400$	$\text{nA}/\text{V typ}$	Gain = 1 or 2 Input current varies with input voltage.
Average Input Current Drift	$\pm 50$ 1	$\text{pA}/\text{V}/^\circ\text{C typ}$ $\text{nA max}$	$A_{IN6}(+) / A_{IN6}(-)$
Normal Mode Rejection <sup>2</sup>			
Internal Clock			
@ 50 Hz, 60 Hz	70	$\text{dB min}$	80 dB typ, $50 \pm 1\text{ Hz}$ , $60 \pm 1\text{ Hz}$ , $FS[3:0] = 1010^6$
@ 50 Hz	84	$\text{dB min}$	90 dB typ, $50 \pm 1\text{ Hz}$ , $FS[3:0] = 1001^6$
@ 60 Hz	90	$\text{dB min}$	100 dB typ, $60 \pm 1\text{ Hz}$ , $FS[3:0] = 1000^6$
External Clock			
@ 50 Hz, 60 Hz	80	$\text{dB min}$	90 dB typ, $50 \pm 1\text{ Hz}$ , $60 \pm 1\text{ Hz}$ , $FS[3:0] = 1010^6$
@ 50 Hz	94	$\text{dB min}$	100 dB typ, $50 \pm 1\text{ Hz}$ , $FS[3:0] = 1001^6$
@ 60 Hz	90	$\text{dB min}$	100 dB typ, $60 \pm 1\text{ Hz}$ , $FS[3:0] = 1000^6$
Common Mode Rejection			$A_{IN} = +FS/2$
@DC	90	$\text{dB min}$	$FS[3:0] = 1010^6$
@ 50 Hz, 60 Hz <sup>2</sup>	100	$\text{dB min}$	$50 \pm 1\text{ Hz}$ , $60 \pm 1\text{ Hz}$ , $FS[3:0] = 1010^6$
@ 50 Hz, 60 Hz <sup>2</sup>	100	$\text{dB min}$	$50 \pm 1\text{ Hz}$ ( $FS[3:0] = 1001^6$ ), $60 \pm 1\text{ Hz}$ ( $FS[3:0] = 1000^6$ )

Parameter	AD7794B	Unit	Test Conditions/Comments
REFERENCE INPUT			
Internal Reference Initial Accuracy	1.17 ±0.01%	V min/max	Gain = 1, Update Rate = 16.6 Hz. Includes ADC Noise. REFIN = REFIN(+) – REFIN(-)
Internal Reference Drift	5	ppm/°C typ	
	15	ppm/°C max	
Internal Reference Noise	2	μV RMS	
External REFIN Voltage	2.5	V nom	
Reference Voltage Range <sup>2</sup>	0.1	V min	
	AV <sub>DD</sub>	V max	
Absolute REFIN Voltage Limits <sup>2</sup>	GND – 30 mV	V min	
	AV <sub>DD</sub> + 30 mV	V max	
Average Reference Input Current	400	nA/V typ	
Average Reference Input Current Drift	±0.03	nA/V/°C typ	
Normal Mode Rejection <sup>2</sup>	Same as for Analog Inputs		
Common Mode Rejection	Same as for Analog Inputs		
Reference Detect Levels	0.3	V min	NOXREF Bit Inactive if VREF < 0.3 V
	0.65	V max	NOXREF Bit Active if VREF > 0.65 V

Parameter	AD7794B	Unit	Test Conditions/Comments
<b>AD7794 (CHOP DISABLED)</b>			
Output Update Rate	4	Hz min nom	Settling Time = 1/Output Update Rate
	500	Hz max nom	
No Missing Codes <sup>2</sup>	24	Bits min	$f_{ADC} \leq 125$ Hz
Resolution	15.5	Bits p-p	Gain = 128, 16.6 Hz Update Rate, $V_{REF} = 2.5$ V
	18.5	Bits p-p	Gain = 1, 16.6 Hz Update Rate, $V_{REF} = 2.5$ V
Output Noise and Update Rates	See Tables in ADC Description		
Integral Nonlinearity	$\pm 15$	ppm of FSR max	3.5 ppm of FSR typ. Gain = 1 to 32
	$\pm 25$	ppm of FSR max	5 ppm of FSR typ, Gain = 64 or 128
Offset Error <sup>3</sup>	$\pm 200$ /Gain	$\mu$ V typ	Without Calibration
Offset Error Drift vs. Temperature <sup>4</sup>	$\pm 200$ /Gain	nV/ $^{\circ}$ C typ	
Full-Scale Error <sup>3,5</sup>	$\pm 10$	$\mu$ V typ	
Gain Drift vs. Temperature <sup>4</sup>	$\pm 0.5$	ppm/ $^{\circ}$ C typ	Gain = 1 or 2
	$\pm 3$	ppm/ $^{\circ}$ C typ	Gain = 4 to 128
Power Supply Rejection	80	dB min	100 dB typ, $A_{IN} = FS/2$
<b>ANALOG INPUTS</b>			
Differential Input Voltage Ranges	$\pm REF_{IN}/Gain$	V nom	$REF_{IN} = REF_{IN}(+) - REF_{IN}(-)$ or Internal Reference, Gain = 1 to 128
Absolute $A_{IN}$ Voltage Limits <sup>2</sup>			
Unbuffered Mode	GND – 30 mV	V min	Gain = 1 or 2
	$AV_{DD} + 30$ mV	V max	
Buffered Mode	GND + 100 mV	V min	Gain = 1 or 2
	$AV_{DD} - 100$ mV	V max	
In-Amp Enabled	GND + 100 mV	V min	Gain = 4 to 128
	$AV_{DD} - 1.1$	V max	
Common Mode Voltage	0.5	V min	Gain = 4 to 128
Analog Input Current			
Buffered Mode or In-Amp Enabled			
Average Input Current <sup>2</sup>	$\pm 200$	pA max	
Average Input Current Drift	$\pm 2$	pA/ $^{\circ}$ C typ	
Unbuffered Mode			Gain = 1 or 2
Average Input Current	$\pm 400$	nA/V typ	Input current varies with input voltage.
Average Input Current Drift	$\pm 50$	pA/V/ $^{\circ}$ C typ	
	1	nA max	$A_{IN6}(+) / A_{IN6}(-)$
Normal Mode Rejection <sup>2</sup>			
Internal Clock			
@ 50 Hz, 60 Hz	60	dB min	70 dB typ, $50 \pm 1$ Hz, $60 \pm 1$ Hz, $FS[3:0] = 1010^6$
@ 50 Hz	80	dB min	90 dB typ, $50 \pm 1$ Hz, $FS[3:0] = 1001^6$
@ 60 Hz	90	dB min	100 dB typ, $60 \pm 1$ Hz, $FS[3:0] = 1000^6$
External Clock			
@ 50 Hz, 60 Hz	60	dB min	70 dB typ, $50 \pm 1$ Hz, $60 \pm 1$ Hz, $FS[3:0] = 1010^6$
@ 50 Hz	94	dB min	100 dB typ, $50 \pm 1$ Hz, $FS[3:0] = 1001^6$
@ 60 Hz	90	dB min	100 dB typ, $60 \pm 1$ Hz, $FS[3:0] = 1000^6$
Common Mode Rejection			$A_{IN} = +FS/2$
@DC	80	dB min	$FS[3:0] = 1010^6$
@ 50 Hz, 60 Hz <sup>2</sup>	80	dB min	$50 \pm 1$ Hz, $60 \pm 1$ Hz, $FS[3:0] = 1010^6$
@ 50 Hz, 60 Hz <sup>2</sup>	80	dB min	$50 \pm 1$ Hz ( $FS[3:0] = 1001^6$ ), $60 \pm 1$ Hz ( $FS[3:0] = 1000^6$ )
<b>REFERENCE INPUT</b>			
Internal Reference Initial Accuracy	$1.17 \pm 0.01\%$	V min/max	
Internal Reference Drift	5	ppm/ $^{\circ}$ C typ	
	15	ppm/ $^{\circ}$ C max	

Parameter	AD7794B	Unit	Test Conditions/Comments
Internal Reference Noise	2	$\mu\text{V RMS}$	Gain = 1, Update Rate = 16.6 Hz. Includes ADC Noise.
External REFIN Voltage	2.5	V nom	REFIN = REFIN(+) – REFIN(-)
Reference Voltage Range <sup>2</sup>	0.1	V min	
	$V_{DD}$	V max	
Absolute REFIN Voltage Limits <sup>2</sup>	GND – 30 mV	V min	
	$AV_{DD} + 30 \text{ mV}$	V max	
Average Reference Input Current	400	nA/V typ	
Average Reference Input Current Drift	$\pm 0.03$	nA/V/°C typ	
Normal Mode Rejection <sup>2</sup>	Same as for Analog Inputs		
Common Mode Rejection	Same as for Analog Inputs		
Reference Detect Levels	0.3	V min	NOXREF Bit Inactive if VREF < 0.3 V
	0.65	V max	NOXREF Bit Active if VREF > 0.65 V

Parameter	AD7794B	Unit	Test Conditions/Comments
<b>EXCITATION CURRENT SOURCES (IEXC1 and IEXC2)</b>			
Output Current	10/200/1000	μA nom	
Initial Tolerance at 25°C	±5	% typ	
Drift	200	ppm/°C typ	
Initial Current Matching at 25°C	±1	% typ	Matching between IEXC1 and EXC2. $V_{OUT} = 0\text{ V}$
Drift Matching	20	ppm/°C typ	
Line Regulation ( $V_{DD}$ )	2.1	ppm/V max	$AV_{DD} = 5\text{ V} \pm 5\%$ . Typically 1.25 ppm/V
Load Regulation	0.3	ppm/V typ	
Output Compliance	$AV_{DD} - 0.6$ $AV_{DD} - 1$ GND – 30 mV	V max V max V min	Current Sources Programmed to 10 μA or 200 μA Current Sources Programmed to 1 mA
<b>BIAS VOLTAGE GENERATOR</b>			
$V_{BIAS}$	$AV_{DD}/2$	V nom	
$V_{BIAS}$ Generator Start-Up Time	TBD	ms/nF typ	Dependent on the Capacitance connected to AIN
<b>TEMPERATURE SENSOR</b>			
Accuracy	TBD	°C typ	
<b>LOW SIDE POWER SWITCH</b>			
$R_{ON}$	5 7	Ω max Ω max	$AV_{DD} = 5\text{ V}$ $AV_{DD} = 3\text{ V}$
Allowable Current	20	mA max	Continuous Current
<b>DIGITAL OUTPUTS (P1 &amp; P2)</b>			
$V_{OH}$ , Output High Voltage <sup>2</sup>	$AV_{DD} - 0.6$	V min	$AV_{DD} = 3\text{ V}$ , $I_{SOURCE} = 100\text{ μA}$
$V_{OL}$ , Output Low Voltage <sup>2</sup>	0.4	V max	$AV_{DD} = 3\text{ V}$ , $I_{SINK} = 100\text{ μA}$
$V_{OH}$ , Output High Voltage <sup>2</sup>	4	V min	$AV_{DD} = 5\text{ V}$ , $I_{SOURCE} = 200\text{ μA}$
$V_{OL}$ , Output Low Voltage <sup>2</sup>	0.4	V max	$AV_{DD} = 5\text{ V}$ , $I_{SINK} = 800\text{ μA}$
Floating-State Leakage Current	±1	μA max	
Floating-State Output Capacitance	10	pF typ	
<b>INTERNAL/EXTERNAL CLOCK</b>			
Internal Clock			
Frequency	64 ±2%	64 ±2%	
Duty Cycle	50:50	50:50	
Drift	0.01	0.01	
External Clock			
Frequency	64	64	
Duty Cycle	45:55	45:55	
<b>LOGIC INPUTS</b>			
All Inputs Except SCLK, DIN and CLK <sup>2</sup>			
$V_{INL}$ , Input Low Voltage	0.8 0.4	V max V max	$DV_{DD} = 5\text{ V}$ $DV_{DD} = 3\text{ V}$
$V_{INH}$ , Input High Voltage	2.0	V min	$DV_{DD} = 3\text{ V}$ or 5 V
SCLK and DIN (Schmitt-Triggered Input) <sup>2</sup>			
$V_T(+)$	1.4/2	V min/V max	$DV_{DD} = 5\text{ V}$
$V_T(-)$	0.8/1.4	V min/V max	$DV_{DD} = 5\text{ V}$
$V_T(+)$ – $V_T(-)$	0.3/0.85	V min/V max	$DV_{DD} = 5\text{ V}$
$V_T(+)$	0.9/2	V min/V max	$DV_{DD} = 3\text{ V}$
$V_T(-)$	0.4/1.1	V min/V max	$DV_{DD} = 3\text{ V}$
$V_T(+)$ - $V_T(-)$	0.3/0.85	V min/V max	$DV_{DD} = 3\text{ V}$
CLK <sup>2</sup>			
$V_{INL}$ , Input Low Voltage	0.8	V max	$DV_{DD} = 5\text{ V}$
$V_{INL}$ , Input Low Voltage	0.4	V max	$DV_{DD} = 3\text{ V}$
$V_{INH}$ , Input High Voltage	3.5	V min	$DV_{DD} = 5\text{ V}$

Parameter	AD7794B	Unit	Test Conditions/Comments
$V_{INH}$ , Input High Voltage	2.5	V min	$DV_{DD} = 3\text{ V}$
Input Currents	$\pm 1$	$\mu\text{A max}$	$V_{IN} = DV_{DD}$ or GND
Input Capacitance	10	pF typ	All Digital Inputs
<b>LOGIC OUTPUTS (Including CLK)</b>			
$V_{OH}$ , Output High Voltage <sup>2</sup>	$DV_{DD} - 0.6$	V min	$DV_{DD} = 3\text{ V}$ , $I_{SOURCE} = 100\ \mu\text{A}$
$V_{OL}$ , Output Low Voltage <sup>2</sup>	0.4	V max	$DV_{DD} = 3\text{ V}$ , $I_{SINK} = 100\ \mu\text{A}$
$V_{OH}$ , Output High Voltage <sup>2</sup>	4	V min	$DV_{DD} = 5\text{ V}$ , $I_{SOURCE} = 200\ \mu\text{A}$
$V_{OL}$ , Output Low Voltage <sup>2</sup>	0.4	V max	$DV_{DD} = 5\text{ V}$ , $I_{SINK} = 1.6\text{ mA}$ ( $\overline{DOUT}/\overline{RDY}$ )/800 $\mu\text{A}$ (CLK)
Floating-State Leakage Current	$\pm 1$	$\mu\text{A max}$	
Floating-State Output Capacitance	10	pF typ	
Data Output Coding	Offset Binary		
<b>SYSTEM CALIBRATION<sup>2</sup></b>			
Full-Scale Calibration Limit	1.05 x FS	V max	
Zero-Scale Calibration Limit	-1.05 x FS	V min	
Input Span	0.8 x FS	V min	
	2.1 x FS	V min	
<b>POWER REQUIREMENTS<sup>7</sup></b>			
Power Supply Voltage			
$AV_{DD} - \text{GND}$	2.7/5.25	V min/max	
$DV_{DD} - \text{GND}$	2.7/5.25	V min/max	
Power Supply Currents			
$I_{DD}$ Current	150	$\mu\text{A max}$	125 $\mu\text{A typ}$ , Unbuffered Mode, Ext. Reference
	175	$\mu\text{A max}$	150 $\mu\text{A typ}$ , Buffered Mode, In-Amp Bypassed, Ext Ref
	380	$\mu\text{A max}$	330 $\mu\text{A typ}$ , In-Amp used, Ext. Ref
	450	$\mu\text{A max}$	400 $\mu\text{A typ}$ , In-Amp used, Int Ref
$I_{DD}$ (Power-Down Mode)	1	$\mu\text{A max}$	

<sup>1</sup> Temperature Range  $-40^{\circ}\text{C}$  to  $+105^{\circ}\text{C}$ .

<sup>2</sup> Specification is not production tested but is supported by characterization data at initial product release.

<sup>3</sup> Following a self-calibration, this error will be in the order of the noise for the programmed gain and update rate selected. A system calibration will completely remove this error.

<sup>4</sup> Recalibration at any temperature will remove these errors.

<sup>5</sup> Full-scale error applies to both positive and negative full-scale and applies at the factory calibration conditions ( $AV_{DD} = 4\text{ V}$ ).

<sup>6</sup> FS[3:0] are the four bits used in the mode register to select the output word rate.

<sup>7</sup> Digital inputs equal to  $DV_{DD}$  or GND.

TIMING CHARACTERISTICS<sup>8, 9</sup>Table 2. ( $V_{DD} = 2.7\text{ V to }5.25\text{ V}$ ;  $DV_{DD} = 2.7\text{ V to }5.25$ ;  $GND = 0\text{ V}$ , Input Logic 0 = 0 V, Input Logic 1 =  $DV_{DD}$ , unless otherwise noted.)

Parameter	Limit at $T_{MIN}, T_{MAX}$ (B Version)	Unit	Conditions/Comments
$t_3$	100	ns min	SCLK High Pulsewidth
$t_4$	100	ns min	SCLK Low Pulsewidth
Read Operation			
$t_1$	0	ns min	$\overline{CS}$ Falling Edge to $\overline{DOUT}/\overline{RDY}$ Active Time
	60	ns max	$DV_{DD} = 4.75\text{ V to }5.25\text{ V}$
	80	ns max	$DV_{DD} = 2.7\text{ V to }3.6\text{ V}$
$t_2^{10}$	0	ns min	SCLK Active Edge to Data Valid Delay <sup>11</sup>
	60	ns max	$DV_{DD} = 4.75\text{ V to }5.25\text{ V}$
	80	ns max	$DV_{DD} = 2.7\text{ V to }3.6\text{ V}$
$t_5^{12, 13}$	10	ns min	Bus Relinquish Time after $\overline{CS}$ Inactive Edge
	80	ns max	
$t_6$	100	ns max	SCLK Inactive Edge to $\overline{CS}$ Inactive Edge
$t_7$	10	ns min	SCLK Inactive Edge to $\overline{DOUT}/\overline{RDY}$ High
Write Operation			
$t_8$	0	ns min	$\overline{CS}$ Falling Edge to SCLK Active Edge Setup Time <sup>11</sup>
$t_9$	30	ns min	Data Valid to SCLK Edge Setup Time
$t_{10}$	25	ns min	Data Valid to SCLK Edge Hold Time
$t_{11}$	0	ns min	$\overline{CS}$ Rising Edge to SCLK Edge Hold Time

<sup>8</sup> Sample tested during initial release to ensure compliance. All input signals are specified with  $t_r = t_f = 5\text{ ns}$  (10% to 90% of  $DV_{DD}$ ) and timed from a voltage level of 1.6 V.

<sup>9</sup> See Figure 2 and Figure 3.

<sup>10</sup> These numbers are measured with the load circuit of

Figure 1 and defined as the time required for the output to cross the  $V_{OL}$  or  $V_{OH}$  limits.

<sup>11</sup> SCLK active edge is falling edge of SCLK.

<sup>12</sup> These numbers are derived from the measured time taken by the data output to change 0.5 V when loaded with the circuit of

Figure 1. The measured number is then extrapolated back to remove the effects of charging or discharging the 50 pF capacitor. This means that the times quoted in the timing characteristics are the true bus relinquish times of the part and, as such, are independent of external bus loading capacitances.

<sup>13</sup>  $\overline{RDY}$  returns high after a read of the ADC. In single conversion mode and continuous conversion mode, the same data can be read again, if required, while  $\overline{RDY}$  is high, although care should be taken to ensure that subsequent reads do not occur close to the next output update. In continuous read mode, the digital word can be read only once.

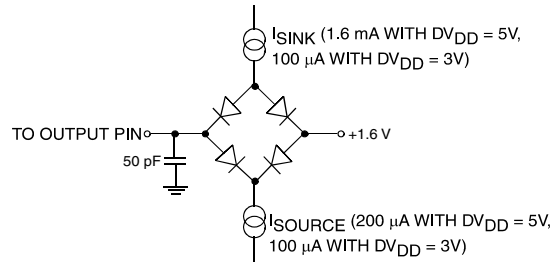

Figure 1. Load Circuit for Timing Characterization

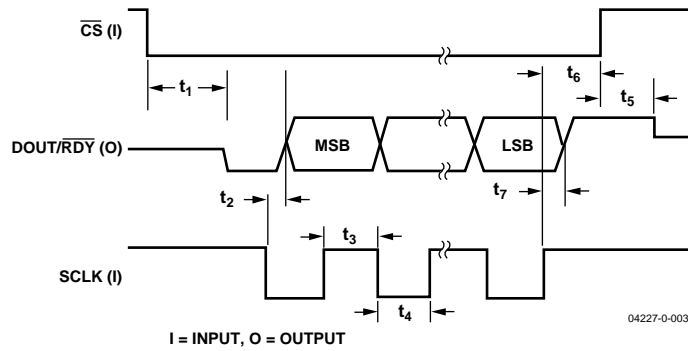

Figure 2. Read Cycle Timing Diagram

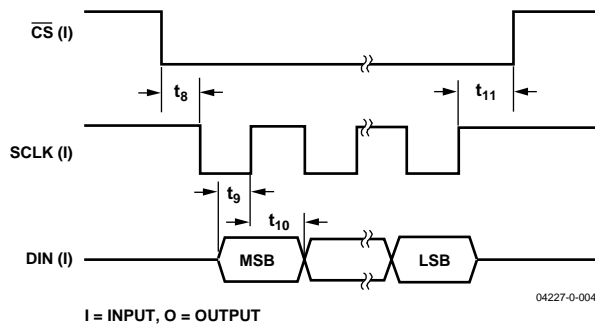

Figure 3. Write Cycle Timing Diagram

## ABSOLUTE MAXIMUM RATINGS

Table 3. ( $T_A = 25^\circ\text{C}$ , unless otherwise noted.)

Parameter	Rating
$AV_{DD}$ to GND	-0.3 V to +7 V
$DV_{DD}$ to GND	-0.3 V to +7 V
Analog Input Voltage to GND	-0.3 V to $AV_{DD} + 0.3$ V
Reference Input Voltage to GND	-0.3 V to $AV_{DD} + 0.3$ V
Digital Input Voltage to GND	-0.3 V to $AV_{DD} + 0.3$ V
Digital Output Voltage to GND	-0.3 V to $AV_{DD} + 0.3$ V
AIN/Digital Input Current	10 mA
Operating Temperature Range	$-40^\circ\text{C}$ to $+105^\circ\text{C}$
Storage Temperature Range	$-65^\circ\text{C}$ to $+150^\circ\text{C}$
Maximum Junction Temperature	$150^\circ\text{C}$
TSSOP	
$\theta_{JA}$ Thermal Impedance	$97.9^\circ\text{C}/\text{W}$
$\theta_{JC}$ Thermal Impedance	$14^\circ\text{C}/\text{W}$
Lead Temperature, Soldering	
Vapor Phase (60 sec)	$215^\circ\text{C}$
Infrared (15 sec)	$220^\circ\text{C}$

Stresses above those listed under Absolute Maximum Ratings may cause permanent damage to the device. This is a stress rating only; functional operation of the device at these or any other conditions above those listed in the operational sections of this specification is not implied. Exposure to absolute maximum rating conditions for extended periods may affect device reliability.

### ESD CAUTION

ESD (electrostatic discharge) sensitive device. Electrostatic charges as high as 4000 V readily accumulate on the human body and test equipment and can discharge without detection. Although this product features proprietary ESD protection circuitry, permanent damage may occur on devices subjected to high energy electrostatic discharges. Therefore, proper ESD precautions are recommended to avoid performance degradation or loss of functionality.



## PIN CONFIGURATION AND FUNCTION DESCRIPTIONS

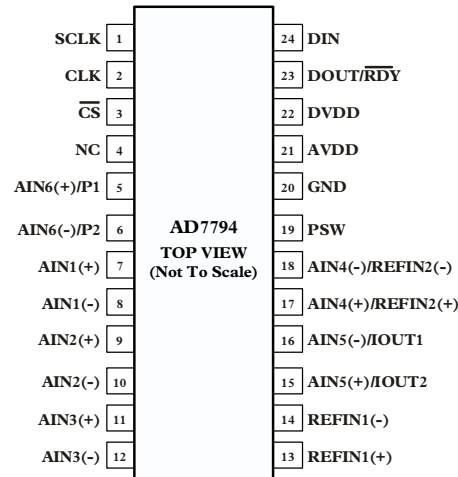

Figure 4. Pin Configuration

Table 4. Pin Function Descriptions

Pin No.	Mnemonic	Function
1	SCLK	Serial Clock Input for Data Transfers to and from the ADC. The SCLK has a Schmitt-triggered input, making the interface suitable for opto-isolated applications. The serial clock can be continuous with all data transmitted in a continuous train of pulses. Alternatively, it can be a noncontinuous clock with the information being transmitted to or from the ADC in smaller batches of data.
2	CLK	Clock In/Clock Out. The internal clock can be made available at this pin. Alternatively, the internal clock can be disabled and the ADC can be driven by an external clock. This allows several ADCs to be driven from a common clock, allowing simultaneous conversions to be performed.
3	$\overline{\text{CS}}$	Chip Select Input. This is an active low logic input used to select the ADC. $\overline{\text{CS}}$ can be used to select the ADC in systems with more than one device on the serial bus or as a frame synchronization signal in communicating with the device. $\overline{\text{CS}}$ can be hardwired low, allowing the ADC to operate in 3-wire mode with SCLK, DIN, and DOUT used to interface with the device.
4	NC	No Connect
5	AIN6(+)/P1	Analog Input/Digital Output pin. AIN6(+) is the positive terminal of the differential analog input pair AIN6(+)/AIN6(-). Alternatively, this pin can function as a general purpose output bit referenced between AV <sub>DD</sub> and GND
6	AIN6(-)/P2	Analog Input/ Digital Output pin. AIN6(-) is the negative terminal of the differential analog input pair AIN6(+)/AIN6(-). Alternatively, this pin can function as a general purpose output bit referenced between AV <sub>DD</sub> and GND
7	AIN1(+)	Analog Input. AIN1(+) is the positive terminal of the differential analog input pair AIN1(+)/AIN1(-).
8	AIN1(-)	Analog Input. AIN1(-) is the negative terminal of the differential analog input pair AIN1(+)/AIN1(-).
9	AIN2(+)	Analog Input. AIN2(+) is the positive terminal of the differential analog input pair AIN2(+)/AIN2(-).
10	AIN2(-)	Analog Input. AIN2(-) is the negative terminal of the differential analog input pair AIN2(+)/AIN2(-).
11	AIN3(+)	Analog Input. AIN3(+) is the positive terminal of the differential analog input pair AIN3(+)/AIN3(-).
12	AIN3(-)	Analog Input. AIN3(-) is the negative terminal of the differential analog input pair AIN3(+)/AIN3(-).
13	REFIN1(+)	Positive Reference Input. An external reference can be applied between REFIN1(+) and REFIN1(-). REFIN1(+) can lie anywhere between V <sub>DD</sub> and GND + 0.1 V. The nominal reference voltage (REFIN1(+) – REFIN1(-)) is 2.5 V, but the part functions with a reference from 0.1 V to AV <sub>DD</sub> .
14	REFIN1(-)	Negative Reference Input. This reference input can lie anywhere between GND and AV <sub>DD</sub> – 0.1 V.
15	AIN5(+)/IOUT2	Analog Input/Output of Internal Excitation Current Source. AIN5(+) is the positive terminal of the differential analog input pair AIN5(+)/AIN5(-). Alternatively, the internal excitation current source can be made available at this pin. The excitation current source is programmable so that the current can be 10 uA, 200 uA or 1 mA. Either IEXC1 or IEXC2 can be switched to this output
16	AIN5(-)/IOUT1	Analog Input/Output of Internal Excitation Current Source.

Pin No.	Mnemonic	Function
17	AIN4(+)/REFIN2(+)	<p>AIN5(-) is the negative terminal of the differential analog input pair AIN5(+)/AIN5(-). Alternatively, the internal excitation current source can be made available at this pin. The excitation current source is programmable so that the current can be 10 uA, 200 uA or 1 mA. Either IEXC1 or IEXC2 can be switched to this output.</p> <p>Analog Input/Positive Reference Input.</p> <p>AIN4(+) is the positive terminal of the differential analog input pair AIN4(+)/AIN4(-). This pin can also function as a reference input. REFIN2(+) can lie anywhere between <math>AV_{DD}</math> and <math>GND + 0.1 V</math>. The nominal reference voltage (REFIN2(+) – REFIN2(-)) is 2.5 V, but the part functions with a reference from 0.1 V to <math>AV_{DD}</math>.</p>
18	AIN4(-)/REFIN2(-)	<p>Analog Input/Negative Reference Input.</p> <p>AIN4(-) is the negative terminal of the differential analog input pair AIN4(+)/AIN4(-). This pin also functions as the negative reference input for REFIN2. This reference input can lie anywhere between <math>GND</math> and <math>AV_{DD} - 0.1 V</math>.</p>
19	PSW	Low Side Power Switch to $GND$ .
20	$GND$	Ground Reference Point.
21	$AV_{DD}$	Supply Voltage, 2.7 V to 5.25 V.
22	$DV_{DD}$	Serial Interface Supply Voltage, 2.7 V to 5.25 V. $DV_{DD}$ is independent of $AV_{DD}$ . Therefore, the serial interface can be operated at 3 V with $AV_{DD}$ at 5 V or vice versa.
23	DOUT/ $\overline{RDY}$	<p>Serial Data Output/Data Ready Output. DOUT/<math>\overline{RDY}</math> serves a dual purpose. It functions as a serial data output pin to access the output shift register of the ADC. The output shift register can contain data from any of the on-chip data or control registers. In addition, DOUT/<math>\overline{RDY}</math> operates as a data ready pin, going low to indicate the completion of a conversion. If the data is not read after the conversion, the pin will go high before the next update occurs.</p> <p>The DOUT/<math>\overline{RDY}</math> falling edge can be used as an interrupt to a processor, indicating that valid data is available. With an external serial clock, the data can be read using the DOUT/<math>\overline{RDY}</math> pin. With <math>\overline{CS}</math> low, the data/control word information is placed on the DOUT/<math>\overline{RDY}</math> pin on the SCLK falling edge and is valid on the SCLK rising edge.</p> <p>The end of a conversion is also indicated by the <math>\overline{RDY}</math> bit in the status register. When <math>\overline{CS}</math> is high, the DOUT/<math>\overline{RDY}</math> pin is three-stated but the <math>\overline{RDY}</math> bit remains active.</p>
24	DIN	Serial Data Input to the Input Shift Register on the ADC. Data in this shift register is transferred to the control registers within the ADC, the register selection bits of the communications register identifying the appropriate register.

### TYPICAL PERFORMANCE CHARACTERISTICS

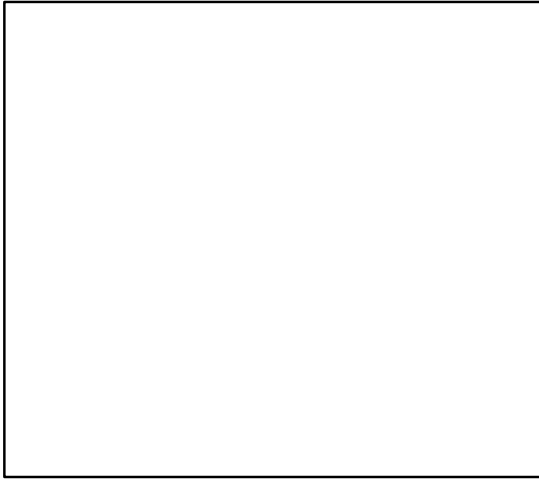

Figure 5.

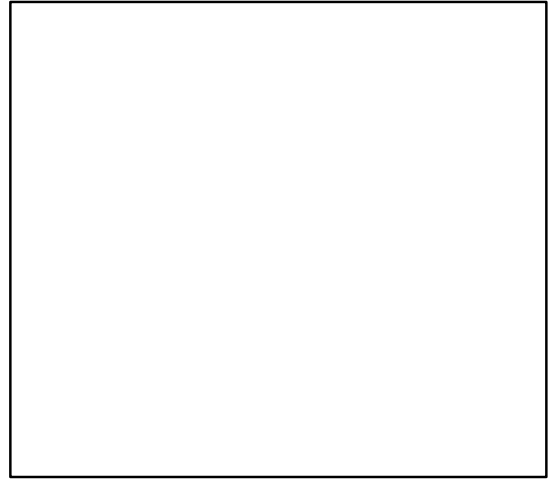

Figure 8.

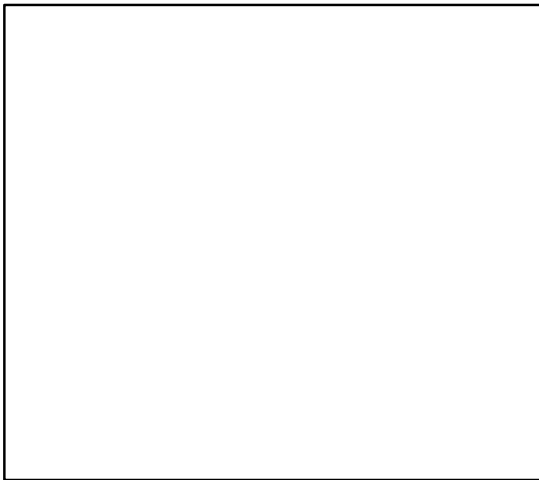

Figure 6.

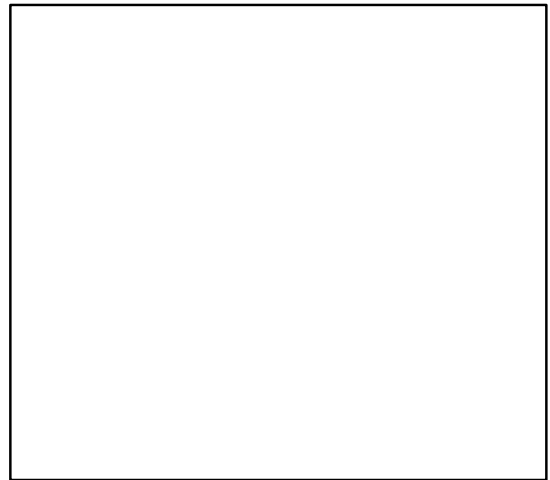

Figure 9.



Figure 7.



Figure 10.

## ON-CHIP REGISTERS

The ADC is controlled and configured via a number of on-chip registers, which are described on the following pages. In the following descriptions, *set* implies a Logic 1 state and *cleared* implies a Logic 0 state, unless otherwise stated.

### COMMUNICATIONS REGISTER (RS2, RS1, RS0 = 0, 0, 0)

The communications register is an 8-bit write-only register. All communications to the part must start with a write operation to the communications register. The data written to the communications register determines whether the next operation is a read or write operation, and to which register this operation takes place. For read or write operations, once the subsequent read or write operation to the selected register is complete, the interface returns to where it expects a write operation to the communications register. This is the default state of the interface and, on power-up or after a reset, the ADC is in this default state waiting for a write operation to the communications register. In situations where the interface sequence is lost, a write operation of at least 32 serial clock cycles with DIN high returns the ADC to this default state by resetting the entire part. Table 5 outlines the bit designations for the communications register. CR0 through CR7 indicate the bit location, CR denoting the bits are in the communications register. CR7 denotes the first bit of the data stream. The number in brackets indicates the power-on/reset default status of that bit.

CR7	CR6	CR5	CR4	CR3	CR2	CR1	CR0
WEN(0)	R/W(0)	RS2(0)	RS1(0)	RS0(0)	CREAD(0)	0(0)	0(0)

**Table 5. Communications Register Bit Designations**

Bit Location	Bit Name	Description
CR7	WEN	Write Enable Bit. A 0 must be written to this bit so that the write to the communications register actually occurs. If a 1 is the first bit written, the part will not clock on to subsequent bits in the register. It will stay at this bit location until a 0 is written to this bit. Once a 0 is written to the WEN bit, the next seven bits will be loaded to the communications register.
CR6	R/W	A 0 in this bit location indicates that the next operation will be a write to a specified register. A 1 in this position indicates that the next operation will be a read from the designated register.
CR5–CR3	RS2–RS0	Register Address Bits. These address bits are used to select which of the ADC's registers are being selected during this serial interface communication. See Table 6.
CR2	CREAD	Continuous Read of the Data Register. When this bit is set to 1 (and the data register is selected), the serial interface is configured so that the data register can be continuously read, i.e., the contents of the data register are placed on the DOUT pin automatically when the SCLK pulses are applied. The communications register does not have to be written to for data reads. To enable continuous read mode, the instruction 01011100 must be written to the communications register. To exit the continuous read mode, the instruction 01011000 must be written to the communications register while the RDY pin is low. While in continuous read mode, the ADC monitors activity on the DIN line so that it can receive the instruction to exit continuous read mode. Additionally, a reset will occur if 32 consecutive 1s are seen on DIN. Therefore, DIN should be held low in continuous read mode until an instruction is to be written to the device.
CR1–CR0	0	These bits must be programmed to logic 0 for correct operation.

**Table 6. Register Selection**

RS2	RS1	RS0	Register	Register Size
0	0	0	Communications Register during a Write Operation	8-Bit
0	0	0	Status Register during a Read Operation	8-Bit
0	0	1	Mode Register	16-Bit
0	1	0	Configuration Register	16-Bit
0	1	1	Data Register	24-Bit
1	0	0	ID Register	8-Bit
1	0	1	IO Register	8-Bit
1	1	0	Offset Register	24-Bit
1	1	1	Full-Scale Register	24-Bit

**STATUS REGISTER (RS2, RS1, RS0 = 0, 0, 0; POWER-ON/RESET = 0x88)**

The status register is an 8-bit read-only register. To access the ADC status register, the user must write to the communications register, select the next operation to be a read, and load bits RS2, RS1 and RS0 with 0. Table 7 outlines the bit designations for the status register. SR0 through SR7 indicate the bit locations, SR denoting the bits are in the status register. SR7 denotes the first bit of the data stream. The number in brackets indicates the power-on/reset default status of that bit.

SR7	SR6	SR5	SR4	SR3	SR2	SR1	SR0
RDY(1)	ERR(0)	NOREF(0)	0(0)	1(1)	CH2(0)	CH1(0)	CH0(0)

**Table 7. Status Register Bit Designations**

Bit Location	Bit Name	Description
SR7	RDY	Ready bit for ADC. <i>Cleared</i> when data is written to the ADC data register. The RDY bit is <i>set</i> automatically after the ADC data register has been read or a period of time before the data register is updated with a new conversion result to indicate to the user not to read the conversion data. It is <i>also set</i> when the part is placed in power-down mode. The end of a conversion is indicated by the DOUT/RDY pin also. This pin can be used as an alternative to the status register for monitoring the ADC for conversion data.
SR6	ERR	ADC Error Bit. This bit is written to at the same time as the RDY bit. <i>Set</i> to indicate that the result written to the ADC data register has been clamped to all 0s or all 1s. Error sources include overrange, underrange or the absence of a reference voltage. <i>Cleared</i> by a write operation to start a conversion.
SR5	NOREF	No External Reference Bit. <i>Set</i> to indicate that the selected reference (REFIN1 or REFIN2) is at a voltage that is below a specified threshold. When <i>set</i> , conversion results are clamped to all ones. <i>Cleared</i> to indicate that a valid reference is applied to the selected reference pins. The NOXREF bit is enabled by setting the REF_DET bit in the Configuration register to 1. The ERR bit is also <i>set</i> if the voltage applied to the selected reference input is invalid.
SR4	0	This bit is automatically <i>cleared</i> .
SR3	1	This bit is automatically <i>set</i> .
SR2–SR0	CH2–CH0	These bits indicate which channel is being converted by the ADC.

**MODE REGISTER (RS2, RS1, RS0 = 0, 0, 1; POWER-ON/RESET = 0x000A)**

The mode register is a 16-bit register from which data can be read or to which data can be written. This register is used to select the operating mode, the update rate and the clock source. Table 8 outlines the bit designations for the mode register. MR0 through MR15 indicate the bit locations, MR denoting the bits are in the mode register. MR15 denotes the first bit of the data stream. The number in brackets indicates the power-on/reset default status of that bit. Any write to the setup register resets the modulator and filter and sets the RDY bit.

MR15	MR14	MR13	MR12	MR11	MR10	MR9	MR8
MD2(0)	MD1(0)	MD0(0)	PSW(0)	0(0)	0(0)	0(0)	0(0)
MR7	MR6	MR5	MR4	MR3	MR2	MR1	MR0
CLK1(0)	CLK0(0)	0(0)	CHOP-DIS (0)	FS3(1)	FS2(0)	FS1(1)	FS0(0)

**Table 8. Mode Register Bit Designations**

Bit Location	Bit Name	Description
MR15–MR13	MD2–MD0	Mode Select Bits. These bits select the operational mode of the AD7794 (See Table 9).
MR12	PSW	Power Switch Control Bit. <i>Set</i> by user to close the power switch PSW to GND. The power switch can sink up to 20 mA. <i>Cleared</i> by user to open the power switch. When the ADC is placed in power-down mode, the power switch is opened.
MR11–MR8	0	These bits must be programmed with a Logic 0 for correct operation.
MR7–MR6	CLK1–CLK0	These bits are used to select the clock source for the AD7794. Either the on-chip 64 kHz clock can be used or an external clock can be used. The ability to use an external clock is useful as it allows several AD7794 devices to be synchronised. Also, 50 Hz/60 Hz rejection is improved when an accurate external clock drives the AD7794.

Bit Location	Bit Name	Description		
		CLK1	CLK0	ADC Clock Source
		0	0	Internal 64 kHz Clock, Internal Clock is not available at the CLK pin
		0	1	Internal 64 kHz Clock. This clock is made available at the CLK pin
		1	0	External 64 kHz Clock used. The external clock can have a 45:55 duty cycle.
		1	1	External Clock used. This external clock is divided by 2 within the AD7794. This allows the user to supply a clock which has a duty cycle worse than a 45:55 duty cycle to the AD7794, for example, a 128 kHz clock.
MR5	0	This bit must be programmed with a Logic 0 for correct operation.		
MR4	CHOP-DIS	This bit is used to enable or disable chopping. On power-up or following a reset, CHOP-DIS is cleared so chopping is enabled. When CHOP-DIS is set, chopping is disabled.		
MR3-MR0	FS3-FS0	Filter Update Rate Select Bits (see Table 10).		

Table 9. Operating Modes

MD2	MD1	MD0	Mode
0	0	0	<p>Continuous Conversion Mode (Default).</p> <p>In continuous conversion mode, the ADC continuously performs conversions and places the result in the data register. RDY goes low when a conversion is complete. The user can read these conversions by placing the device in continuous read mode whereby the conversions are automatically placed on the DOUT line when SCLK pulses are applied. Alternatively, the user can instruct the ADC to output the conversion by writing to the communications register. After power-on, the first conversion is available after a period <math>2/f_{ADC}</math> when chopping is enabled or <math>1/f_{ADC}</math> when chopping is disabled. Subsequent conversions are available at a frequency of <math>f_{ADC}</math> with chopping either enabled or disabled,</p>
0	0	1	<p>Single Conversion Mode.</p> <p>In single conversion mode, the ADC is placed in power-down mode when conversions are not being performed. When single conversion mode is selected, the ADC powers up and performs a single conversion, which occurs after a period <math>2/f_{ADC}</math> when chopping is enabled or <math>1/f_{ADC}</math> when chopping is disabled. The conversion result is placed in the data register, RDY goes low, and the ADC returns to power-down mode. The conversion remains in the data register and RDY remains active (low) until the data is read or another conversion is performed.</p>
0	1	0	<p>Idle Mode.</p> <p>In Idle Mode, the ADC Filter and Modulator are held in a reset state although the modulator clocks are still provided</p>
0	1	1	<p>Power-Down Mode.</p> <p>In power down mode, all the AD7794 circuitry is powered down including the current sources, power switch, burnout currents, bias voltage generator and CLKOUT circuitry.</p>
1	0	0	<p>Internal Zero-Scale Calibration.</p> <p>An internal short is automatically connected to the enabled channel. A calibration takes 2 conversion cycles to complete when chopping is enabled and 1 conversion cycle when chopping is disabled. RDY goes high when the calibration is initiated and returns low when the calibration is complete. The ADC is placed in idle mode following a calibration. The measured offset coefficient is placed in the offset register of the selected channel</p>
1	0	1	<p>Internal Full-Scale Calibration.</p> <p>The fullscale input voltage is automatically connected to the selected analog input for this calibration. The full-scale error of the AD7794 is calibrated at a gain of 1 using the internal reference in the factory. When a channel is operated with a gain of 1 and the internal reference is selected, this factory-calibrated value is loaded into the full-scale register when a full-scale calibration is initiated.</p> <p>When an external reference is selected at a gain of 1, an internal fullscale calibration can be performed. When the gain equals 1, a calibration takes 2 conversion cycles to complete when chopping is enabled and 1 conversion cycle when chopping is disabled.</p> <p>For higher gains, 4 conversion cycles are required to perform the fullscale calibration when chopping is enabled and 2 conversion cycles when chopping is disabled.</p> <p>RDY goes high when the calibration is initiated and returns low when the calibration is complete. The ADC is placed in idle mode following a calibration. The measured fullscale coefficient is placed in the fullscale register of the selected channel.</p> <p>Internal full-scale calibrations cannot be performed when the gain equals 128. With this gain setting, a system full-scale calibration can be performed.</p>

1	1	0	<p>A fullscale calibration is required each time the gain of a channel is changed.</p> <p>System Offset Calibration.</p> <p>User should connect the system zero-scale input to the .channel input pins as selected by the CH2-CH0 bits. A system offset calibration takes 2 conversion cycles to complete when chopping is enabled and one conversion cycle when chopping is disabled. RDY goes high when the calibration is initiated and returns low when the calibration is complete. The ADC is placed in idle mode following a calibration. The measured offset coefficient is placed in the offset register of the selected channel.</p>
1	1	1	<p>System Full-Scale Calibration.</p> <p>User should connect the system full-scale input to the .channel input pins as selected by the CH2-CH0 bits. A calibration takes 2 conversion cycles to complete when chopping is enabled and one conversion cycle when chopping is disabled.. RDY goes high when the calibration is initiated and returns low when the calibration is complete. The ADC is placed in idle mode following a calibration. The measured fullscale coefficient is placed in the fullscale register of the selected channel.</p> <p>A fullscale calibration is required each time the gain of a channel is changed.</p>

Table 10. Update Rates Available (Chopping Enabled)

FS3	FS2	FS1	FS0	f <sub>ADC</sub> (Hz)	T <sub>settle</sub> (ms)	Rejection@ 50 Hz / 60 Hz (Internal Clock)
0	0	0	0	x	x	
0	0	0	1	500	5	
0	0	1	0	250	8	
0	0	1	1	125	16	
0	1	0	0	62.5	32	
0	1	0	1	50	40	
0	1	1	0	41.6	48	
0	1	1	1	33.3	60	
1	0	0	0	19.6	101	90 dB (60 Hz only)
1	0	0	1	16.6	120	84 dB (50 Hz only)
<b>1</b>	<b>0</b>	<b>1</b>	<b>0</b>	<b>16.6</b>	<b>120</b>	<b>70 dB (50 Hz and 60 Hz)</b>
1	0	1	1	12.5	160	67 dB (50 Hz and 60 Hz)
1	1	0	0	10	200	69 dB (50 Hz and 60 Hz)
1	1	0	1	8.33	240	73 dB (50 Hz and 60 Hz)
1	1	1	0	6.25	320	74 dB (50 Hz and 60 Hz)
1	1	1	1	4.17	480	79 dB (50 Hz and 60 Hz)

With chopping disabled, the update rates remain unchanged but the settling time for each update rate is reduced by a factor of 2. The rejection at 50 Hz/60 Hz for a 16.6 Hz update rate degrades to 60 dB.

### CONFIGURATION REGISTER (RS2, RS1, RS0 = 0, 1, 0; POWER-ON/RESET = 0x0710)

The configuration register is a 16-bit register from which data can be read or to which data can be written. This register is used to configure the ADC for unipolar or bipolar mode, enable or disable the buffer, enable or disable the burnout currents, select the gain and select the analog input channel. Table 11 outlines the bit designations for the filter register. CON0 through CON15 indicate the bit locations, CON denoting the bits are in the configuration register. CON15 denotes the first bit of the data stream. The number in brackets indicates the power-on/reset default status of that bit.

CON15	CON14	CON13	CON12	CON11	CON10	CON9	CON8
VBIAS1(0)	VBIAS0(0)	BO(0)	U/B (0)	0(0)	G2(1)	G1(1)	G0(1)
CON7	CON6	CON5	CON4	CON3	CON2	CON1	CON0
REFSEL1(0)	REFSEL0(0)	REF_DET(0)	BUF(1)	CH3(0)	CH2(0)	CH1(0)	CH0(0)

Table 11. Configuration Register Bit Designations

Bit Location	Bit Name	Description																																													
CON15– CON14	0	<p>Bias Voltage Generator Enable. The negative terminal of the analog inputs can be biased up to VDD/2.</p> <table border="1"> <thead> <tr> <th>VBIAS1</th> <th>VBIAS0</th> <th>Bias Voltage</th> </tr> </thead> <tbody> <tr> <td>0</td> <td>0</td> <td>Bias Voltage Generator Disabled</td> </tr> <tr> <td>0</td> <td>1</td> <td>Bias Voltage Generator connected to AIN1(-)</td> </tr> <tr> <td>1</td> <td>0</td> <td>Bias Voltage Generator connected to AIN2(-)</td> </tr> <tr> <td>1</td> <td>1</td> <td>Bias Voltage Generator connected to AIN3(-)</td> </tr> </tbody> </table>	VBIAS1	VBIAS0	Bias Voltage	0	0	Bias Voltage Generator Disabled	0	1	Bias Voltage Generator connected to AIN1(-)	1	0	Bias Voltage Generator connected to AIN2(-)	1	1	Bias Voltage Generator connected to AIN3(-)																														
VBIAS1	VBIAS0	Bias Voltage																																													
0	0	Bias Voltage Generator Disabled																																													
0	1	Bias Voltage Generator connected to AIN1(-)																																													
1	0	Bias Voltage Generator connected to AIN2(-)																																													
1	1	Bias Voltage Generator connected to AIN3(-)																																													
CON13	BO	<p>This bit must be programmed with a Logic 0 for correct operation.</p> <p>Burnout Current Enable Bit. When this bit is set to 1 by the user, the 100 nA current sources in the signal path are enabled. When BO = 0, the burnout currents are disabled. The burnout currents can be enabled only when the buffer or in-amp is active.</p>																																													
CON12	U $\bar{B}$	<p>Unipolar/Bipolar Bit. Set by user to enable unipolar coding, i.e., zero differential input will result in 0x000000 output and a full-scale differential input will result in 0xFFFF output. Cleared by the user to enable bipolar coding. Negative full-scale differential input will result in an output code of 0x000000, zero differential input will result in an output code of 0x800000, and a positive full-scale differential input will result in an output code of 0xFFFF.</p>																																													
CON11 CON10– CON8	0 G2-G0	<p>This bit must be programmed with a Logic 0 for correct operation.</p> <p>Gain Select Bits.</p> <p>Written by the user to select the ADC input range as follows</p> <table border="1"> <thead> <tr> <th>G2</th> <th>G1</th> <th>G0</th> <th>Gain</th> <th>ADC Input Range (2.5V Reference)</th> </tr> </thead> <tbody> <tr> <td>0</td> <td>0</td> <td>0</td> <td>1 (In-Amp not used)</td> <td>2.5 V</td> </tr> <tr> <td>0</td> <td>0</td> <td>1</td> <td>2 (In-Amp not used)</td> <td>1.25 V</td> </tr> <tr> <td>0</td> <td>1</td> <td>0</td> <td>4</td> <td>625 mV</td> </tr> <tr> <td>0</td> <td>1</td> <td>1</td> <td>8</td> <td>312.5 mV</td> </tr> <tr> <td>1</td> <td>0</td> <td>0</td> <td>16</td> <td>156.2 mV</td> </tr> <tr> <td>1</td> <td>0</td> <td>1</td> <td>32</td> <td>78.125 mV</td> </tr> <tr> <td>1</td> <td>1</td> <td>0</td> <td>64</td> <td>39.06 mV</td> </tr> <tr> <td>1</td> <td>1</td> <td>1</td> <td>128</td> <td>19.53 mV</td> </tr> </tbody> </table>	G2	G1	G0	Gain	ADC Input Range (2.5V Reference)	0	0	0	1 (In-Amp not used)	2.5 V	0	0	1	2 (In-Amp not used)	1.25 V	0	1	0	4	625 mV	0	1	1	8	312.5 mV	1	0	0	16	156.2 mV	1	0	1	32	78.125 mV	1	1	0	64	39.06 mV	1	1	1	128	19.53 mV
G2	G1	G0	Gain	ADC Input Range (2.5V Reference)																																											
0	0	0	1 (In-Amp not used)	2.5 V																																											
0	0	1	2 (In-Amp not used)	1.25 V																																											
0	1	0	4	625 mV																																											
0	1	1	8	312.5 mV																																											
1	0	0	16	156.2 mV																																											
1	0	1	32	78.125 mV																																											
1	1	0	64	39.06 mV																																											
1	1	1	128	19.53 mV																																											
CON7– CON6	REFSEL1/REFSELO	<p>Reference Select Bits. The reference source for the ADC is selected using these bits.</p> <table border="1"> <thead> <tr> <th>REFSEL1</th> <th>REFSELO</th> <th>Reference Source</th> </tr> </thead> <tbody> <tr> <td>0</td> <td>0</td> <td>External Reference applied between REFIN1(+) and REFIN1(-)</td> </tr> <tr> <td>0</td> <td>1</td> <td>External Reference applied between REFIN2(+) and REFIN2(-)</td> </tr> <tr> <td>1</td> <td>0</td> <td>Internal 1.17 V Reference</td> </tr> <tr> <td>1</td> <td>1</td> <td>Reserved</td> </tr> </tbody> </table>	REFSEL1	REFSELO	Reference Source	0	0	External Reference applied between REFIN1(+) and REFIN1(-)	0	1	External Reference applied between REFIN2(+) and REFIN2(-)	1	0	Internal 1.17 V Reference	1	1	Reserved																														
REFSEL1	REFSELO	Reference Source																																													
0	0	External Reference applied between REFIN1(+) and REFIN1(-)																																													
0	1	External Reference applied between REFIN2(+) and REFIN2(-)																																													
1	0	Internal 1.17 V Reference																																													
1	1	Reserved																																													
CON5	REF_DET	<p>Enables the Reference Detect Function.</p> <p>When set, the NOXREF bit in the status register indicates when the external reference being used by the ADC is open circuit or less than 0.5 V.</p> <p>When cleared, the reference detect function is disabled.</p>																																													
CON4	BUF	<p>Configures the ADC for buffered or unbuffered mode of operation. If cleared, the ADC operates in unbuffered mode, lowering the power consumption of the device. If set, the ADC operates in buffered mode, allowing the user to place source impedances on the front end without contributing gain errors to the system. For gains of 1 and 2, the buffer can be enabled or disabled. For higher gains, the buffer is automatically enabled.</p>																																													
CON3– CON0	CH3-CH0	<p>Channel Select bits.</p> <p>Written by the user to select the active analog input channel to the ADC.</p> <table border="1"> <thead> <tr> <th>CH3</th> <th>CH2</th> <th>CH1</th> <th>CH0</th> <th>Channel</th> <th>Calibration Pair</th> </tr> </thead> <tbody> <tr> <td>0</td> <td>0</td> <td>0</td> <td>0</td> <td>AIN1(+) – AIN1(-)</td> <td>0</td> </tr> <tr> <td>0</td> <td>0</td> <td>0</td> <td>1</td> <td>AIN2(+) – AIN2(-)</td> <td>1</td> </tr> <tr> <td>0</td> <td>0</td> <td>1</td> <td>0</td> <td>AIN3(+) – AIN3(-)</td> <td>2</td> </tr> <tr> <td>0</td> <td>0</td> <td>1</td> <td>1</td> <td>AIN4(+) – AIN4(-)</td> <td>3</td> </tr> </tbody> </table>	CH3	CH2	CH1	CH0	Channel	Calibration Pair	0	0	0	0	AIN1(+) – AIN1(-)	0	0	0	0	1	AIN2(+) – AIN2(-)	1	0	0	1	0	AIN3(+) – AIN3(-)	2	0	0	1	1	AIN4(+) – AIN4(-)	3															
CH3	CH2	CH1	CH0	Channel	Calibration Pair																																										
0	0	0	0	AIN1(+) – AIN1(-)	0																																										
0	0	0	1	AIN2(+) – AIN2(-)	1																																										
0	0	1	0	AIN3(+) – AIN3(-)	2																																										
0	0	1	1	AIN4(+) – AIN4(-)	3																																										

Bit Location	Bit Name	Description					
		0	1	0	0	AIN5(+)- AIN5(-)	3
		0	1	0	1	AIN6(+)- AIN6(-)	3
		0	1	1	0	Temp Sensor	Automatically selects the internal reference and sets the gain to 1
		0	1	1	1	VDD Monitor	Automatically selects the internal 1.17 V reference and sets the gain to 1/6
		1	0	0	0	AIN1(-)- AIN1(-)	0
		1	0	0	1	Reserved	
		1	0	1	0	Reserved	
		1	0	1	1	Reserved	
		1	1	0	0	Reserved	
		1	1	0	1	Reserved	
		1	1	1	0	Reserved	
		1	1	1	1	Reserved	

#### DATA REGISTER (RS2, RS1, RS0 = 0, 1, 1; POWER-ON/RESET = 0x000000)

The conversion result from the ADC is stored in this data register. This is a read-only register. On completion of a read operation from this register, the RDY bit/pin is set.

#### ID REGISTER (RS2, RS1, RS0 = 1, 0, 0; POWER-ON/RESET = 0xXF)

The Identification Number for the AD7794 is stored in the ID register. This is a read-only register.

#### IO REGISTER (RS2, RS1, RS0 = 1, 0, 1; POWER-ON/RESET = 0x00)

The I/O register is an 8-bit register from which data can be read or to which data can be written. This register is used to enable the excitation currents and select the value of the excitation currents. Table 12 outlines the bit designations for the IO register. IO0 through IO7 indicate the bit locations, IO denoting the bits are in the IO register. IO7 denotes the first bit of the data stream. The number in brackets indicates the power-on/reset default status of that bit.

IO7	IO6	IO5	IO4	IO3	IO2	IO1	IO0
0(0)	IOEN(0)	IO2DAT(0)	IO1DAT(0)	IEXCDIR1(0)	IEXCDIR0(0)	IEXCEN1(0)	IEXCEN0(0)

Table 12 Filter Register Bit Designations

Bit Location	Bit Name	Description															
IO7	0	This bit must be programmed with a Logic 0 for correct operation.															
IO6	IOEN	Configures the pins AIN6(+)/P2 and AIN6(-)/P2 are analog input pins or digital output pins. When this bit is <i>set</i> , the pins are configured as digital output pins P1 and P2. When this bit is <i>cleared</i> , these pins are configured as analog input pins AIN6(+) and AIN6(-).															
IO5-IO4	IO2DAT/IO1DAT	P2/P1 Data. When IOEN is set, the data for the digital output pins P1 and P2 is written to bits IO2DAT and IO1DAT.															
IO3-IO2	IEXCDIR1- IEXCDIR0	Direction of Current Sources Select bits. <table border="1"> <thead> <tr> <th>IEXCDIR1</th> <th>IEXCDIR0</th> <th>Current Source Direction</th> </tr> </thead> <tbody> <tr> <td>0</td> <td>0</td> <td>Current Source IEXC1 connected to pin IOOUT1, Current Source IEXC2 connected to pin IOOUT2</td> </tr> <tr> <td>0</td> <td>1</td> <td>Current Source IEXC1 connected to pin IOOUT2, Current Source IEXC2 connected to pin IOOUT1</td> </tr> <tr> <td>1</td> <td>0</td> <td>Both Current Sources connected to pin IOOUT1. Permitted only when the current sources are set to 10 uA or 200 uA</td> </tr> <tr> <td>1</td> <td>1</td> <td>Both Current Sources connected to pin IOOUT2. Permitted only when the current sources are set to 10 uA or 200 uA</td> </tr> </tbody> </table>	IEXCDIR1	IEXCDIR0	Current Source Direction	0	0	Current Source IEXC1 connected to pin IOOUT1, Current Source IEXC2 connected to pin IOOUT2	0	1	Current Source IEXC1 connected to pin IOOUT2, Current Source IEXC2 connected to pin IOOUT1	1	0	Both Current Sources connected to pin IOOUT1. Permitted only when the current sources are set to 10 uA or 200 uA	1	1	Both Current Sources connected to pin IOOUT2. Permitted only when the current sources are set to 10 uA or 200 uA
IEXCDIR1	IEXCDIR0	Current Source Direction															
0	0	Current Source IEXC1 connected to pin IOOUT1, Current Source IEXC2 connected to pin IOOUT2															
0	1	Current Source IEXC1 connected to pin IOOUT2, Current Source IEXC2 connected to pin IOOUT1															
1	0	Both Current Sources connected to pin IOOUT1. Permitted only when the current sources are set to 10 uA or 200 uA															
1	1	Both Current Sources connected to pin IOOUT2. Permitted only when the current sources are set to 10 uA or 200 uA															
IO3-IO2	IEXCEN1-	These bits are used to enable and disable the current sources along with selecting the value of the															

Bit Location	Bit Name	Description															
	IEXCEN0	excitation currents.															
		<table border="1"> <thead> <tr> <th>IEXCEN1</th> <th>IEXCEN0</th> <th>Current Source Value</th> </tr> </thead> <tbody> <tr> <td>0</td> <td>0</td> <td>Excitation Currents Disabled</td> </tr> <tr> <td>0</td> <td>1</td> <td>10 <math>\mu</math>A</td> </tr> <tr> <td>1</td> <td>0</td> <td>200 <math>\mu</math>A</td> </tr> <tr> <td>1</td> <td>1</td> <td>1 mA</td> </tr> </tbody> </table>	IEXCEN1	IEXCEN0	Current Source Value	0	0	Excitation Currents Disabled	0	1	10 $\mu$ A	1	0	200 $\mu$ A	1	1	1 mA
IEXCEN1	IEXCEN0	Current Source Value															
0	0	Excitation Currents Disabled															
0	1	10 $\mu$ A															
1	0	200 $\mu$ A															
1	1	1 mA															

**OFFSET REGISTER (RS2, RS1, RS0 = 1, 1, 0; POWER-ON/RESET = 0x800000)**

The offset register holds the offset calibration coefficient for the ADC. The power-on-reset value of the internal zero-scale calibration coefficient register is 800000 hex. The AD7794 has 4 offset registers. Channels AIN1 to AIN3 have dedicated offset registers while channels AIN4, AIN5 and AIN6 share an offset register. Each of these registers is a 24-bit read/write register. This register is used in conjunction with its associated full-scale register to form a register pair. The power-on-reset value is automatically overwritten if an internal or system zero-scale calibration is initiated by the user. The AD7794 must be placed in power down mode or idle mode when writing to the offset register.

**FULL-SCALE REGISTER (RS2, RS1, RS0 = 1, 1, 1; POWER-ON/RESET = 0x5XXXX5)**

The full-scale registers is a 24-bit register that holds the full-scale calibration coefficient for the ADC. The AD7794 has 4 full-scale registers. Channels AIN1, AIN2 and AIN3 have dedicated full-scale registers while channels AIN4, AIN5 and AIN6 share a register. The full-scale registers are read/write registers. However, when writing to the full-scale registers, the ADC must be placed in power down mode or idle mode. These registers are configured on power-on with factory-calibrated internal full-scale calibration coefficients, the factory calibration being performed with the gain set to 1 and using the internal reference. Therefore, every device will have different default coefficients. These default values are used when the device is operated with a gain of 1 and when the internal reference is selected. For other gains or when the external reference is used at a gain of 1, these default coefficients will be automatically overwritten if an internal or system full-scale calibration is initiated by the user. A full-scale calibration should be performed when the gain is changed.

TYPICAL APPLICATION (FLOWMETER)

