

### FEATURES

Optimized for Fiber Optic Photodiode Interfacing  
Eight Full Decades of Range

Law Conformance 0.1 dB from 1 nA to 1 mA  
Single-Supply Operation (3.0 V– 5.5 V)  
Complete and Temperature Stable

Accurate Laser-Trimmed Scaling:

Logarithmic Slope of 10 mV/dB (at VLOG Pin)  
Basic Logarithmic Intercept at 100 pA  
Easy Adjustment of Slope and Intercept  
Output Bandwidth of 10 MHz, 15 V/ $\mu$ s Slew Rate  
1-, 2-, or 3-Pole Low-Pass Filtering at Output  
Miniature 14-Lead Package (TSSOP)  
Low Power: ~4.5 mA Quiescent Current (Enabled)

### APPLICATIONS

High Accuracy Optical Power Measurement  
Wide Range Baseband Log Compression  
Versatile Detector for APC Loops

### PRODUCT DESCRIPTION

The AD8304 is a monolithic logarithmic detector optimized for the measurement of low frequency signal power in fiber optic systems. It uses an advanced translinear technique to provide an exceptionally large dynamic range in a versatile and easily used form. Its wide measurement range and accuracy are achieved using proprietary design techniques and precise laser trimming. In most applications only a single positive supply,  $V_P$ , of 5 V will be required, but 3.0 V to 5.5 V can be used, and certain applications benefit from the added use of a negative supply,  $V_N$ . When using low supply voltages, the log slope is readily altered to fit the available span. The low quiescent current and chip disable features facilitate use in battery-operated applications.

The input current,  $I_{PD}$ , flows in the collector of an optimally scaled NPN transistor, connected in a feedback path around a low offset JFET amplifier. The current-summing input node operates at a constant voltage, independent of current, with a default value of 0.5 V; this may be adjusted over a wide range, including ground or below, using an optional negative supply. An adaptive biasing scheme is provided for reducing the dark current at very low light input levels. The voltage at Pin VPDB applies approximately 0.1 V across the diode for  $I_{PD} = 100$  pA, rising linearly with current to 2.0 V of net bias at  $I_{PD} = 10$  mA. The input pin INPT is flanked by the guard pins VSUM that track the voltage at the summing node to minimize leakage.

### REV. A

Information furnished by Analog Devices is believed to be accurate and reliable. However, no responsibility is assumed by Analog Devices for its use, nor for any infringements of patents or other rights of third parties that may result from its use. No license is granted by implication or otherwise under any patent or patent rights of Analog Devices.

### FUNCTIONAL BLOCK DIAGRAM

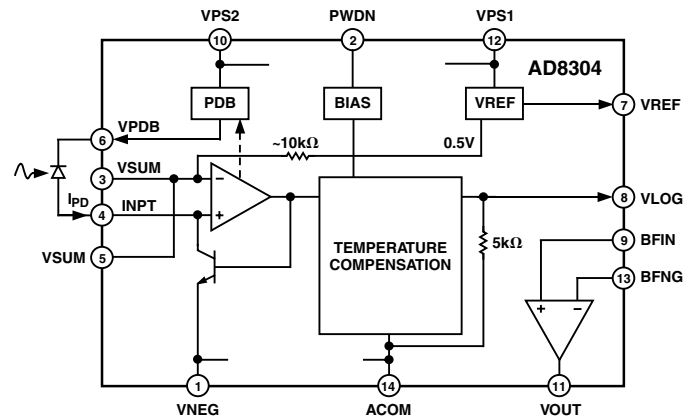

The default value of the logarithmic slope at the output VLOG is accurately scaled to 10 mV/dB (200 mV/decade). The resistance at this output is laser-trimmed to 5 k $\Omega$ , allowing the slope to be lowered by shunting it with an external resistance; the addition of a capacitor at this pin provides a simple low-pass filter. The intermediate voltage VLOG is buffered in an output stage that can swing to within about 100 mV of ground (or  $V_N$ ) and the positive supply,  $V_P$ , and provides a peak current drive capacity of  $\pm 20$  mA. The slope can be increased using the buffer and a pair of external feedback resistors. An accurate voltage reference of 2 V is also provided to facilitate the repositioning of the intercept.

Many operational modes are possible. For example, low-pass filters of up to three poles may be implemented, to reduce the output noise at low input currents. The buffer may also serve as a comparator, with or without hysteresis, using the 2 V reference, for example, in alarm applications. The incremental bandwidth of a translinear logarithmic amplifier inherently diminishes for small input currents. At the 1 nA level, the AD8304's bandwidth is about 2 kHz, but this increases in proportion to  $I_{PD}$  up to a maximum value of 10 MHz.

The AD8304 is available in a 14-lead TSSOP package and specified for operation from  $-40^\circ\text{C}$  to  $+85^\circ\text{C}$ .

# AD8304—SPECIFICATIONS ( $V_P = 5\text{ V}$ , $V_N = 0\text{ V}$ , $T_A = 25^\circ\text{C}$ , unless otherwise noted.)

Parameter	Conditions	Min <sup>1</sup>	Typ	Max <sup>1</sup>	Unit
INPUT INTERFACE	Pin 4, INPT; Pin 3 and Pin 5, VSUM				
Specified Current Range	Flows toward INPT Pin	100			pA
Input Node Voltage	Internally preset; may be altered	0.46	0.5	10	mA
Temperature Drift	$-40^\circ\text{C} < T_A < +85^\circ\text{C}$		0.02	0.54	V
Input Guard Offset Voltage	$V_{IN} - V_{SUM}$	-20		+20	mV/°C
PHOTODIODE BIAS <sup>2</sup>	Established between Pin 6, $V_{PDB}$ , and Pin 4				
Minimum Value	$I_{PD} = 100\text{ pA}$	70	100		mV
Transresistance			200		mV/mA
LOGARITHMIC OUTPUT	Pin 8, VLOG				
Slope	Laser-trimmed at $25^\circ\text{C}$	196	200	204	mV/dec
	$0^\circ\text{C} < T_A < 70^\circ\text{C}$	194		207	mV/dec
Intercept	Laser-trimmed at $25^\circ\text{C}$	60	100	140	pA
	$0^\circ\text{C} < T_A < 70^\circ\text{C}$	35		175	pA
Law Conformance Error	$10\text{ nA} < I_{PD} < 1\text{ mA}$ , Peak Error		0.05	0.25	dB
	$1\text{ nA} < I_{PD} < 1\text{ mA}$ , Peak Error		0.1	0.7	dB
Maximum Output Voltage			1.6		V
Minimum Output Voltage	Limited by $V_N = 0\text{ V}$		0.1		V
Output Resistance	Laser-trimmed at $25^\circ\text{C}$	4.95	5	5.05	k $\Omega$
REFERENCE OUTPUT	Pin 7, VREF				
Voltage WRT Ground	Laser-trimmed at $25^\circ\text{C}$	1.98	2	2.02	V
	$-40^\circ\text{C} < T_A < +85^\circ\text{C}$	1.92		2.08	V
Output Resistance			2		$\Omega$
OUTPUT BUFFER	Pin 9, BFIN; Pin 13, BFNG; Pin 11, VOUT				
Input Offset Voltage		-20		+20	mV
Input Bias Current	Flowing out of Pin 9 or Pin 13		0.4		$\mu\text{A}$
Incremental Input Resistance			35		M $\Omega$
Output Range	$R_L = 1\text{ k}\Omega$ to ground		$V_P - 0.1$		V
Output Resistance			0.5		$\Omega$
Wide-Band Noise <sup>3</sup>	$I_{PD} > 1\text{ }\mu\text{A}$ (see Typical Performance Characteristics)		1		$\mu\text{V}/\sqrt{\text{Hz}}$
Small Signal Bandwidth <sup>3</sup>	$I_{PD} > 1\text{ }\mu\text{A}$ (see Typical Performance Characteristics)		10		MHz
Slew Rate	0.2 V to 4.8 V output swing		15		V/ $\mu\text{s}$
POWER-DOWN INPUT	Pin 2, PWDN				
Logic Level, HI State	$-40^\circ\text{C} < T_A < +85^\circ\text{C}$ , $2.7\text{ V} < V_P < 5.5\text{ V}$	2			V
Logic Level, LO State	$-40^\circ\text{C} < T_A < +85^\circ\text{C}$ , $2.7\text{ V} < V_P < 5.5\text{ V}$			1	V
POWER SUPPLY	Pin 10 and Pin 12, VPS1 and VPS2; Pin 1, VNEG				
Positive Supply Voltage		3.0	5	5.5	V
Quiescent Current			4.5	5.3	mA
In Disabled State			60		$\mu\text{A}$
Negative Supply Voltage <sup>4</sup>	$ 1V_P - V_N  < 8\text{ V}$		0	-5.5	V

## NOTES

<sup>1</sup>Minimum and maximum specified limits on parameters that are guaranteed but not tested are six sigma values.

<sup>2</sup>This bias is internally arranged to track the input voltage at INPT; it is not specified relative to ground.

<sup>3</sup>Output Noise and Incremental Bandwidth are functions of Input Current; see Typical Performance Characteristics.

<sup>4</sup>Optional

Specifications subject to change without notice.

### ABSOLUTE MAXIMUM RATINGS\*

Supply Voltage $V_P - V_N$ .....	8 V
Input Current .....	20 mA
Internal Power Dissipation .....	270 mW
$\theta_{JA}$ .....	150°C/W
Maximum Junction Temperature .....	125°C
Operating Temperature Range .....	-40°C to +85°C
Storage Temperature Range .....	-65°C to +150°C
Lead Temperature Range (Soldering 60 sec) .....	300°C

\*Stresses above those listed under Absolute Maximum Ratings may cause permanent damage to the device. This is a stress rating only; functional operation of the device at these or any other conditions above those indicated in the operational section of this specification is not implied. Exposure to absolute maximum rating conditions for extended periods may affect device reliability.

### PIN CONFIGURATION

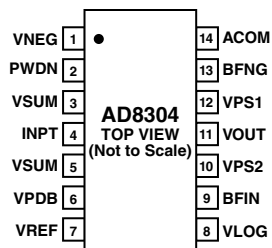

### PIN FUNCTION DESCRIPTIONS

Pin No.	Mnemonic	Function
1	VNEG	Optional Negative Supply, $V_N$ . This pin is usually grounded; for details of usage, see Applications section.
2	PWDN	Power-Down Control Input. Device is active when PWDN is taken LOW.
3, 5	VSUM	Guard Pins. Used to shield the INPT current line.
4	INPT	Photodiode Current Input. Usually connected to photodiode anode (the photo current flows toward INPT).
6	VPDB	Photodiode Biased Output. May be connected to photodiode cathode to provide adaptive bias control.
7	VREF	Voltage Reference Output of 2 V
8	VLOG	Output of the Logarithmic Front-End Processor; $R_{OUT} = 5\text{ k}\Omega$ to ground.
9	BFIN	Buffer Amplifier Noninverting Input (High Impedance)
10	VPS2	Positive Supply, $V_P$ (3.0 V to 5.5 V)
11	VOUT	Buffer Output; Low Impedance
12	VPS1	Positive Supply, $V_P$ (3.0 V to 5.5 V)
13	BFNG	Buffer Amplifier Inverting Input
14	ACOM	Analog Ground

### ORDERING GUIDE

Model	Temperature Range	Package Description	Package Option
AD8304ARU AD8304ARU-REEL AD8304ARU-REEL7 AD8304-EVAL	-40°C to +85°C	Tube, 14-Lead TSSOP 13" Tape and Reel 7" Tape and Reel Evaluation Board	RU-14

### CAUTION

ESD (electrostatic discharge) sensitive device. Electrostatic charges as high as 4000 V readily accumulate on the human body and test equipment and can discharge without detection. Although the AD8304 features proprietary ESD protection circuitry, permanent damage may occur on devices subjected to high energy electrostatic discharges. Therefore, proper ESD precautions are recommended to avoid performance degradation or loss of functionality.



# AD8304—Typical Performance Characteristics

( $V_P = 5\text{ V}$ ,  $V_N = 0\text{ V}$ ,  $T_A = 25^\circ\text{C}$ , unless otherwise noted.)

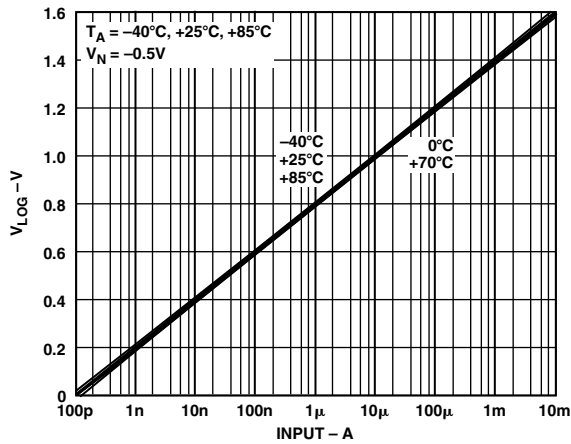

TPC 1.  $V_{LOG}$  vs.  $I_{PD}$

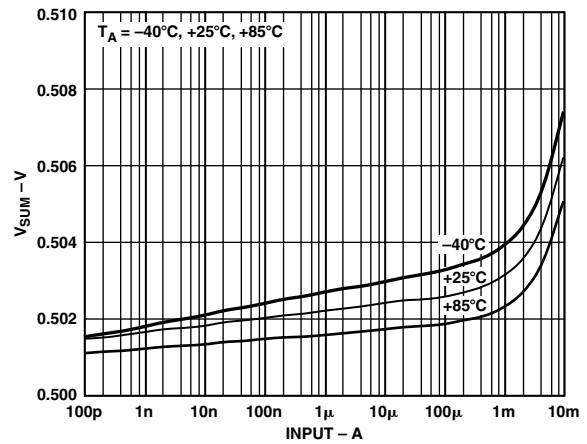

TPC 4.  $V_{SUM}$  vs.  $I_{PD}$

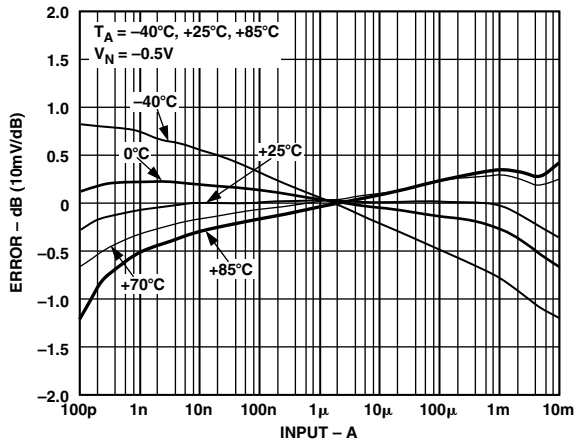

TPC 2. Logarithmic Conformance (Linearity) for  $V_{LOG}$

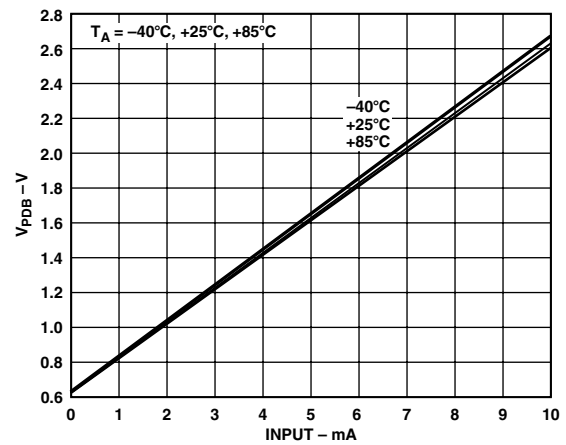

TPC 5.  $V_{PDB}$  vs.  $I_{PD}$

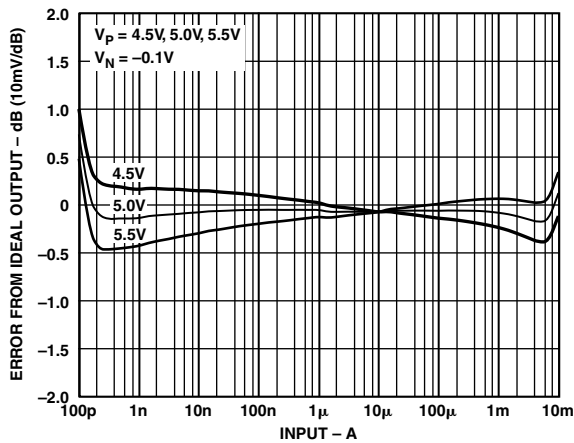

TPC 3. Absolute Deviation from Nominal Specified Value of  $V_{LOG}$  for Several Supply Voltages

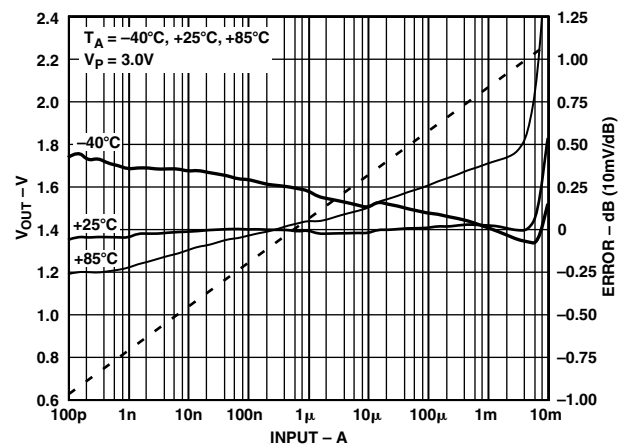

TPC 6. Logarithmic Conformance (Linearity) for a 3 V Single Supply (See Figure 6)

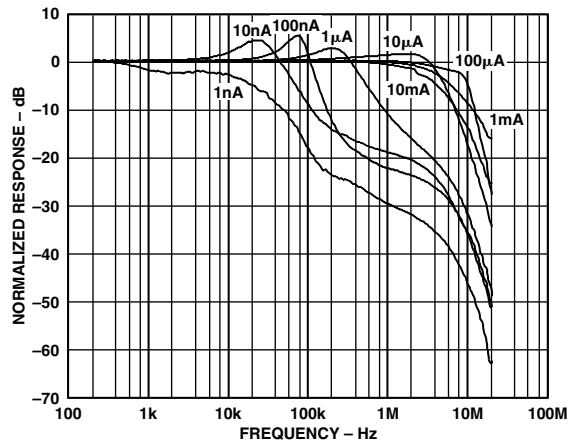

TPC 7. Small Signal AC Response,  $I_{PD}$  to  $V_{LOG}$  (5% Sine Modulation of  $I_{PD}$  at Frequency)

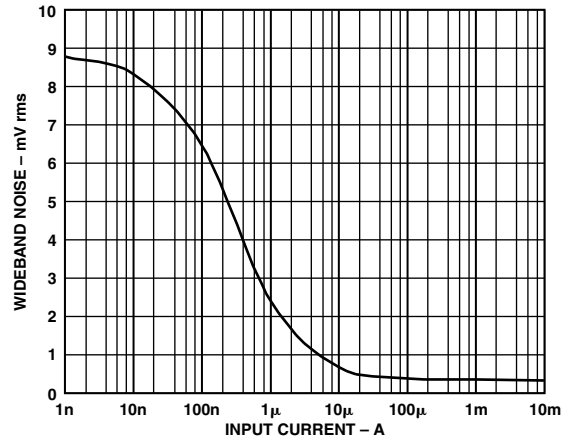

TPC 10. Total Wideband Noise Voltage at  $V_{LOG}$  vs.  $I_{PD}$

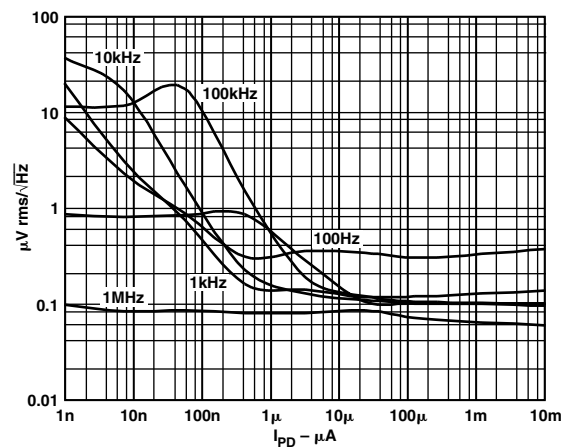

TPC 8. Spot Noise Spectral Density at  $V_{LOG}$  vs.  $I_{PD}$

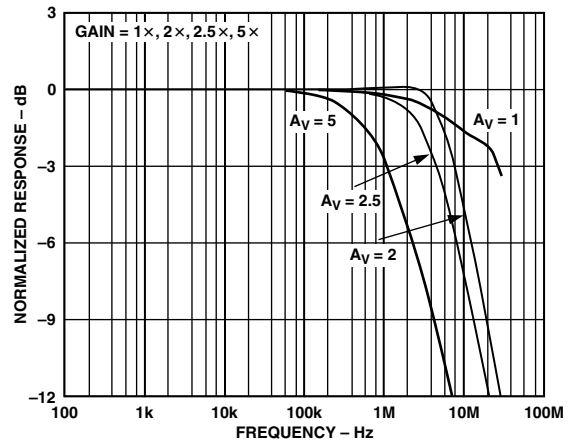

TPC 11. Small Signal Response of Buffer

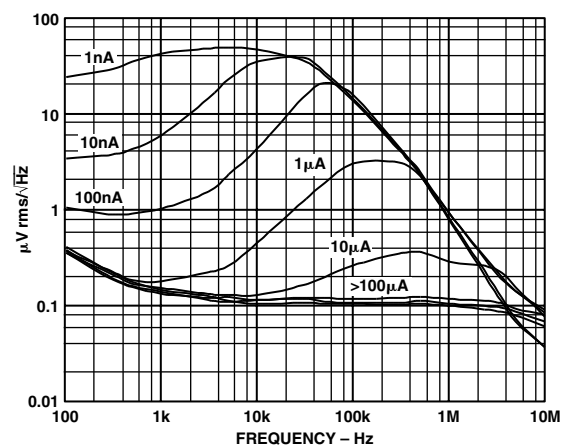

TPC 9. Spot Noise Spectral Density at  $V_{LOG}$  vs. Frequency

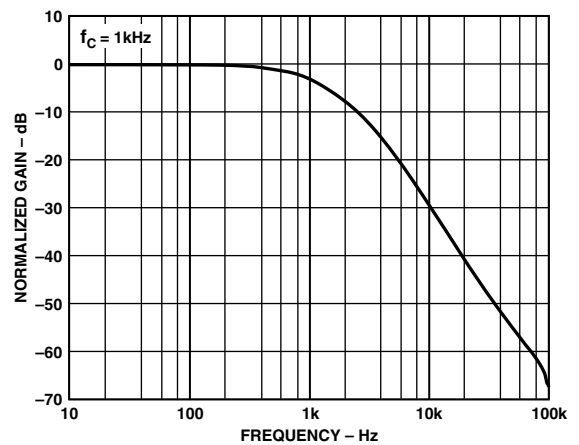

TPC 12. Small Signal Response of Buffer Operating as Two-Pole Filter

# AD8304

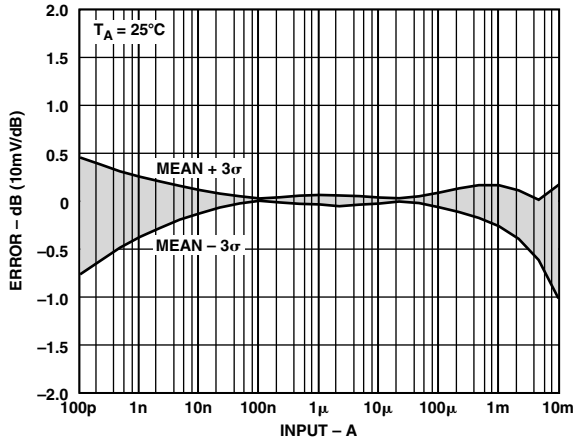

TPC 13. Logarithmic Conformance Error Distribution ( $3\sigma$  to Either Side of Mean)

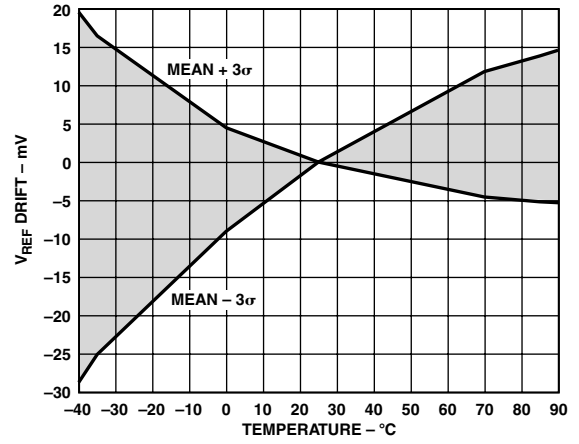

TPC 16.  $V_{REF}$  Drift vs. Temperature ( $3\sigma$  to Either Side of Mean)

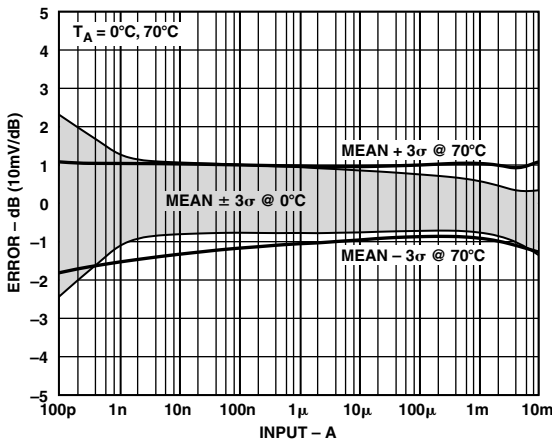

TPC 14. Logarithmic Conformance Error Distribution ( $3\sigma$  to Either Side of Mean)

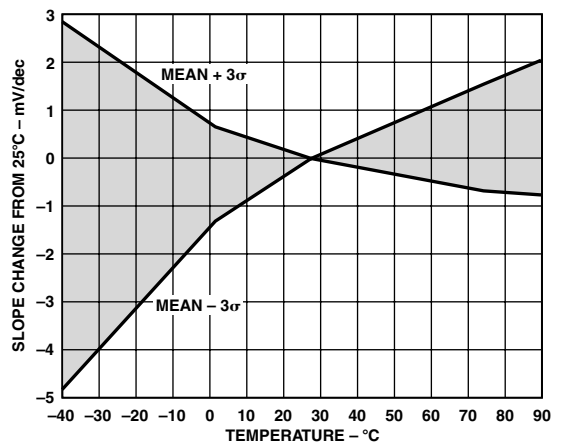

TPC 17. Slope Drift vs. Temperature ( $3\sigma$  to Either Side of Mean)

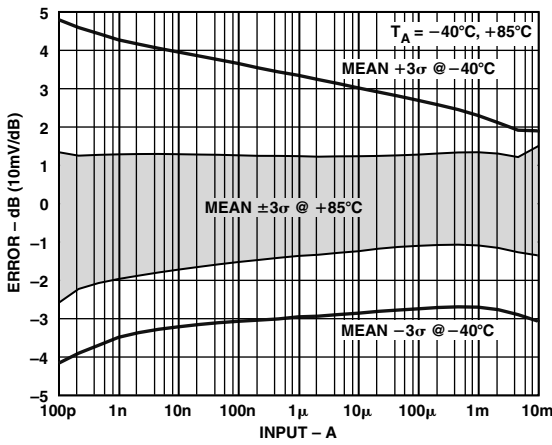

TPC 15. Logarithmic Conformance Error Distribution ( $3\sigma$  to Either Side of Mean)

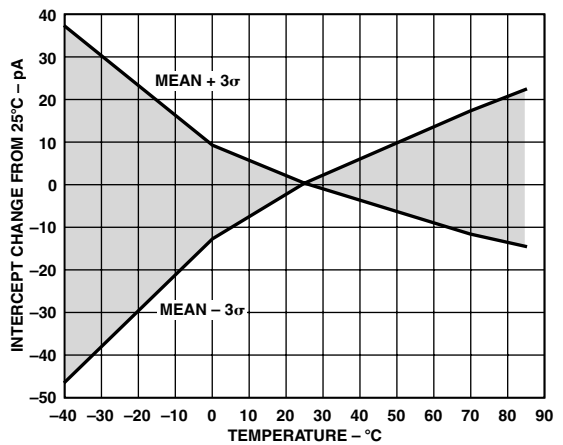

TPC 18. Intercept Drift vs. Temperature ( $3\sigma$  to Either Side of Mean)

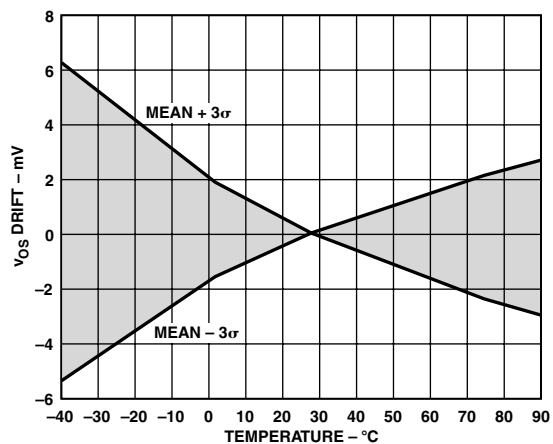

TPC 19. Output Buffer Offset vs. Temperature (3σ to Either Side of Mean)

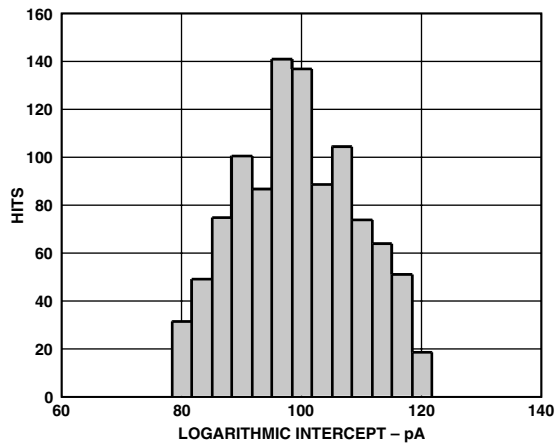

TPC 21. Distribution of Logarithmic Intercept, Sample 1000

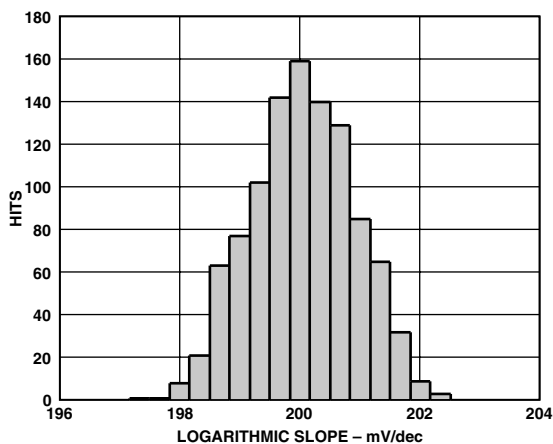

TPC 20. Distribution of Logarithmic Slope, Sample 1000

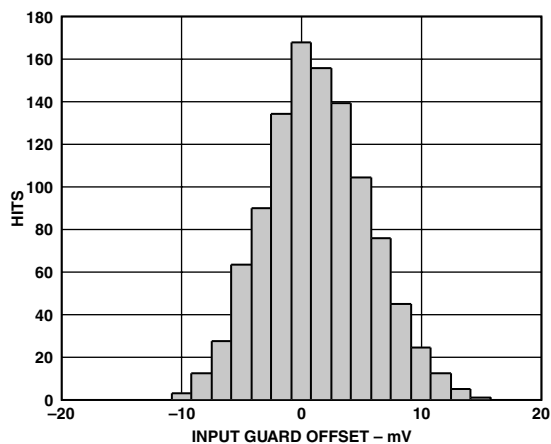

TPC 22. Distribution of Input Guard Offset Voltage ( $V_{INPT} - V_{SUM}$ ), Sample 1000

# AD8304

## BASIC CONCEPTS

The AD8304 uses an advanced circuit implementation that exploits the well known logarithmic relationship between the base-to-emitter voltage,  $V_{BE}$ , and collector current,  $I_C$ , in a bipolar transistor, which is the basis of the important class of translinear circuits\*:

$$V_{BE} = V_T \log(I_C/I_S) \quad (1)$$

There are two scaling quantities in this fundamental equation, namely the thermal voltage  $V_T = kT/q$  and the saturation current  $I_S$ . These are of key importance in determining the slope and intercept for this class of log amp.  $V_T$  has a process-invariant value of 25.69 mV at  $T = 25^\circ\text{C}$  and varies in direct proportion to absolute temperature, while  $I_S$  is very much a process- and device-dependent parameter, and is typically  $10^{-16}$  A at  $T = 25^\circ\text{C}$  but exhibits a huge variation over the temperature range, by a factor of about a billion.

While these variations pose challenges to the use of a transistor as an accurate measurement device, the remarkable matching and isothermal properties of the components in a monolithic process can be applied to reduce them to insignificant proportions, as will be shown. Logarithmic amplifiers based on this unique property of the bipolar transistor are called translinear log amps to distinguish them from other Analog Devices products designed for RF applications that use quite different principles.

The very strong temperature variation of the saturation current  $I_S$  is readily corrected using a second reference transistor, having an identical variation, to stabilize the intercept. Similarly, proprietary techniques are used to ensure that the logarithmic slope is temperature-stable. Using these principles in a carefully scaled design, the now accurate relationship between the input current,  $I_{PD}$ , applied to Pin INPT, and the voltage appearing at the intermediate output Pin VLOG is:

$$V_{LOG} = V_Y \log_{10}(I_{PD}/I_Z) \quad (2)$$

$V_Y$  is called the slope voltage (in the case of base-10 logarithms, it is also the “volts per decade”). The fixed current  $I_Z$  is called the intercept. The scaling is chosen so that  $V_Y$  is trimmed to 200 mV/decade (10 mV/dB). The intercept is positioned at 100 pA; the output voltage  $V_{LOG}$  would cross zero when  $I_{PD}$  is of this value. However, when using a single supply the actual  $V_{LOG}$  must always be slightly above ground. On the other hand, by using a negative supply, this voltage can actually cross zero at the intercept value.

Using Equation 2, one can calculate the output for any value of  $I_{PD}$ . Thus, for an input current of 25 nA,

$$V_{LOG} = 0.2 V \log_{10}(25 \text{ nA}/100 \text{ pA}) = 0.4796 V \quad (3)$$

In practice, both the slope and intercept may be altered, to either higher or lower values, without any significant loss of calibration accuracy, by using one or two external resistors, often in conjunction with the trimmed 2 V voltage reference at Pin VREF.

## Optical Measurements

When interpreting the current  $I_{PD}$  in terms of optical power incident on a photodetector, it is necessary to be very clear about the transducer properties of a biased photodiode. The units of this transduction process are expressed as amps per watt. The parameter  $\rho$ , called the photodiode responsivity, is often used for this purpose. For a typical InGaAs p-i-n photodiode, the responsivity is about 0.9 A/W.

It is also important to note that amps and watts are not usually related in this proportional manner. In purely electrical circuits, a current  $I_{PD}$  applied to a resistive load  $R_L$  results in a power proportional to the square of the current (that is,  $I_{PD}^2 R_L$ ). The reason for the difference in scaling for a photodiode interface is that the current  $I_{PD}$  flows in a diode biased to a fixed voltage,  $V_{PDB}$ . In this case, the power dissipated within the detector diode is simply proportional to the current  $I_{PD}$  (that is,  $I_{PD} V_{PDB}$ ) and the proportionality of  $I_{PD}$  to the optical power,  $P_{OPT}$ , is preserved.

$$I_{PD} = \rho P_{OPT} \quad (4)$$

Accordingly, a reciprocal correspondence can be stated between the intercept current,  $I_Z$ , and an equivalent “intercept power,”  $P_Z$ , thus:

$$I_Z = \rho P_Z \quad (5)$$

and Equation 2 may then be written as:

$$V_{LOG} = V_Y \log_{10}(P_{OPT}/P_Z) \quad (6)$$

For the AD8304 operating in its default mode, its  $I_Z$  of 100 pA corresponds to a  $P_Z$  of 110 picowatts, for a diode having a responsivity of 0.9 A/W. Thus, an optical power of 3 mW would generate:

$$V_{LOG} = 0.2 V \log_{10}(3 \text{ mW}/110 \text{ pW}) = 1.487 V \quad (7)$$

Note that when using the AD8304 in optical applications, the interpretation of  $V_{LOG}$  is in terms of the equivalent optical power, the logarithmic slope remains 10 mV/dB at this output. This can be a little confusing since a decibel change on the optical side has a different meaning than on the electrical side. In either case, the logarithmic slope can always be expressed in units of mV per decade to help eliminate any confusion.

## Decibel Scaling

In cases where the power levels are already expressed as so many decibels above a reference level (in dBm, for a reference of 1 mW), the logarithmic conversion has already been performed, and the “log ratio” in the above expressions becomes a simple difference. One needs to be careful in assigning variable names here, because “P” is often used to denote actual power as well as this same power expressed in decibels, while clearly these are numerically different quantities.

Such potential misunderstandings can be avoided by using “D” to denote decibel powers. The quantity  $V_Y$  (“volts per decade”) must now be converted to its decibel value,  $V_Y' = V_Y/10$ , because there are 10 dB per decade in the context of a power measurement. Then it can be stated that:

$$V_{LOG} = 20 (D_{OPT} - D_Z) \text{ mV/dB} \quad (8)$$

where  $D_{OPT}$  is the optical power in decibels above a reference level, and  $D_Z$  is the equivalent intercept power relative to the same level. This convention will be used throughout this data sheet.

\*For a basic discussion of the topic, see Translinear Circuits: An Historical Overview, B. Gilbert, *Analog Integrated Circuits and Signal Processing*, 9, pp. 95–118, 1996.



# AD8304

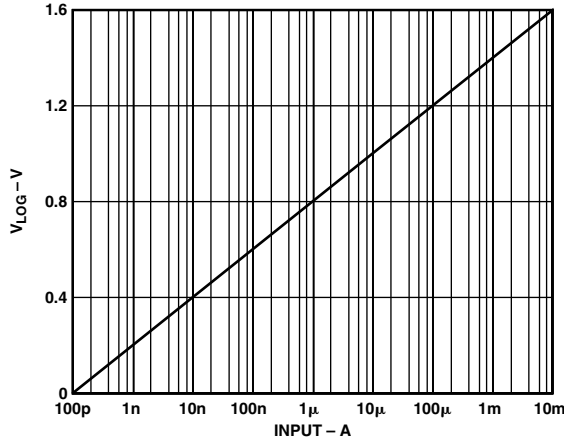

Figure 2. Ideal Form of  $V_{LOG}$  vs.  $I_{PD}$

Using a value of 0.3 pF for  $C_J$  evaluates to 20 MHz/mA. Therefore, the minimum bandwidth at  $I_{PD} = 100$  pA would be 2 kHz. While this simple model is useful in making a point, it excludes other effects that limit its usefulness. For example, the network  $R_1$ ,  $C_1$  in Figure 1, which is necessary to stabilize the system over the full range of currents, affects bandwidth at all values of  $I_{PD}$ . Later signal processing blocks also limit the maximum value.

TPC 7 shows ac response curves for the AD8304 at eight representative currents of 100 pA to 10 mA, using  $R_1 = 750 \Omega$  and  $C_1 = 1000$  pF. The values for  $R_1$  and  $C_1$  ensure stability over the full 160 dB dynamic range. More optimal values may be used for smaller subranges. A certain amount of experimental trial and error may be necessary to select the optimum input network component values for a given application.

Turning now to the noise performance of a translinear log amp, the relationship between  $I_{PD}$  and the voltage noise spectral density,  $S_{NSD}$ , associated with the  $V_{BE}$  of  $Q_1$ , evaluates to the following:

$$S_{NSD} = \frac{14.7}{\sqrt{I_{PD}}} \quad (14)$$

where  $S_{NSD}$  is nV/Hz,  $I_{PD}$  is expressed in microamps and  $T_A = 25^\circ\text{C}$ . For an input of 1 nA,  $S_{NSD}$  evaluates to almost  $0.5 \mu\text{V}/\sqrt{\text{Hz}}$ ; assuming a 20 kHz bandwidth at this current, the integrated noise voltage is 70  $\mu\text{V}$  rms. However, the calculation is not complete. The basic scaling of the  $V_{BE}$  is approximately 3 mV/dB; translated to 10 mV/dB, the noise predicted by Equation 14 must be multiplied by approximately 3.33. The additive noise effects associated with the reference transistor,  $Q_2$ , and the temperature compensation circuitry must also be included. The final voltage noise spectral density presented at the  $V_{LOG}$  Pin varies inversely with  $I_{PD}$ , but not as simple as square root. TPCs 8 and 9 show the measured noise spectral density versus frequency at the  $V_{LOG}$  output, for the same nine-decade spaced values of  $I_{PD}$ .

## Chip Enable

The AD8304 may be powered down by taking the  $PWDN$  Pin to a high logic level. The residual supply current in the disabled mode is typically 60  $\mu\text{A}$ .

## USING THE AD8304

The basic connections (Figure 3) include a 2.5:1 attenuator in the feedback path around the buffer. This increases the basic slope of 10 mV/dB at the  $V_{LOG}$  Pin to 25 mV/dB at  $V_{OUT}$ . For the full dynamic range of 160 dB (80 dB optical), the output swing

is thus 4.0 V, which can be accommodated by the rail-to-rail output stage when using the recommended 5 V supply.

The capacitor from  $V_{LOG}$  to ground forms an optional single-pole low-pass filter. Since the resistance at this pin is trimmed to 5 k $\Omega$ , an accurate time constant can be realized. For example, with  $C_{FLT} = 10$  nF, the  $-3$  dB corner frequency is 3.2 kHz. Such filtering is useful in minimizing the output noise, particularly when  $I_{PD}$  is small. Multipole filters are more effective in reducing noise, and are discussed below. A capacitor between  $VSUM$  and ground is essential for minimizing the noise on this node. When the bias voltage at either  $VPDB$  or  $VREF$  is not needed these pins should be left unconnected.

## Slope and Intercept Adjustments

The choice of slope and intercept depends on the application. The versatility of the AD8304 permits optimal choices to be made in two common situations. First, it allows an input current range of less than the full 160 dB to use the available voltage span at the output. Second, it allows this output voltage range to be optimally positioned to fit the input capacity of a subsequent ADC. In special applications, very high slopes, such as 1 V/dec, allow small subranges of  $I_{PD}$  to be covered at high sensitivity.

The slope can be lowered without limit by the addition of a shunt resistor,  $R_S$ , from  $V_{LOG}$  to ground. Since the resistance at this pin is trimmed to 5 k $\Omega$ , the accuracy of the modified slope will depend on the external resistor. It is calculated using:

$$V_Y = \frac{V_Y R_S}{R'_S + 5 \text{ k}\Omega} \quad (15)$$

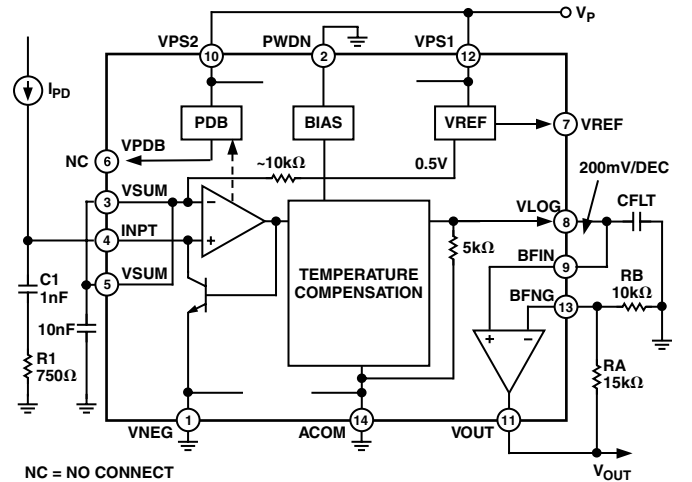

Figure 3. Basic Connections ( $R_A$ ,  $R_B$ ,  $C_{FLT}$  are optional;  $R_1$  and  $C_1$  are the default values)

For example, using  $R_S = 3$  k $\Omega$ , the slope is lowered to 75 mV per decade or 3.75 mV/dB. Table I provides a selection of suitable values for  $R_S$  and the resulting slopes.

Table I. Examples of Lowering the Slope

$R_S$ (k $\Omega$ )	$V_Y$ (mV/dec)
3	75
5	100
15	150

In addition to uses in filter and comparator functions, the buffer amplifier provides the means to adjust both the slope and intercept, which require a minimal number of external components. The high input impedance at BFIN, low input offset voltage, large output swing, and wide bandwidth of this amplifier permit numerous transformations of the basic  $V_{LOG}$  signal, using standard op amp circuit practices. For example, it has been noted that to raise the gain of the buffer, and therefore the slope, a feedback attenuator,  $R_A$  and  $R_B$  in Figure 3, should be inserted between VLOG and the inverting input Pin BFNG.

A wide range of gains may be used and the resistor magnitudes are not critical; their parallel sum should be about equal to the net source resistance at the noninverting input. When high gains are used, the output dynamic range will be reduced; for maximum swing of 4.8 V, it will amount to simply 4.8 V/ $V_Y$  decades. Thus, using a ratio of 3 $\times$ , to set up a slope 30 mV/dB (600 mV/decade), eight decades can be handled, while with a ratio of 5 $\times$ , which sets up a slope of 50 mV/dB (1 V/decade), the dynamic range is 4.8 decades, or 96 dB. When using a lower positive supply voltage, the calculation proceeds in the same way, remembering to first subtract 0.2 V to allow for 0.1 V upper and lower headroom in the output swing.

Alteration of the logarithmic intercept is only slightly more tricky. First note that it will rarely be necessary to lower the intercept below a value of 100 pA, since this merely raises all output voltages further above ground. However, where this is required, the first step is to raise the voltage  $V_{LOG}$  by connecting a resistor,  $R_Z$ , from VLOG to VREF (2 V) as shown in Figure 4.

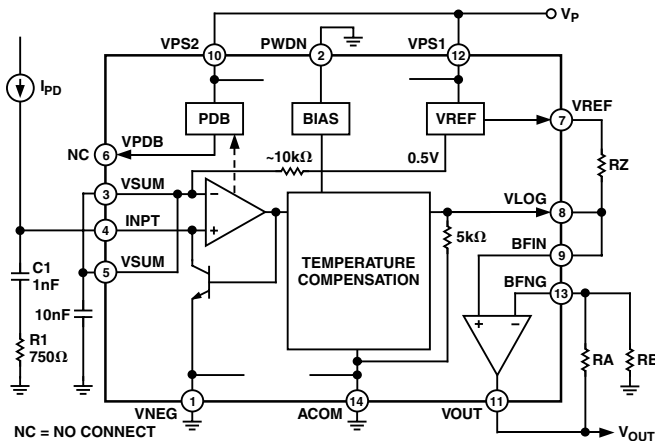

Figure 4. Method for Lowering the Intercept

This has the effect of elevating  $V_{LOG}$  for small inputs while lowering the slope to some extent because of the shunt effect of  $R_Z$  on the 5 k $\Omega$  output resistance. Then, if necessary, the slope may be increased as before, using a feedback attenuator around the buffer. Table II lists some examples of lowering the intercept combined with various slope variations.

Table II. Examples of Lowering the Intercept

$V_Y$ (mV/decade)	$I_Z$ (pA)	$R_A$ (k $\Omega$ )	$R_B$ (k $\Omega$ )	$R_Z$ (k $\Omega$ )
200	1	20.0	100	25
200	10	10.0	100	50
200	50	3.01	100	165
300	1	10.0	12.4	25
300	10	8.06	12.4	50
300	50	6.65	12.4	165
400	1	11.5	8.2	25
400	10	9.76	8.2	50
400	50	8.66	8.2	165
500	1	16.5	8.2	25
500	10	14.3	8.2	50
500	50	13.0	8.2	165

Equations for use with Table II:

$$V_{OUT} = G \left[ V_Y \times \frac{R_Z}{R_Z + R_{LOG}} \times \log_{10} \left( \frac{I_{PD}}{I_Z} \right) + V_{REF} \times \frac{R_{LOG}}{R_{LOG} + R_Z} \right]$$

where

$$G = 1 + \frac{R_A}{R_B} \text{ and } R_{LOG} = 5 \text{ k}\Omega$$

Generally, it will be useful to raise the intercept. Keep in mind that this moves the  $V_{LOG}$  line in Figure 2 to the right, lowering all output values. Figure 5 shows how this is achieved. The feedback resistors,  $R_A$  and  $R_B$ , around the buffer are now augmented with a third resistor,  $R_Z$ , placed between the Pins BFNG and VREF. This raises the zero-signal voltage on BFNG, which has the effect of pushing  $V_{OUT}$  lower. Note that the addition of this resistor also alters the feedback ratio. However, this is readily compensated in the design of the network. Table III lists the resistor values for representative intercepts.

Table III. Examples of Raising the Intercept

$V_Y$ (mV/decade)	$I_Z$ (nA)	$R_A$ (k $\Omega$ )	$R_B$ (k $\Omega$ )	$R_C$ (k $\Omega$ )
300	10	7.5	37.4	24.9
300	100	8.25	130	18.2
400	10	10	16.5	25.5
400	100	9.76	25.5	16.2
400	500	9.76	36.5	13.3
500	10	12.4	12.4	24.9
500	100	12.4	16.5	16.5
500	500	11.5	20.0	12.4

Equations for use with Table III:

$$V_{OUT} = G \left[ V_Y \times \log_{10} \left( \frac{I_{PD}}{I_Z} \right) - V_{REF} \times \frac{R_A \parallel R_B}{R_A \parallel R_B + R_C} \right]$$

where

$$G = 1 + \frac{R_A}{R_B \parallel R_C} \text{ and } R_A \parallel R_B = \frac{R_A \times R_B}{R_A + R_B}$$

# AD8304

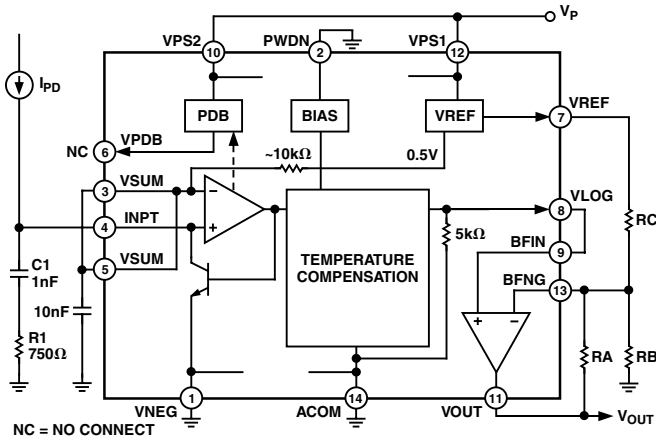

Figure 5. Method for Raising the Intercept

## Low Supply Slope and Intercept Adjustment

When using the device with a positive supply less than 4 V, it is necessary to reduce the slope and intercept at the VLOG Pin in order to preserve good log conformance over the entire 160 dB operating range. The voltage at the VLOG Pin is generated by an internal current source with an output current of 40  $\mu\text{A}/\text{decade}$  feeding the internal laser-trimmed output resistance of 5 k $\Omega$ . When the voltage at the VLOG Pin exceeds  $V_p - 2.3$  V, the current source ceases to respond linearly to logarithmic increases in current. This headroom issue can be avoided by reducing the logarithmic slope and intercept at the VLOG Pin. This is accomplished by connecting an external resistor  $R_S$  from the VLOG Pin to ground in combination with an intercept lowering resistor  $R_Z$ . The values shown in Figure 6 illustrate a good solution for a 3.0 V positive supply. The resulting logarithmic slope measured at VLOG is 62.5 mV/decade with a new intercept of 57 fA. The original logarithmic slope of 200 mV/decade can be recovered using voltage gain on the internal buffer amplifier.

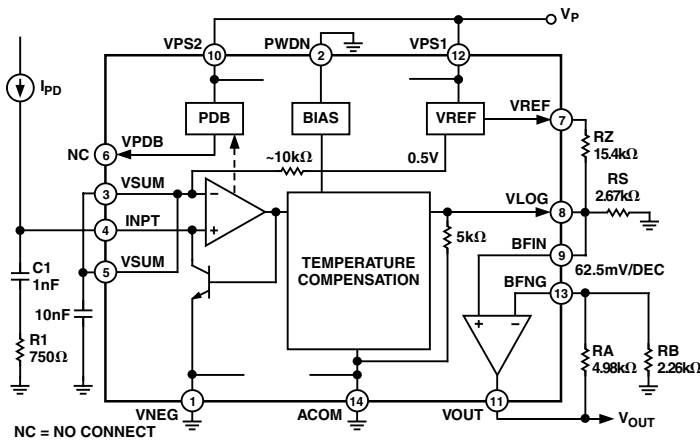

Figure 6. Recommended Low Supply Application Circuit

## Using the Adaptive Bias

For most photodiode applications, the placement of the anode somewhat above ground is acceptable, as long as the positive bias on the cathode is adequate to support the peak current for a particular diode, limited mainly by its series resistance. To address this matter, the AD8304 provides for the diode a bias that varies linearly with the current. This voltage appears at Pin VPDB, and varies from 0.6 V (reverse-biasing the diode by 0.1 V) for  $I_{PD} = 100$  pA and rises to 2.6 V (for a diode bias of 1 V) at  $I_{PD} = 10$  mA. This results in a constant internal junction bias of 0.1 V when the series resistance of the photodiode is 200  $\Omega$ . For optical power measurements over a wide dynamic range the adaptive biasing function will be valuable in minimizing dark current while preventing the loss of photodiode bias at high currents. Use of the adaptive bias feature is shown in Figure 7.

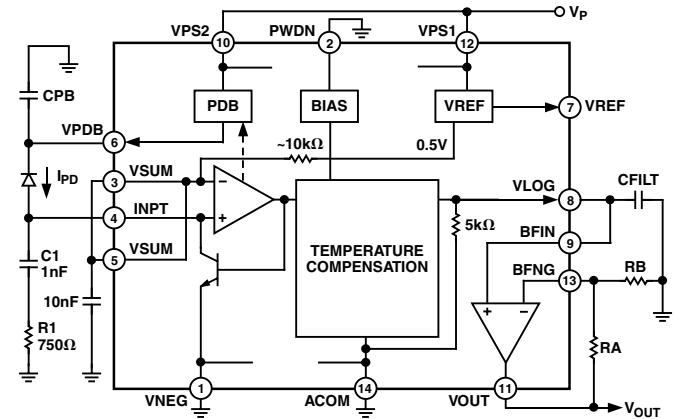

Figure 7. Using the Adaptive Biasing

Capacitor CPB, between the photodiode cathode at Pin VPDB and ground, is included to lower the impedance at this node and thereby improve the high frequency accuracy at those current levels where the AD8304 bandwidth is high. It also ensures an HF path for any high frequency modulation on the optical signal which might not otherwise be accurately averaged. It will not be necessary in all cases, and experimentation may be required to find an optimum value.

## Changing the Voltage at the Summing Node

The default value of VSUM is determined by using a quarter of VREF (2 V). This may be altered by applying an independent voltage source to VSUM, or by adding an external resistive divider from VREF to VSUM. This network will operate in parallel with the internal divider (40 k $\Omega$  and 13.3 k $\Omega$ ), and the choice of external resistors should take this into account. In practice, the total resistance of the added string may be as low as 10 k $\Omega$  (consuming 400  $\mu\text{A}$  from VREF). Low values of VSUM and thus  $V_{CE}$  (see Figure 13) are not advised when large values of  $I_{PD}$  are expected.

## Implementing Low-Pass Filters

Noise, leading to uncertainty in an observed value, is inherent to all measurement systems. Translinear log amps exhibit significant amounts of noise for reasons stated above, and are more troublesome at low current levels. The standard way of addressing this problem is to average the measurement over an appropriate time interval. This can be achieved in the digital domain, in post-ADC DSP, or in analog form using a variety of low-pass structures.

The use of a capacitor at the VLOG Pin to create a single-pole filter has already been mentioned. The small added cost of the few external components needed to realize a multipole filter is often justified in a high performance measurement system. Figure 8 shows a Sallen-Key filter structure. Here, the resistor needed at the front of the network is provided entirely by the accurate 5 kΩ present at the VLOG output; R<sub>B</sub> will have a similar value. The corner frequency and Q (damping factor) are determined by the capacitors C<sub>A</sub> and C<sub>B</sub> and the gain G = (R<sub>A</sub> + R<sub>B</sub>)/R<sub>B</sub>. A suggested starting point for choosing these components using various gains is provided in Table IV; the values shown are for a 1 kHz corner (also see TPC 12). This frequency can be increased or decreased by scaling the capacitor values. Note that R<sub>D</sub>, G, and the capacitor ratio C<sub>A</sub>/C<sub>B</sub> should not deviate from the suggested values to maintain the shape of the ac amplitude response and pulse overshoot provided by the values shown in this table. In all cases, the roll-off rate above the corner is 40 dB/dec.

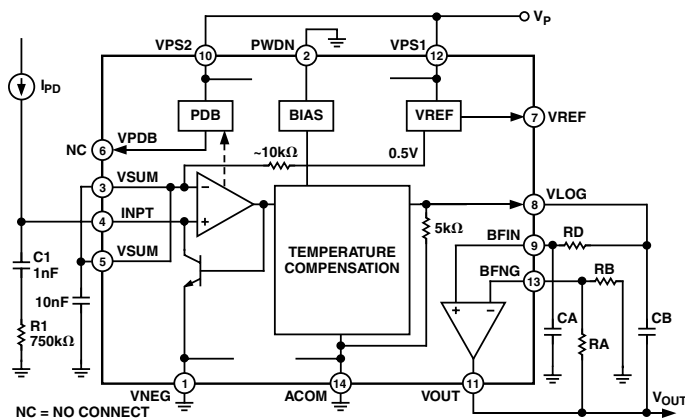

Figure 8. Two-Pole Low-Pass Filter

Table IV. Two-Pole Filter Parameters for 1 kHz Cutoff Frequency\*

R <sub>A</sub> (kΩ)	R <sub>B</sub> (kΩ)	G	V <sub>Y</sub> (V/decade)	R <sub>D</sub> (kΩ)	C <sub>A</sub> (nF)	C <sub>B</sub> (nF)
0	open	1	0.2	11.3	12	12
10	10	2	0.4	6.02	33	22
12	8	2.5	0.5	12.1	33	18
24	6	5	1.0	10.0	33	18

The corner frequency can be adjusted by scaling capacitors C<sub>A</sub> and C<sub>B</sub>. For example, to reduce the corner frequency to 100 Hz, raise the values of C<sub>A</sub> and C<sub>B</sub> by 10 ×.  
\*See TPC 12.

**Operation in Comparator Modes**

In certain applications, the need may arise to generate a logical output when the input current has reached a certain value. This can be easily addressed by using a fraction of the voltage reference to provide the setpoint (threshold) and using the buffer without feedback in a comparator mode, as illustrated in Figure 9. Since V<sub>LOG</sub> runs from ground up to 1.6 V maximum, the 2 V reference is more than adequate to cover the full dynamic range of I<sub>PD</sub>. Note that the threshold for an increasing I<sub>PD</sub> is unchanged, while the release point for decreasing currents is 5 dB below this. Raising R<sub>H</sub> to 5 MΩ reduces the hysteresis to 0.5 dB, or it may be increased using a lower value for R<sub>H</sub>.

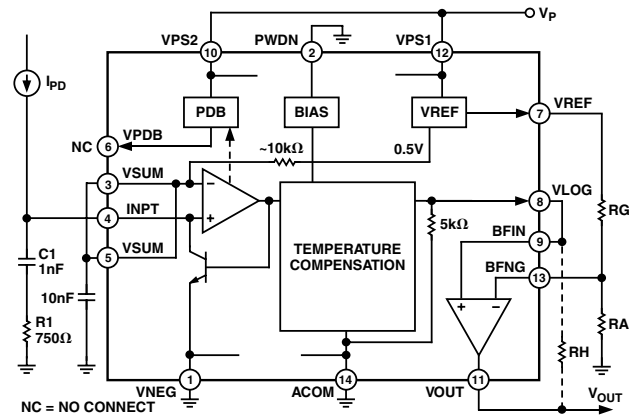

Figure 9. Using the Buffer as a Comparator

**Using a Negative Supply**

Most applications of the AD8304 will require only a single supply of 3.0 V to 5.5 V. However, to provide further versatility, dual supplies may be employed, as illustrated in Figure 10.

The use of a negative supply, V<sub>N</sub>, allows the summing node to be placed exactly at ground level, because the input transistor (Q1 in Figure 1) will have a negative bias on its emitter. V<sub>N</sub> may be as small as -0.5 V, making the V<sub>CE</sub> the same as for the default case. This bias need not be accurate, and a poorly defined source can be used.

A larger supply of up to -5 V may be used. The effect on scaling is minor. It merely moves the intercept by ~0.01 dB/V. Accordingly, an uncertainty of 0.2 V in V<sub>N</sub> would result in a negligible error of 0.002 dB. The slope is unaffected by V<sub>N</sub>. The log linearity will be degraded at the extremes of the dynamic range as indicated in Figure 11. The bias current, buffer output (and its load) current, and the full I<sub>PD</sub> all have to be absorbed by this negative supply, and its supply capacity must be ensured for the maximum current condition.

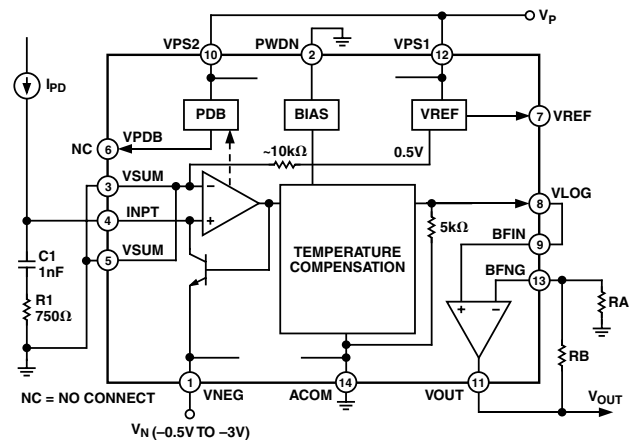

Figure 10. Using a Negative Supply

With the summing node at ground, the AD8304 may now be used as a voltage-input log amp, simply by inserting a suitably scaled resistor from the voltage source to the INPT Pin. The logarithmic accuracy for small voltages is limited by the offset of the JFET op amp, appearing between this pin and VSUM.

The use of a negative supply also allows the output to swing below ground, thereby allowing the intercept to correspond to a midrange value of I<sub>PD</sub>. However, the voltage V<sub>LOG</sub> remains referenced to the

# AD8304

ACOM Pin, and does not normally go negative with regard to this pin, but is free to do so. Therefore, a resistor from VLOG to the negative supply can lower  $V_{LOG}$ , thus raising the intercept. A more accurate method for repositioning the intercept is described below.

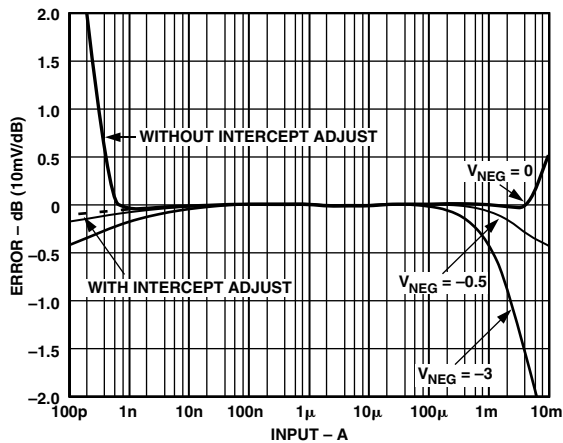

Figure 11. Log Conformance (Linearity) vs.  $I_{PD}$  for Various Negative Supplies

## APPLICATIONS

The AD8304 incorporates features that improve its usefulness in both fiber optic supervisory applications and in more general ones. To aid in the exploration of these possibilities, a SPICE macromodel is provided and a versatile evaluation board is available.

The macromodel is shown in generalized schematic form (and thus is independent of variations in SPICE programs) in Figure 12. Q1, QM, and Q2 (here made equal in size) correspond to the identical transistors in Figure 1. The model parameters for these transistors are not critical; the default model provided in SPICE libraries will be satisfactory. However, the AD8304 employs compensation techniques to reduce errors caused by junction resistances (notably, RB and RE) at high input currents. Therefore, it is advisable to set these to zero. While this will not model the AD8304 precisely, it is safer than using possibly high default values for these parameters. The low current model parameters may also need consideration. Note that no attempt is made to capture either dynamic behavior or the effects of temperature in this simple macromodel; scaling is correct for 27°C.

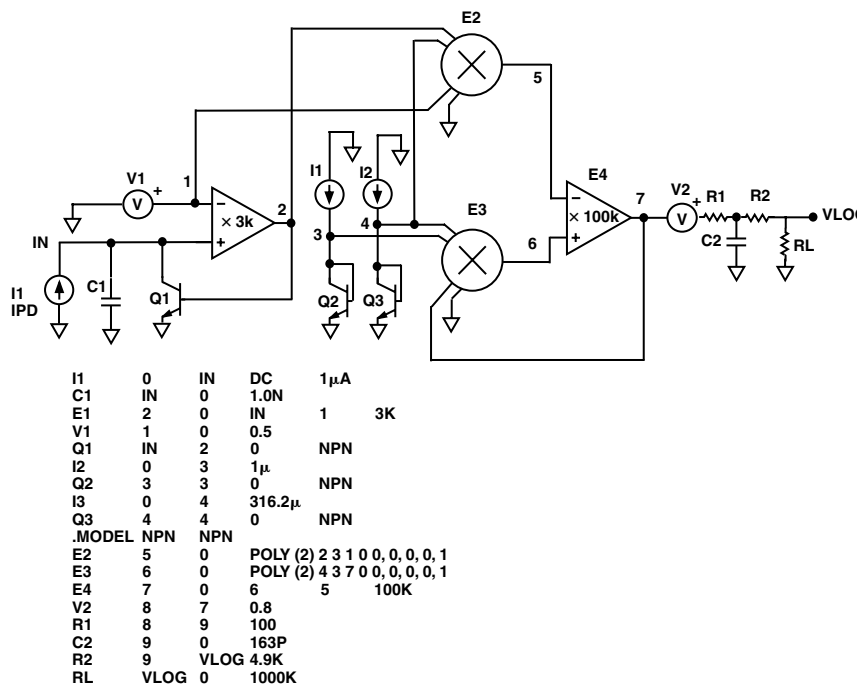

Figure 12. Basic Macromodel



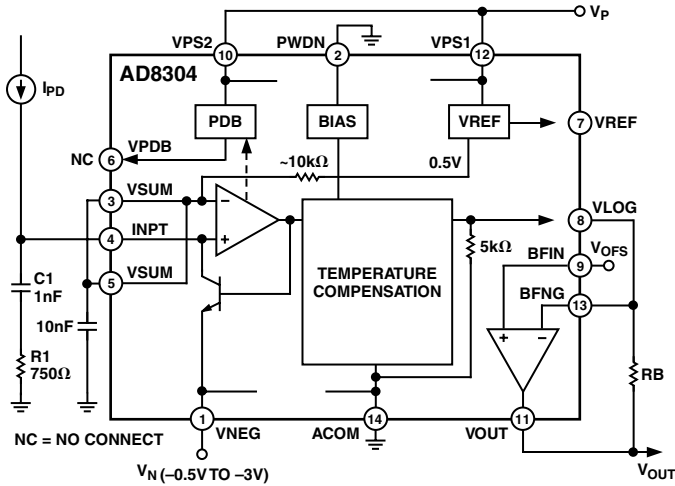

Figure 15. Using the Buffer to Invert the Polarity of the Slope

When the gain is set to 13 ( $R_B = 5\text{ k}\Omega$ ) the  $2\text{ V } V_{REF}$  can be tied directly to  $BFIN$ , in which case the starting point for the output response is at  $4\text{ V}$ . However, since the slope in this case is only  $-0.2\text{ V/decade}$ , the full current range will only take the output

down by  $1.6\text{ V}$ . Clearly, a higher slope (or gain) is desirable, in which case  $V_{OFS}$  should be set to a smaller voltage to avoid railing the output at low currents. If  $V_{OFS} = 1.2\text{ V}$  and  $G = 33$ ,  $V_{OUT}$  now starts at  $4.8\text{ V}$  and falls through this same voltage toward ground with a slope of  $-0.6\text{ V per decade}$ , spanning the full range of  $I_{PD}$ .

### Programmable Level Comparator with Hysteresis

The buffer amplifier and reference voltage permit a calibrated level detector to be realized. Figure 16 shows the use of a 10-bit MDAC to control the setpoint to within  $0.1\text{ dB}$  of an exact value over the  $100\text{ dB}$  range of  $1\text{ nA} \leq I_{PD} \leq 100\text{ }\mu\text{A}$  when the full-scale output of the MDAC is equal to that of its reference. The  $2\text{ V } V_{REF}$  also sets the minimum value of  $V_{SPT}$  to  $0.2\text{ V}$ , corresponding to an input of  $1\text{ nA}$ . Since  $100\text{ dB}$  at the  $V_{LOG}$  interface corresponds to a  $1\text{ V}$  span, the resistor network is calculated to provide a maximum  $V_{SPT}$  of  $1.2\text{ V}$  while adding the required  $10\%$  of  $V_{REF}$ .

In this example, the hysteresis range is arranged to be  $0.1\text{ dB}$ , ( $1\text{ mV}$  at  $V_{LOG}$ ) when using a  $5\text{ V}$  supply. This will usually be adequate to prevent noise that causes the comparator output to thrash. That risk can be reduced further by using a low-pass filtering capacitor at  $V_{LOG}$  (shown dotted) to decrease the noise bandwidth.

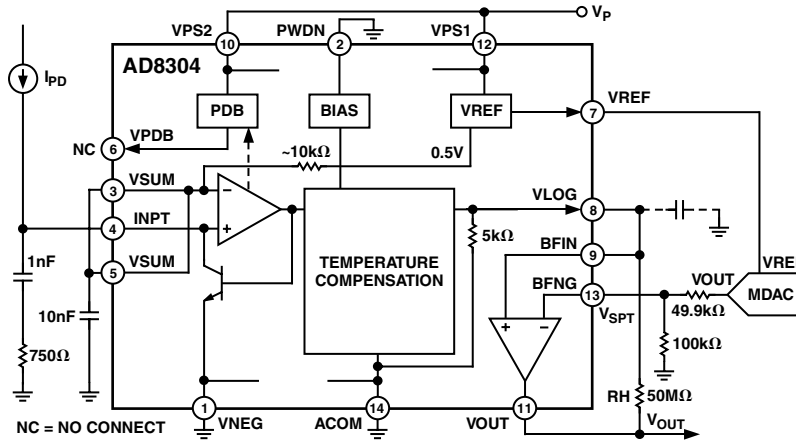

Figure 16. Calibrated Level Comparator

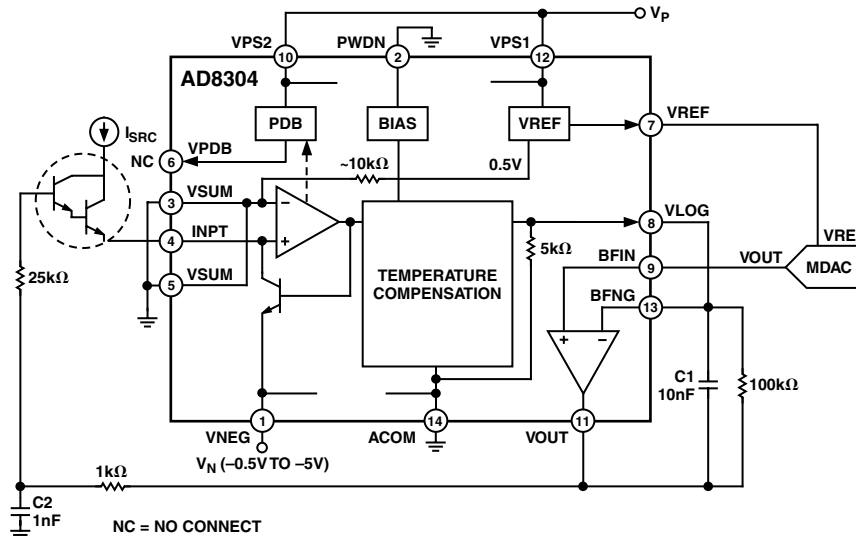

Figure 17. Multidecade Current Source

## Programmable Multidecade Current Source

The AD8304 supports a wide variety of general (nonoptical) applications. For example, the need frequently arises in test equipment to provide an accurate current that can be varied over many decades. This can be achieved using a logarithmic amplifier as the measuring device in an inverse function loop, as illustrated in Figure 16. This circuit generates the current:

$$I_{SRC} = 100 \text{ pA} \times 10^{(V_{SPT}/0.2)} \quad (17)$$

The principle is as follows. The current in QA is forced to supply a certain  $I_{PD}$  by measuring the error between a setpoint  $V_{SPT}$  and  $V_{LOG}$ , and nulling this error by integration. This is performed by the internal op amp and capacitor C1, with a time constant formed with the internal 5 k $\Omega$  resistor. The choice of C1 in this example ensures loop stability over the full eight-decade range of output currents; C2 reduces phase lag. The system is completed with a 10-bit MDAC using  $V_{REF}$  as its reference, whose output is scaled to 1.6 V FS by R1 and R2 (whose parallel sum is also 5 k $\Omega$ ).

Transistor QA may be a single bipolar device, which will result in a small alpha error in  $I_{SRC}$  (the current is monitored in the emitter branch), or a Darlington pair or an MOS device, either of which ensure a negligible difference between  $I_{PD}$  and  $I_{SRC}$ . In this example, the bipolar pair is used. The output voltage compliance is determined by the collector breakdown voltage of these transistors, while the minimum voltage depends on where  $V_{SUM}$  is placed. Optional components could be added to put this node and  $V_{NEG}$  at a low enough bias to allow the voltage to go slightly below ground.

Many variations of this basic circuit are possible. For example, the current can be continuously controlled by a simple voltage, or by a second current. Larger output currents can be controlled by setting  $V_{SUM}$  to zero and using a current shunt divider.

## Characterization Setups and Methods

During the primary characterization of the AD8304, the device was treated as a high precision current-in logarithmic amplifier (converter). Rather than attempting to accurately generate photocurrents by illuminating a photodiode, precision current sources, like the Keithley 236, were used as input sources. Great care was taken when applying the low level input currents. The triax output of the current source was used with the guard connected to  $V_{SUM}$  at the characterization board. On the board the input trace was guarded by connecting adjacent traces and a portion of an internal copper layer to the  $V_{SUM}$  Pins. One obvious reason for the care was leakage current. With 0.5 V as the nominal bias on the  $INPT$  Pin, a resistance of 50 G $\Omega$  to ground would cause 10 pA of leakage, or about one decibel of error at the low end of the measurement range. Additionally, the high output resistance of the current source and the long signal cable lengths commonly needed in characterization make a good receiver for 60 Hz emissions. Good guarding techniques help to reduce the pickup of unwanted signals.

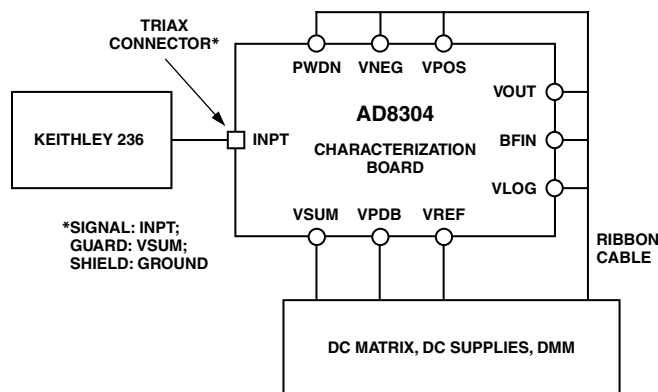

Figure 18. Primary Characterization Setup

The primary characterization setup shown in Figure 18 is used to measure the static performance, logarithmic conformance, slope and intercept, buffer offset and  $V_{REF}$  drift with temperature, and the performance of the  $VPDB$  Pin functions. For the dynamic tests, such as noise and bandwidth, more specialized setups are used.

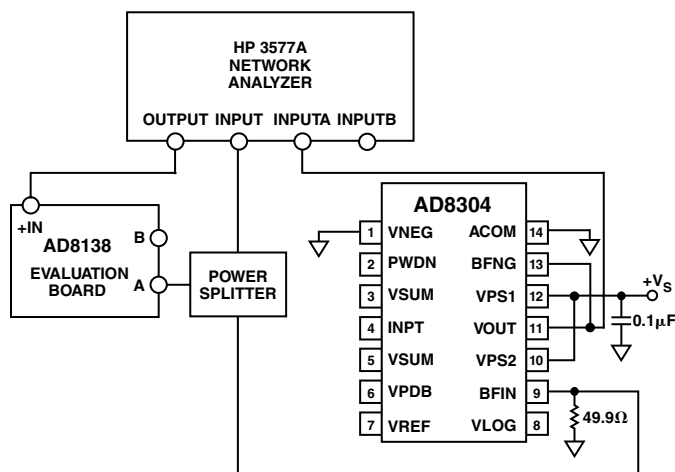

Figure 19. Configuration for Buffer Amplifier Bandwidth Measurement

Figure 19 shows the configuration used to measure the buffer amplifier bandwidth. The AD8138 Evaluation Board provides a dc offset at the buffer input, allowing measurement in single-supply mode. The network analyzer input impedance was set to 1 M $\Omega$ .

# AD8304

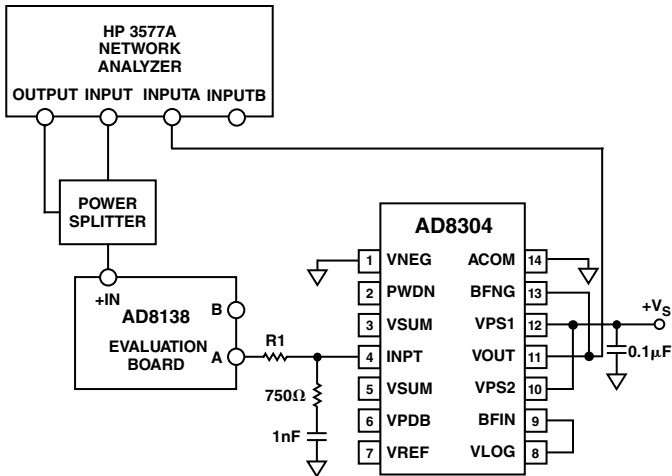

Figure 20. Configuration for Logarithmic Amplifier Bandwidth Measurement

The setup shown in Figure 20 was used for frequency response measurements of the logarithmic amplifier section. In this configuration, the AD8138 output was offset to 1.5 V and R1 was adjusted to provide the appropriate operating current. The buffer amplifier was then used; still any capacitance added at the VLOG Pin during measurement would form a filter with the on-chip 5 kΩ resistor.

The configuration illustrated in Figure 21 measures the device noise. Batteries provide both the supply and the input signal to remove the supplies as a possible noise source and to reduce ground loop effects. The AD8304 Evaluation Board and the current setting resistors are mounted in closed aluminum enclosures to provide additional shielding to external noise sources.

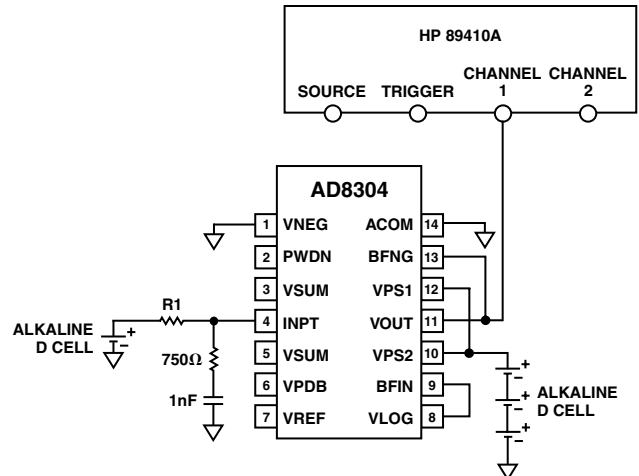

Figure 21. Configuration for Noise Spectral Density Measurement

## Evaluation Board

An evaluation board is available for the AD8304, the schematic for which is shown in Figure 23 and the two board sides are shown in Figure 23 and Figure 24. It can be configured for a wide variety of experiments. The board is factory set for Photoconductive Mode with a buffer gain of unity, providing a slope of 10 mV/dB and an intercept of 100 pA. By substituting resistor and capacitor values, all of the application circuits presented in this data sheet can be evaluated. Table V describes the various configuration options.

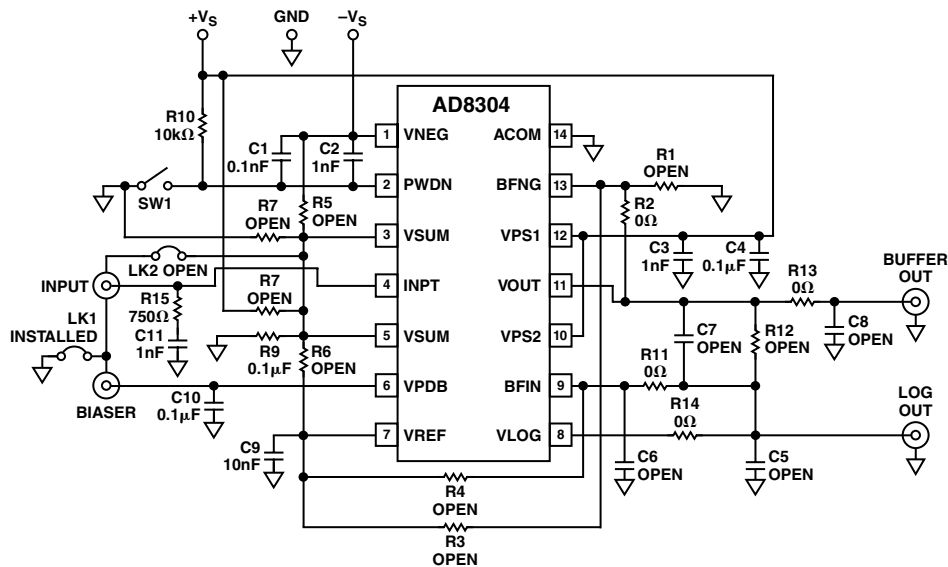

Figure 22. Evaluation Board Schematic

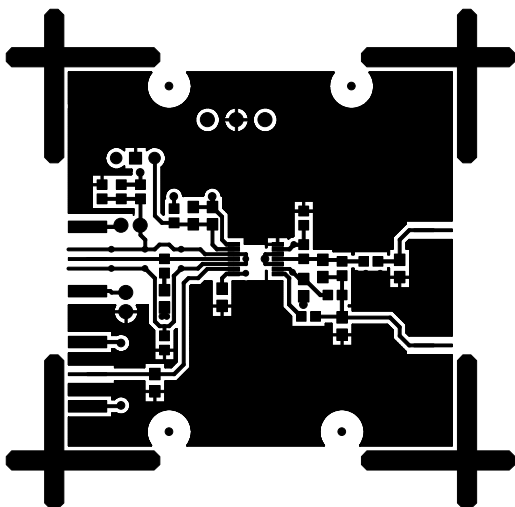

Figure 23. Component Side Layout

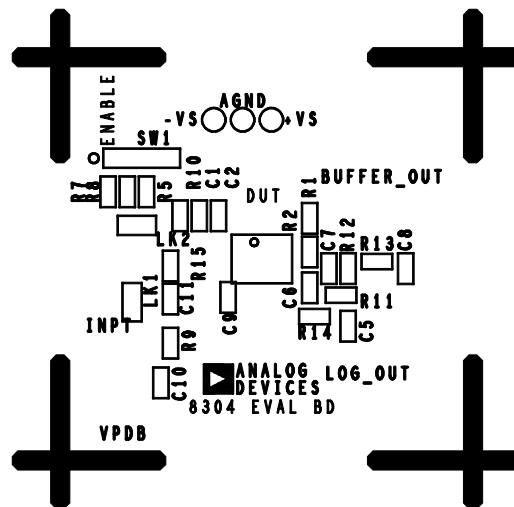

Figure 24. Component Side Silkscreen

Table V. Evaluation Board Configuration Options

Component	Function	Default Condition
V <sub>P</sub> , V <sub>N</sub> , AGND	Positive and Negative Supply and Ground Pins	Not Applicable
SW1, R10	Device Enable: When SW1 is in the “0” position, the PWDN Pin is connected to ground and the AD8304 is in its normal operating mode.	SW1 = Installed R10 = 10 k $\Omega$ (Size 0603)
R1, R2	Buffer Amplifier Gain/Slope Adjustment: The logarithmic slope of the AD8304 can be altered using the buffer’s gain-setting resistors, R1 and R2.	R1 = Open (Size 0603) R2 = 0 $\Omega$ (Size 0603)
R3, R4	Intercept Adjustment: A dc offset can be applied to the input terminals of the buffer amplifier to adjust the effective logarithmic intercept.	R3 = Open (Size 0603) R4 = Open (Size 0603)
R5, R6, R7, R8, R9	Bias Adjustment: The voltage on the VSUM and INPT Pins can be altered using appropriate resistor values. R9 is populated with a decoupling capacitor to reduce noise pickup. The decoupling capacitor can be removed when a fixed bias is applied to VSUM.	R5 = R6 = Open (Size 0603) R7 = R8 = Open (Size 0603) R9 = 0.1 $\mu$ F (Size 0603)
C1, C2, C3, C4, C9	Supply Decoupling Capacitors	C1 = C4 = 0.1 $\mu$ F (Size 0603) C2 = C3 = 1 nF (Size 0603) C9 = 10 nF (Size 0603)
C10	Photodiode Biased Decoupling: Provides high frequency decoupling of the adaptive bias output at Pin VPDB.	C10 = 0.1 $\mu$ F (Size 0603)
C5, C6, C7, C8, R11, R12, R13, R14	Output Filtering: Allows implementation of a variety of filter configurations, from simple RC low-pass filters to three-pole Sallen and Key.	R11 = R13 = 0 $\Omega$ (Size 0603) R12 = Open (Size 0603) R14 = 0 $\Omega$ (Size 0603) C5 = C6 = Open (Size 0603) C7 = C8 = Open (Size 0603)
R15, C11	Input Filtering: Provides essential HF compensation at the input Pin INPT.	R15 = 750 $\Omega$ (Size 0603) C11 = 1 nF (Size 0603)
LK1, LK2	Guard/Shield Options: The shells of the SMA connectors used for the input and the photodiode bias can be set to the voltage on the VSUM Pin or connected to ground.	LK1 = Installed LK2 = Open

**OUTLINE DIMENSIONS**  
**14-Lead Thin Shrink Small Outline Package [TSSOP]**  
**(RU-14)**

Dimensions shown in millimeters

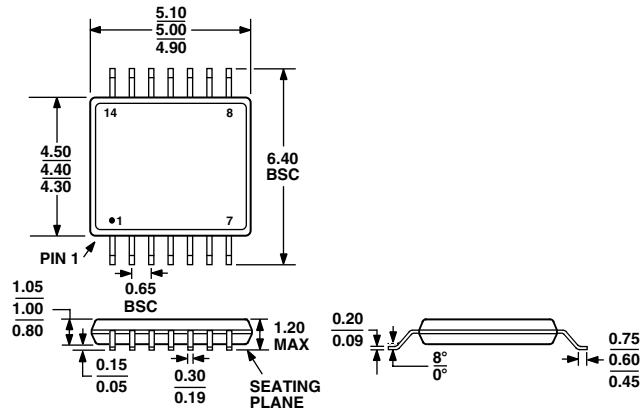

COMPLIANT TO JEDEC STANDARDS MO-153AB-1

## Revision History

Location	Page
<b>8/02—Data Sheet changed from REV. 0 to REV. A.</b>	
Edits to SPECIFICATIONS .....	2
New TPC 1 .....	4
Edits to TPC 7 caption .....	5
Changes to TPC 19 .....	7
Edits to USING THE AD8304 section .....	10
Changes to Figure 3 .....	10
Edits to Table I .....	10
Edits to Table III .....	11
New Figure 12 .....	14
Changes to Figure 22 .....	18
Changes to Table V .....	19