

### FEATURES

Half-duplex isolated RS-485 transceiver  
**PROFIBUS compliant**  
 Complies with ANSI TIA/EIA RS-485-A-1998 and ISO 8482:1987(E)  
**20 Mbps data rate**  
**Low power operation: 12 mA ( $I_{DD1} + I_{DD2}$ ) @ 20 Mbps**  
**5 V or 3 V operation ( $V_{DD1}$ )**  
**High common-mode transient immunity: >25 kV/ $\mu$ s**  
**Isolated DE status output**  
**Receiver open-circuit fail-safe design**  
**Thermal shutdown protection**  
**Safety and regulatory approvals:**  
 UL recognition—2500  $V_{RMS}$  for 1 minute per UL 1577  
 CSA component acceptance notice #5A  
 VDE certificate of conformity  
 DIN EN 60747-5-2 (VDE 0884 Part 2):2003-01  
 DIN EN 60950 (VDE 0805):2001-12; EN 60950:2000  
 $V_{IORM} = 560$  V peak  
**Operating temperature range:  $-40^{\circ}$  to  $85^{\circ}$ C**  
**Wide-body, 16-lead SOIC package**

### APPLICATIONS

Isolated RS-485/RS-422 interfaces  
 PROFIBUS networks  
 Industrial field networks  
 Multipoint data transmission systems

### GENERAL DESCRIPTION

The ADM2486 differential bus transceiver is an integrated, galvanically isolated component designed for bidirectional data communication on multipoint bus transmission lines. It is designed for balanced transmission lines and complies with ANSI TIA/EIA RS-485-A-1998 and ISO 8482:1987(E).

The device employs Analog Devices' iCoupler technology to combine a 3-channel isolator, a 3-state differential line driver, and a differential input receiver into a single package. The logic side of the device can be powered with either a 5 V or a 3 V supply while the bus side is powered with an isolated 5 V supply.

The ADM2486 driver has an active high enable. The driver differential outputs and the receiver differential inputs are connected internally to form a differential input/output port that imposes minimal loading on the bus when the driver is disabled or when  $V_{DD1}$  or  $V_{DD2} = 0$  V. Also provided is an active high receiver disable that causes the receive output to enter a high impedance state.

The device has current-limiting and thermal shutdown features to protect against output short circuits and situations where bus contention might cause excessive power dissipation. The part is fully specified over the industrial temperature range and is available in a 16-lead, wide-body SOIC package.

### FUNCTIONAL BLOCK DIAGRAM

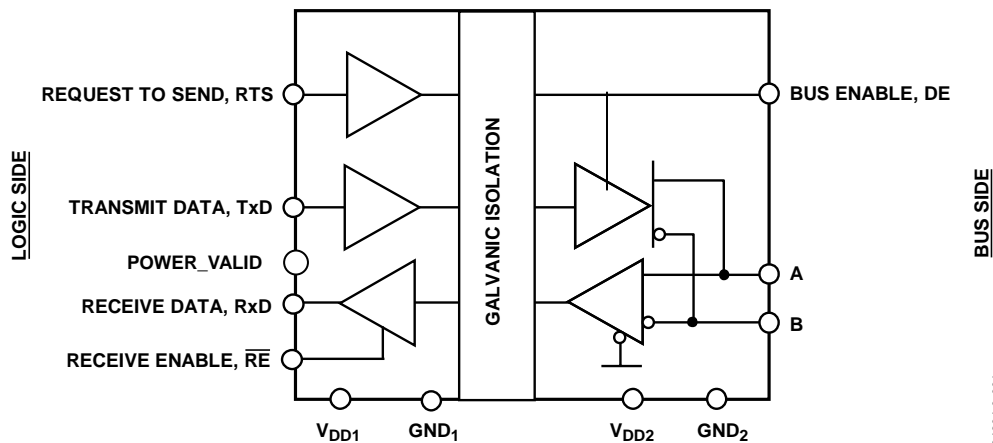

Figure 1.

### Rev. 0

Information furnished by Analog Devices is believed to be accurate and reliable. However, no responsibility is assumed by Analog Devices for its use, nor for any infringements of patents or other rights of third parties that may result from its use. Specifications subject to change without notice. No license is granted by implication or otherwise under any patent or patent rights of Analog Devices. Trademarks and registered trademarks are the property of their respective owners.

## TABLE OF CONTENTS

Specifications.....	3	Circuit Description.....	13
Timing Specifications.....	5	Electrical Isolation.....	13
Absolute Maximum Ratings.....	6	Truth Tables.....	13
ESD Caution.....	6	Power-Up/Power-Down Thresholds .....	13
ADM2486 Characteristics .....	7	Thermal Shutdown .....	14
Package Characteristics .....	7	Receiver Fail-Safe Inputs .....	14
Regulatory Information.....	7	Magnetic Field Immunity.....	14
Insulation and Safety-Related Specifications.....	7	Applications Information .....	15
VDE 0884 Insulation Characteristics .....	8	Power Valid Input .....	15
Pin Configuration and Function Descriptions.....	9	Isolated Power-Supply Circuit.....	15
Test Circuits.....	10	Outline Dimensions .....	16
Switching Characteristics .....	11	Ordering Guide .....	16
Typical Performance Characteristics .....	12		

## REVISION HISTORY

7/04—Revision 0: Initial Version

## SPECIFICATIONS

$2.7 \leq V_{DD1} \leq 5.5 \text{ V}$ ,  $4.75 \text{ V} \leq V_{DD2} \leq 5.25 \text{ V}$ ,  $T_A = T_{MIN}$  to  $T_{MAX}$ , unless otherwise noted.

Table 1.

Parameter	Min	Typ	Max	Unit	Test Conditions/Comments
<b>DRIVER</b>					
Differential Outputs					
Differential Output Voltage, $V_{OD}$			5	V	$R = \infty$ , Figure 3
	2.1		5	V	$R = 50 \Omega$ (RS-422), Figure 3
	2.1		5	V	$R = 27 \Omega$ (RS-485), Figure 3
	2.1		5	V	$V_{TST} = -7 \text{ V}$ to $12 \text{ V}$ , $V_{DD1} \geq 4.75$ , Figure 4
$\Delta  V_{OD} $ for Complementary Output States			0.2	V	$R = 27 \Omega$ or $50 \Omega$ , Figure 3
Common-Mode Output Voltage, $V_{OC}$			3	V	$R = 27 \Omega$ or $50 \Omega$ , Figure 3
$\Delta  V_{OC} $ for Complementary Output States			0.2	V	$R = 27 \Omega$ or $50 \Omega$ , Figure 3
Output Short-Circuit Current, $V_{OUT} = \text{High}$	60		200	mA	$-7 \text{ V} \leq V_{OUT} \leq +12 \text{ V}$
Output Short-Circuit Current, $V_{OUT} = \text{Low}$	60		200	mA	$-7 \text{ V} \leq V_{OUT} \leq +12 \text{ V}$
Bus Enable Output					
Output High Voltage	$V_{DD2}-0.1$			V	$I_{ODE} = 20 \mu\text{A}$
	$V_{DD2}-0.3$	$V_{DD2}-0.1$		V	$I_{ODE} = 1.6 \text{ mA}$
	$V_{DD2}-0.4$	$V_{DD2}-0.2$		V	$I_{ODE} = 4 \text{ mA}$
Output Low Voltage			0.1	V	$I_{ODE} = -20 \mu\text{A}$
		0.1	0.3	V	$I_{ODE} = -1.6 \text{ mA}$
		0.2	0.4	V	$I_{ODE} = -4 \text{ mA}$
Logic Inputs					
Input High Voltage	$0.7 V_{DD1}$			V	TxD, RTS, $\overline{RE}$ , PV
Input Low Voltage			$0.25 V_{DD1}$	V	TxD, RTS, $\overline{RE}$ , PV
CMOS Logic Input Current (TxD, RTS, $\overline{RE}$ , PV)	-10	0.01	10	$\mu\text{A}$	TxD, RTS, $\overline{RE}$ , PV = $V_{DD1}$ or $0 \text{ V}$
<b>RECEIVER</b>					
Differential Inputs					
Differential Input Threshold Voltage, $V_{TH}$	-200		200	mV	$-7 \text{ V} \leq V_{CM} \leq +12 \text{ V}$
Input Hysteresis		70		mV	$-7 \text{ V} \leq V_{CM} \leq +12 \text{ V}$
Input Resistance (A, B)	20	30		$\text{k}\Omega$	$-7 \text{ V} \leq V_{CM} \leq +12 \text{ V}$
Input Current (A, B)			0.6	mA	$V_{IN} = +12 \text{ V}$
			-0.35	mA	$V_{IN} = -7 \text{ V}$
RxD Logic Output:					
Output High Voltage	$V_{DD1}-0.1$			V	$I_{OUT} = 20 \mu\text{A}$ , $V_A - V_B = 0.2 \text{ V}$
	$V_{DD1}-0.4$	$V_{DD1}-0.2$		V	$I_{OUT} = 4 \text{ mA}$ , $V_A - V_B = 0.2 \text{ V}$
Output Low Voltage			0.1	V	$I_{OUT} = -20 \mu\text{A}$ , $V_A - V_B = -0.2 \text{ V}$
		0.2	0.4	V	$I_{OUT} = -4 \text{ mA}$ , $V_A - V_B = -0.2 \text{ V}$
Output Short Circuit Current	7		85	mA	$V_{OUT} = \text{GND}$ or $V_{CC}$
Three-State Output Leakage Current			$\pm 1$	$\mu\text{A}$	$0.4 \text{ V} \leq V_{OUT} \leq 2.4 \text{ V}$

# ADM2486

Parameter	Min	Typ	Max	Unit	Test Conditions/Comments
POWER SUPPLY CURRENT					
Logic Side			1.3	mA	RTS = 0 V, V <sub>DD1</sub> = 5.5 V
		2.9		mA	2 Mbps, V <sub>DD1</sub> = 5.5 V, Figure 5
		10.2		mA	20 Mbps, V <sub>DD1</sub> = 5.5 V, Figure 5
			0.8	mA	RTS = 0 V, V <sub>DD1</sub> = 3 V
			1.1	mA	2 Mbps, V <sub>DD1</sub> = 3 V, Figure 5
Bus Side		4.3		mA	20 Mbps, V <sub>DD1</sub> = 3 V, Figure 5
			3.0	mA	RTS = 0 V
		53.4		mA	2 Mbps, RTS = V <sub>DD1</sub> , Figure 5
		86.7		mA	20 Mbps, RTS = V <sub>DD1</sub> , Figure 5
COMMON-MODE TRANSIENT IMMUNITY <sup>1</sup>	25			kV/μs	V <sub>CM</sub> = 1 kV, Transient Magnitude = 800 V
HIGH FREQUENCY COMMON-MODE NOISE IMMUNITY		100		mV	V <sub>HF</sub> = +5V, -2 V < V <sub>TEST2</sub> < 7 V, 1 < f <sub>TEST</sub> < 50 MHz, Figure 6

<sup>1</sup> CM is the maximum common-mode voltage slew rate that can be sustained while maintaining specification-compliant operation. V<sub>CM</sub> is the common-mode potential difference between the logic and bus sides. The transient magnitude is the range over which the common-mode is slewed. The common-mode voltage slew rates apply to both rising and falling common-mode voltage edges.

## TIMING SPECIFICATIONS

$2.7 \leq V_{DD1} \leq 5.5 \text{ V}$ ,  $4.75 \text{ V} \leq V_{DD2} \leq 5.25 \text{ V}$ ,  $T_A = T_{MIN}$  to  $T_{MAX}$ , unless otherwise noted.

Table 2.

Parameter	Min	Typ	Max	Unit	Test Conditions/Comments
<b>DRIVER</b>					
Maximum Data Rate	20			Mbps	
Propagation Delay $t_{PLH}$ , $t_{PHL}$	25	45	55	ns	$R_{LDIFF} = 54 \Omega$ , $C_{L1} = C_{L2} = 100 \text{ pF}$ , Figure 7
RTS-to-DE Propagation Delay	20	35	55	ns	Figure 8
Pulse-Width Distortion, $t_{PWD}$			5	ns	$R_{LDIFF} = 54 \Omega$ , $C_{L1} = C_{L2} = 100 \text{ pF}$ , Figures 7 and 12
Switching Skew, $t_{SKEW}$		2	5	ns	$R_{LDIFF} = 54 \Omega$ , $C_{L1} = C_{L2} = 100 \text{ pF}$ , Figures 7 and 12
Rise/Fall Time $t_R$ , $t_F$		5	15	ns	$R_{LDIFF} = 54 \Omega$ , $C_{L1} = C_{L2} = 100 \text{ pF}$ , Figures 7 and 12
Enable Time		43	53	ns	Figures 9 and 14
Disable Time		43	55	ns	Figures 9 and 14
Enable Skew, $ t_{AZH}-t_{BZL} $ , $ t_{AZL}-t_{BZH} $		1	3	ns	Figures 9 and 14
Disable Skew, $ t_{AHZ}-t_{BLZ} $ , $ t_{ALZ}-t_{BHZ} $		2	5	ns	Figures 9 and 14
<b>RECEIVER</b>					
Propagation Delay $t_{PLH}$ , $t_{PHL}$	25	45	55	ns	$C_L = 15 \text{ pF}$ , Figures 10 and 13
Differential Skew $t_{SKEW}$			5	ns	$C_L = 15 \text{ pF}$ , Figures 10 and 13
Enable Time		3	13	ns	$R_L = 1 \text{ k}\Omega$ , $C_L = 15 \text{ pF}$ , Figures 11 and 15
Disable Time		3	13	ns	$R_L = 1 \text{ k}\Omega$ , $C_L = 15 \text{ pF}$ , Figures 11 and 15
<b>POWER VALID INPUT</b>					
Enable Time		1	2	$\mu\text{s}$	
Disable Time		3	5	$\mu\text{s}$	

## ABSOLUTE MAXIMUM RATINGS

T<sub>A</sub> = 25°C, unless otherwise noted. All voltages are relative to their respective ground.

**Table 3.**

Parameter	Rating
V <sub>DD1</sub>	-0.5 V to +7 V
V <sub>DD2</sub>	-0.5 V to +6 V
Digital Input Voltage (RTS, $\overline{\text{RE}}$ , TxD)	-0.5 V to V <sub>DD1</sub> + 0.5 V
Digital Output Voltage	
RxD	-0.5 V to V <sub>DD1</sub> + 0.5 V
DE	-0.5 V to V <sub>DD2</sub> + 0.5 V
Driver Output/Receiver Input Voltage	-9 V to +14 V
Operating Temperature Range	-40°C to +85°C
Storage Temperature Range	-55°C to +150°C
Average Output Current per Pin	-35 mA to +35 mA
θ <sub>JA</sub> Thermal Impedance	73°C/W
Lead Temperature	
Soldering (10 sec)	260°C
Vapour Phase (60 sec)	215°C
Infrared (15 sec)	220°C

Stresses above those listed under Absolute Maximum Ratings may cause permanent damage to the device. This is a stress rating only; functional operation of the device at these or any other conditions above those indicated in the operational section of this specification is not implied. Exposure to absolute maximum rating conditions for extended periods may affect device reliability.

## ESD CAUTION

ESD (electrostatic discharge) sensitive device. Electrostatic charges as high as 4000 V readily accumulate on the human body and test equipment and can discharge without detection. Although this product features proprietary ESD protection circuitry, permanent damage may occur on devices subjected to high energy electrostatic discharges. Therefore, proper ESD precautions are recommended to avoid performance degradation or loss of functionality.



## ADM2486 CHARACTERISTICS

### PACKAGE CHARACTERISTICS

Table 4.

Parameter	Symbol	Min	Typ	Max	Unit	Test Conditions
Resistance (Input-Output) <sup>1</sup>	R <sub>I-O</sub>		10 <sup>1,2</sup>		Ω	
Capacitance (Input-Output) <sup>1</sup>	C <sub>I-O</sub>		3		pF	f = 1 MHz
Input Capacitance <sup>2</sup>	C <sub>I</sub>		4		pF	
Input IC Junction-to-Case Thermal Resistance	θ <sub>JCI</sub>		33		°C/W	Thermocouple located at center of package underside
Output IC Junction-to-Case Thermal Resistance	θ <sub>JCO</sub>		28		°C/W	

<sup>1</sup> Device considered a two-terminal device: pins 1, 2, 3, 4, 5, 6, 7, and 8 shorted together and pins 9, 10, 11, 12, 13, 14, 15, and 16 shorted together.

<sup>2</sup> Input capacitance is from any input data pin to ground.

### REGULATORY INFORMATION

The ADM2486 will be approved by the following organizations upon product release:

Table 5.

Organization	Approval Type	Notes
UL	To be recognized under 1577 component recognition program. File E214100	In accordance with UL1577, each ADM2486 is proof tested by applying an insulation test voltage ≥ 3000 V rms for 1 second (current leakage detection limit = 5 μA)
CSA	Approved under CSA Component Acceptance Notice #5A. File 205078.	
VDE	Approved according to: DIN EN 60747-5-2 (VDE 0884 Rev. 2):2002-04 DIN EN 60950 (VDE 0805):2001-12;EN 60950:2000 File 2471900-4880-0001	In accordance with VDE 0884, each ADM2486 is proof tested by applying an insulation test voltage ≥ 1050 V <sub>PEAK</sub> for 1 second (partial discharge detection limit = 5 pC).

### INSULATION AND SAFETY-RELATED SPECIFICATIONS

Table 6.

Parameter	Symbol	Value	Unit	Conditions
Rated Dielectric Insulation Voltage		2500	V <sub>RMS</sub>	1-minute duration.
Minimum External Air Gap (Clearance)	L(I01)	8.4 min.	mm	Measured from input terminals to output terminals, shortest distance through air.
Minimum External Tracking (Creepage)	L(I02)	8.1 min.	mm	Measured from input terminals to output terminals, shortest distance path along body.
Minimum Internal Gap (Internal Clearance)		0.017 min.	mm	Insulation distance through insulation.
Tracking Resistance (Comparative Tracking Index)	CTI	>175	V	DIN IEC 112/VDE 0303 Part 1.
Isolation Group		IIIa		Material Group (DIN VDE 0110, 1/89, Table 1).

# ADM2486

## VDE 0884 INSULATION CHARACTERISTICS

This isolator is suitable for safe electrical isolation only within the safety limit data. Maintenance of the safety data must be ensured by means of protective circuits.

An asterisk (\*) on packages denotes VDE 0884 approval for 560 V peak working voltage.

Table 7.

Description	Symbol	Characteristic	Unit
Installation classification per DIN VDE 0110, for rated mains voltage		I to IV	
≤ 150 V rms		I to III	
≤ 300 V rms		I to II	
≤ 400 V rms		40/85/21	
Climatic classification		2	
Pollution degree (DIN VDE 0110, Table 1)			
Maximum working insulation voltage	$V_{IORM}$	400	$V_{PEAK}$
Input to output test voltage, Method b1 $V_{IORM} \times 1.875 = V_{PR}$ , 100% production test, $t_m = 1$ sec, partial discharge < 5 pC	$V_{PR}$	1050	$V_{PEAK}$
Input to output test voltage, Method a (After environmental tests Subgroup 1) $V_{IORM} \times 1.6 = V_{PR}$ , $t_m = 60$ sec, partial discharge < 5 pC (After input and/or safety test Subgroup 2/3) $V_{IORM} \times 1.2 = V_{PR}$ , $t_m = 60$ sec, partial discharge < 5 pC		896	$V_{PEAK}$
Highest allowable over-voltage (Transient over-voltage, $t_{TR} = 10$ sec)	$V_{TR}$	672	$V_{PEAK}$
Safety-limiting values (maximum value allowed in the event of a failure. See thermal derating curve, Figure 27)		4000	$V_{PEAK}$
Case temperature	TS		°C
Input current	$I_{S, INPUT}$		mA
Output current	$I_{S, OUTPUT}$		mA
Insulation resistance at $T_s$ , $V_{IO} = 500$ V	Rs	>10 <sup>9</sup>	Ω

## PIN CONFIGURATION AND FUNCTION DESCRIPTIONS

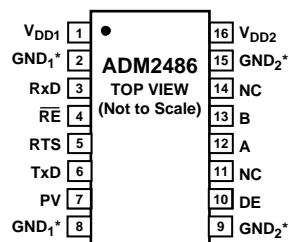

NC = NO CONNECT

**NOTE**

\*PINS 2 AND 8 ARE INTERNALLY CONNECTED.  
EITHER OR BOTH MAY BE USED FOR GND<sub>1</sub>.  
PINS 9 AND 15 ARE INTERNALLY CONNECTED.  
EITHER OR BOTH MAY BE USED FOR GND<sub>2</sub>.

04604-G-003

Figure 2. Pin Configuration

Table 8.

Pin No.	Mnemonic	Function
1	V <sub>DD1</sub>	Power Supply, Logic Side.
2, 8	GND <sub>1</sub>	Ground, Logic Side.
3	RxD	Receiver Output data. This output is high when (A – B) > 200 mV, and low when (A – B) < -200 mV. The output is tri-stated when the receiver is disabled, i.e. when $\overline{RE}$ is driven high.
4	$\overline{RE}$	Receiver Enable input. This is an active-low input. Driving this input low enables the receiver, while driving it high disables the receiver.
5	RTS	Request to Send Input. Driving this input high enables the driver, while driving it low disables the driver.
6	TxD	Transmit Data input. Data to be transmitted by the driver is applied to this input.
7	PV	Power Valid. Used during power-up and power-down. See the Applications Information section.
9, 15	GND <sub>2</sub>	Ground, Bus Side.
10	DE	Driver Enable Status Output. This output signals the driver enable or disable status to other devices on the bus. DE is high when the driver is enabled and low when the driver is disabled.
11, 14	NC	No Connect.
12	A	Noninverting Driver Output/Receiver Input. When the driver is disabled or V <sub>DD1</sub> or V <sub>DD2</sub> is powered down, pin A is put in a high impedance state to avoid overloading the bus.
13	B	Inverting Driver Output/Receiver Input. When the driver is disabled or V <sub>DD1</sub> or V <sub>DD2</sub> is powered down, pin B is put in a high impedance state to avoid overloading the bus.
16	V <sub>DD2</sub>	Power Supply, Bus Side.

## TEST CIRCUITS

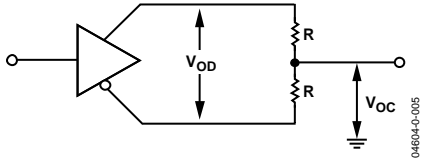

Figure 3. Driver Voltage Measurement

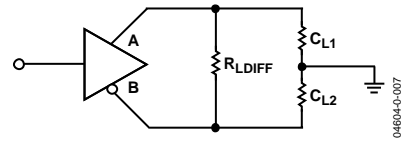

Figure 7. Driver Propagation Delay

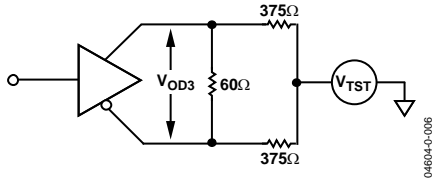

Figure 4. Driver Voltage Measurement

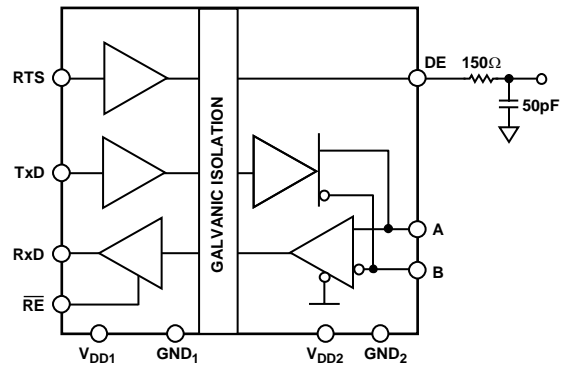

Figure 8. RTS to DE Propagation Delay

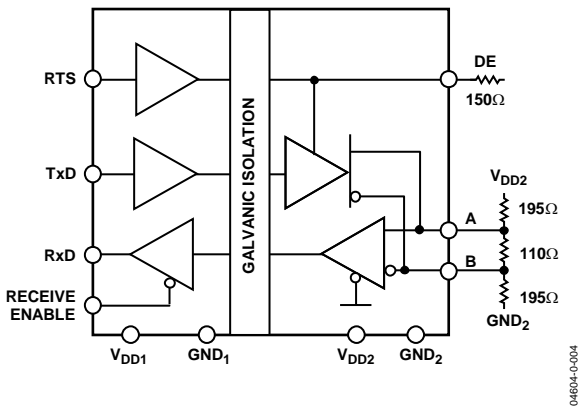

Figure 5. Supply-Current Measurement Test Circuit

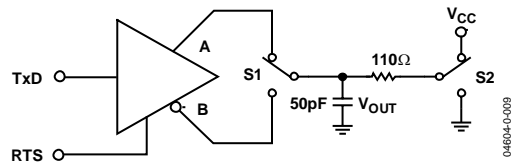

Figure 9. Driver Enable/Disable

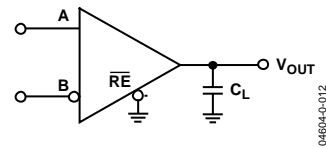

Figure 10. Receiver Propagation Delay

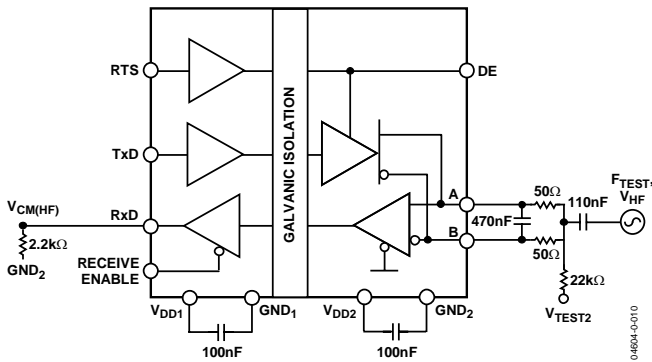

Figure 6. High Frequency Common-Mode Noise Test Circuit

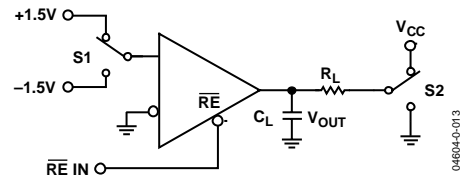

Figure 11. Receiver Enable/Disable

# SWITCHING CHARACTERISTICS

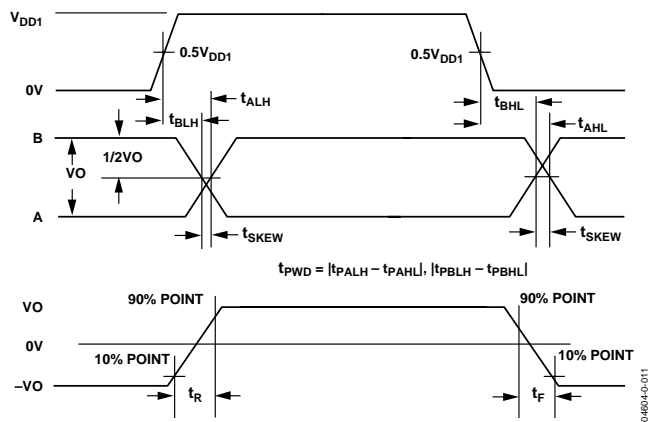

Figure 12. Driver Propagation Delay, Rise/Fall Timing

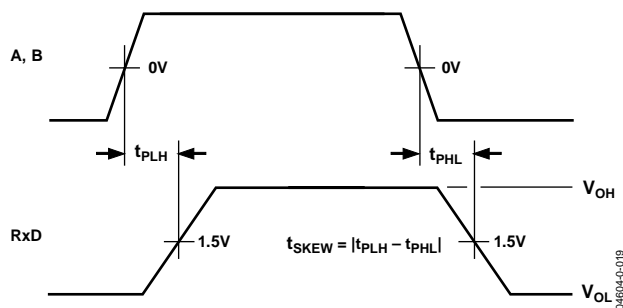

Figure 13. Receiver Propagation Delay

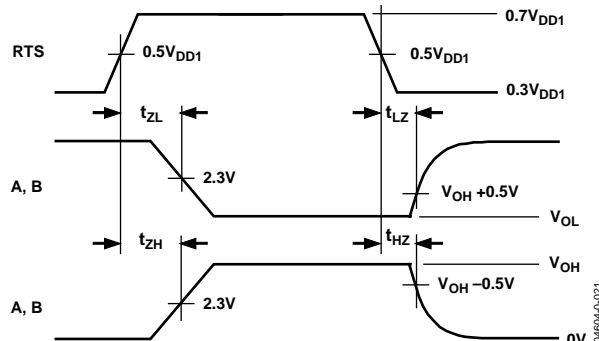

Figure 14. Driver Enable/Disable Timing

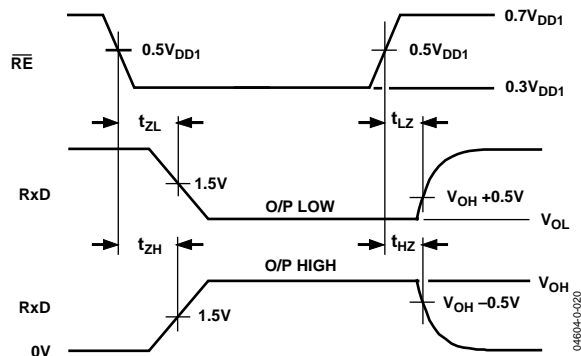

Figure 15. Receiver Enable/Disable Timing

## TYPICAL PERFORMANCE CHARACTERISTICS

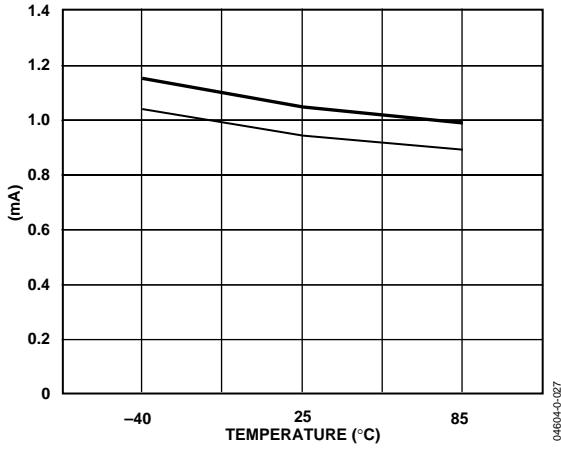

Figure 16. Unloaded Supply Current vs. Temperature

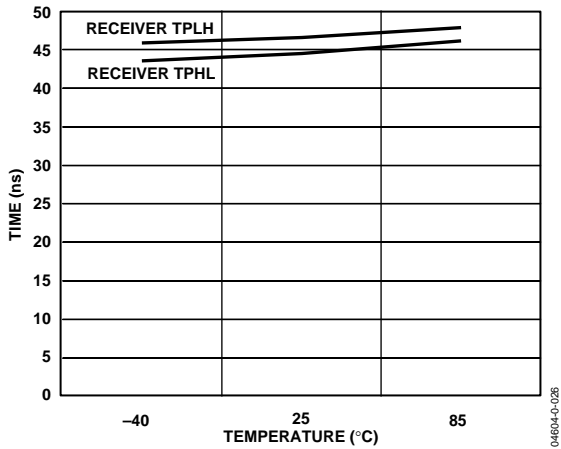

Figure 17. Driver Propagation Delay vs. Temperature

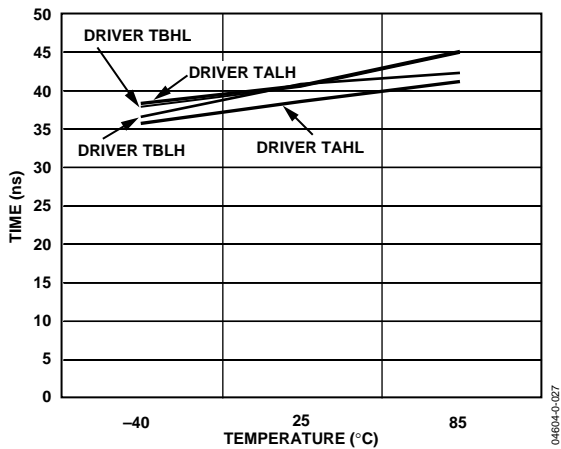

Figure 18. Receiver Propagation Delay vs. Temperature

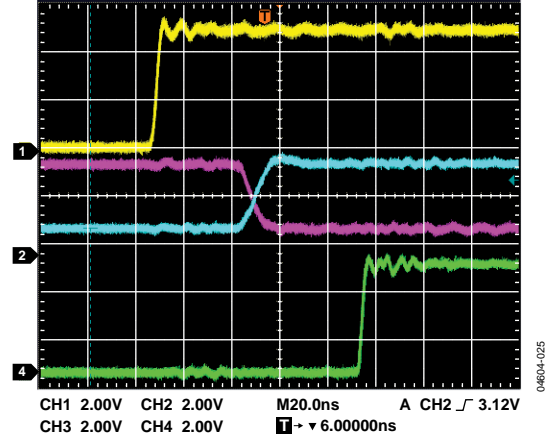

Figure 19. Driver/Receiver Propagation Delay, Low to High ( $R_{LDiff} = 54 \Omega$ ,  $C_{L1} = C_{L2} = 100 \text{ pF}$ )

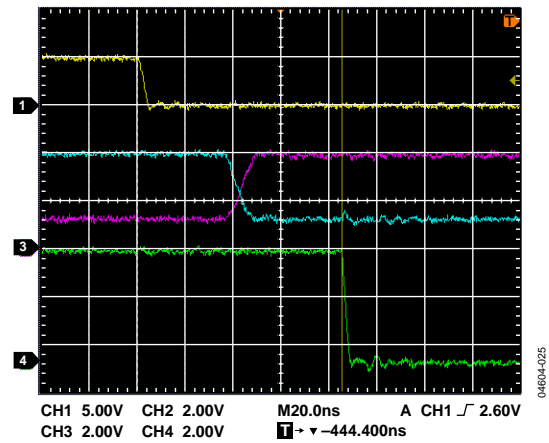

Figure 20. Driver/Receiver Propagation Delay, High to Low ( $R_{LDiff} = 54 \Omega$ ,  $C_{L1} = C_{L2} = 100 \text{ pF}$ )

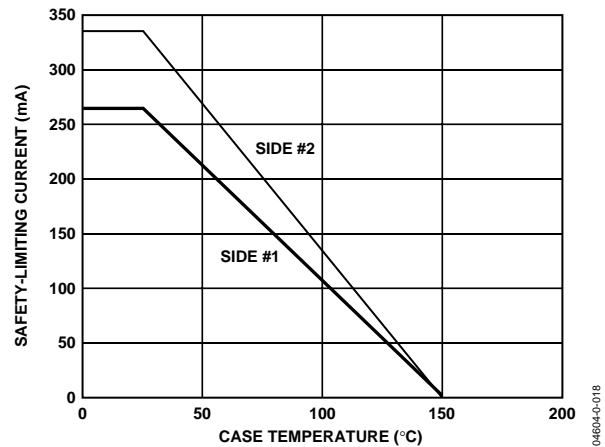

Figure 21. Thermal Derating Curve, Dependence of Safety-Limiting Values with Case Temperature per VDE 0884

## CIRCUIT DESCRIPTION

### ELECTRICAL ISOLATION

In the ADM2486, electrical isolation is implemented on the logic side of the interface. Therefore the part has two main sections: a digital isolation section and a transceiver section (see Figure 9). Driver input and request-to-send signals, applied to the TxD and RTS pins respectively and referenced to logic ground ( $GND_1$ ), are coupled across an isolation barrier to appear at the transceiver section referenced to isolated ground ( $GND_2$ ). Similarly, the receiver output, referenced to isolated ground in the transceiver section, is coupled across the isolation barrier to appear at the RxD pin referenced to logic ground.

#### iCoupler® Technology

The digital signals are transmitted across the isolation barrier using iCoupler® technology. This technique uses chip-scale transformer windings to couple the digital signals magnetically from one side of the barrier to the other. Digital inputs are encoded into waveforms which are capable of exciting the primary transformer winding. At the secondary winding, the induced waveforms are then decoded into the binary value that was originally transmitted.

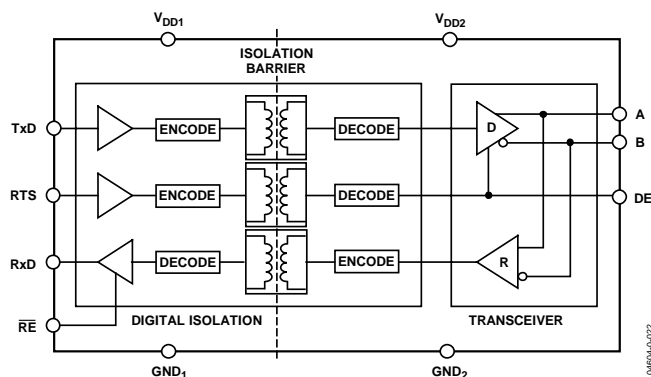

Figure 22. ADM2486 Digital Isolation and Transceiver Sections

### TRUTH TABLES

The truth tables in this section use these abbreviations:

Letter	Description
H	High level
I	Indeterminate
L	Low level
X	Irrelevant
Z	High impedance (off)
NC	Disconnected

Table 9. Transmitting

SUPPLY STATUS		INPUTS		OUTPUTS		
V <sub>DD1</sub>	V <sub>DD2</sub>	RTS	TxD	A	B	DE
On	On	H	H	H	L	H
On	On	H	L	L	H	H
On	On	L	X	Z	Z	L
On	Off	X	X	Z	Z	L
Off	On	X	X	Z	Z	L
Off	Off	X	X	Z	Z	L

Table 10. Receiving

SUPPLY STATUS		INPUTS		OUTPUT
V <sub>DD1</sub>	V <sub>DD2</sub>	A-B (V)	$\overline{RE}$	RxD
On	On	>0.2	L or NC	H
On	On	<-0.2	L or NC	L
On	On	-0.2 < A-B < 0.2	L or NC	I
On	On	Inputs open	L or NC	H
On	On	X	H	Z
On	Off	X	L or NC	H
Off	On	X	L or NC	H
Off	Off	X	L or NC	L

### POWER-UP/POWER-DOWN THRESHOLDS

The power-up/power-down characteristics of the ADM2486 are in accordance with the supply thresholds shown in Table 11. Upon power-up, the ADM2486 output signals (A, B, RxD, and DE) reach their correct state once both supplies have exceeded their thresholds. Upon power-down, the ADM2486 output signals retain their correct state until at least one of the supplies drops below its power-down threshold. When the V<sub>DD1</sub> power-down threshold is crossed, the ADM2486 output signals reach their unpowered states within 4  $\mu$ s.

Table 11. Power Up/Power-Down Thresholds

Supply	Transition	Threshold (V)
V <sub>DD1</sub>	Power Up	2.0
V <sub>DD1</sub>	Power Down	1.0
V <sub>DD2</sub>	Power Up	3.3
V <sub>DD2</sub>	Power Down	2.4

## THERMAL SHUTDOWN

The ADM2486 contains thermal shutdown circuitry that protects the part from excessive power dissipation during fault conditions. Shorting the driver outputs to a low impedance source can result in high driver currents. The thermal sensing circuitry detects the increase in die temperature under this condition and disables the driver outputs. This circuitry is designed to disable the driver outputs when a die temperature of 150°C is reached. As the device cools, the drivers are re-enabled at a temperature of 140°C.

## RECEIVER FAIL-SAFE INPUTS

The receiver input includes a fail-safe feature that guarantees a logic high RxD output when the A and B inputs are floating or open circuited.

## MAGNETIC FIELD IMMUNITY

The ADM2486 is immune to external magnetic fields. This immunity is set by the condition in which induced voltage in the transformer's receiving coil is sufficiently large to either falsely set or reset the decoder. The analysis that follows defines the conditions under which this may occur. The ADM2486's 3 V operating condition is examined as it represents the most susceptible mode of operation.

The pulses at the transformer output are greater than 1.0 V in amplitude. The decoder has sensing thresholds at about 0.5 V, therefore establishing a 0.5 V margin in which induced voltages can be tolerated. The induced voltage induced across the receiving coil is given by

$$V = \left( \frac{-d\beta}{dt} \right) \sum \pi r_n^2; n = 1, 2, \dots, N$$

where:

$\beta$  = magnetic flux density (Gauss)

$N$  = number of turns in receiving coil

$r_n$  = radius of nth turn in receiving coil (cm)

Given the geometry of the receiving coil and an imposed requirement that the induced voltage is at most 50% of the 0.5 V margin at the decoder, a maximum allowable magnetic field is calculated, as shown in Figure 23.

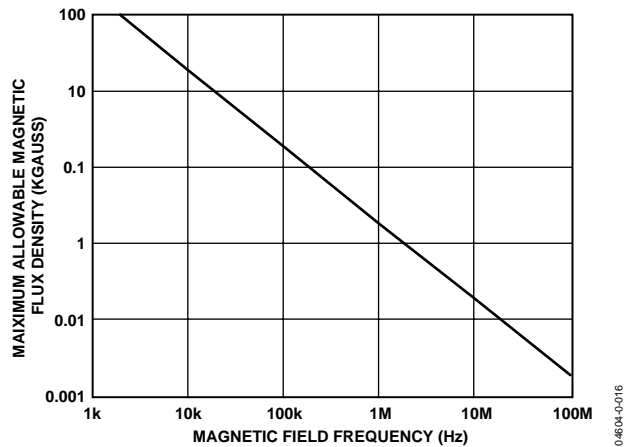

Figure 23. Maximum Allowable External Magnetic Flux Density

For example, at a magnetic field frequency of 1 MHz, the maximum allowable magnetic field of 0.2 kGauss induces a voltage of 0.25 V at the receiving coil. This is about 50% of the sensing threshold and does not cause a faulty output transition. Similarly, if such an event occurred during a transmitted pulse (and was of the worst-case polarity) it would reduce the received pulse from > 1.0 V to 0.75 V—still well above the 0.5 V sensing threshold of the decoder.

As a convenience to the user, Figure 24 shows the magnetic flux density values in terms of more familiar quantities such as maximum allowable current flow at given distances away from the ADM2486 transformers.

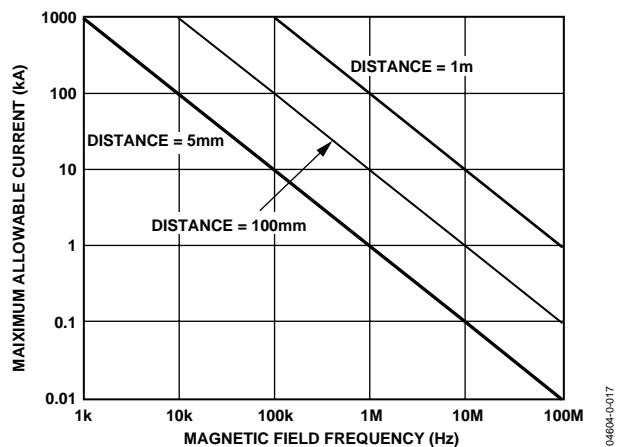

Figure 24. Maximum Allowable Current for Various Current-to-ADM2486 Spacings

Note that at combinations of strong magnetic field and high frequency, any loops formed by printed circuit board traces could induce sufficiently large error voltages to trigger the thresholds of succeeding circuitry. Care should be taken in the layout of such traces to avoid this possibility.

## APPLICATIONS INFORMATION

### POWER VALID INPUT

To avoid glitches on outputs A and B caused by slow power-up and power-down transients on  $V_{DD1}$  ( $> 100 \mu\text{s}/\text{V}$ ), the device features a power valid (PV) digital input. This pin should be driven low until  $V_{DD1}$  exceeds 2.0 V. When  $V_{DD1}$  is greater than 2.0 V, this pin should be driven high. Conversely, on power-down, PV should be driven low before  $V_{DD1}$  reaches 2.0 V.

The power valid input can be driven, for example, by the output of a system reset circuit such as the ADM809Z, which has a threshold voltage of 2.32 V.

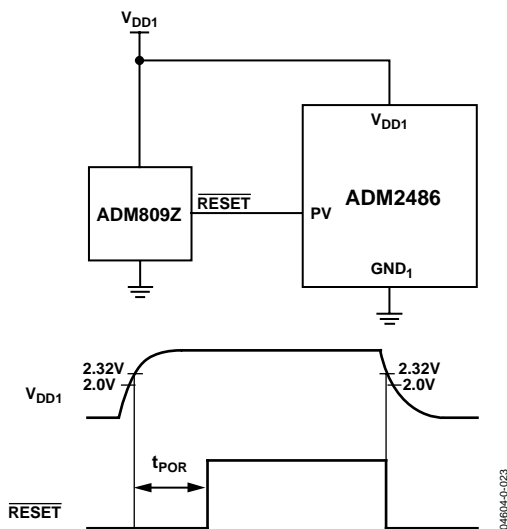

Figure 25. Driving PV with ADM809Z

### ISOLATED POWER-SUPPLY CIRCUIT

The ADM2486 requires isolated power capable of 5 V at 100 mA to be supplied between the  $V_{DD2}$  and  $\text{GND}_2$  pins. If no suitable integrated power supply is available, then a discrete circuit such as the one in Figure 26 can be used. A center tapped transformer provides electrical isolation. The primary winding is excited with a pair of square waveforms that are 180° out of phase with each other. A pair of Schottky diodes and a smoothing capacitor are used to create a rectified signal from the secondary winding. The ADP667 linear voltage regulator provides a regulated power supply to the ADM2486's bus-side circuitry.

To create the pair of square waves, a D-type flip-flop with complementary  $Q/\bar{Q}$  outputs is used. The flip-flop can be connected so that output Q follows the clock input signal. If no local clock signal is available, then a simple digital oscillator can be implemented with a hex-inverting Schmitt trigger and resistor and capacitor. In this case, values of 3.9 kΩ and 1 nF generate a 364 kHz square wave. A pair of discrete NMOS transistors, being switched by the  $Q/\bar{Q}$  flip-flop outputs, conduct current through the center tap of the primary transformer winding in an alternating fashion.

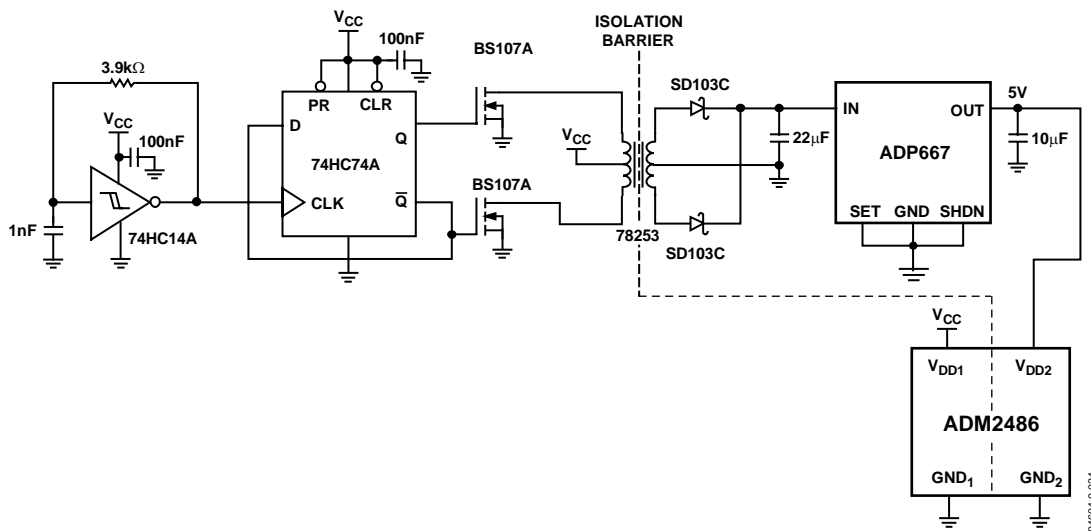
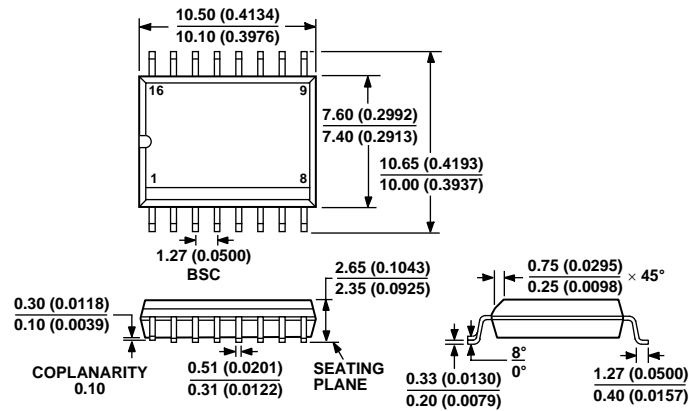

Figure 26. Isolated Power-Supply Circuit

## OUTLINE DIMENSIONS



COMPLIANT TO JEDEC STANDARDS MS-013AA  
CONTROLLING DIMENSIONS ARE IN MILLIMETERS; INCH DIMENSIONS  
(IN PARENTHESES) ARE ROUNDED-OFF MILLIMETER EQUIVALENTS FOR  
REFERENCE ONLY AND ARE NOT APPROPRIATE FOR USE IN DESIGN

Figure 27. 16-Lead Small Outline Package [SOIC]  
Wide Body  
(RW-16)

Dimensions shown in millimeters (and inches)

## ORDERING GUIDE

Model	Data Rate (Mbps)	Temperature Range	Package Description	Quantity	Package Option
ADM2486BRW	20	-40°C to +85°C	16-Lead Wide Body SOIC	47	RW-16
ADM2486BRW-REEL	20	-40°C to +85°C	16-Lead Wide Body SOIC	1000	RW-16