

FEATURES

- 10 V Output, $\pm 0.3\%$ Max
- Adjustment Range, $\pm 3\%$ Min
- Excellent Temperature Stability, 8.5 ppm/ $^{\circ}\text{C}$ Max
- Low Noise, 30 μV p-p Max
- Low Supply Current, 1.4 mA Max
- Wide Input Voltage Range, 12 V to 40 V
- High Load Driving Capability, 20 mA
- No External Components
- Short Circuit Proof

GENERAL DESCRIPTION

The REF01 precision voltage reference provides a stable 10 V output that can be adjusted over a 3% range with minimal effect on temperature stability. Single-supply operation over an input voltage range of 12 V to 40 V, a low current drain of 1 mA, and excellent temperature stability are achieved with an improved band gap design. Low cost, low noise, and low power make the REF01 an excellent choice whenever a stable voltage reference is required. Applications include D/A and A/D converters, portable instrumentation, and digital voltmeters. Full military temperature range devices with screening to MIL-STD-883 are available. For new designs, please refer to ADR01.

PIN CONFIGURATION

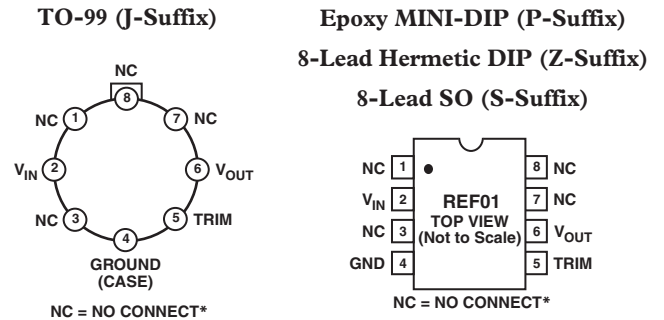

*NC = No Connect. Do not connect anything on these pins as some of them are reserved for factory testing purposes.

SIMPLIFIED SCHEMATIC

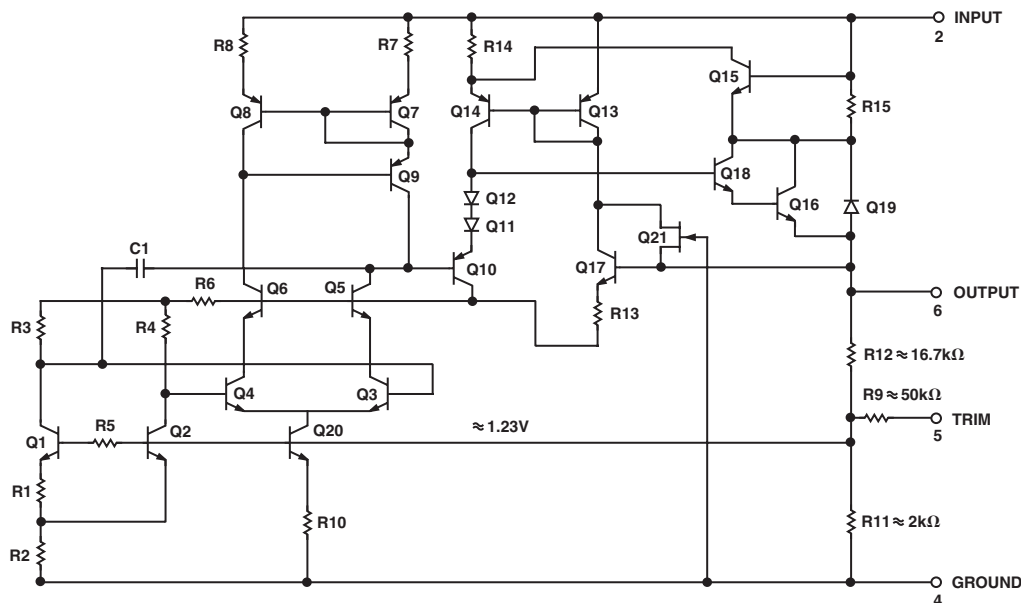

REV. C

Information furnished by Analog Devices is believed to be accurate and reliable. However, no responsibility is assumed by Analog Devices for its use, nor for any infringements of patents or other rights of third parties that may result from its use. No license is granted by implication or otherwise under any patent or patent rights of Analog Devices.

REF01—SPECIFICATIONS

ELECTRICAL SPECIFICATIONS (@ $V_{IN} = 15\text{ V}$, $T_A = 25^\circ\text{C}$, unless otherwise noted.)

Parameter	Symbol	Conditions	REF01A/E			REF01/H			Unit
			Min	Typ	Max	Min	Typ	Max	
Output Voltage	V_O	$I_L = 0\text{ mA}$	9.97	10.00	10.03	9.95	10.00	10.05	V
Output Adjustment Range	ΔV_{TRIM}	$R_P = 10\text{ k}\Omega$	± 3.0	± 3.3		± 3.0	± 3.3		%
Output Voltage Noise ¹	$e_{n\text{ p-p}}$	0.1 Hz to 10 Hz		20	30		20	30	$\mu\text{V p-p}$
Line Regulation ²		$V_{IN} = 13\text{ V to }33\text{ V}$		0.006	0.010		0.006	0.010	%/V
Load Regulation ²		$I_L = 0\text{ mA to }10\text{ mA}$		0.005	0.008		0.006	0.010	%/mA
Turn-On Settling Time ³	t_{ON}	$T_o \pm 0.1\%$ of Final Value		5			5		μs
Quiescent Supply Current	I_{SY}	No Load		1.0	1.4		1.0	1.4	mA
Load Current	I_L		10	21		10	21		mA
Sink Current ⁴	I_S		-0.3	-0.5		-0.3	-0.5		mA
Short Circuit Current	I_{SC}	$V_O = 0$		30			30		mA

ELECTRICAL SPECIFICATIONS (@ $V_{IN} = 15\text{ V}$, $-55^\circ\text{C} \leq T_A \leq +125^\circ\text{C}$ for REF01A/E, and $0^\circ\text{C} \leq T_A \leq 70^\circ\text{C}$ for REF01H and $I_L = 0\text{ mA}$, unless otherwise noted.)

Parameter	Symbol	Conditions	REF01A/E			REF01/H			Unit
			Min	Typ	Max	Min	Typ	Max	
Output Voltage Change with Temperature ^{5,6}	ΔV_{OT}	$0^\circ\text{C} \leq T_A \leq 70^\circ\text{C}$ $-55^\circ\text{C} \leq T_A \leq +125^\circ\text{C}$		0.02	0.06		0.07	0.17	%
Output Voltage Temperature Coefficient ⁷	TCV_O			0.06	0.15		0.18	0.45	%
Change in V_O Temperature Coefficient with Output Adjustment		$R_P = 10\text{ k}\Omega$		3.0	8.5		10.0	25.0	ppm/ $^\circ\text{C}$
Line Regulation ($V_{IN} = 13\text{ V to }33\text{ V}$) ²		$0^\circ\text{C} \leq T_A \leq 70^\circ\text{C}$ $-55^\circ\text{C} \leq T_A \leq +125^\circ\text{C}$		0.7			0.7		ppm/%
Load Regulation ($I_L = 0\text{ mA to }8\text{ mA}$) ²		$0^\circ\text{C} \leq T_A \leq 70^\circ\text{C}$ $-55^\circ\text{C} \leq T_A \leq +125^\circ\text{C}$		0.007	0.012		0.007	0.012	%/V
				0.009	0.015		0.009	0.015	%/V
				0.006	0.010		0.007	0.012	%/mA
				0.007	0.012		0.009	0.015	%/mA

ELECTRICAL SPECIFICATIONS (@ $V_{IN} = 15\text{ V}$, $T_A = 25^\circ\text{C}$, unless otherwise noted.)

Parameter	Symbol	Conditions	REF01C			Unit
			Min	Typ	Max	
Output Voltage	V_O	$I_L = 0\text{ mA}$	9.90	10.00	10.10	V
Output Adjustment Range	ΔV_{TRIM}	$R_P = 10\text{ k}\Omega$	± 2.7	± 3.3		%
Output Voltage Noise ¹	$e_{n\text{ p-p}}$	0.1 Hz to 10 Hz		25	35	$\mu\text{V p-p}$
Line Regulation ²		$V_{IN} = 13\text{ V to }33\text{ V}$		0.009	0.015	%/V
Load Regulation ²		$I_L = 0\text{ mA to }8\text{ mA}$		0.006	0.015	%/mA
Turn-On Settling Time ³	t_{ON}	$T_o \pm 0.1\%$ of Final Value		5		μs
Quiescent Supply Current	I_{SY}	No Load		1.0	1.6	mA
Load Current	I_L		8	21		mA
Sink Current ⁴	I_S		-0.3	-0.5		mA
Short Circuit Current	I_{SC}	$V_O = 0$		30		mA

ELECTRICAL SPECIFICATIONS

(@ $V_{IN} = 15\text{ V}$, $0^{\circ}\text{C} \leq T_A \leq 70^{\circ}\text{C}$ for REF01CJ, REF01CZ, and $-40^{\circ}\text{C} \leq T_A \leq +85^{\circ}\text{C}$ for REF01CP and REF01CS, unless otherwise noted.)

Parameter	Symbol	Conditions	REF01C			Unit
			Min	Typ	Max	
Output Voltage Change with Temperature ^{5, 6}	ΔV_{OT}			0.14	0.45	%
Output Voltage Temperature Coefficient ⁷	TCV_O			20	65	ppm/ $^{\circ}\text{C}$
Change in V_O Temperature Coefficient with Output Adjustment		$R_P = 10\text{ k}\Omega$		0.7		ppm/%
Line Regulation ²		$V_{IN} = 13\text{ V to }30\text{ V}$		0.011	0.018	%/V
Load Regulation ²		$I_L = 0\text{ to }5\text{ mA}$		0.008	0.018	%/mA

NOTES

¹Sample tested.²Line and load regulation specifications include the effect of self-heating.³Guaranteed by design.⁴During sink current test the device meets the output voltage specified.⁵ ΔV_{OT} is defined as the absolute difference between the maximum output voltage and the minimum output voltage over the specified temperature range expressed as a percentage of 10 V:

$$\Delta V_{OT} = \left| \frac{V_{MAX} - V_{MIN}}{10\text{ V}} \right| \times 100$$

⁶ ΔV_{OT} specification applies trimmed to +10,000 V or untrimmed.⁷ TCV_O is defined as ΔV_{OT} divided by the temperature range, i.e. $TCV_O(0^{\circ}\text{ to }70^{\circ}\text{ C}) = \frac{\Delta V_{OT}(0^{\circ}\text{ to }70^{\circ}\text{ C})}{70^{\circ}\text{ C}}$ and

$$TCV_O(-55^{\circ}\text{ to }125^{\circ}\text{ C}) = \frac{\Delta V_{OT}(-55^{\circ}\text{ to }125^{\circ}\text{ C})}{180^{\circ}\text{ C}}$$

Specifications are subject to change without notice.

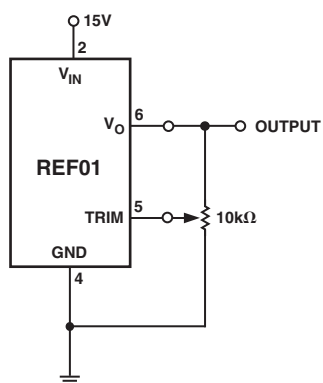

Figure 1. Output Adjustment

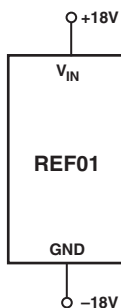
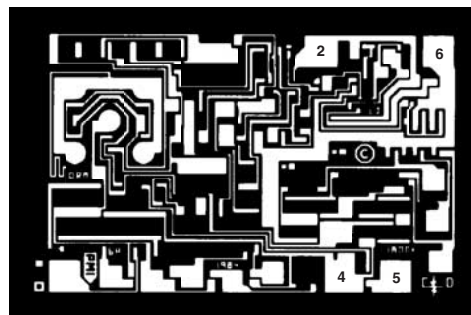

Figure 2. Burn-In Circuit

The REF01 trim terminal can be used to adjust the output voltage over a $10\text{ V} \pm 300\text{ mV}$ range. This feature allows the system designer to trim system errors by setting the reference to a voltage other than 10 V. Of course, the output can also be set to exactly 10.000 V or to 10.240 V for binary applications.

Adjustment of the output does not significantly affect the temperature performance of the device. The temperature coefficient change is approximately 0.7 ppm/ $^{\circ}\text{C}$ for 100 mV of output adjustment.

DIE SIZE 0.074 × 0.048 INCH, 3552 SQUARE MILS
(1.88 × 1.22 mm, 2.29 SQUARE mm)Figure 3. Dice Characteristics (125 $^{\circ}\text{C}$ Tested Dice Available)

2. INPUT VOLTAGE (V_{IN})
4. GROUND
5. TRIM
6. OUTPUT VOLTAGE (V_{OUT})

REF01

WAFER TEST LIMITS (@ $V_{IN} = 15\text{ V}$, $T_A = 25^\circ\text{C}$ for REF01N and REF01G devices, $T_A = 125^\circ\text{C}$ for REF01NT and REF01GT devices, unless otherwise noted.)*

Parameter	Symbol	Conditions	REF01NT Limit	REF01N Limit	REF01GT Limit	REF01G Limit	Unit
Output Voltage	V_O	$I_L = 0$	10.05 9.95	10.03 9.97	10.10 9.90	10.05 9.95	V max V min
Output Adjustment Range	V_{TRIM}	$R_P = 10\text{ k}\Omega$		± 3.0		± 3.0	% min
Line Regulation		$V_{IN} = 13\text{ V to }33\text{ V}$	0.015	0.01	0.015	0.01	%/V max

*Electrical tests are performed at wafer probe to the limits shown. Due to variations in assembly methods and normal yield loss, yield after packaging is not guaranteed for standard product dice. Consult factory to negotiate specifications based on dice lot qualification through sample lot assembly and testing.

TYPICAL ELECTRICAL CHARACTERISTICS (@ $V_{IN} = 15\text{ V}$, $T_A = 25^\circ\text{C}$, unless otherwise noted.)*

Parameter	Symbol	Conditions	REF01NT Typical	REF01N Typical	REF01GT Typical	REF01G Typical	Unit
Load Regulation		$I_L = 0\text{ mA to }10\text{ mA}$ $I_L = 0\text{ mA to }8\text{ mA}$, NT, GT @ 125°C	0.007	0.005	0.009	0.006	%/mA
Output Voltage Noise	$e_{n\text{ p-p}}$	0.1 Hz to 10 Hz	20	20	20	20	$\mu\text{V p-p}$
Turn-On Settling Time	t_{ON}	To $\pm 0.1\%$ of Final Value NT, GT @ 125°C	7.5	5.0	7.5	5.0	μs
Quiescent Current	I_{SY}	No Load, NT, GT @ 125°C	1.4	1.0	1.4	1.0	mA
Load Current	I_L		21	21	21	21	mA
Sink Current	I_S		-0.5	-0.5	-0.5	-0.5	mA
Short Circuit Current	I_{SC}	$V_O = 0$	30	30	30	30	mA
Output Voltage Temperature Coefficient	TCV_O		10	10	10	10	ppm/ $^\circ\text{C}$

*For 25°C specifications of REF01NT and REF01GT, see REF01N and REF01G, respectively.

ABSOLUTE MAXIMUM RATINGS*

Input Voltage	40 V
Output Short Circuit Duration (to Ground or V_{IN})	Indefinite
Storage Temperature Range	
J, RC, and Z Packages	-65°C to +150°C
P Package	-65°C to +125°C
Operating Temperature Range	
REF01A	-55°C to +125°C
REF01CJ	0°C to 70°C
REF01CP, REF01CS, REF01E, REF01H	-40°C to +85°C
Junction Temperature (T_J)	-65°C to +150°C
Lead Temperature (Soldering @ 60 sec)	300°C

*Absolute maximum ratings apply to both DICE and packaged parts, unless otherwise noted.

Package Type	θ_{JA} *	θ_{JC}	Unit
TO-99 (J)	170	24	°C/W
8-Pin Hermetic DIP (Z)	162	26	°C/W
8-Pin Plastic DIP (P)	110	50	°C/W
8-Pin SO (S)	160	44	°C/W

* θ_{JA} is specified for worst-case mounting conditions, i.e., θ_{JA} is specified for device in socket for TO, Cerdip, and P-DIP packages; θ_{JA} is specified for device soldered to printed circuit board for SO package.

ORDERING GUIDE¹

$T_A = 25^\circ\text{C}$ $\Delta V_{OS\text{ Max}}$ (mV)	TO-99	Package Description			Operating Temperature Range
		CERDIPS 8-Lead	PDIP 8-Lead	SOIC 8-Lead	
±30	REF01EJ	REF01AZ ²	REF01HP	REF01HS ³	MIL
±30		REF01EZ			XIND
±50		REF01HZ			XIND
±100	REF01CJ		REF01CP	REF01CS ³	COM
±100					XIND
±100					XIND

NOTES

¹Burn-in is available on commercial and industrial temperature range parts in Cerdip, plastic DIP, and TO-can packages.

²For devices processed in total compliance to MIL-STD-883, add 883 after part number. Consult factory for 883 data sheet.

³For availability and burn-in information on SO package, contact your local sales office.

CAUTION

ESD (electrostatic discharge) sensitive device. Electrostatic charges as high as 4000 V readily accumulate on the human body and test equipment and can discharge without detection. Although the REF01 features proprietary ESD protection circuitry, permanent damage may occur on devices subjected to high energy electrostatic discharges. Therefore, proper ESD precautions are recommended to avoid performance degradation or loss of functionality.



REF01—Typical Performance Characteristics

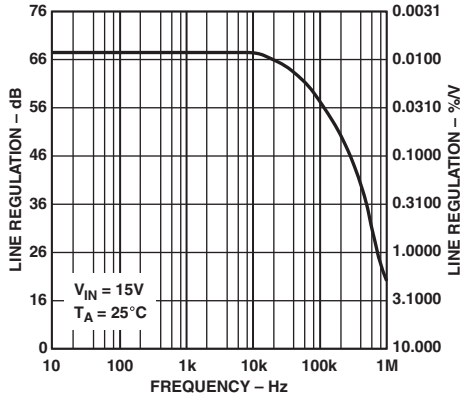

TPC 1. Line Regulation vs. Frequency

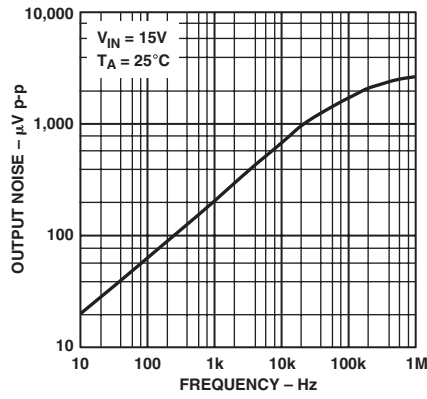

TPC 2. Output Wideband Noise vs. Bandwidth (0.1 Hz to Frequency Indicated)

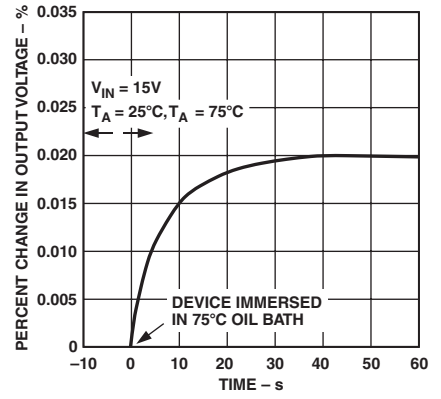

TPC 3. Output Change Due to Thermal Shock

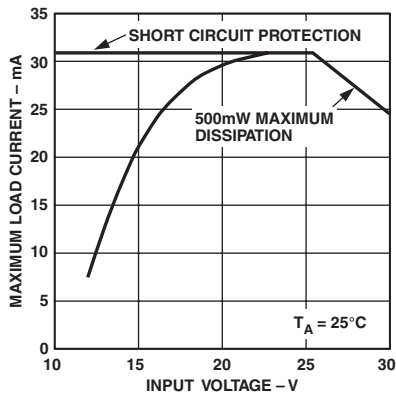

TPC 4. Maximum Load Current vs. Input Voltage

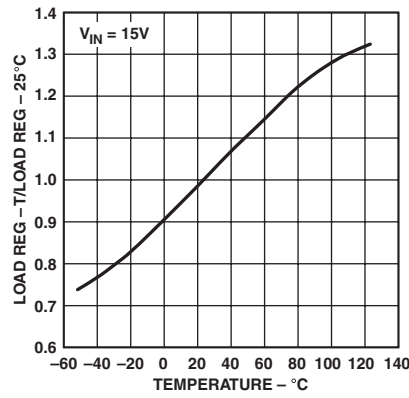

TPC 5. Normalized Load Regulation ($\Delta I_L = 10 \text{ mA}$) vs. Temperature

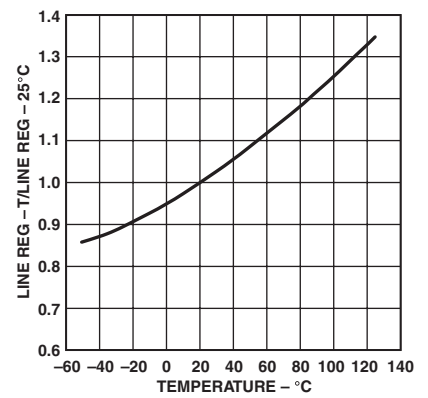

TPC 6. Normalized Line Regulation vs. Temperature

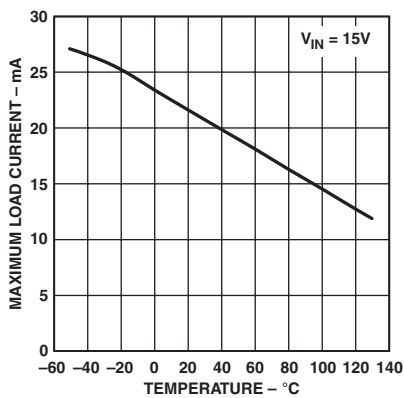

TPC 7. Maximum Load Current vs. Temperature

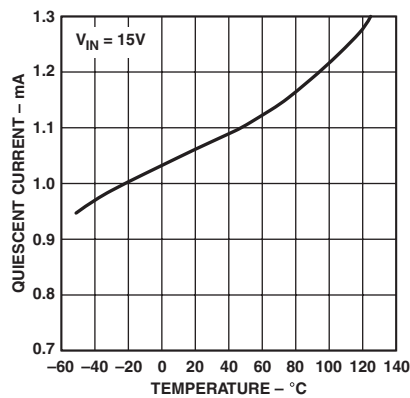

TPC 8. Quiescent Current vs. Temperature

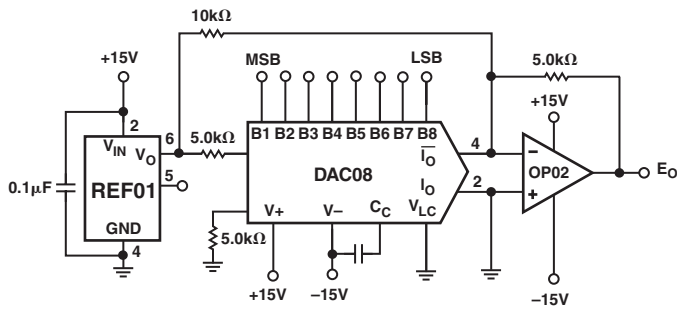

	B1	B2	B3	B4	B5	B6	B7	B8	E
POS. FULL SCALE -1LSB	1	1	1	1	1	1	1	1	+4.960
ZERO SCALE	1	0	0	0	0	0	0	0	0.000
NEG. FULL SCALE +1LSB	0	0	0	0	0	0	0	1	-4.960
NEG. FULL SCALE	0	0	0	0	0	0	0	0	-5.000

Figure 4. D/A Converter Reference

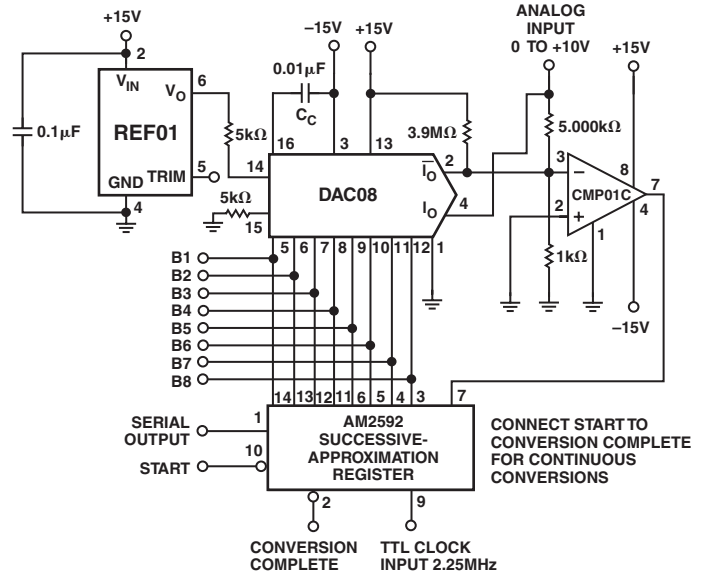

Figure 7. A/D Converter Reference

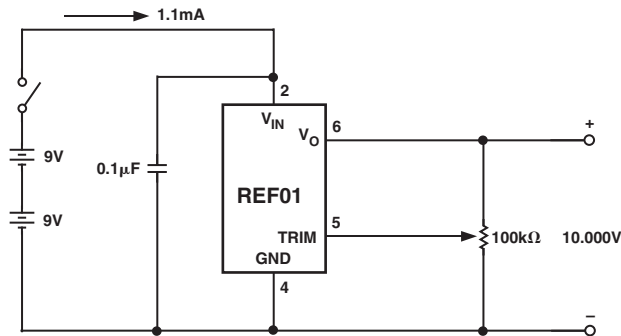

Figure 5. Precision Calibration Standard

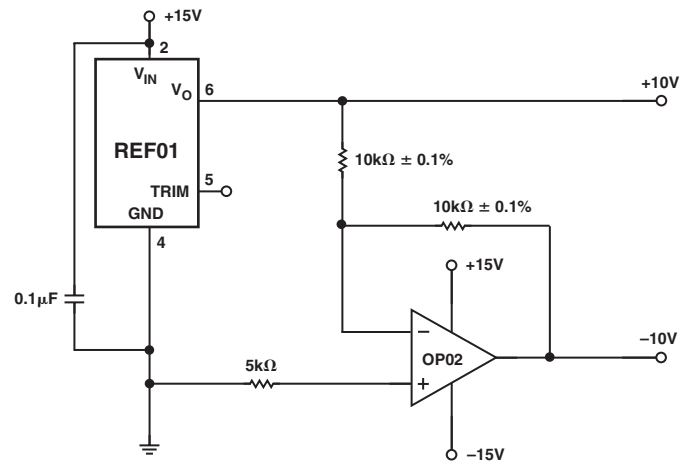

Figure 8. ±10 V Reference

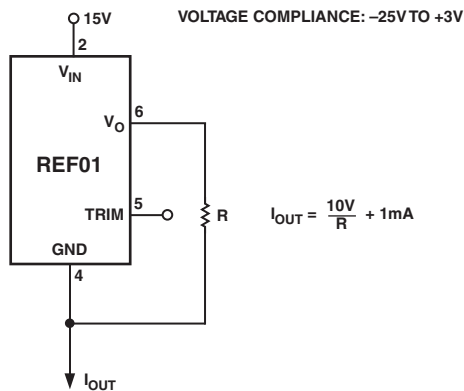

Figure 6. Current Source

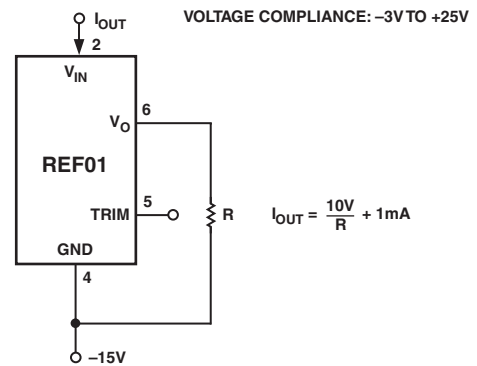

Figure 9. Current Sink

REF01

PRECISION CURRENT SOURCE

A current source with 25 V output compliance and excellent output impedance can be obtained using this circuit. REF01 keeps the line voltage and power dissipation constant in the device; the only important error consideration at room temperature is the negative supply rejection of the op amp. The typical $3 \mu\text{V}/\text{V}$ PSRR of the OP02E will create an 8 ppm change ($3 \mu\text{V}/\text{V} \times 25 \text{ V}/10 \text{ V}$) in output current over a 25 V range. For example, a 10 mA current source can be built ($R = 1 \text{ k}\Omega$) with $300 \text{ M}\Omega$ output impedance.

$$R_o = \frac{25 \text{ V}}{8 \times 10^{-6} \times 10 \text{ mA}}$$

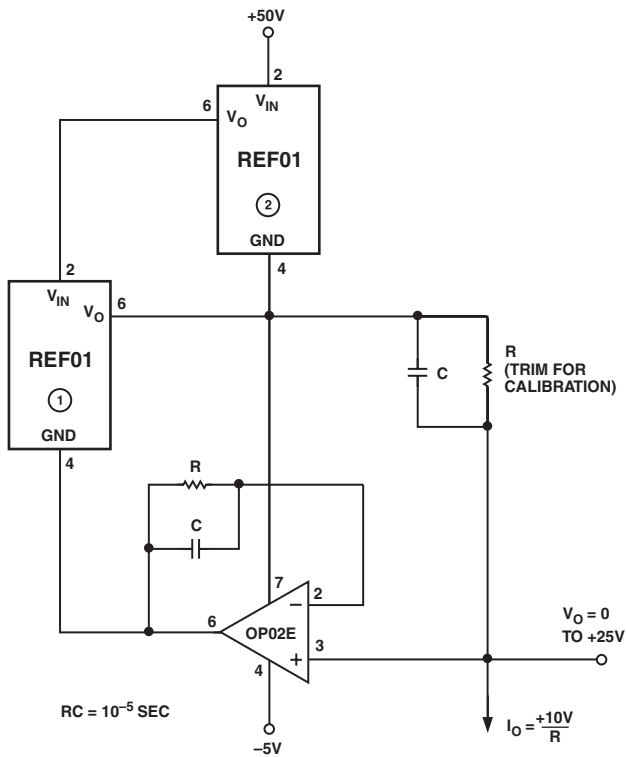

Figure 10. Precision Current Source

SUPPLY BYPASSING

For best results, it is recommended that the power supply pin is bypassed with a $0.1 \mu\text{F}$ disc ceramic capacitor.

REFERENCE STACK WITH EXCELLENT LINE REGULATION

Three REF01s can be stacked to yield 10.000 V, 20.000 V, and 30.000 V outputs. An additional advantage is near-perfect line regulation of the 10.0 V and 20.0 V output. A 32 V to 60 V input change produces an output change that is less than the noise voltage of the devices. A load bypass resistor (R_B) provides a path for the supply current (I_{SY}) of the 20.000 V regulator.

In general, any number of REF01s can be stacked this way. For example, 10 devices will yield outputs of 10, 20, 30 . . . 100 V. The line voltage can change from 105 V to 130 V. However, care must be taken to ensure that the total load currents do not exceed the maximum usable current (typically 21 mA).

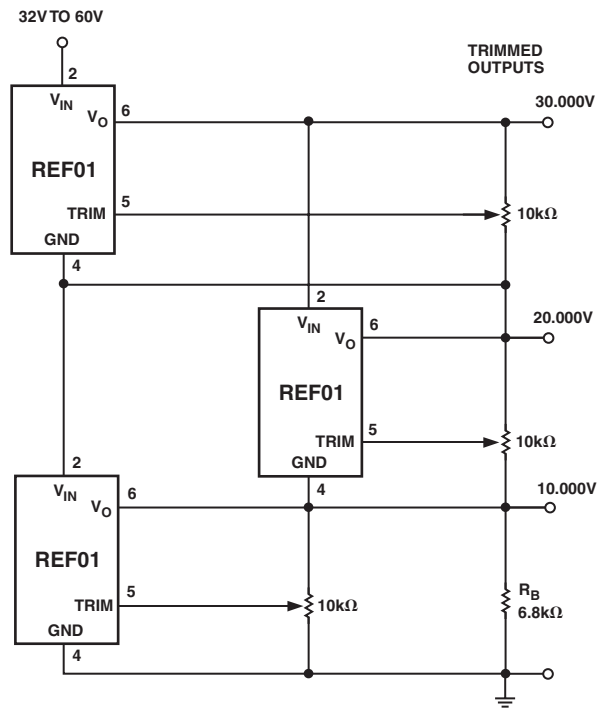
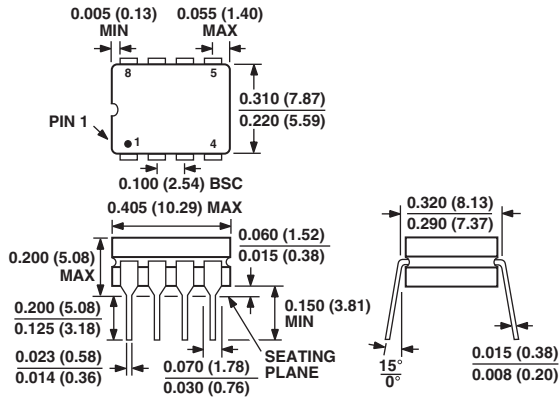

Figure 11. Reference Stack

OUTLINE DIMENSIONS

8-Lead Ceramic Dip-Glass Hermetic Seal [CERDIP]
(Q-8)

Dimensions shown in inches and (millimeters)



CONTROLLING DIMENSIONS ARE IN INCH; MILLIMETERS DIMENSIONS (IN PARENTHESES) ARE ROUNDED-OFF MILLIMETER EQUIVALENTS FOR REFERENCE ONLY AND ARE NOT APPROPRIATE FOR USE IN DESIGN

8-Lead Metal Can [TO-99]
(H-08B)

Dimensions shown in inches and (millimeters)

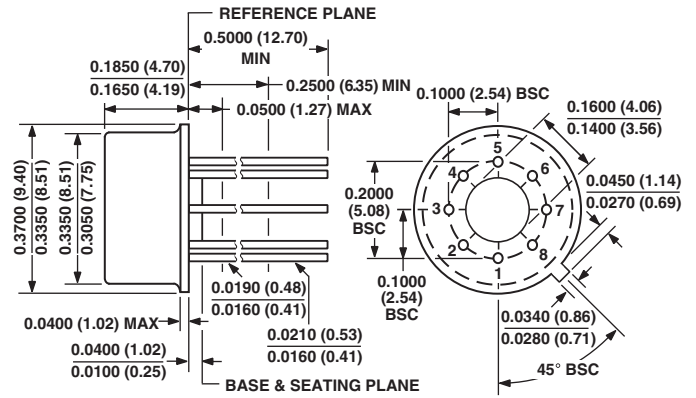

COMPLIANT TO JEDEC STANDARDS MO-002AK
CONTROLLING DIMENSIONS ARE IN INCHES; MILLIMETERS DIMENSIONS (IN PARENTHESES) ARE ROUNDED-OFF EQUIVALENTS FOR REFERENCE ONLY AND ARE NOT APPROPRIATE FOR USE IN DESIGN

8-Lead Standard Small Outline Package [SOIC]
Narrow Body
(R-8)

Dimensions shown in millimeters and (inches)

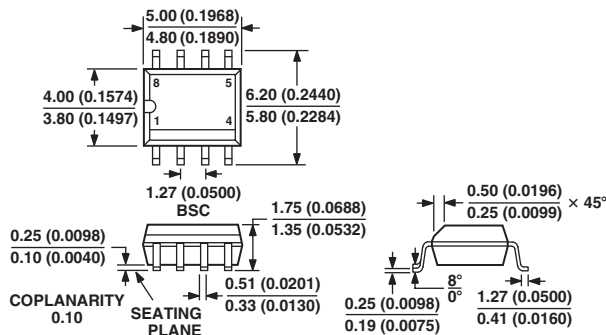

COMPLIANT TO JEDEC STANDARDS MS-012AA
CONTROLLING DIMENSIONS ARE IN MILLIMETERS; INCH DIMENSIONS (IN PARENTHESES) ARE ROUNDED-OFF MILLIMETER EQUIVALENTS FOR REFERENCE ONLY AND ARE NOT APPROPRIATE FOR USE IN DESIGN

8-Lead Plastic Dual-in-Line Package [PDIP]
(N-8)

Dimensions shown in inches and (millimeters)

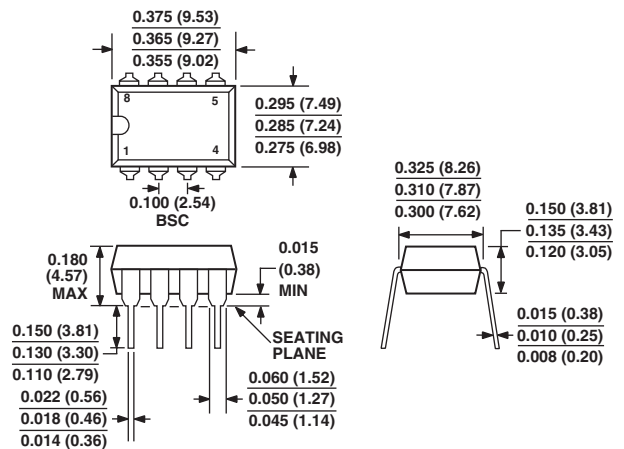

COMPLIANT TO JEDEC STANDARDS MO-095AA
CONTROLLING DIMENSIONS ARE IN INCHES; MILLIMETERS DIMENSIONS (IN PARENTHESES)

REF01

Revision History

Location	Page
10/02—Data Sheet changed from REV. B to REV. C.	
Edits to FEATURES	1
Delete RC-SUFFIX	1
Edits to ABSOLUTE MAXIMUM RATINGS	5
Edits to ORDERING GUIDE	5
Edits to Package Type	5
Delete CP-20	9
Updated OUTLINE DIMENSIONS	9

