



1.0 SCOPE

This specification documents the detailed requirements for Analog Devices space qualified die including die qualification as described for Class K in MIL-PRF-38534, Appendix C, Table C-II except as modified herein.

The manufacturing flow described in the STANDARD DIE PRODUCTS PROGRAM brochure at <http://www.analog.com/aerospace> is to be considered a part of this specification.

This data sheet specifically details the space grade version of this product.

2.0 Part Number. The complete part number(s) of this specification follow:

<u>Part Number</u>	<u>Description</u>
REF01-000C	Linear, Positive 10-Volt Adjustable Precision Voltage Reference
REF01R000C	Radiation tested Linear, Positive 10-Volt Adjustable Precision Voltage Ref.

2.1 Die Information

2.1.1 Die Dimensions

Die Size	Die Thickness	Bond Pad Metalization
74.2 mil x 51.8 mil	19 mil ± 2 mil	Al/Cu

2.1.2 Die Picture

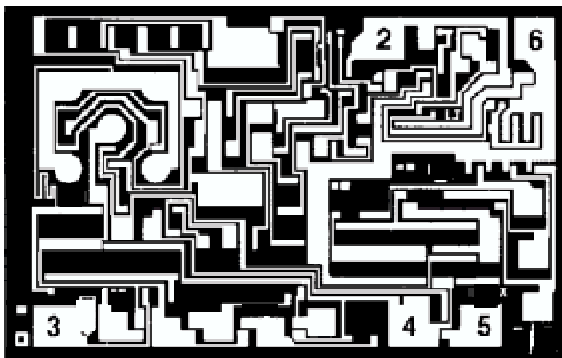

- 1. NC
- 2. V_{IN}
- 3. NC
- 4. GND
- 5. TRIM
- 6. V_{OUT}
- 7. NC
- 8. NC

Figure 1 - Terminal connections.

3.0 Absolute Maximum Ratings ^{1/}

Input Voltage (V_{IN}).....	40V dc
Output Short Circuit Duration	Indefinite
Storage Temperature.....	-65°C to +150°C
Junction Temperature (T_J).....	150°C
Ambient Operating Temperature Range (T_A)	-55°C to +125°C

4.0 Die Qualification

In accordance with class-K version of MIL-PRF-38534, Appendix C, Table C-II, except as modified herein.

- (a) Qual Sample Size and Qual Acceptance Criteria – 25/2
- (b) Qual Sample Package – DIP
- (c) Pre-screen electrical test over temperature performed post-assembly prior to die qualification.

Table I - Dice Electrical Characteristics					
Parameter	Symbol	Conditions ^{1/}	Limit Min	Limit Max	Units
Quiescent Supply Current	I_{SY}	$I_L = 0mA$		1.35	mA
Output Adjustment Range	ΔV_{TRIM}	$V_{REF} = 0, 10V$ $R_P = 10k\Omega$	± 3.0	± 99	%
Output Voltage	V_O	$I_{SINK} = 300\mu A$	9.952	9.995	V
		$I_L = 0mA$	9.95	9.98	
Line Regulation	LN_{reg}	$V_{IN} = 13V$ to $33V$	0	0.01	%/V

Table I Notes:

^{1/} $V_{IN} = 15V, T_A = 25^\circ C$, unless otherwise specified. No external components required. Refer to section 6.0 Application Notes for more external trim details.

Table II - Electrical Characteristics for Qual Samples						
Parameter	Symbol	Conditions <u>1/</u> <u>2/</u> <u>3/</u> -55°C ≤ T _A ≤ 125°C unless otherwise specified	Sub-groups	Limit Min	Limit Max	Units
Quiescent Supply Current	ISY	No Load	1		1.4	mA
			2, 3		2	
		M, D, P, L, R	1		1.4	
Output Adjustment Range	ΔVTRIM	RP = 10kΩ <u>4/</u> , T _A = 25°C	1	±3.0		%
Output Voltage	VO	IL = 0mA	1	9.95	10.05	V
			2, 3	9.905	10.095	
		M, D, P, L, R	1	9.94	10.06	
Short Circuit Current	IOS	VO = 0V, T _A = 25°C <u>4/</u>	1	15	60	mA
Sink Current	IS	T _A = 25°C <u>4/</u>	1	-0.3		mA
Load Regulation	LDreg	IL = 0mA to 10mA <u>5/</u> <u>6/</u>	1		0.01	% / mA
			M, D, P, L, R	1		
		IL = 0mA to 8mA <u>5/</u> <u>6/</u>	2, 3		0.015	
Line Regulation	LNreg	V _{IN} = 13V to 33V <u>5/</u>	1		0.01	% / V
			2, 3		0.015	
		M, D, P, L, R	1		0.03	
Load Current	IL	T _A = 25°C <u>4/</u> <u>7/</u>	1	10		mA
			2, 3	8		
Output voltage noise	enp-p	0.1 Hz to 10Hz <u>4/</u>	4		150	μVp-p
Output Voltage Temperature Coefficient	TCVO	-55°C ≤ T _A ≤ 125°C <u>4/</u> <u>8/</u>	5, 6		±25	ppm/°C

Table II Notes:

- 1/ V_{IN} = 15V, unless otherwise specified. No external components required.
- 2/ Devices supplied to this drawing meet all levels M, D, P, L, and R of irradiation however this device is only tested at the R level. Pre and post irradiation values are identical unless otherwise specified in table II. When performing post irradiation electrical measurements for any RHA level, T_A = 25°C.
- 3/ These parts may be dose rate sensitive in a space environment and may demonstrate low dose rate effects. Radiation end point limits for the noted parameters are guaranteed only for the conditions specified in MIL-STD-883, method 1019, condition A.
- 4/ Not tested post irradiation. Refer to section 6.0 Application Notes for more external trim details.
- 5/ Line and Load regulation specifications include the effect of self-heating.
- 6/ LDreg = (ΔVOUT / ΔIOUT) / VOUT x 100 = % / mA
- 7/ Minimum load current guaranteed by load regulation test.
- 8/ TCVo = ABS ((VMAX - VMIN) / 10V) x (1 / 180°C) x (10⁶) where -55°C ≤ T_A ≤ 125°C.

Table III - Endpoint and Delta Limits (+25°C)						
(Product is tested in accordance with Table II with the following exceptions)						
Parameter	Symbol	Sub-groups	End-point		Delta	Units
			Min	Max		
Output Voltage	VO	1	9.95	10.05	±0.006	V

5.0 Life Test/Burn-In Information

- 5.1 HTRB is not applicable for this drawing.
- 5.2 Burn-in is per MIL-STD-883 Method 1015 test condition B.
- 5.3 Steady state life test is per MIL-STD-883 Method 1005

6.0 Application Note

- 6.1 No external components required.
- 6.2 The REF01 trim terminal can be used to adjust the output voltage over a 10V ±300mV range. This feature allows the system designer to trim system errors by setting the reference to a voltage other than 10V. Of course, the output can also be set to exactly 10.000V, or to 10.240V for binary applications.

Adjustment of the output does not significantly affect the temperature performance of the device. Typically, the temperature coefficient change is 0.7ppm/°C for 100mV of output adjustment.

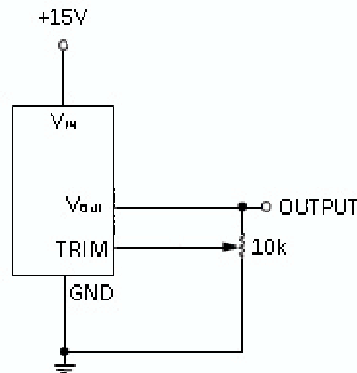

Vout Trim Circuit

Rev	Description of Change	Date
A	Initiate	12-MAR-2008
B	Update document format.	6-JAN-2009
C	Updated Section 4.0c note to indicate pre-screen temp testing being performed.	5-JUN-2009
D	Removed "ADI INTERNAL USE" from page 1 of ASD	13-JUL-2009
E	Updated fonts and sizes to ADI standard	7- Oct-2011
F	Added Application note for no external components required	13-Dec-2013