



+5V Precision Voltage Reference/ Temperature Transducer

REF02

1.0 SCOPE

This specification documents the detailed requirements for Analog Devices space qualified die including die qualification as described for Class K in MIL-PRF-38534, Appendix C, Table C-II except as modified herein.

The manufacturing flow described in the STANDARD DIE PRODUCTS PROGRAM brochure at <http://www.analog.com/aerospace> is to be considered a part of this specification.

This data sheet specifically details the space grade version of this product.

Part Number. The complete part number(s) of this specification follow:

<u>Part Number</u>	<u>Description</u>
REF02-000C	+5V Precision Voltage Reference / Temperature Transducer
REF02R000C	Radiation tested +5V Precision Voltage Reference

2.0 Die Information

2.1 Die Dimensions

Die Size	Die Thickness	Bond Pad Metalization
48 mil x 74 mil	19 mil \pm 2 mil	Al/Cu

3.2 Die Picture

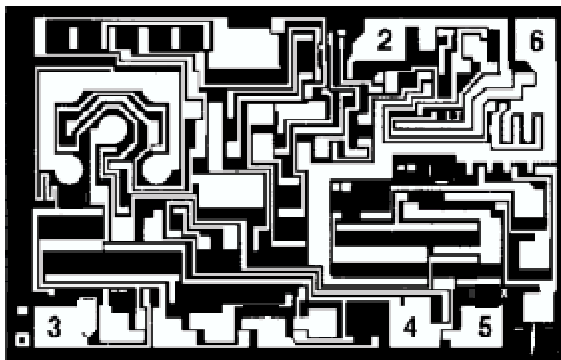

1. NC
2. V_{IN}
3. TEMP
4. GND
5. TRIM
6. V_{OUT}
7. NC
8. NC

ASD0012333

Rev. G

Information furnished by Analog Devices is believed to be accurate and reliable. However, no responsibility is assumed by Analog Devices for its use, nor for any infringements of patents or other rights of third parties that may result from its use. Specifications subject to change without notice. No license is granted by implication or otherwise under any patent or patent rights of Analog Devices. Trademarks and registered trademarks are the property of their respective companies.

One Technology Way, P.O. Box 9106, Norwood, MA 02062-9106, U.S.A.
Tel: 781.329.4700 www.analog.com
Fax: 781.326.8703 © 2013 Analog Devices, Inc. All rights reserved.

3.3 Absolute Maximum Ratings ^{1/}

Input Voltage (V _{IN})	40V dc
Output Short Circuit Duration	Indefinite
Storage Temperature	-65°C to +150°C
Ambient Operating Temperature Range (T _A)	-55°C to +125°C
Junction Temperature (T _J).....	150°C

Absolute Maximum Ratings Notes:

^{1/} Stresses above the absolute maximum rating may cause permanent damage to the device. Extended operation at the maximum levels may degrade performance and affect reliability.

4.0 Die Qualification

In accordance with class-K version of MIL-PRF-38534, Appendix C, Table C-II, except as modified herein.

- (a) Qual Sample Size and Qual Acceptance Criteria – 25/2
- (b) Qual Sample Package – DIP
- (c) Pre-screen electrical test over temperature performed post-assembly prior to die qualification.

Table I - Dice Electrical Characteristics

Parameter	Symbol	Conditions ^{1/}	Limit Min	Limit Max	Units
Quiescent Supply Current	I _{SY}	No Load		1.4	mA
Output Adjustment Range	ΔV _{TRIM}	R _P = 10kΩ	±3.0		%
Output Voltage	V _O	I _L = 0mA	4.985	5.015	V
Line Regulation	LN _{REG}	V _{IN} = 8V to 33V		0.010	%/V

Table I Notes:

^{1/} V_{IN} = 15V, T_A = 25°C, unless otherwise specified. No external components required. Refer to section 6.0 Application Notes for more external trim details.

Table II - Electrical Characteristics for Qual Samples						
Parameter	Symbol	Conditions 1/	Sub- groups	Limit Min	Limit Max	Units
Quiescent Supply Current	I _{SY}	No Load	1		1.4	mA
			2, 3		2.0	
		M, D, L, R 5/	1		1.4	
Output Adjustment Range 6/	ΔV _{TRIM}	R _P = 10kΩ	1	±3.0		%
Output Voltage	V _O	I _L = 0mA	1	4.985	5.015	V
			2, 3	4.978	5.022	
		M, D, L, R 5/	1	4.975	5.025	
Short Circuit Current 6/	I _{OS}	V _O = 0V	1	+15	+60	mA
Sink Current 6/	I _S		1	-0.3		mA
Load Regulation 2/	LD _{reg}	I _L = 0mA to 10mA	1		0.010	%mA
			M, D, L, R 5/	1		
		I _L = 0mA to 8mA	2, 3		0.012	
Line Regulation 2/	LN _{reg}	V _{IN} = 8V to 33V	1		0.010	%V
			2, 3		0.015	
		M, D, L, R 5/	1		0.030	
Load Current 6/	I _L	3/	1	10		mA
Output Voltage Temperature Coefficient 6/	TCV _O	4/	8		±15	ppm/°C

Table II Notes:

- 1/ V_{IN} = 15V, unless otherwise specified. No external components required.
- 2/ Line and Load Regulation specifications include effect of self heating.
- 3/ Minimum of 10mA Load Current guaranteed by Load Regulation test.
- 4/ TCV_O = ABS (V_{MAX} - V_{MIN}) / (5V * 180°C * 10⁻⁶) where -55°C ≤ T_A ≤ 125°C.
- 5/ Radiation tested to 100Krad.
- 6/ Not tested post irradiation. Refer to section 6.0 Application Notes for more external trim details.

Table III - Life Test Endpoint and Delta Parameter
 (Product is tested in accordance with Table II with the following exceptions)

Parameter	Symbol	Sub-groups	Post Burn In Limit		Post Life Test Limit		Life Test Delta	Units
			Min	Max	Min	Max		
Output Voltage	V _o	1	4.979	5.021	4.973	5.027	±0.006	V
		2, 3			4.966	5.034		

5.0 Life Test/Burn-In Information

- 5.1 HTRB is not applicable for this drawing.
- 5.2 Burn-in is per MIL-STD-883 Method 1015 test condition B.
- 5.3 Steady state life test is per MIL-STD-883 Method 1005.

6.0 Application Note

- 6.1 No external components required.
- 6.2 The REF02 trim terminal can be used to adjust the output voltage over a 5V ±300mV range. This feature allows the system designer to trim system errors by setting the reference to a voltage other than 5V. Of course, the output can also be set to exactly 5.000V, or to 5.12V for binary applications.

Adjustment of the output does not significantly affect the temperature performance of the device. Typically, the temperature coefficient change is 0.7ppm/°C for 100mV of output adjustment.

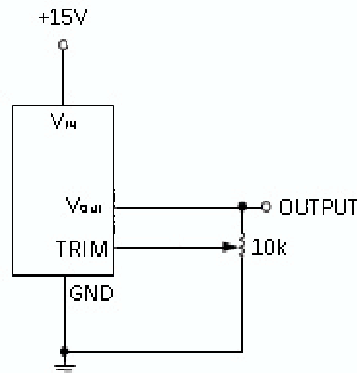

Vout Trim Circuit

Rev	Description of Change	Date
A	Initiate	20-DEC-01
B	Update web address. Add radiation part number and limits.	May 29, 2003
C	Update header/footer & add to 1.0 Scope description.	Feb. 26, 2008
D	Add Junction Temperature....150°C to 3.3 Absolute Max Ratings	March 27, 2008
E	Updated Section 4.0c note to indicated pre-screen temp testing being performed.	June 5, 2009
F	Updated fonts and sizes to ADI standard	Oct 7, 2011
G	Added application note for no external components required	Dec. 16, 2013