

MMBT2907A

Features

- Epitaxial Planar Die Construction
- Complementary NPN Type Available (MMBT2222A)
- Ideal for Medium Power Amplification and Switching

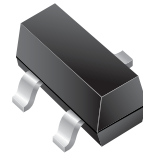

Mechanical Data

- Case:** SOT-23 Plastic Package
- Weight:** approx. 0.008g

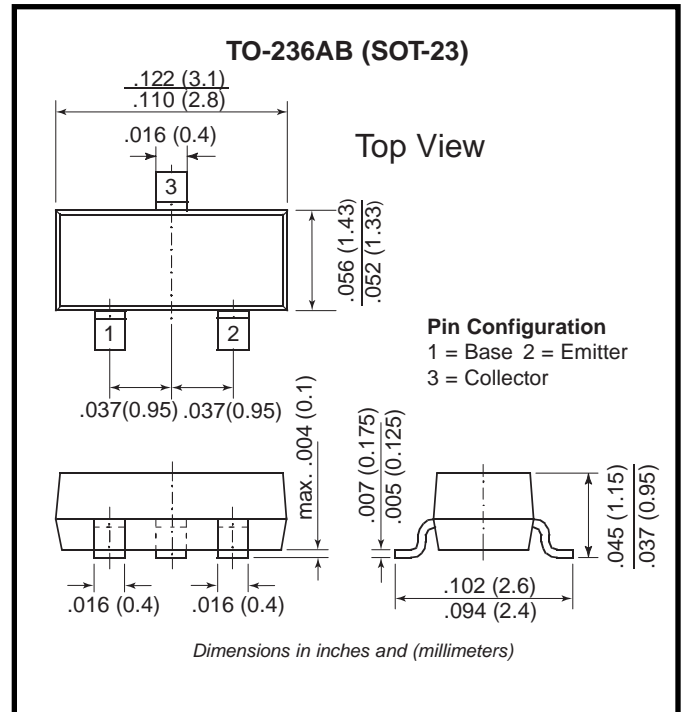
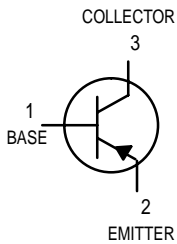

Maximum Ratings & Thermal Characteristics Ratings at 25°C ambient temperature unless otherwise specified.

Rating	Symbol	2907	2907A	Unit
Collector–Emitter Voltage	V_{CEO}	-40	-60	Vdc
Collector–Base Voltage	V_{CBO}	-60		Vdc
Emitter–Base Voltage	V_{EBO}	-5.0		Vdc
Collector Current — Continuous	I_C	-600		mAdc

Characteristic	Symbol	Max	Unit
Total Device Dissipation FR-5 Board ⁽¹⁾ $T_A = 25^\circ\text{C}$ Derate above 25°C	P_D	225 1.8	mW mW/°C
Thermal Resistance, Junction to Ambient	$R_{\theta JA}$	556	°C/W
Total Device Dissipation Alumina Substrate, ⁽²⁾ $T_A = 25^\circ\text{C}$ Derate above 25°C	P_D	300 2.4	mW mW/°C
Thermal Resistance, Junction to Ambient	$R_{\theta JA}$	417	°C/W
Junction and Storage Temperature	T_J, T_{stg}	-55 to +150	°C

General Purpose Transistor (PNP)

ELECTRICAL CHARACTERISTICS ($T_A = 25^\circ\text{C}$ unless otherwise noted)

Characteristic		Symbol	Min	Max	Unit
OFF CHARACTERISTICS					
Collector–Emitter Breakdown Voltage ⁽³⁾ ($I_C = -10\text{ mAdc}$, $I_B = 0$)	MMBT2907 MMBT2907A	$V_{(BR)CEO}$	-40 -60	— —	Vdc
Collector–Base Breakdown Voltage ($I_C = -10\ \mu\text{Adc}$, $I_E = 0$)		$V_{(BR)CBO}$	-60	—	Vdc
Emitter–Base Breakdown Voltage ($I_E = -10\ \mu\text{Adc}$, $I_C = 0$)		$V_{(BR)EBO}$	-5.0	—	Vdc
Collector Cutoff Current ($V_{CE} = -30\text{ Vdc}$, $V_{BE(off)} = -0.5\text{ Vdc}$)		I_{CEX}	—	-50	nAdc
Collector Cutoff Current ($V_{CB} = -50\text{ Vdc}$, $I_E = 0$)	MMBT2907 MMBT2907A	I_{CBO}	— —	-0.020 -0.010	μAdc
($V_{CB} = -50\text{ Vdc}$, $I_E = 0$, $T_A = 125^\circ\text{C}$)	MMBT2907 MMBT2907A		— —	-20 -10	
Base Current ($V_{CE} = -30\text{ Vdc}$, $V_{EB(off)} = -0.5\text{ Vdc}$)		I_B	—	-50	nAdc

ON CHARACTERISTICS

DC Current Gain ($I_C = -0.1\text{ mAdc}$, $V_{CE} = -10\text{ Vdc}$)	MMBT2907 MMBT2907A	h_{FE}	35 75	— —	—
($I_C = -1.0\text{ mAdc}$, $V_{CE} = -10\text{ Vdc}$)	MMBT2907 MMBT2907A		50 100	— —	
($I_C = -10\text{ mAdc}$, $V_{CE} = -10\text{ Vdc}$)	MMBT2907 MMBT2907A		75 100	— —	
($I_C = -150\text{ mAdc}$, $V_{CE} = -10\text{ Vdc}$) (3)	MMBT2907 MMBT2907A		— 100	— 300	
($I_C = -500\text{ mAdc}$, $V_{CE} = -10\text{ Vdc}$) (3)	MMBT2907 MMBT2907A		30 50	— —	
Collector–Emitter Saturation Voltage (3) ($I_C = -150\text{ mAdc}$, $I_B = -15\text{ mAdc}$) ($I_C = -500\text{ mAdc}$, $I_B = -50\text{ mAdc}$)		$V_{CE(sat)}$	— —	-0.4 -1.6	Vdc
Base–Emitter Saturation Voltage (3) ($I_C = -150\text{ mAdc}$, $I_B = -15\text{ mAdc}$) ($I_C = -500\text{ mAdc}$, $I_B = -50\text{ mAdc}$)		$V_{BE(sat)}$	— —	-1.3 -2.6	Vdc

1.FR-5 = 1.0 X 0.75 X 0.062 in.

2.Alumina = 0.4 X 0.3 X 0.024 in. 99.5% alumina.

SMALL-SIGNAL CHARACTERISTICS

Current-Gain — Bandwidth Product (3),(4) ($I_C = -50 \text{ mAdc}$, $V_{CE} = -20 \text{ Vdc}$, $f = 100 \text{ MHz}$)	f_T	200	—	MHz
Output Capacitance ($V_{CB} = -10 \text{ Vdc}$, $I_E = 0$, $f = 1.0 \text{ MHz}$)	C_{obo}	—	8.0	pF
Input Capacitance ($V_{EB} = -2.0 \text{ Vdc}$, $I_C = 0$, $f = 1.0 \text{ MHz}$)	C_{ibo}	—	30	pF

SWITCHING CHARACTERISTICS

Turn-On Time	$(V_{CC} = -30 \text{ Vdc}$, $I_C = -150 \text{ mAdc}$, $I_{B1} = -15 \text{ mAdc}$)	t_{on}	—	45	ns
Delay Time		t_d	—	10	
Rise Time		t_r	—	40	
Turn-Off Time	$(V_{CC} = -6.0 \text{ Vdc}$, $I_C = -150 \text{ mAdc}$, $I_{B1} = I_{B2} = -15 \text{ mAdc}$)	t_{off}	—	100	ns
Storage Time		t_s	—	80	
Fall Time		t_f	—	30	

- Pulse Test: Pulse Width $\leq 300 \mu\text{s}$, Duty Cycle $\leq 2.0\%$.
- f_T is defined as the frequency at which $|h_{fe}|$ extrapolates to unity.

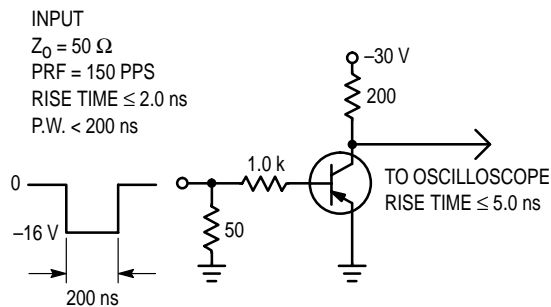

Figure 1. Delay and Rise Time Test Circuit

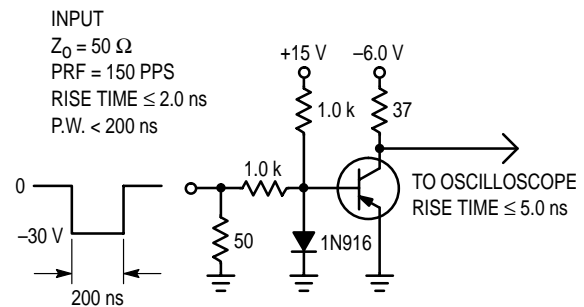

Figure 2. Storage and Fall Time Test Circuit

TYPICAL CHARACTERISTICS

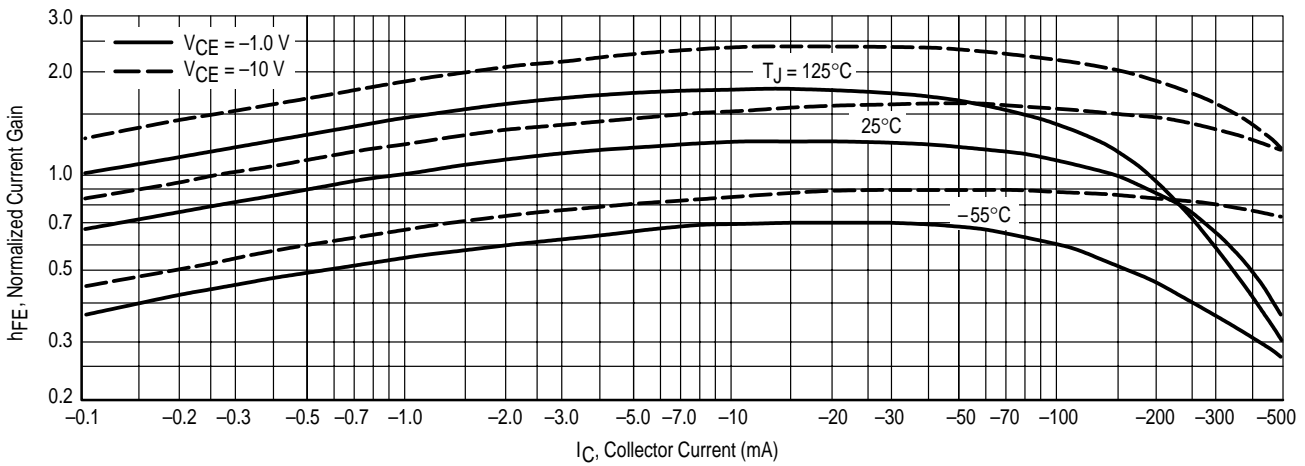

Figure 3. DC Current Gain

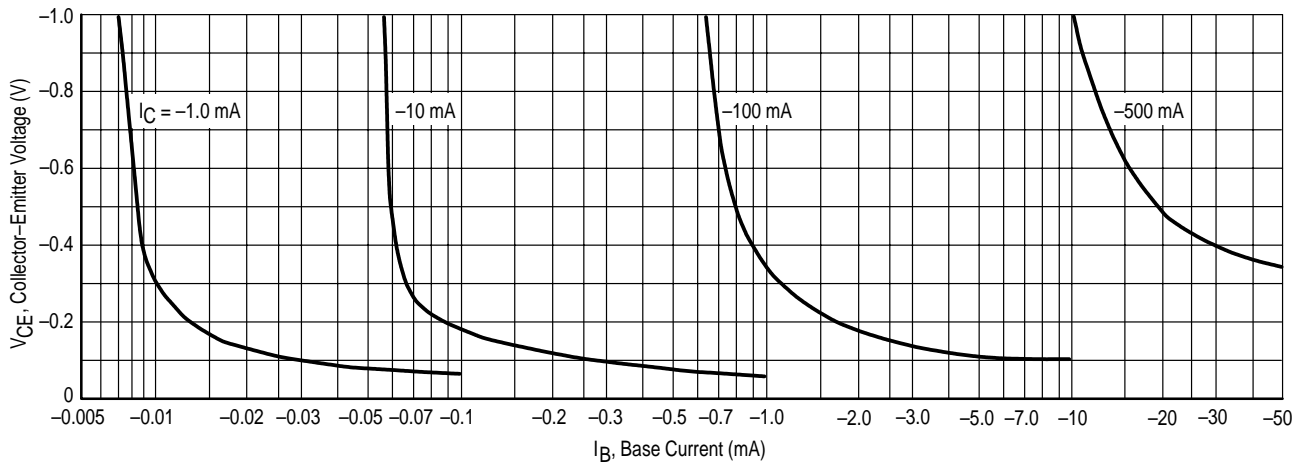

Figure 4. Collector Saturation Region

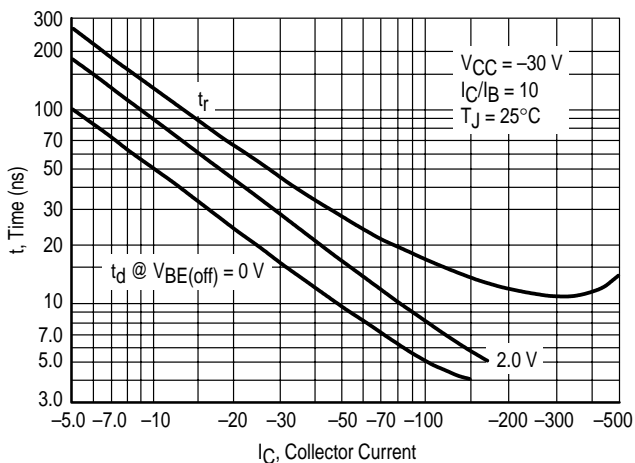

Figure 5. Turn-On Time

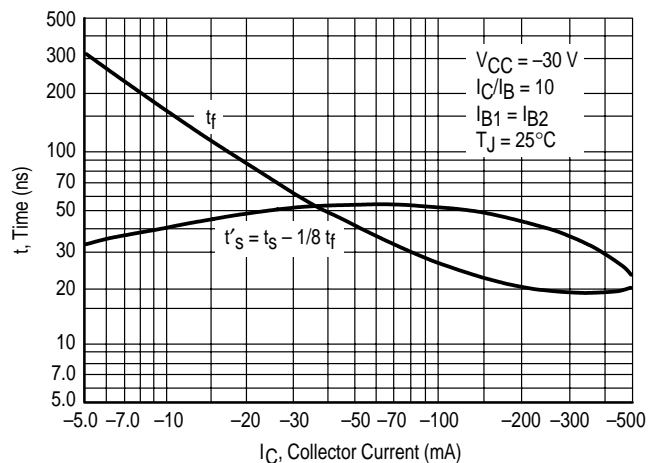

Figure 6. Turn-Off Time

TYPICAL SMALL-SIGNAL CHARACTERISTICS NOISE FIGURE

$V_{CE} = 10 \text{ Vdc}$, $T_A = 25^\circ\text{C}$

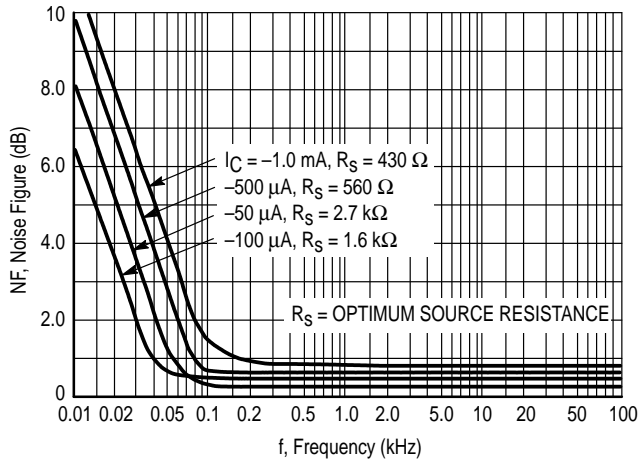

Figure 7. Frequency Effects

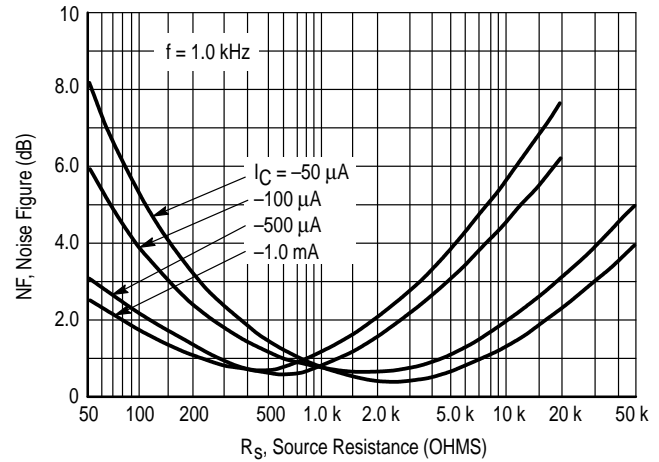

Figure 8. Source Resistance Effects

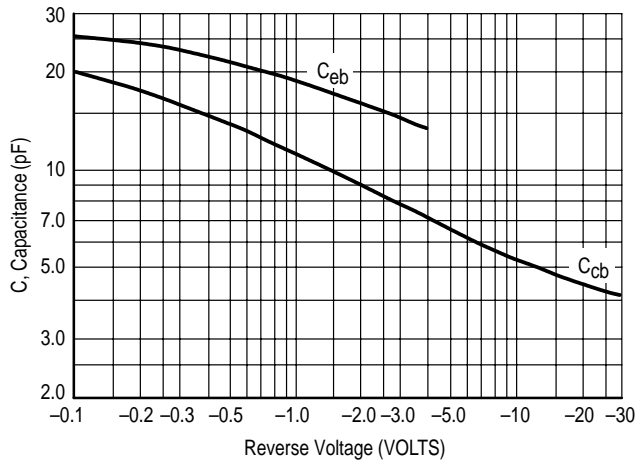

Figure 9. Capacitances

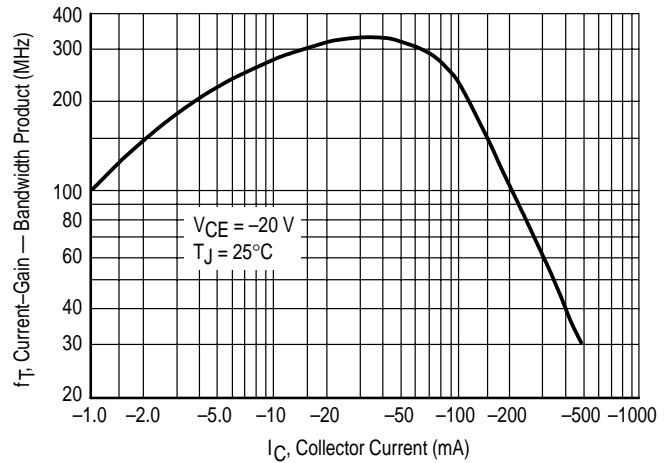

Figure 10. Current-Gain — Bandwidth Product

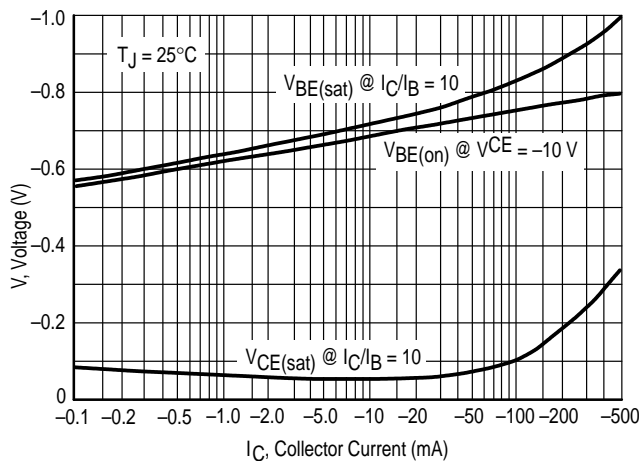

Figure 11. "On" Voltage

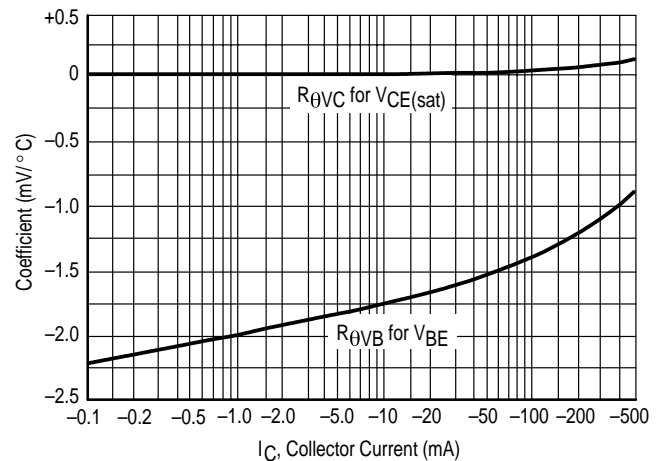

Figure 12. Temperature Coefficients