

03007

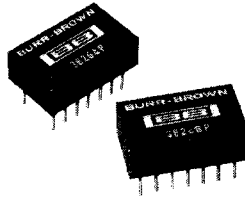

3626



## Low Drift INSTRUMENTATION AMPLIFIER

### FEATURES

- **LOW VOLTAGE DRIFT @ LOW GAIN**  
2 $\mu$ V/ $^{\circ}$ C @ G = 5 (3626CP)
- **LOW NOISE** - 2 $\mu$ V, p-p
- **HIGH CMR** - > 80dB @ G = 1000
- **LOW COST**
- **SMALL SIZE** - DIP Package

### DESCRIPTION

The 3626 is an integrated circuit instrumentation amplifier designed for amplifying low level signals in the presence of high common-mode voltages. Its low drift, high input impedance ( $5 \times 10^7 \Omega$ ), easy gain adjustment (5V V to 1000V V) and high common-mode rejection eliminate the problems and compromises associated with using operational amplifiers to realize the same gain function.

Compared to other integrated circuit instrumentation amplifiers it has the unique feature of having low voltage drift versus temperature at low gains.

The 3626 offers many benefits to the user for his instrumentation applications:

- Low voltage reduces temperature errors.
- High common-mode rejection preserves system accuracy.
- High input impedance prevents errors due to source loading and source impedance imbalance.
- Small, dual-in-line package conserves board space.
- Laser-trimmed offset requires no nulling.

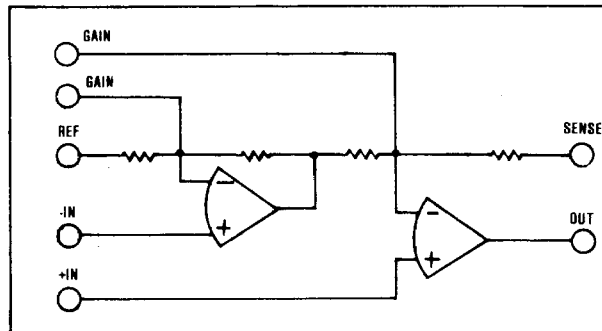

## DISCUSSION

An instrumentation amplifier is basically a closed-loop gain block that exhibits high input impedance and high common-mode rejection. Instrumentation amplifiers are committed devices with differential inputs and accurately predictable input-to-output relationships - all necessary feedback networks are contained in the circuit package. These characteristics distinguish instrumentation amplifiers from operational amplifiers - open-loop devices whose closed-loop performance depends upon the external networks supplied by the user.

In instrumentation amplifiers, parameters such as input and output impedances, frequency response, offset voltage drift, and common-mode rejection are specified for the closed-loop, committed configuration. One of the few parameters that the user can vary is gain (by choosing the external gain-setting resistor value). Another important difference between an operational amplifier and instrumentation amplifier is that the instrumentation amplifier has no summing junction available; you cannot make a summing amplifier or integrator out of an instrumentation amplifier.

In the past few years, choices in instrumentation amplifier designs have grown from a number of discrete modular units to include monolithic and hybrid integrated circuit versions which offer high performance at lower cost - and in smaller packages. Monolithic Integrated Circuits (IC's) were the first to break the price and performance barrier. Hybrid IC's, such as the 3626, are more expensive than monolithic IC's but they give better performance for the money.

Instrumentation amplifiers normally require at least one external resistor - the gain-setting resistor  $R_G$ . Monolithic units usually require two additional - the output feedback resistor and a resistor between feedback common and ground. Since temperature coefficient differences between these two resistors will cause output offset voltage drift, they must be matched to meet the desired drift specification. Hybrid units, such as the 3626, have the advantage that all resistors except the gain-setting  $R_G$ , can be included in the package.

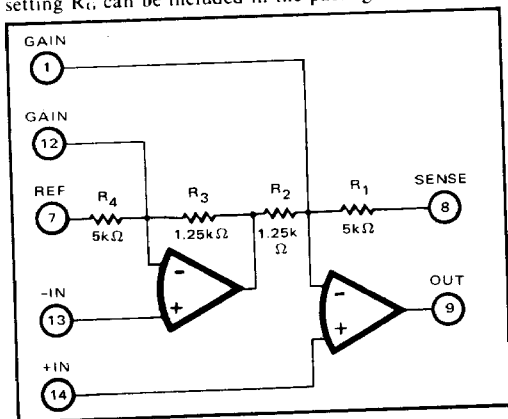

FIGURE 1. Simplified Circuit Diagram.

A simplified circuit diagram of the 3626 is shown in Figure 1. The circuit uses Burr-Brown's high performance bipolar integrated circuit amplifiers and a laser-trimmed thin-film resistor network. The excellent initial matching and temperature tracking of these components provide a level of performance difficult to obtain with even expensive discrete amplifiers and resistors. The gain accuracy, linearity, and temperature coefficient are particularly attractive.

One of the most outstanding features of the 3626 is its low voltage drift, especially at low and medium gains. Figure 2 shows the drift performance of the 3626 series compared to monolithic integrated circuit instrumentation amplifiers. The guaranteed voltage drift

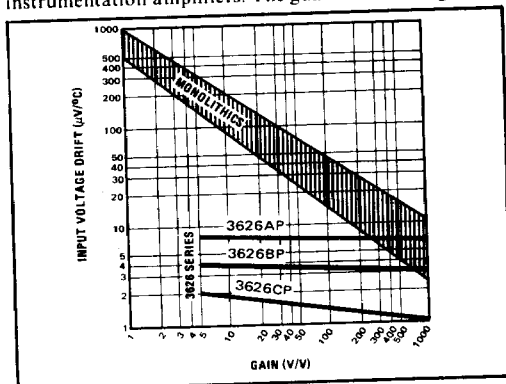

FIGURE 2. Input Offset Drift vs Gain.

performance is almost two orders of magnitude better at low gains.

The design of the 3626 is such that output biasing is easily accomplished. See Figure 3 for proper connections. The impedance of the reference source should be low compared to  $5k\Omega$ . A current booster such as the 3329 (100mA) or 3553 (200mA) can conveniently be used with the 3626 to increase its output current driving capability.

An application note, "Instrumentation Amplifiers" (AN-75) is available which has information on the use of instrumentation amplifiers. Contact your nearest sales office or our factory in Tucson to obtain a copy.

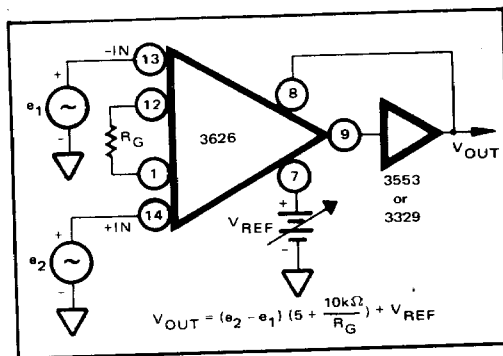

FIGURE 3. Output Offsetting and Power Boosting.

# SPECIFICATIONS

<b>ELECTRICAL</b>			
Specifications typical at 25°C and ±15VDC unless otherwise noted.			
MODELS	3626AP	3626BP	3626CP
<b>GAIN</b>			
Gain Equation	$G = 5 + (10k\Omega/R_G)$		
Error from Equation(1)	±0.25 - 0.003G %		
Range of Gain, min	5 to 1000		
Gain Temp. Coefficient:			
G = 5	2ppm/°C		
G = 10	25ppm/°C		
G = 100	35ppm/°C		
G = 1000	50ppm/°C		
Nonlinearity, max (%)(2)	±(0.02 + 0.0003G)	±(0.01 + 0.0003G)	±(0.01 + 0.0003G)
<b>OUTPUT</b>			
Rated Output, min	±10V @ ±5mA		
Output Impedance, G = 100	2Ω		
<b>INPUT</b>			
Input Impedance, Diff. & CM	5 x 10 <sup>9</sup> Ω    3pF		
Input Voltage Range, min	±10V		
CMR, DC to 60Hz	with 1kΩ source unbalance		
G = 5, min	68dB	74dB	74dB
G = 10 to 1000, min	74dB	80dB	80dB
<b>INPUT OFFSET VOLTAGE</b>			
Initial Offset, max(1)	± 0.4 + (0.4/G) mV	± 0.2 + (0.2/G) mV	± 0.2 + (0.2/G) mV
vs. Temperature, max vs. Supply vs. Time	± 6 + (10/G) μV/°C	± 3 + (5/G) μV/°C 40μV/V	± 1 + (5/G) μV/°C 3μV/mo
<b>INPUT BIAS CURRENTS</b>			
Initial Bias Current, max vs. Temperature, max vs. Supply	±50nA either input ±0.7nA/°C ±0.1nA/V		
<b>INPUT NOISE</b>			
Voltage, p-p, 0.01Hz to 10Hz rms, 10Hz to 10kHz	2μV, p-p 2μV, rms		
Current, p-p, 0.01Hz to 10Hz rms, 10Hz to 10kHz	150pA, p-p 50pA, rms		
<b>DYNAMIC RESPONSE</b>			
Small Signal, ±3dB Flatness:			
G = 5	400kHz		
G = 10	160kHz		
G = 100	14kHz		
G = 1000	1.4kHz		
Small Signal, ±1% Flatness:			
G = 5	76kHz		
G = 10	27kHz		
G = 100	2.1kHz		
G = 1000	250Hz		
Full Power, G = 5 to 100	19kHz		
Slew Rate, G = 5 to 100	1.2V/μsec		
Settling Time (0.1%):			
G = 5	20μsec		
G = 10	30μsec		
G = 100	100μsec		
G = 1000	12ms		
<b>POWER SUPPLY</b>			
Rated Voltage	±15VDC		
Voltage Range	±5VDC to ±20VDC		
Quiescent Supply Current	±7mA, max		
<b>TEMPERATURE RANGE</b>			
Specifications, min Operation Storage	-25°C to +85°C -55°C to +125°C -65°C to +150°C		

### NOTES:

- May be trimmed to zero.
- Nonlinearity is the maximum peak deviation from the best straightline as a percent of full scale peak-to-peak output.

# MECHANICAL

### NOTE

Leads in true position within 010° (±25mm) R @ MMC at seating plane.

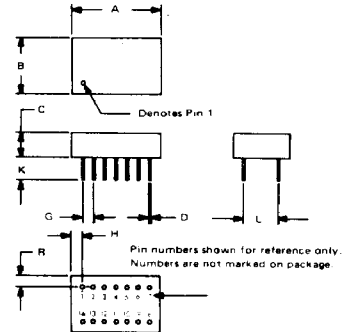

DIM	INCHES		MILLIMETERS	
	MIN	MAX	MIN	MAX
A	.790	.810	20.07	20.57
B	.490	.510	12.45	12.95
C	.190	.260	4.83	6.60
D	.018	.021	0.46	0.53
G	100 BASIC		2.54 BASIC	
H	.080	.115	2.03	2.92
K	.130	.300	3.30	7.62
L	300 BASIC		7.62 BASIC	
R	.080	.115	2.03	2.92

Row Spacing: 7.6mm (0.300")

Weight: 3.4 grams (0.12 oz.)

Connector: 0145MC - 14-pin DIP

Pin material and plating composition conform to Method 2003 solderability of MIL-STD-883.

# PIN CONNECTIONS

- |                            |          |
|----------------------------|----------|
| 1. GAIN                    | 12. GAIN |
| 2. NO INTERNAL CONNECTION  | 13. -IN  |
| 3. CONNECTION              | 14. +IN  |
| 4. Vos                     |          |
| 5. Vos                     |          |
| 6. -Vcc                    |          |
| 7. REF                     |          |
| 8. SENSE                   |          |
| 9. OUT                     |          |
| 10. +Vcc                   |          |
| 11. NO INTERNAL CONNECTION |          |

# CONNECTION DIAGRAM

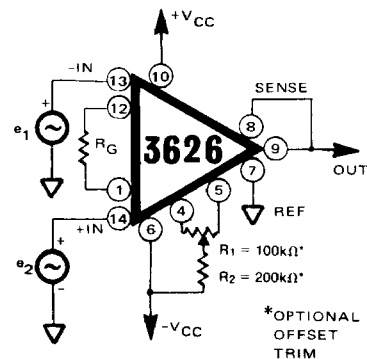

# TYPICAL PERFORMANCE CURVES

Typical @ 25°C and ±15VDC power supplies unless otherwise noted.

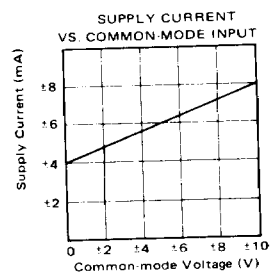
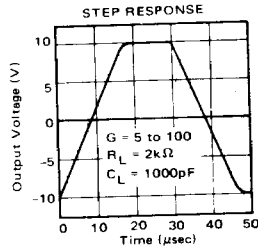
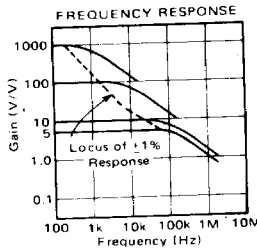
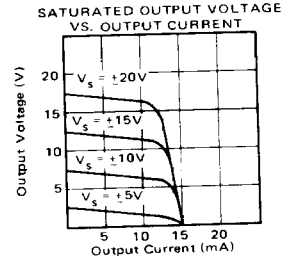
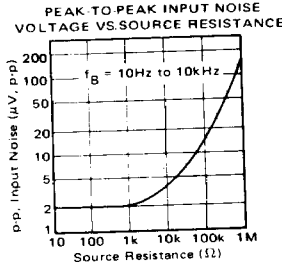
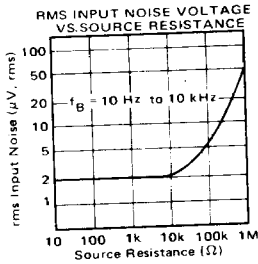
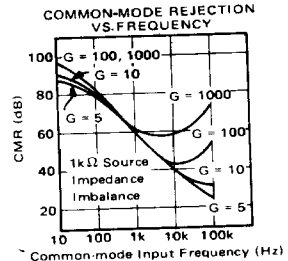
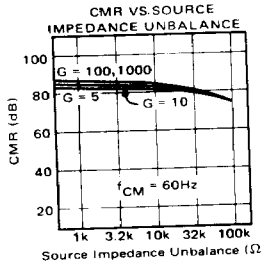
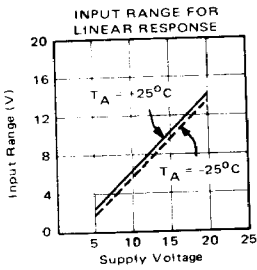

## INSTALLATION AND OPERATING INSTRUCTIONS

### SETTING THE GAIN

Figure 3 shows the normal operating connections for the 3626. The differential gain,  $G$ , is determined according to the equation:

$$G = 5 + \frac{10\text{k}\Omega}{R_G}$$

where  $R_G$  is the resistor shown in Figure 4. This gain equation is typically accurate to 0.25%. The temperature coefficient of  $R_G$  will directly affect the stability of  $G$ . For high gains,  $R_G$  will be quite small ( $R_G = 10\Omega$  for  $G = 1000$ ); thus, the wiring impedance between pins 12 and 1 should be kept as low as possible. (Trimming of  $R_G$  will eliminate the effects of wiring impedances so long as this impedance is constant.) Also, note that  $V_{ref}$  source needs to be low impedance so as not to significantly affect the gain equation.

### COMMON-MODE REJECTION TRIM

The 3626 meets its CMR specifications without additional trimming; however, for improved CMR in special situations (such as imbalanced source

impedances), the circuit in Figure 4 may be used. In this circuit,  $R_1$  is added to intentionally imbalance the inverting and noninverting gains of the amplifier.  $R_2$  is then used to rebalance them, which overcomes the effects of any residual CMR degradation due to source impedance imbalance, etc. An improvement of approximately 6 to 10dB can be typically realized at low gains.

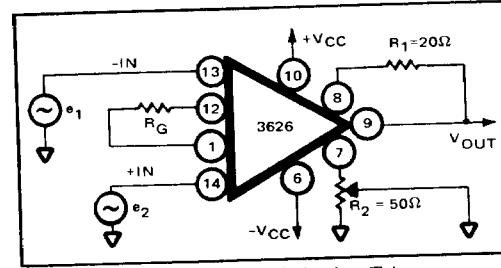

FIGURE 4. Common-mode Rejection Trim.