

MPC801

High Speed CMOS ANALOG MULTIPLEXER

FEATURES

- **HIGH SPEED**
80ns Access Time
800ns Settling to 0.01%
250ns Settling to 0.1%
- **USER-PROGRAMMABLE**
8-Channel Single-Ended or
4-Channel Differential
- **SELECTABLE TTL OR CMOS
COMPATIBILITY**
- **WILL NOT SHORT SIGNAL SOURCES —
Break-Before-Make Switching**
- **SELF-CONTAINED WITH INTERNAL
CHANNEL ADDRESS DECODER**
- **18-PIN HERMETIC DUAL-IN-LINE
PACKAGE**

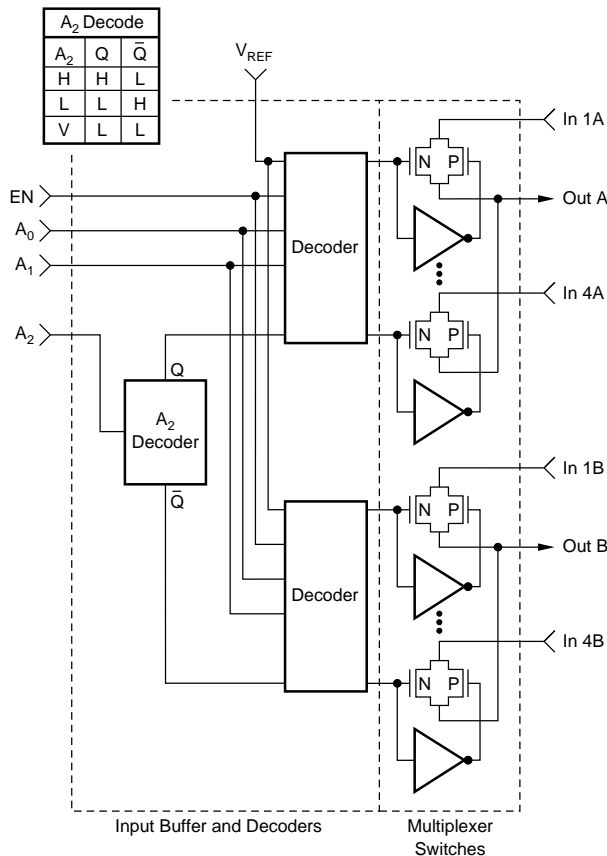

DESCRIPTION

The MPC801 is a high speed multiplexer that is user-programmable for 8-channel single-ended operation or 4-channel differential operation and for TTL or CMOS compatibility.

The MPC801 features a self-contained binary address decoder. It also has an enable line which allows the user to inhibit the entire multiplexer thereby facilitating channel expansion by adding additional multiplexers.

High quality processing is employed to produce CMOS FET analog channel switches which have low leakage current, low ON resistance, high OFF resistance, low feedthrough capacitance, and fast settling time.

Two models are available, the MPC801KG for operation from 0°C to +75°C.

SPECIFICATIONS

ELECTRICAL

At $T_A = +25^\circ\text{C}$ and $\pm V_{CC} = 15\text{V}$, unless otherwise noted.

PARAMETER	MPC801KG			UNITS
	MIN	TYP	MAX	
ANALOG INPUTS				
Voltage Range	-15		+15	V
Maximum Overvoltage	$-V_{CC} - 2$		$+V_{CC} + 2$	V
Number of Input Channels				
Differential	4			
Single-Ended	8			
Reference Voltage Range ⁽¹⁾	6		10	V
ON Characteristics ⁽²⁾				
ON Resistance (R_{ON}) at $+25^\circ\text{C}$		500	750	Ω
Over Temperature Range		700	1000	Ω
R_{ON} Drift vs Temperature		See Typical Performance Curves		
R_{ON} Mismatch		< 10		Ω
ON Channel Leakage		0.1		nA
Over Temperature Range		0.3	50	nA
ON Channel Leakage Drift		See Typical Performance Curves		
OFF Characteristics				
OFF Isolation		90		dB
OFF Channel Input Leakage		0.05		nA
Over Temperature Range		0.6	50	nA
OFF Channel Input Leakage Drift		See Typical Performance Curves		
OFF Channel Output Leakage		0.1		nA
Over Temperature Range		0.30	50	nA
OFF Channel Output Leakage Drift		See Typical Performance Curves		
Output Leakage (All channels disabled) ⁽³⁾		0.02		nA
Output Leakage with Overvoltage				
+16V Input		< 0.35		mA
-16V Input		< 0.65		mA
DIGITAL INPUTS				
Over Temperature Range				
TTL ⁽⁴⁾				
Logic "0" (V_{AL})			0.8	V
Logic "1" (V_{AH})	2.4			V
I_{AH}		0.05	1	μA
I_{AL}		4	20	μA
TTL Input Overvoltage	-6		6	V
CMOS				
Logic "0" (V_{AL})			$0.3V_{REF}$	V
Logic "1" (V_{AH})	$0.7V_{REF}$			V
CMOS Input Overvoltage	-2		$+V_{CC} + 2$	V
Address A_2 Overvoltage	$-V_{CC} - 2$		$+V_{CC} + 2$	V
Digital Input Capacitance		5		pF
Channel Select ⁽⁵⁾				
Single-Ended		3-bit Binary Code One of 8		
Differential		2-bit Binary Code One of 4		
Enable		Logic "0" Inhibits All Channels		
POWER REQUIREMENTS				
Over Temperature Range				
Rated Supply Voltage		± 15		V
Maximum Voltage Between Supply Pins			33	V
Total Power Dissipation		360		mW
Allowable Total Power Dissipation ⁽⁶⁾			725	mW
Supply Drain ($+25^\circ\text{C}$)				
At 1MHz Switching Speed		+14, -12.5		mA
At 100kHz Switching Speed		+12.5, -12.5		mA

The information provided herein is believed to be reliable; however, BURR-BROWN assumes no responsibility for inaccuracies or omissions. BURR-BROWN assumes no responsibility for the use of this information, and all use of such information shall be entirely at the user's own risk. Prices and specifications are subject to change without notice. No patent rights or licenses to any of the circuits described herein are implied or granted to any third party. BURR-BROWN does not authorize or warrant any BURR-BROWN product for use in life support devices and/or systems.



SPECIFICATIONS (CONT)

ELECTRICAL

At $T_A = +25^\circ\text{C}$ and $\pm V_{CC} = 15\text{V}$, unless otherwise noted.

PARAMETER	MPC801KG			UNITS
	MIN	TYP	MAX	
DYNAMIC CHARACTERISTICS				
Gain Error		< 0.0003		%
Crosstalk ⁽⁷⁾		See Typical Performance Curves		
T_{OPEN} (Break-before-make delay)		20		ns
Access Time at $+25^\circ\text{C}$		80	125	ns
Over Temperature Range		110	150	ns
Settling Time ⁽⁸⁾				
to 0.1% (20mV)		250		ns
to 0.01% (2mV)		800		ns
Common-Mode Rejection (Differential)				
DC		> 125		dB
60Hz		> 75		dB
OFF Channel Input Capacitance, C_S		1.9		pF
OFF Channel Output Capacitance, C_O		10		pF
OFF Input to Output Capacitance, C_{DS}		0.02		pF
TEMPERATURE				
MPC800KG				
Specification	0		+75	$^\circ\text{C}$
Storage	-65		+150	$^\circ\text{C}$

NOTES: (1) Reference voltage controls noise immunity, normally left open for TTL compatibility and connected to V_{DD} for CMOS compatibility. (2) $V_{IN} = \pm 10\text{V}$, $I_{OUT} = 100\mu\text{A}$. (3) Single-ended mode. (4) Logic levels specified for V_{REF} (pin 8) open. (5) For single-ended operation, connect output A (pin 18) to output B (pin 2) and use A_2 (pin 9) as an address line. For differential operation connect A_2 to $-V_{CC}$. (6) Derate $8\text{mW}/^\circ\text{C}$ above $T_A = +75^\circ\text{C}$. (7) 10Vp-p sine wave on all unused channels. See Typical Performance Curves. (8) For 20V step input to ON channel, into $1\text{k}\Omega$ load.

PIN CONFIGURATION

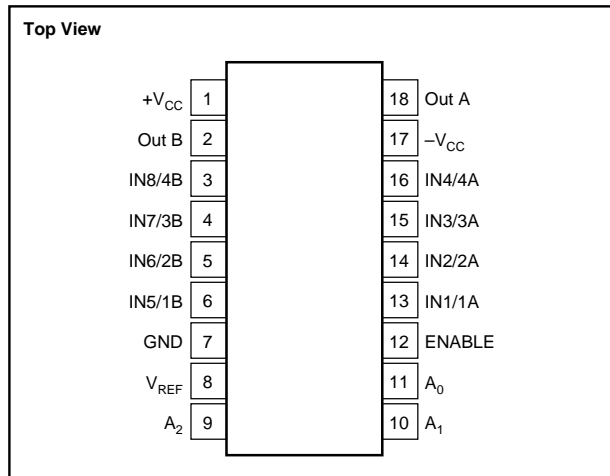

ORDERING INFORMATION

MODEL	PACKAGE	TEMPERATURE RANGE
MPC801KG	Cerdip	0°C to $+75^\circ\text{C}$

PACKAGE INFORMATION

MODEL	PACKAGE	PACKAGE DRAWING NUMBER ⁽¹⁾
MPC801KG	18-Pin Single-Wide Cerdip	266

NOTE: (1) For detailed drawing and dimension table, please see end of data sheet, or Appendix D of Burr-Brown IC Data Book.

TYPICAL PERFORMANCE CURVES

At $T_A = +25^\circ\text{C}$ and $\pm V_{CC} = 15\text{V}$, unless otherwise noted.

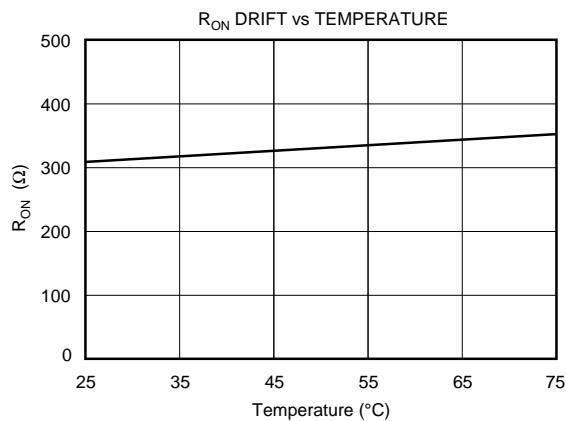
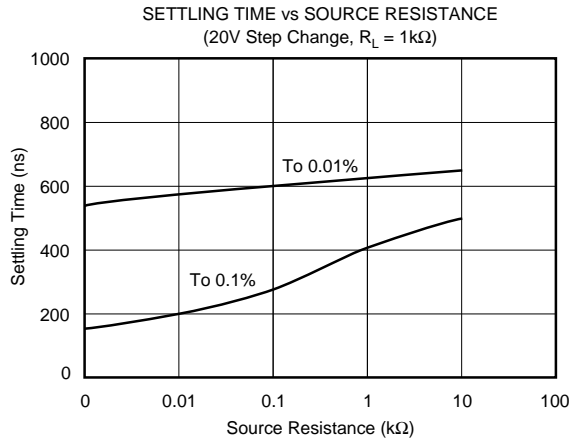
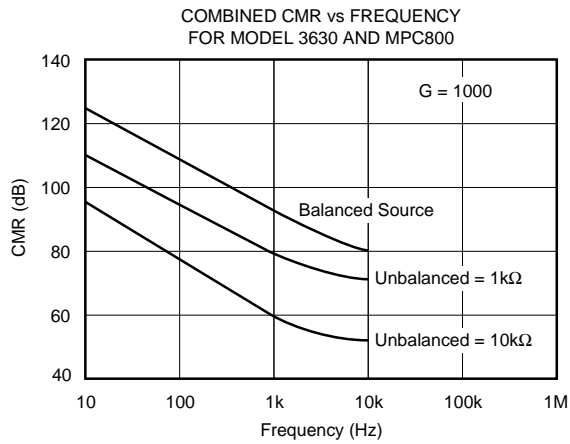
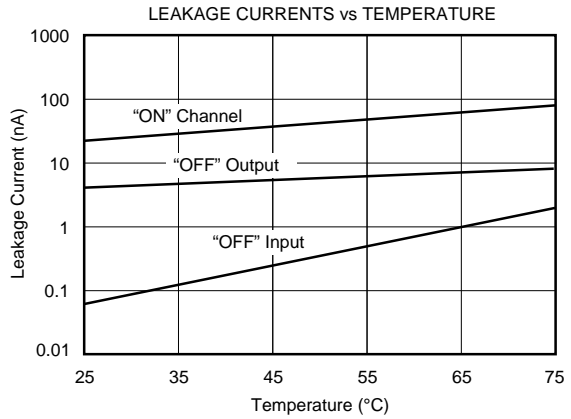
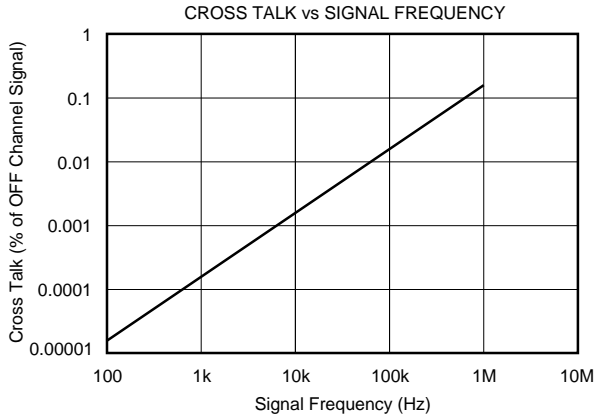

DISCUSSION OF PERFORMANCE

STATIC TRANSFER ACCURACY

The static or DC transfer accuracy of transmitting the multiplexer input voltage to the output depends on the channel ON resistance (R_{ON}), the load impedance, the source impedance, the load bias current, and the multiplexer leakage current.

Single-Ended Multiplexer Static Accuracy

The major contributors to static transfer accuracy for single-ended multiplexers are:

- Source resistance loading error
- Multiplexer ON resistance error
- DC offset error caused by both load bias current and multiplexer leakage current.

Resistive Loading Errors

The source and load impedances will determine the ON resistance loading errors. To minimize these errors:

- *Keep loading impedance as high as possible.* This minimizes the resistive loading effects of the source resistance and multiplexer ON resistance. As a guideline, load impedance of $10^8\Omega$ or greater will keep resistive loading errors to 0.002% or less for 1000Ω source impedances. A $10^6\Omega$ load impedance will increase source loading error to 0.2% or more.
- *Use sources with impedances as low as possible.* A 1000Ω source resistance will present less than 0.002% loading error and $10k\Omega$ source resistance will increase source loading error 0.02% with a $10^8\Omega$ load impedance.

Input resistive loading errors are determined by the following relationship (see Figure 1):

Source and Multiplexer Resistive Loading Error

$$\epsilon = (R_S + R_{ON}) = \frac{R_S + R_{ON}}{R_S + R_{ON} + R_L} \times 100\%$$

- where, $R_S = R_{SOURCE}$
 $R_L =$ Load resistance
 $R_{OS} =$ Multiplexer ON resistance

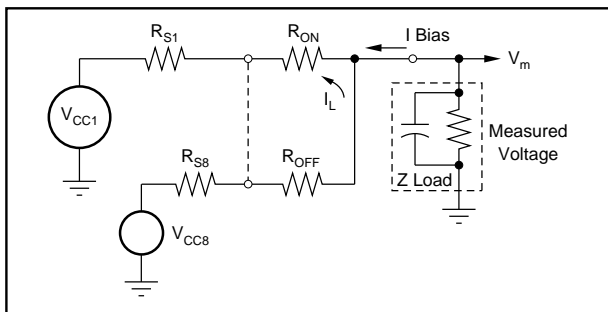

FIGURE 1. MPC801 Static Accuracy Equivalent Circuit (Single-ended Operation).

Input Offset Voltage

Bias and leakage currents generate an input offset voltage as a result of the voltage drop across the multiplexer ON resistance and source resistance. A load bias current of $10nA$, a leakage current of $1nA$, and an ON resistance of 700Ω will generate an offset voltage of $19\mu V$ if a 1000Ω source is used, and $118\mu V$ if a $10k\Omega$ source is used. In general, for the MPC801 the offset voltage at the output is determined by:

$$V_{OFFSET} = (I_B + I_L) (R_{ON} + R_{SOURCE})$$

where:

- $I_B =$ Bias current of device multiplexer is driving
- $I_L =$ Multiplexer leakage current
- $R_{ON} =$ Multiplexer ON resistance
- $R_{SOURCE} =$ Source resistance

Differential Multiplexer Static Accuracy

Static accuracy errors in a differential multiplexer are difficult to control, especially when it is used for multiplexing low level signals with full scale ranges of $10mV$ to $100mV$.

The matching properties of the multiplexer, source and output load play a very important part in determining the transfer accuracy of the multiplexer. The source impedance unbalance, common-mode impedance, load bias current mismatch, load differential impedance mismatch, and common-mode impedance of the load all contribute errors to the multiplexer. The multiplexer ON resistance mismatch, leakage current mismatch and ON resistance also contribute to differential errors.

Referring to Figure 2, the effects of these errors can be minimized by following the general guidelines described in this section, especially for low level multiplexing applications.

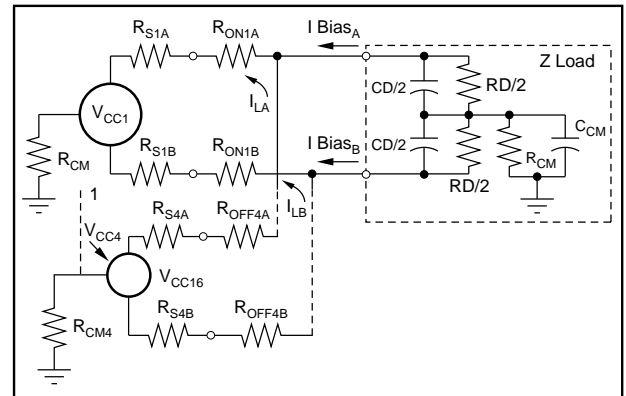

FIGURE 2. MPC801 Static Accuracy Equivalent Circuit (Differential Operation).

Load (Output Device) Characteristics

- *Use devices with very low bias current.* Generally, FET input amplifiers should be used for low level signals less than $50mV$ FSR. Low bias current bipolar input amplifiers are acceptable for signal ranges higher than $50mV$ FSR. Bias current matching will determine input offset.

- The system DC common-mode rejection (CMR) can never be better than the combined CMR of multiplexer and driven load. System CMR will be less than the device which has the lower CMR figure.
- Load impedances, differential and common-mode should be $10^{10}\Omega$ or higher.

Source Characteristics

- The source impedance unbalance will produce offset, common-mode and channel-to-channel gain scatter errors. Use sources which do not have large impedance unbalances if at all possible.
- Keep source impedances as low as possible to minimize resistive loading errors.
- Minimize ground loops. If signal lines are shielded, ground all shields to a common point at the system analog common.

If the MPC801 is used for multiplexing high level signals of 1V to 10V full scale ranges, the foregoing precautions should be taken, but the parameters are not as critical as for low level signal applications.

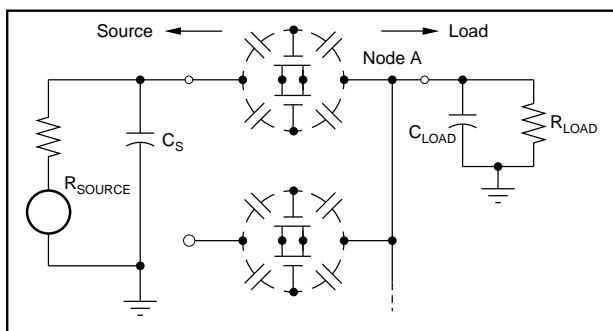

FIGURE 3. Settling Time Effects (Single-ended).

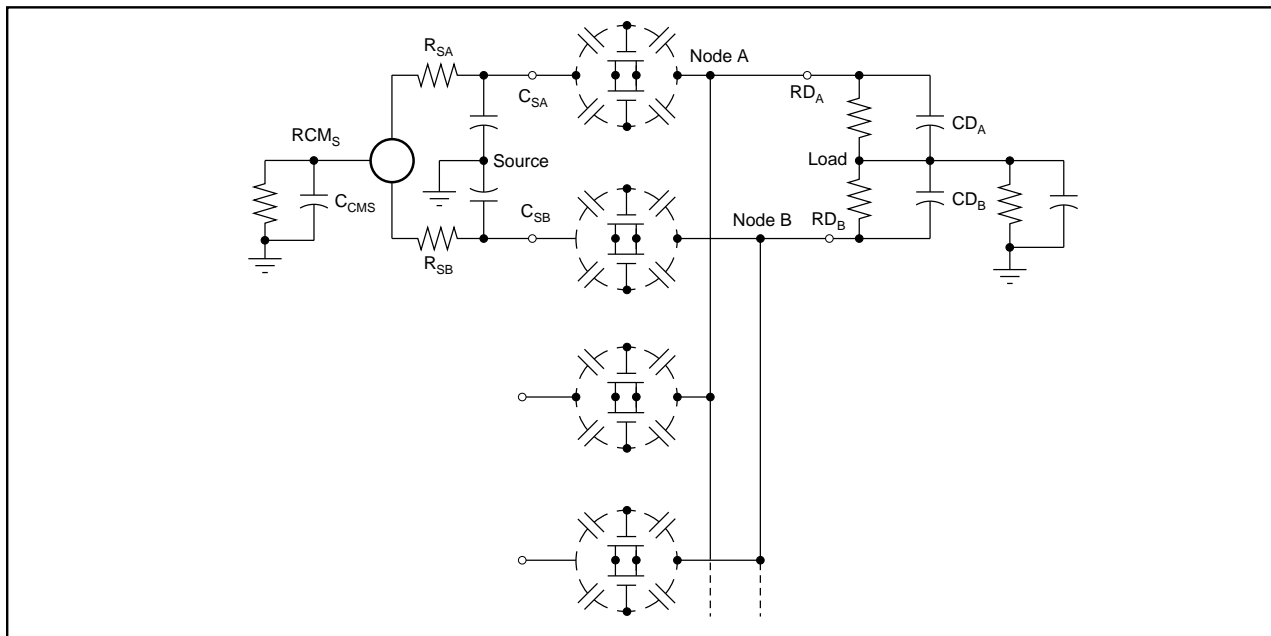

FIGURE 4. Settling and Common-Mode Effects (Differential).

SETTLING TIME

Settling time is the time required for the multiplexer to reach and maintain an output within a specified error band of its final value in response to a step input. The settling time of the MPC801 is primarily due to the channel capacitance and a combination of resistances which include the source and load resistances.

If the parallel combination of the source and load resistance times the total channel capacitance is kept small, then the settling time is primarily affected by internal RCs. For the MPC801, the internal capacitance is approximately 10pF differential or 20pF single-ended. With external capacitance neglected, the time constant of source resistance in parallel with load resistance and the internal capacitance should be kept less than 40ns. This means the source resistance should be kept to less than 4kΩ (assume high load resistance) to maintain fast settling times.

ACCESS TIME

This is the time required for the CMOS FET to turn ON after a new digital code has been applied to the Channel Address inputs. It is measured from the 50 percent point of the address input signal to the 90 percent point of the analog signal seen at the output for a 10V signal change between channels.

CROSSTALK

Crosstalk is the amount of signal feedthrough from the 3 differential or 7 signal-ended OFF channels appearing at the multiplexer output. Crosstalk is caused by the voltage divider effect of the OFF channel. OFF resistance, and junction capacitances in series with the R_{ON} and R_{SOURCE} impedances of the ON channel. Crosstalk is measured with

a 20Vp-p, 1000Hz sine wave applied to all OFF channels. The crosstalk for these multiplexers is shown in the Typical Performance Curves.

COMMON-MODE REJECTION (Differential Mode Only)

The matching properties of the load, multiplexer and source affect the common-mode rejection (CMR) capability of a differentially multiplexed system. CMR is the ability of the multiplexer and input amplifier to reject signals that are common to both inputs, and to pass on only the signal difference to the output. Protection is provided for common-mode signals of $\pm 2V$ above the power supply voltages with no damage to the analog switches.

The CMR of the MPC801 and Burr-Brown's model 3630 instrumentation amplifier is 120dB at DC to 10Hz with a 6dB/octave rolloff to 80dB at 1000Hz. This measurement of CMR is shown in the Typical Performance Curves and is made with a Burr-Brown model 3630 instrumentation amplifier connected for a gain of 1000 and with source unbalance of 10k Ω , 1k Ω and no unbalance.

Factors which will degrade multiplexer and system DC CMR are:

- Amplifier bias current and differential impedance mismatch.
- Load impedance mismatch.
- Multiplexer impedance and leakage current mismatch.
- Load and source common-mode impedance.

AC CMR rolloff is determined by the amount of common-mode capacitances (absolute and mismatch) from each signal line to ground. Larger capacitances will limit CMR at higher frequencies; thus, if good CMR is desired at higher frequencies, the common-mode capacitances and unbalance of signal lines and multiplexer to amplifier wiring must be minimized. Use twisted-shielded pair signal lines wherever possible.

INSTALLATION AND OPERATING INSTRUCTIONS

The ENABLE input, pin 12, is included for expansion of the number of channels on a single-node as illustrated in Figure 5. With the ENABLE line at a logic 1, the channel is selected by the Channel Select Address (shown in the Truth Tables). If ENABLE is at logic 0, all channels are turned OFF, even if the Channel Address Lines are active. If the ENABLE line is not to be used, simply tie it to logic 1.

For the best settling time, the input wiring and interconnections between multiplexer output and driven devices should be kept as short as possible. When driving the digital inputs from TTL, open collector output with pullup resistors are recommended.

To preserve common-mode rejection of the MPC801, use twisted-shielded pair wire for signal lines and inter-tier connections and/or multiplexer output lines. This will help

common-mode capacitance balance and reduce stray signal pickup. If shields are used, all shields should be connected as close as possible to system analog common or to the common-mode guard driver.

LOGIC LEVELS

The logic level is user-programmable as either TTL-compatible by leaving the V_{REF} (pin 8) open, or CMOS-compatible by connecting the V_{REF} to V_{DD} (CMOS supply voltage).

16-CHANNEL SINGLE-ENDED OPERATION

To use the MPC801 as a 8-channel single-ended multiplexer, output A (pin 18) is connected to output B (pin 2) to form a single output, then all three address lines (A_0 , A_1 and A_2) are used to address the correct channel.

The MPC801 can also be used as a dual channel single-ended multiplexer by not connecting output A and B, but then only one channel in one of the multiplexers can be addressed at a time.

8-CHANNEL DIFFERENTIAL OPERATION

To use the MPC801 as an 4-channel differential multiplexer, connect address line A_2 to $-V_{CC}$ then use the remaining two address lines (A_0 , and A_1) to address the correct channel. The differential inputs are the pairs of A_1 and B_1 , A_2 and B_2 , etc.

TRUTH TABLES

MPC801 used as an 8-channel single-ended multiplexer or 4-channel dual multiplexer.

USE A_2 AS DIGITAL ADDRESS INPUT				"ON" CHANNEL TO	
ENABLE	A_2	A_1	A_0	OUT A	OUT B
L	X	X	X	None	None
H	L	L	L	1A	None
H	L	L	H	2A	None
H	L	H	L	3A	None
H	L	H	H	4A	None
H	H	L	L	None	1B
H	H	L	H	None	2B
H	H	H	L	None	3B
H	H	H	H	None	4B

For 8-channel single-ended function, tie "out A" to "out B", for dual 4-channel function use the A_2 address pin to select between MUX A and MUX B, where MUX A is selected with A_2 low.

MPC801 used as a 4-channel differential multiplexer.

A_2 CONNECT TO $-V_{CC}$			"ON" CHANNEL TO	
ENABLE	A_1	A_0	OUT A	OUT B
L	X	X	None	None
H	L	L	1A	1B
H	L	H	2A	2B
H	H	L	3A	3B
H	H	H	4A	4B

CHANNEL EXPANSION

Single-Tier Expansion

Up to eight MPC801s can be connected to a single node to form a 64-channel single-ended multiplexer, or up to eight MPC801s can be connected to two nodes to form a 32-channel differential multiplexer. Programming is accomplished with a 6-bit address and a 1-of-8 decoder (see Figure 5). The decoder drives the enable inputs of the MPC801 turning on only one multiplexer at a time.

Two-Tier Expansion

Up to nine MPC801s can be connected in a two-tier structure to form a 64-channel single-ended multiplexer (see Figure

6), or up to five MPC801s can be connected in a two-tier structure to form a 16-channel differential multiplexer. Programming is accomplished with a 6-bit address.

SINGLE VS MULTITIERED CHANNEL EXPANSION

In addition to reducing programming complexity, two-tier configuration offers the added advantages over single-node expansion of reduced OFF channel current leakage (reduced Offset), better CMR, and a more reliable configuration if a channel should fail in the ON condition (short). Should a channel fail ON in the single-node configuration, data cannot be taken from any channel, whereas only one-channel group is failed (4 or 8) in the multitiered configuration.

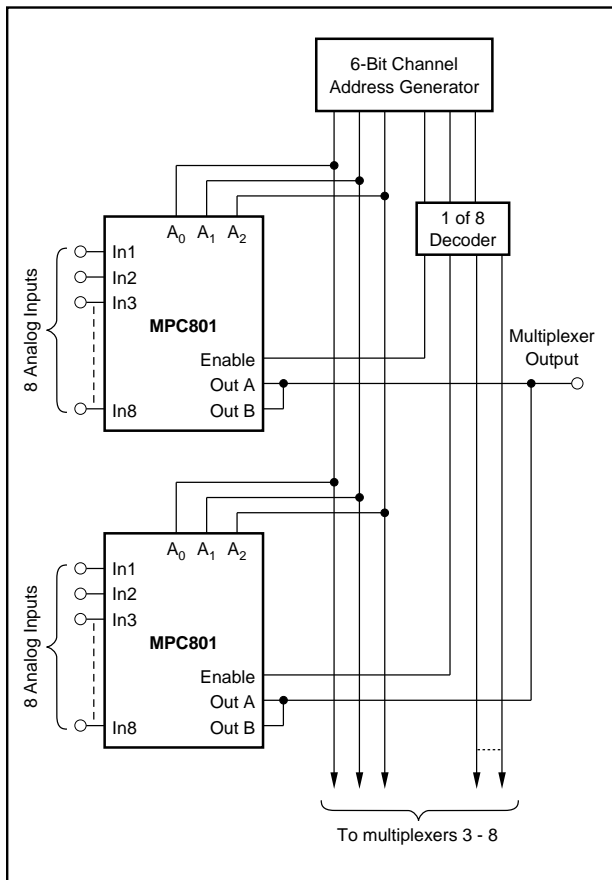

FIGURE 5. 64-channel, Single-tier, Single-ended Expansion.

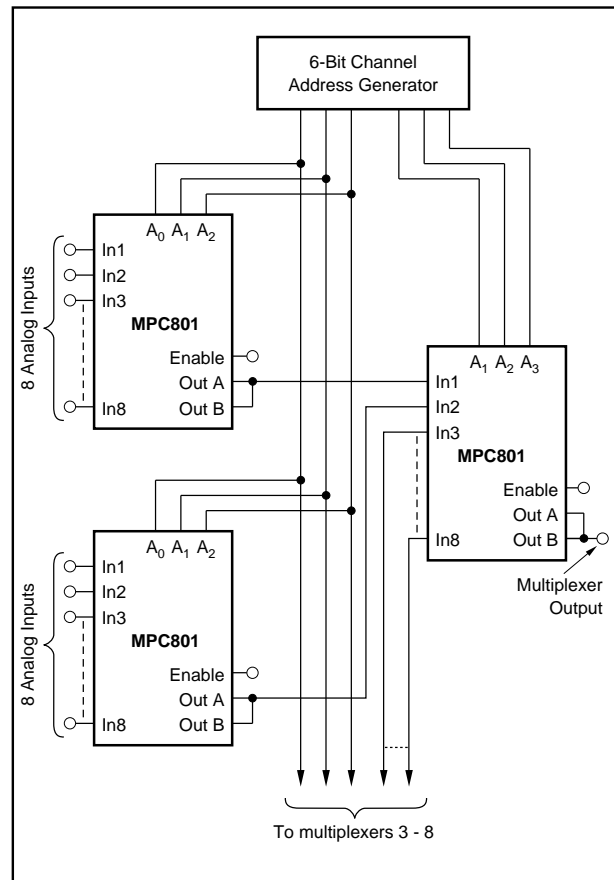

FIGURE 6. 64-channel, Two-tier, Single-ended Expansion.