

## DESCRIPTION

The DEM-OPA68xU demonstration board is an unpopulated printed circuit board (PCB) for Burr-Brown's high speed single op amps available in SO-8 packages. Figure 1 shows the pin out used for most of these op amps. Table I lists the exceptions to this pin-out that are also supported by this board. For more information on these op amps, and good PCB layout techniques, see the individual data sheets.

The ordering number for this board is MKT-351. Limit of 5 per customer.

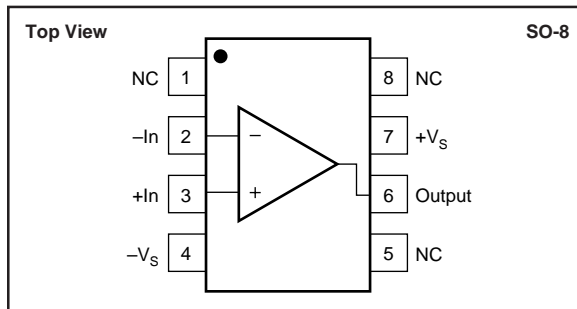

FIGURE 1. Pin Configuration for OPA6xxU.

PRODUCT	PIN #2	PIN #5	PIN #8
OPA63xU	—	—	DIS
OPA64xU	—	-V <sub>S</sub> (optional)	+V <sub>S</sub> (optional)
OPA628U	—	-V <sub>S</sub>	+V <sub>S</sub>
OPA680U	—	—	DIS
OPA681U	—	—	DIS
OPA682U	R <sub>G</sub>	—	DIS
OPA686U	—	—	DNC <sup>(1)</sup>
OPA688U	—	V <sub>L</sub>	V <sub>H</sub>
OPA689U	—	V <sub>L</sub>	V <sub>H</sub>

NOTE: (1) DNC means do not connect.

TABLE I. Supported Exceptions to Pinout in Figure 1.

## CIRCUIT

The circuit schematic in Figure 2 shows the connections for all possible components. Each model will only use some of the components.

## COMPONENTS

Components that have RF performance similar to the ones in Table II may be substituted. C<sub>1</sub> and C<sub>2</sub> need a larger voltage rating for ±15V dual supplies.

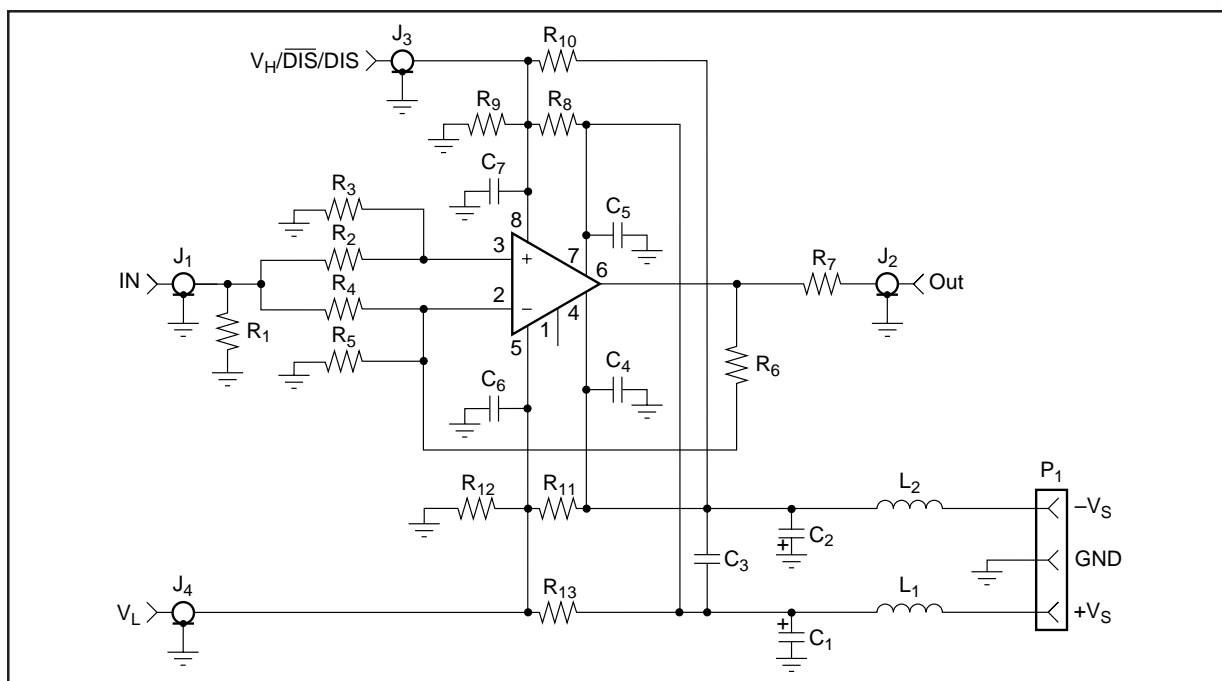

FIGURE 2. Circuit Schematic for DEM-OPA68xU.

PART	DESCRIPTION
C <sub>1</sub> , C <sub>2</sub>	Tantalum Chip Capacitor, SMD EIA size 3528, 20V
C <sub>3</sub> - C <sub>7</sub>	Multi-Layer Ceramic Chip Cap., SMD 1206, 50V
J <sub>1</sub> - J <sub>4</sub>	SMA or SMB Board Jack (Amphenol 901-144-8)
L <sub>1</sub> , L <sub>2</sub>	EMI-Suppression Ferrite Chip, SMD 1206 (Steward LI 1206 B 900 R)
P <sub>1</sub>	Terminal Block, 3.5mm centers (On-Shore Technology ED555/3DS)
R <sub>1</sub> - R <sub>13</sub>	Metal Film Chip Resistor, SMD 1206, 1/8W

TABLE II. Component Descriptions.

R<sub>1</sub> and R<sub>7</sub> set the I/O impedance, R<sub>2</sub> - R<sub>6</sub> set the gain, and C<sub>1</sub> - C<sub>5</sub> are supply bypass capacitors. C<sub>3</sub> is optional; it adds a bypass between the supplies, which improves distortion performance for some models. L<sub>1</sub> and L<sub>2</sub> are ferrite chips that can reduce interactions with the power supply at high frequencies. If not desired, they can be replaced with 0Ω resistors. R<sub>8</sub> - R<sub>13</sub>, C<sub>6</sub> and C<sub>7</sub> are optional components that support op amps with special functions (see Table I).

For single supply operation, do not connect L<sub>2</sub>; otherwise, the -V<sub>S</sub> input to P<sub>1</sub> would be at ground potential.

**Standard Current-Feedback Op Amps**—These op amps have the pinout shown in Figure 1. Table III shows typical values used for these parts. To select component values for your op amp (especially R<sub>6</sub>), consult its data sheet.

COMPONENT	DUAL SUPPLY (G = +2)	DUAL SUPPLY (G = -1)	SINGLE SUPPLY (G = +1)
R <sub>1</sub>	49.9Ω	57.6Ω	49.9Ω
R <sub>2</sub>	10.0Ω	Open	10.0Ω
R <sub>3</sub>	Open	10.0Ω	Open
R <sub>4</sub>	Open	402Ω	Open
R <sub>5</sub>	402Ω	Open	Open
R <sub>6</sub>	402Ω	402Ω	402Ω
R <sub>7</sub>	49.9Ω	49.9Ω	49.9Ω
R <sub>8</sub> - R <sub>13</sub>	Open	Open	Open
C <sub>1</sub>	2.2μF	2.2μF	2.2μF
C <sub>2</sub>	2.2μF	2.2μF	Open
C <sub>3</sub>	0.01μF	0.01μF	Open
C <sub>4</sub>	0.1μF	0.1μF	0Ω
C <sub>5</sub>	0.1μF	0.1μF	0.1μF
C <sub>6</sub> , C <sub>7</sub>	Open	Open	Open

NOTE: The values and gains shown will not work for all current-feedback op amps. See the data sheet to select proper values. The I/O impedances are 50Ω.

TABLE III. Standard Current-Feedback Op Amps.

**Standard Voltage-Feedback Op Amps**—These op amps have the pinout shown in Figure 1. Table IV shows typical values used for these parts. To select component values for your op amp, consult its data sheet.

**OPA628U and OPA64xU**—These op amps have additional supply pins (see Table I) to improve distortion. Use the values in Table IV, except for the changes shown in Table V (the OPA64xP family will function without these changes, but with reduced distortion performance).

COMPONENT	DUAL SUPPLY (G = +2)	DUAL SUPPLY (G = -1)	SINGLE SUPPLY (G = +1)
R <sub>1</sub>	49.9Ω	57.6Ω	49.9Ω
R <sub>2</sub>	178Ω	Open	0Ω
R <sub>3</sub>	Open	210Ω	Open
R <sub>4</sub>	Open	402Ω	Open
R <sub>5</sub>	402Ω	Open	Open
R <sub>6</sub>	402Ω	402Ω	24.9Ω
R <sub>7</sub>	49.9Ω	49.9Ω	49.9Ω
R <sub>8</sub> - R <sub>13</sub>	Open	Open	Open
C <sub>1</sub>	2.2μF	2.2μF	2.2μF
C <sub>2</sub>	2.2μF	2.2μF	Open
C <sub>3</sub>	0.01μF	0.01μF	Open
C <sub>4</sub>	0.1μF	0.1μF	0Ω
C <sub>5</sub>	0.1μF	0.1μF	0.1μF
C <sub>6</sub> , C <sub>7</sub>	Open	Open	Open

NOTE: The values and gains shown will not work for all voltage-feedback op amps. See the individual op amp data sheet to select proper values. The I/O impedances are 50Ω.

TABLE IV. Standard Voltage-Feedback Op Amps.

COMPONENT	DUAL SUPPLY (G = )+2	DUAL SUPPLY (G = -1)	SINGLE SUPPLY (G = +1)
R <sub>8</sub> , R <sub>11</sub>	0Ω	0Ω	0Ω
C <sub>1</sub>	4.7μF	4.7μF	4.7μF
C <sub>2</sub>	4.7μF	4.7μF	Open
C <sub>4</sub> , C <sub>6</sub>	0.1μF	0.1μF	0Ω
C <sub>5</sub> , C <sub>7</sub>	0.1μF	0.1μF	0.1μF

TABLE V. OPA628U and OPA64xU Changes.

**OPA63xU**—Pin 8 disables the output when high (OPA632 and OPA635). Table VII shows different ways to set up pin 8's voltage using R<sub>8</sub>, R<sub>9</sub> and C<sub>7</sub>. Use Table IV for the other components, except for the changes shown in Table VI; note these are all single supply configurations.

COMPONENT	SINGLE SUPPLY (G = +2)	SINGLE SUPPLY (G = -1)	SINGLE SUPPLY (G = +1)
C <sub>4</sub>	0Ω	0Ω	0Ω

TABLE VI. OPA63xU Changes.

CONFIGURATION	R <sub>8</sub>	C <sub>9</sub>
External Source	Open	49.9Ω
On	Open	0Ω
Off	0Ω	Open

TABLE VII. Disable Pin—OPA632U and OPA635U.

**OPA680U**—Pin 8 disables the output when low. Table VIII shows different ways to set up pin 8's voltage using R<sub>8</sub>, R<sub>9</sub> and C<sub>7</sub>. Use Table IV for the other components.

CONFIGURATION	R <sub>8</sub>	R <sub>9</sub>	C <sub>7</sub>
External Source	Open	49.9Ω	Open
On	Open	Open	0.1μF
Off	Open	0Ω	Open

TABLE VIII. Disable Pin—OPA68xU.

**OPA681U**—Pin 8 disables the output when low. Table VIII shows different ways to set up pin 8’s voltage using  $R_8$ ,  $R_9$  and  $C_7$ . Use Table III for the other components.

**OPA682U**—The OPA682U uses internal resistors to set the gain at +1, +2, or –1. Pin 8 disables the output when low. Table VIII shows different ways to set up pin 8’s voltage using  $R_8$ ,  $R_9$  and  $C_7$ . Use Table III for the other components, except for the changes shown in Table IX.

COMPONENT	DUAL SUPPLY (G = +2)	DUAL SUPPLY (G = –1)	SINGLE SUPPLY (G = +1)
$R_4$	Open	0 $\Omega$	Open
$R_5$	0 $\Omega$	Open	Open
$R_6$	Open	Open	Open

TABLE IX. OPA682U Changes.

**OPA686U**—Use Table X for the higher gains needed by this part, and Table IV for the other component values. Extra care is needed to ensure pin 8 is not connected (see Table I).

COMPONENT	DUAL SUPPLY (G = +10)	DUAL SUPPLY (G = –10)	SINGLE SUPPLY (G = +20)
$R_1$	49.9 $\Omega$	Open	49.9 $\Omega$
$R_2$	20.0 $\Omega$	Open	10.0 $\Omega$
$R_3$	Open	10.0 $\Omega$	Open
$R_4$	Open	49.9 $\Omega$	Open
$R_5$	49.9 $\Omega$	Open	26.1 $\Omega$
$R_6$	453 $\Omega$	499 $\Omega$	499 $\Omega$

TABLE X. OPA686U Changes.

**OPA688U**—This VLA™ (Voltage Limiting Amplifier) has two inputs ( $V_H$  and  $V_L$  in Table I), which limit the output voltage swing. Table XI shows different ways to set up pin 5’s and pin 8’s voltages using  $R_8 - R_{13}$  and  $C_5 - C_7$ . Use Table IV for the other components.

Note that this board would require modification for the single-supply circuit shown in the OPA688 data sheet. In dual supply applications, using  $R_{10}$  instead of  $R_8$  makes  $V_H$  negative, and using  $R_{13}$  instead of  $R_{11}$  makes  $V_L$  positive.

COMPONENT	DUAL SUPPLY (G = +2)	DUAL SUPPLY (G = –1)	SINGLE SUPPLY (G = +1)
$R_8$	3.01k $\Omega$	3.01k $\Omega$	549 $\Omega$
$R_9$	1.91k $\Omega$	1.91k $\Omega$	1.58k $\Omega$
$R_{11}$	3.01k $\Omega$	3.01k $\Omega$	Open
$R_{12}$	1.91k $\Omega$	1.91k $\Omega$	549 $\Omega$
$R_{13}$	Open	Open	1.58k $\Omega$
$C_5 - C_7$	0.1 $\mu$ F	0.1 $\mu$ F	0.1 $\mu$ F

TABLE XI. Limiting Pins—OPA68xU.

**OPA689U**—This VLA™ is the high gain-stable version of the OPA688U. Set up this op amp the same as the OPA688U, except for the changes shown in Table XII.

COMPONENT	DUAL SUPPLY (G = +6)	DUAL SUPPLY (G = –6)	SINGLE SUPPLY (G = +6)
$R_1$	49.9 $\Omega$	82.5 $\Omega$	49.9 $\Omega$
$R_2$	100 $\Omega$	Open	100 $\Omega$
$R_3$	Open	130 $\Omega$	Open
$R_4$	Open	124 $\Omega$	Open
$R_5$	150 $\Omega$	Open	150 $\Omega$
$R_6$	750 $\Omega$	750 $\Omega$	750 $\Omega$

TABLE XII. OPA689U Changes.

## BOARD LAYOUT

This demonstration board is a two layer PCB. It uses a ground plane on the bottom and signal and power traces on the top. The ground plane has been opened up around op amp pins sensitive to capacitive loading. Power supply traces are laid out to keep current loop areas to a minimum. The SMA (or SMB) connectors may be mounted either vertically or horizontally.

The location and type of capacitors used for power-supply bypassing are crucial to high frequency amplifiers. The tantalum capacitors,  $C_1$  and  $C_2$ , do not need to be as close to pins 7 and 4 on your PCB, and may be shared with other amplifiers.

See the individual op amp data sheet for more information on proper board layout techniques, and component selection.

## MEASUREMENT TIPS

This demonstration board and the component values shown are designed to operate in a 50 $\Omega$  environment. Most data sheet plots are obtained this way. Change the component values for different input and output impedance levels.

Do not use high impedance probes; they represent a heavy capacitive load to the op amps, and will alter their response. Instead, use low impedance ( $\leq 500\Omega$ ) probes with adequate bandwidth. The probe input capacitance and resistance set an upper limit on the measurement bandwidth. If a high impedance probe must be used, place a 100 $\Omega$  resistor on the probe tip to isolate its capacitance from the circuit.

(a)

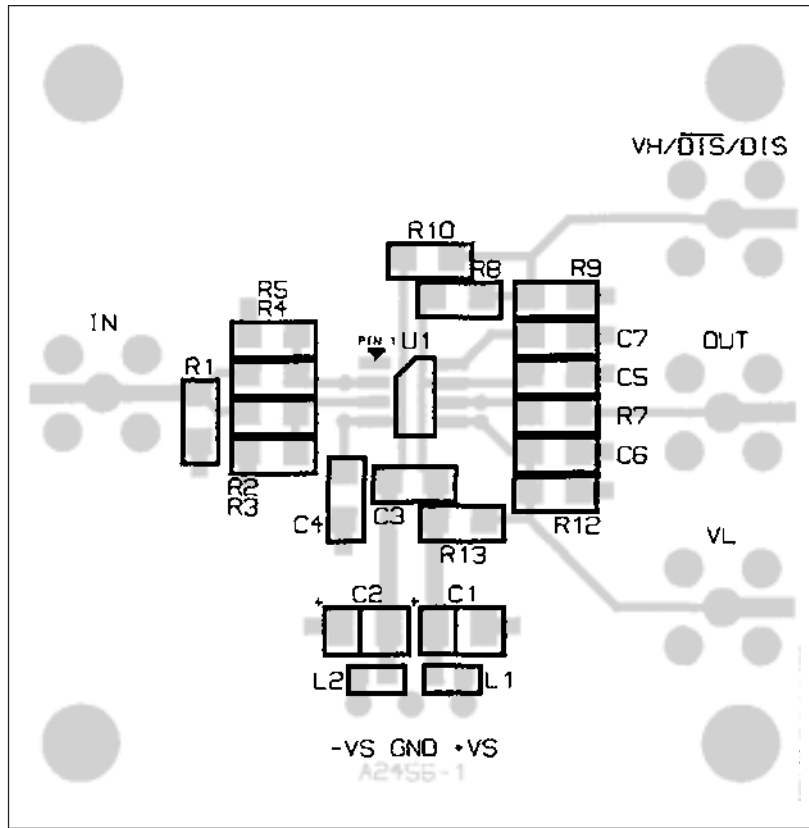

(b)

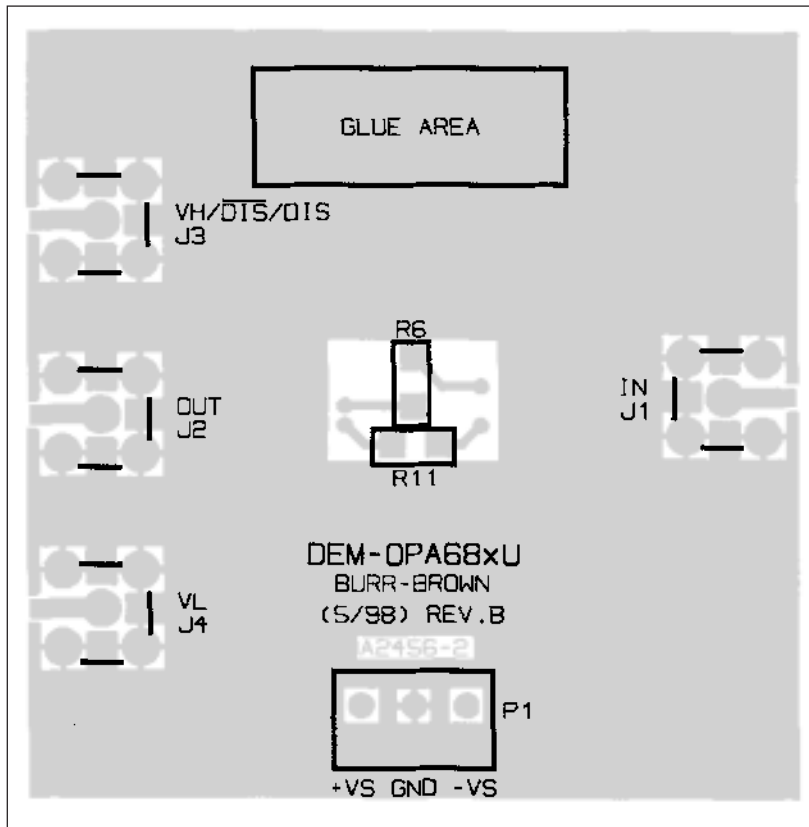

FIGURE 3. DEM-OPA68xU Demonstration Board Layout; (a) Component Side Silkscreen and Metal, (b) Ground Plane Side Silkscreen and Metal (bottom view).