

Am29F800T/Am29F800B

8 Megabit (1,048,576 x 8-Bit/524,288 x 16-Bit) CMOS
5.0 Volt-only, Sector Erase Flash Memory

DISTINCTIVE CHARACTERISTICS

- **5.0 V \pm 10% for read and write operations**
 - Minimizes system level power requirements
- **Compatible with JEDEC standards**
 - Pinout and software compatible with single-power-supply flash
 - Superior inadvertent write protection
- **Package options**
 - 44-pin SO
 - 48-pin TSOP
- **Minimum 100,000 write/erase cycles guaranteed**
- **High performance**
 - 70 ns maximum access time
- **Sector erase architecture**
 - One 16 Kbyte, two 8 Kbytes, one 32 Kbyte, and fifteen 64 Kbytes
 - Any combination of sectors can be erased. Also supports full chip erase.
- **Sector protection**
 - Hardware method that disables any combination of sectors from write or erase operations. Implemented using standard PROM programming equipment.
- **Embedded Erase Algorithm**
 - Automatically pre-programs and erases the chip or any sector
- **Embedded Program Algorithm**
 - Automatically programs and verifies data at specified address
- **Data Polling and Toggle Bit feature for detection of program or erase cycle completion**
- **Ready/Busy output (RY/ $\overline{\text{BY}}$)**
 - Hardware method for detection of program or erase cycle completion
- **Erase Suspend/Resume**
 - Supports reading data from or programming data to a sector not being erased
- **Low power consumption**
 - 20 mA typical active read current for Byte Mode
 - 28 mA typical active read current for Word Mode
 - 30 mA typical program/erase current
- **Enhanced power management for standby mode**
 - 1 μA typical standby current
- **Boot Code Sector Architecture**
 - T = Top sector
 - B = Bottom sector
- **Hardware RESET pin**
 - Resets internal state machine to the read mode

GENERAL DESCRIPTION

The Am29F800 is an 8 Mbit, 5.0 Volt-only Flash memory organized as 1 Mbyte of 8 bits each or 512K words of 16 bits each. For flexible erase capability, the 8 Mbits of data are divided into 19 sectors as follows: one 16 Kbyte, two 8 Kbyte, one 32 Kbyte, and fifteen 64 Kbyte. Eight bits of data appear on DQ0–DQ7 in byte mode; in word mode 16 bits appear on DQ0–DQ15. The Am29F800 is offered in 44-pin SO and 48-pin TSOP packages. This device is designed to be programmed in-system with the standard system 5.0 Volt V_{CC} supply. A V_{PP} of 12.0 volts is not required for program or erase operations. The device can also be programmed in standard EPROM programmers.

The standard Am29F800 offers access times of 70 ns, 90 ns, 120 ns, and 150 ns, allowing high-speed microprocessors to operate without wait states. To eliminate bus contention, the device has separate chip enable ($\overline{\text{CE}}$), write enable ($\overline{\text{WE}}$), and output enable ($\overline{\text{OE}}$) controls.

The Am29F800 is entirely command set compatible with the JEDEC single-power-supply Flash standard. Commands are written to the command register using standard microprocessor write timings. Register contents serve as input to an internal state-machine which controls the erase and program circuitry. Write cycles also internally latch addresses and data needed for the programming and erase operations. Reading data out

of the device is similar to reading from 12.0 Volt Flash or EPROM devices.

The Am29F800 is programmed by executing the program command sequence. This will invoke the Embedded Program Algorithm which is an internal algorithm that automatically times the program pulse widths and verifies proper cell margin. Erase is accomplished by executing the erase command sequence. This will invoke the Embedded Erase Algorithm which is an internal algorithm that automatically preprograms the array if it is not already programmed before executing the erase operation. During erase, the device automatically times the erase pulse widths and verifies proper cell margin.

This device also features a sector erase architecture. This allows for sectors of memory to be erased and reprogrammed without affecting the data contents of other sectors. A sector is typically erased and verified within 1.5 seconds. The Am29F800 is erased when shipped from the factory.

The Am29F800 device also features hardware sector protection. This feature will disable both program and erase operations in any combination of nineteen sectors of memory.

AMD has implemented an Erase Suspend feature that enables the user to put erase on hold for any period of time to read data from or program data to a sector that was not being erased. Thus, true background erase can be achieved.

The device features single 5.0 Volt power supply operation for both read and write functions. Internally generated and regulated voltages are provided for the program and erase operations. A low V_{CC} detector automatically inhibits write operations during power transitions. The end of program or erase is detected by the RY/BY pin, Data Polling of DQ7, or by the Toggle Bit (DQ6). Once the end of a program or erase cycle has been completed, the device automatically resets to the read mode.

The Am29F800 also has a hardware \overline{RESET} pin. When this pin is driven low, execution of any Embedded Program Algorithm or Embedded Erase Algorithm will be terminated. The internal state machine will then be reset into the read mode. The \overline{RESET} pin may be tied to the system reset circuitry. Therefore, if a system reset occurs during the Embedded Program Algorithm or Embedded Erase Algorithm, the device will be automatically reset to the read mode and will have erroneous data stored in the address locations being operated on. These locations will need re-writing after the Reset. Resetting the device will enable the system's microprocessor to read the boot-up firmware from the Flash memory.

AMD's Flash technology combines years of Flash memory manufacturing experience to produce the highest levels of quality, reliability and cost effectiveness. The Am29F800 memory electrically erases all bits within a sector simultaneously via Fowler-Nordheim tunneling. The bytes/words are programmed one byte/word at a time using the EPROM programming mechanism of hot electron injection.

PRODUCT SELECTOR GUIDE

Family Part No:	Am29F800			
Ordering Part No: $V_{CC} = 5.0\text{ V} \pm 10\%$	-70	-90	-120	-150
Max Access Time (ns)	70	90	120	150
\overline{CE} (E) Access (ns)	70	90	120	150
\overline{OE} (G) Access (ns)	30	35	50	55

BLOCK DIAGRAM

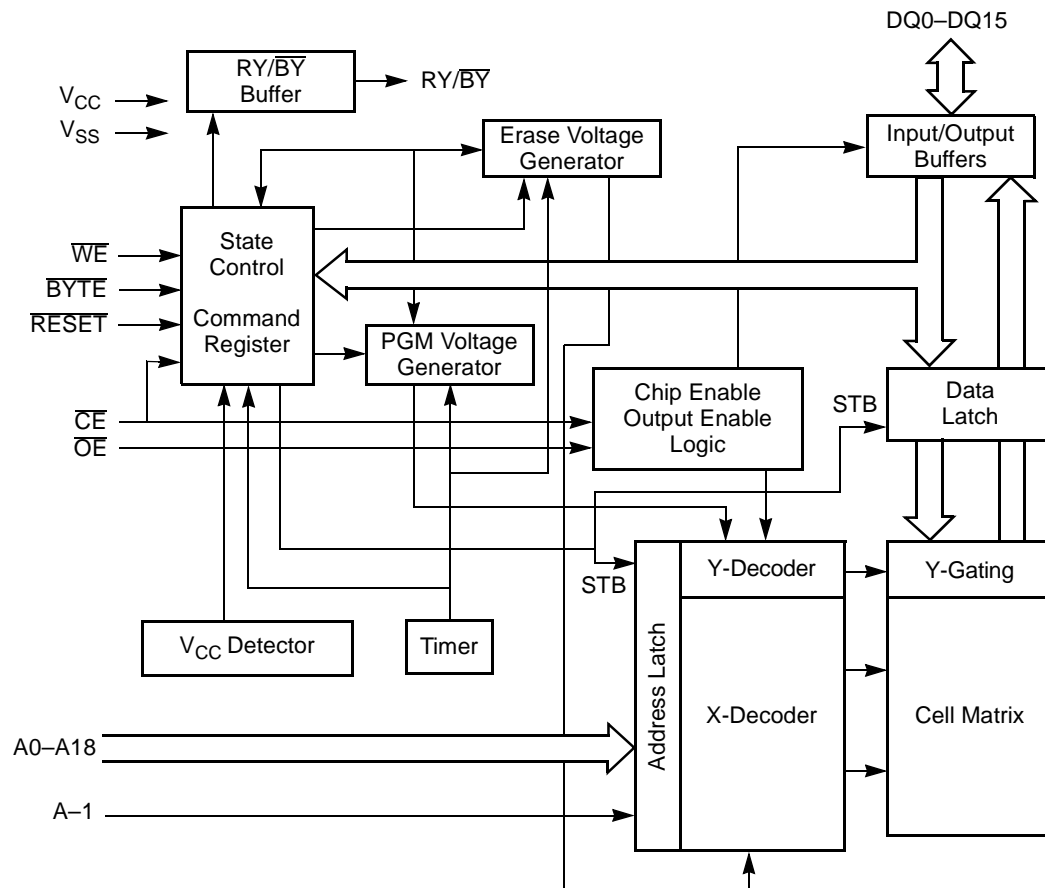

20375C-1

CONNECTION DIAGRAMS

SO

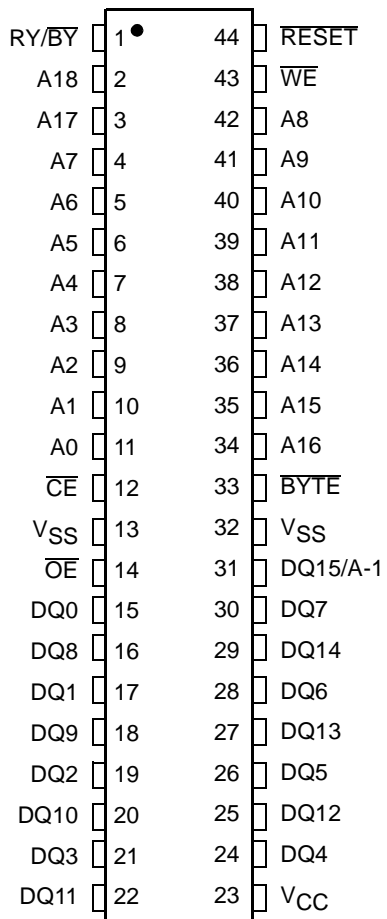

20375C-2

CONNECTION DIAGRAMS



Standard TSOP

20375C-3

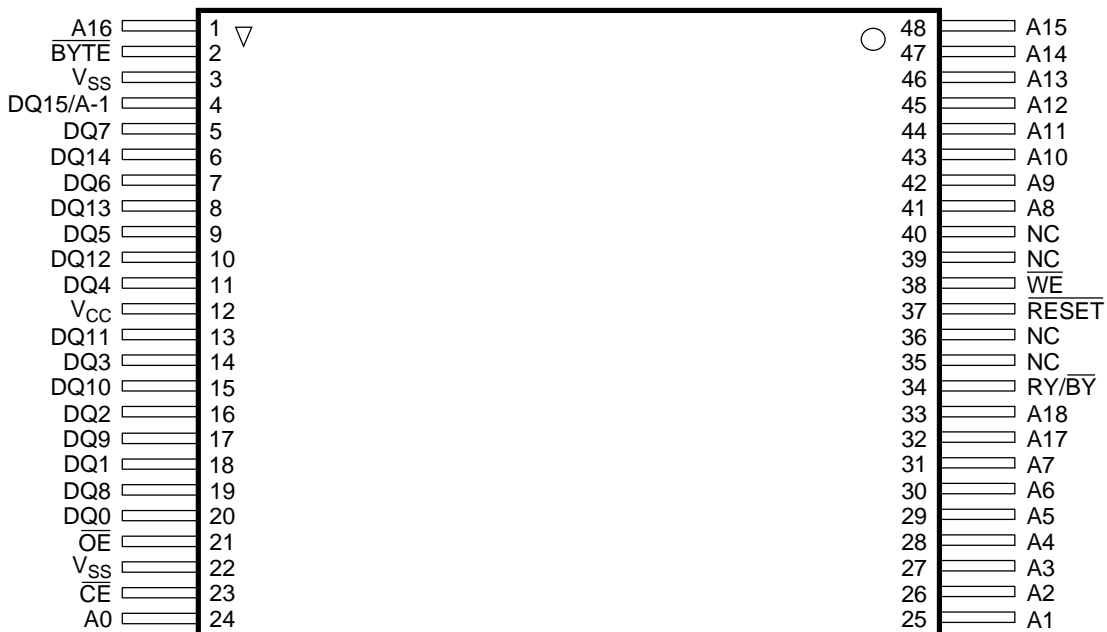

Reverse TSOP

20375C-4

PIN CONFIGURATION

- A0–A18 = 19 Addresses
- $\overline{\text{BYTE}}$ = Selects 8-bit or 16-bit mode
- $\overline{\text{CE}}$ = Chip Enable
- DQ0–DQ14 = 15 Data Inputs/Outputs
- DQ15/A-1 = DQ15 Data Input/Output, A-1 Address Mux
- NC = Pin Not Connected Internally
- $\overline{\text{OE}}$ = Output Enable
- $\overline{\text{RESET}}$ = Hardware Reset Pin, Active Low
- RY/ $\overline{\text{BY}}$ = Ready/ $\overline{\text{Busy}}$ Output
- V_{CC} = +5.0 Volt Single-Power Supply ($\pm 10\%$ for -70, -90, -120, -150)
- V_{SS} = Device Ground
- $\overline{\text{WE}}$ = Write Enable

LOGIC SYMBOL

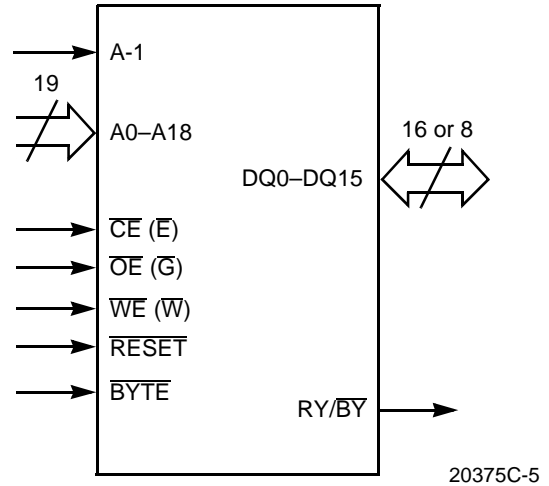

ORDERING INFORMATION

Standard Products

AMD standard products are available in several packages and operating ranges. The order number (Valid Combination) is formed by a combination of:

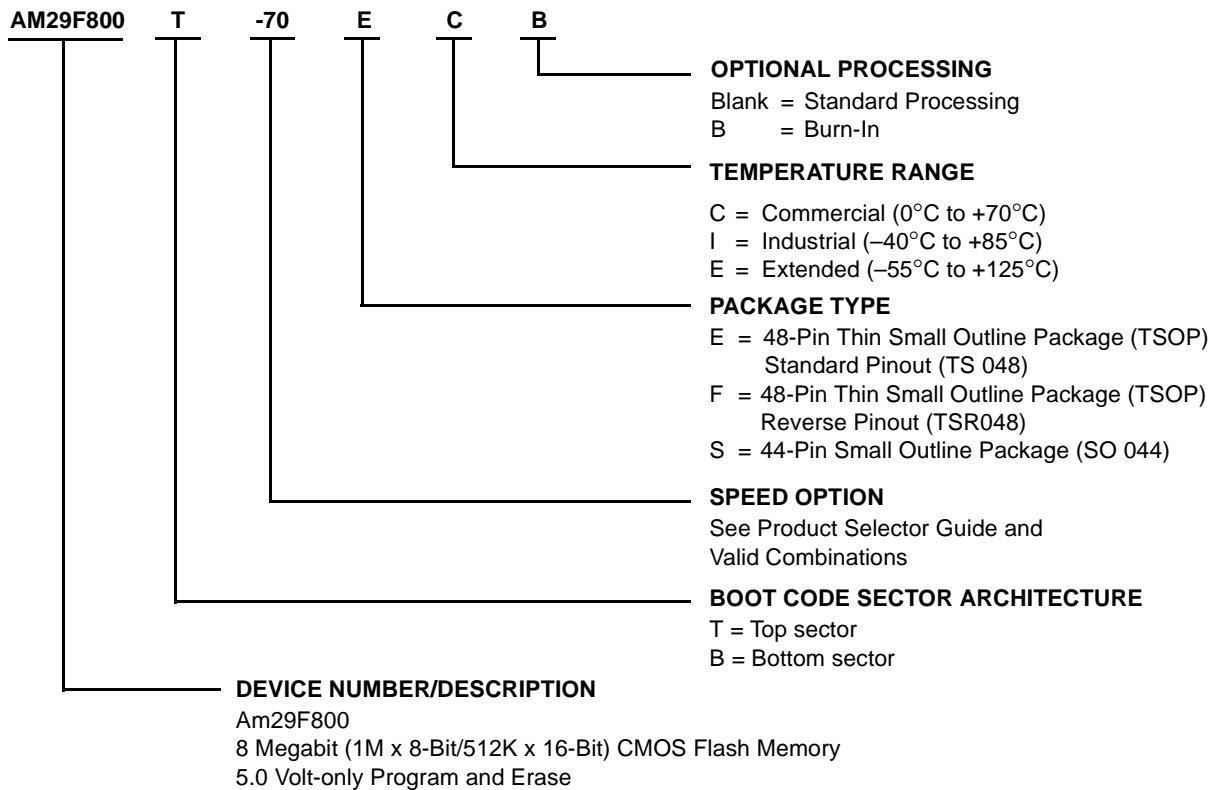

Valid Combinations	
AM29F800T-70, AM29F800B-70	EC, EI, FC, FI, SC, SI
AM29F800T-90, AM29F800B-90	EC, EI, EE, EEB, FC, FI, FE, FEB, SC, SI, SE, SEB
AM29F800T-120, AM29F800B-120	
AM29F800T-150, AM29F800B-150	

Valid Combinations

Valid Combinations list configurations planned to be supported in volume for this device. Consult the local AMD sales office to confirm availability of specific valid combinations and to check on newly released combinations.

Table 1. Am29F800 User Bus Operations (BYTE = V_{IH})

Operation	\overline{CE}	\overline{OE}	\overline{WE}	A0	A1	A6	A9	DQ0–DQ15	RESET
Autoselect, AMD Manuf. Code (Note 1)	L	L	H	L	L	L	V_{ID}	Code	H
Autoselect Device Code (Note 1)	L	L	H	H	L	L	V_{ID}	Code	H
Read	L	L	X	A0	A1	A6	A9	D_{OUT}	H
Standby	H	X	X	X	X	X	X	HIGH Z	H
Output Disable	L	H	H	X	X	X	X	HIGH Z	H
Write	L	H	L	A0	A1	A6	A9	D_{IN}	H
Verify Sector Protect (Note 2)	L	L	H	L	H	L	V_{ID}	Code	H
Temporary Sector Unprotect	X	X	X	X	X	X	X	X	V_{ID}
Hardware Reset	X	X	X	X	X	X	X	HIGH Z	L

Table 2. Am29F800 User Bus Operations (BYTE = V_{IL})

Operation	\overline{CE}	\overline{OE}	\overline{WE}	A0	A1	A6	A9	DQ0–DQ7	DQ8–DQ15	RESET
Autoselect, AMD Manuf. Code (Note 1)	L	L	H	L	L	L	V_{ID}	Code	HIGH Z	H
Autoselect Device Code (Note 1)	L	L	H	H	L	L	V_{ID}	Code	HIGH Z	H
Read	L	L	X	A0	A1	A6	A9	D_{OUT}	HIGH Z	H
Standby	H	X	X	X	X	X	X	HIGH Z	HIGH Z	H
Output Disable	L	H	H	X	X	X	X	HIGH Z	HIGH Z	H
Write	L	H	L	A0	A1	A6	A9	D_{IN}	HIGH Z	H
Verify Sector Protect (Note 2)	L	L	H	L	H	L	V_{ID}	Code	HIGH Z	H
Temporary Sector Unprotect	X	X	X	X	X	X	X	X	HIGH Z	V_{ID}
Hardware Reset	X	X	X	X	X	X	X	HIGH Z	HIGH Z	L

Legend:

L = logic 0, H = logic 1, X = Don't Care. See Characteristics for voltage levels.

Notes:

1. Manufacturer and device codes may also be accessed via a command register write sequence. Refer to Table 7.
2. Refer to the section on Sector Protection.

Read Mode

The Am29F800 has two control functions which must be satisfied in order to obtain data at the outputs. \overline{CE} is the power control and should be used for device selection. \overline{OE} is the output control and should be used to gate data to the output pins if a device is selected.

Address access time (t_{ACC}) is equal to the delay from stable addresses to valid output data. The chip enable access time (t_{CE}) is the delay from stable addresses and stable \overline{CE} to valid data at the output pins. The output enable access time is the delay from the falling edge of \overline{OE} to valid data at the output

pins (assuming the addresses have been stable for at least $t_{ACC}-t_{OE}$ time).

Standby Mode

There are two ways to implement the standby mode on the Am29F800 device, both using the \overline{CE} pin.

A CMOS standby mode is achieved with the \overline{CE} input held at $V_{CC} \pm 0.3V$. Under this condition the current is typically reduced to less than 5 μA . A TTL standby mode is achieved with the \overline{CE} pin held at V_{IH} . Under this condition the current is typically reduced to 1 mA.

In the standby mode the outputs are in the high impedance state, independent of the \overline{OE} input.

Output Disable

With the \overline{OE} input at a logic high level (V_{IH}), output from the device is disabled. This will cause the output pins to be in a high impedance state.

Autoselect

The autoselect mode allows the reading of a binary code from the device and will identify its manufacturer and type. This mode is intended for use by programming equipment for the purpose of automatically matching the device to be programmed with its corresponding programming algorithm. This mode is functional over the entire temperature range of the device.

To activate this mode, the programming equipment must force V_{ID} (11.5 V to 12.5 V) on address pin A9. Two identifier bytes may then be sequenced from the device outputs by toggling address A0 from V_{IL} to V_{IH} . All addresses are don't cares except A0, A1, and A6 (see Table 3).

The manufacturer and device codes may also be read via the command register, for instances when the Am29F800 is erased or programmed in a system without access to high voltage on the A9 pin. The command sequence is illustrated in Table 4 (see Autoselect Command Sequence).

Byte 0 ($A0 = V_{IL}$) represents the manufacturer's code (AMD=01H) and byte 1 ($A0 = V_{IH}$) the device identifier code (Am29F800T = D6H and Am29F800B = 58H for x8 mode; Am29F800T = 22D6H and Am29F800B = 2258H for x16 mode). These two bytes/words are given in the table below. All identifiers for manufacturer and device will exhibit odd parity with DQ7 defined as the parity bit. In order to read the proper device codes when executing the Autoselect, A1 must be V_{IL} (see Tables 3 and 4).

The autoselect mode also facilitates the determination of sector protection in the system. By performing a read operation at the address location XX02H with the higher order address bits A12–A18 set to the desired sector address, the device will return 01H for a protected sector and 00H for a non-protected sector.

Table 3. Am29F800 Sector Protection Verify Autoselect Codes

Type		A12–A18	A6	A1	A0	Code (HEX)
Manufacturer Code—AMD		X	V_{IL}	V_{IL}	V_{IL}	01H
Am29F800 Device	Am29F800T	Byte	X	V_{IL}	V_{IL}	D6H
		Word	X	V_{IL}	V_{IH}	22D6H
	Am29F800B	Byte	X	V_{IL}	V_{IL}	58H
		Word	X	V_{IL}	V_{IH}	2258H
Sector Protection		Sector Address	V_{IL}	V_{IH}	V_{IL}	01H*

*Outputs 01H at protected sector addresses

Table 4. Expanded Autoselect Code Table

Type		Code	DQ 15	DQ 14	DQ 13	DQ 12	DQ 11	DQ 10	DQ 9	DQ 8	DQ 7	DQ 6	DQ 5	DQ 4	DQ 3	DQ 2	DQ 1	DQ 0
Manufacturer Code—AMD		01H	0	0	0	0	0	0	0	0	0	0	0	0	0	0	0	1
Am29F800 Device	Am29F800T(B) (W)	D6H	A-1	HI-Z	HI-Z	HI-Z	HI-Z	HI-Z	HI-Z	HI-Z	1	1	0	1	0	1	1	0
		22D6H	0	0	1	0	0	0	1	0	1	1	0	1	0	1	1	0
	Am29F800B(B) (W)	58H	A-1	HI-Z	HI-Z	HI-Z	HI-Z	HI-Z	HI-Z	HI-Z	0	1	0	1	1	0	0	0
		2258H	0	0	1	0	0	0	1	0	0	1	0	1	1	0	0	0
Sector Protection		01H	0	0	0	0	0	0	0	0	0	0	0	0	0	0	0	1

(B) – Byte mode

(W) – Word mode

Table 5. Sector Address Tables (Am29F800T)

	A18	A17	A16	A15	A14	A13	A12	Sector Size	(x16) Address Range	(x8) Address Range
SA0	0	0	0	0	X	X	X	64 Kbytes 32 Kwords	00000h–07FFFh	00000h–0FFFFh
SA1	0	0	0	1	X	X	X	64 Kbytes 32 Kwords	08000h–0FFFFh	10000h–1FFFFh
SA2	0	0	1	0	X	X	X	64 Kbytes 32 Kwords	10000h–17FFFh	20000h–2FFFFh
SA3	0	0	1	1	X	X	X	64 Kbytes 32 Kwords	18000h–1FFFFh	30000h–3FFFFh
SA4	0	1	0	0	X	X	X	64 Kbytes 32 Kwords	20000h–27FFFh	40000h–4FFFFh
SA5	0	1	0	1	X	X	X	64 Kbytes 32 Kwords	28000h–2FFFFh	50000h–5FFFFh
SA6	0	1	1	0	X	X	X	64 Kbytes 32 Kwords	30000h–37FFFh	60000h–6FFFFh
SA7	0	1	1	1	X	X	X	64 Kbytes 32 Kwords	38000h–3FFFFh	70000h–7FFFFh
SA8	1	0	0	0	X	X	X	64 Kbytes 32 Kwords	40000h–47FFFh	80000h–8FFFFh
SA9	1	0	0	1	X	X	X	64 Kbytes 32 Kwords	48000h–4FFFFh	90000h–9FFFFh
SA10	1	0	1	0	X	X	X	64 Kbytes 32 Kwords	50000h–57FFFh	A0000h–AFFFFh
SA11	1	0	1	1	X	X	X	64 Kbytes 32 Kwords	58000h–5FFFFh	B0000h–BFFFFh
SA12	1	1	0	0	X	X	X	64 Kbytes 32 Kwords	60000h–67FFFh	C0000h–CFFFFh
SA13	1	1	0	1	X	X	X	64 Kbytes 32 Kwords	68000h–6FFFFh	D0000h–DFFFFh
SA14	1	1	1	0	X	X	X	64 Kbytes 32 Kwords	70000h–77FFFh	E0000h–EFFFFh
SA15	1	1	1	1	0	X	X	32 Kbytes 16 Kwords	78000h–7BFFFh	F0000h–F7FFFh
SA16	1	1	1	1	1	0	0	8 Kbytes 4 Kwords	7C000h–7CFFFh	F8000h–F9FFFh
SA17	1	1	1	1	1	0	1	8 Kbytes 4 Kwords	7D000h–7DFFFh	FA000h–FBFFFh
SA18	1	1	1	1	1	1	X	16 Kbytes 8 Kwords	7E000h–7FFFFh	FC000h–FFFFFh

Note: The address range is A18:A₋₁ if in byte mode ($\overline{BYTE} = V_{IL}$). The address range is A18:A0 if in word mode ($\overline{BYTE} = V_{IH}$).

Table 6. Sector Address Tables (Am29F800B)

	A18	A17	A16	A15	A14	A13	A12	Sector Size	(x16) Address Range	(x8) Address Range
SA0	0	0	0	0	0	0	X	16 Kbytes 8 Kwords	00000h–01FFFh	00000h–03FFFh
SA1	0	0	0	0	0	1	0	8 Kbytes 4 Kwords	02000h–02FFFh	04000h–05FFFh
SA2	0	0	0	0	0	1	1	8 Kbytes 4 Kwords	03000h–03FFFh	06000h–07FFFh
SA3	0	0	0	0	1	X	X	32 Kbytes 16 Kwords	04000h–07FFFh	08000h–0FFFFh
SA4	0	0	0	1	X	X	X	64 Kbytes 32 Kwords	08000h–0FFFFh	10000h–1FFFFh
SA5	0	0	1	0	X	X	X	64 Kbytes 32 Kwords	10000h–17FFFh	20000h–2FFFFh
SA6	0	0	1	1	X	X	X	64 Kbytes 32 Kwords	18000h–1FFFFh	30000h–3FFFFh
SA7	0	1	0	0	X	X	X	64 Kbytes 32 Kwords	20000h–27FFFh	40000h–4FFFFh
SA8	0	1	0	1	X	X	X	64 Kbytes 32 Kwords	28000h–2FFFFh	50000h–5FFFFh
SA9	0	1	1	0	X	X	X	64 Kbytes 32 Kwords	30000h–37FFFh	60000h–6FFFFh
SA10	0	1	1	1	X	X	X	64 Kbytes 32 Kwords	38000h–3FFFFh	70000h–7FFFFh
SA11	1	0	0	0	X	X	X	64 Kbytes 32 Kwords	40000h–47FFFh	80000h–8FFFFh
SA12	1	0	0	1	X	X	X	64 Kbytes 32 Kwords	48000h–4FFFFh	90000h–9FFFFh
SA13	1	0	1	0	X	X	X	64 Kbytes 32 Kwords	50000h–57FFFh	A0000h–AFFFFh
SA14	1	0	1	1	X	X	X	64 Kbytes 32 Kwords	58000h–5FFFFh	B0000h–BFFFFh
SA15	1	1	0	0	X	X	X	64 Kbytes 32 Kwords	60000h–67FFFh	C0000h–CFFFFh
SA16	1	1	0	1	X	X	X	64 Kbytes 32 Kwords	68000h–6FFFFh	D0000h–DFFFFh
SA17	1	1	1	0	X	X	X	64 Kbytes 32 Kwords	70000h–77FFFh	E0000h–EFFFFh
SA18	1	1	1	1	X	X	X	64 Kbytes 32 Kwords	78000h–7FFFFh	F0000h–FFFFFh

Note: The address range is A18:A₋₁ if in byte mode (BYTE = V_{IL}). The address range is A18:A0 if in word mode (BYTE = V_{IH}).

Write

Device erasure and programming are accomplished via the command register. The contents of the register serve as inputs to the internal state machine. The state machine outputs dictate the function of the device.

The command register itself does not occupy any addressable memory location. The register is a latch used to store the commands, along with the address and data information needed to execute the command. The command register is written to by bringing \overline{WE} to V_{IL} , while \overline{CE} is at V_{IL} and \overline{OE} is at V_{IH} . Addresses are latched on the falling edge of \overline{WE} or \overline{CE} , whichever happens later; while data is latched on the rising edge of \overline{WE} or \overline{CE} , whichever happens first. Standard microprocessor write timings are used.

Refer to AC Write Characteristics and the Erase/Programming Waveforms for specific timing parameters.

Sector Protection

The Am29F800 features hardware sector protection. This feature will disable both program and erase operations in any combination of nineteen sectors of memory. The sector protect feature is enabled using *programming equipment at the user's site*. The device is shipped with all sectors unprotected. Alternatively, AMD may program and protect sectors in the factory prior to shipping the device (AMD's ExpressFlash™ Service).

It is possible to determine if a sector is protected in the system by writing an Autoselect command. Performing a read operation at the address location XX02H, where the higher order address bits A12–A18 is the desired sector address, will produce a logical “1” at DQ0 for a protected sector. See Table 3 for Autoselect codes.

Temporary Sector Unprotect

This feature allows temporary unprotection of previously protected sectors of the Am29F800 device in order to change data in-system. The Sector Unprotect mode is activated by setting the \overline{RESET} pin to high voltage (12V). During this mode, formerly protected sectors can be programmed or erased by selecting the sector addresses. Once the 12 V is taken away from the \overline{RESET} pin, all the previously protected sectors will be protected again. Refer to Figures 17 and 18.

Command Definitions

Device operations are selected by writing specific address and data sequences into the command register. **Writing incorrect address and data values or writing them in the improper sequence will reset the device to the read mode.** Table 7 defines the valid register command sequences. Note that the Erase Suspend (B0H) and Erase Resume (30H) commands are valid only while the Sector Erase operation is in progress. Moreover, both Reset/Read commands are functionally equivalent, resetting the device to the read mode.

Table 7. Am29F800 Command Definitions

Command Sequence Read/Reset (Note 2)		Bus Write Cycles Req'd	First Bus Write Cycle		Second Bus Read/Write Cycle		Third Bus Write Cycle		Fourth Bus Read/Write Cycle		Fifth Bus Write Cycle		Sixth Bus Write Cycle	
			Addr	Data	Addr	Data	Addr	Data	Addr	Data	Addr	Data	Addr	Data
Reset/Read	Word	1	XXX	XXF0	RA	RD								
	Byte			F0										
Autoselect Manufacturer ID	Word	3	555	XXAA	2AA	XX55	555	XX90	XX00	XX01				
	Byte		AAA	AA	555	55	AAA	90	00	01				
Autoselect Device ID (Top Boot Block)	Word	3	555	XXAA	2AA	XX55	555	XX90	XX01	22D6				
	Byte		AAA	AA	555	55	AAA	90	02	D6				
Autoselect Device ID (Bottom Boot Block)	Word	3	555	XXAA	2AA	XX55	555	XX90	XX01	2258				
	Byte		AAA	AA	555	55	AAA	90	02	58				
Autoselect Sector Protect Verify (Note 3)	Word	3	555	XXAA	2AA	XX55	555	XX90	(SA) X02	XX00				
	Byte		AAA	AA	555	55	AAA	90	(SA) X04	00 01				
Byte Program	Word	4	555	XXAA	2AA	XX55	555	XXA0	PA	PD				
	Byte		AAA	AA	555	55	AAA	A0						
Chip Erase	Word	6	555	XXAA	2AA	XX55	555	XX80	555	XXAA	2AA	XX55	555	XX10
	Byte		AAA	AA	555	55	AAA	80	AAA	AA	555	55	AAA	10
Sector Erase	Word	6	555	XXAA	2AA	XX55	555	XX80	555	XXAA	2AA	XX55	SA	XX30
	Byte		AAA	AA	555	55	AAA	80	AAA	AA	555	55		30
Erase Suspend (Note 4)	Word	1	XXX	XXB0										
	Byte			B0										
Erase Resume	Word	1	XXX	XX30										
	Byte			30										

Legend:

RA = Address of the memory location to be read.

RD = Data read from location RA during read operation.

PA = Address of the memory location to be programmed. Addresses are latched on the falling edge of the \overline{WE} or \overline{CE} pulse.

PD = Data to be programmed at location PA. Data is latched on the rising edge of \overline{WE} or \overline{CE} pulse.

SA = Address of the sector to be erased. Address bits A18–A12 uniquely select any sector.

Notes:

1. All values are in hexadecimal.
2. See Tables 1 and 2 for description of bus operations.
3. The data is 00H for an unprotected sector group and 01H for a protected sector group. The complete bus address is composed of the sector address (A18–A12), A1 = 1, and A0 = 0.
4. Read and program functions in non-erasing sectors are allowed in the Erase Suspend mode.
5. Address bits A18–A11 are don't care for unlock and command cycles.

Read/Reset Command

The read or reset operation is initiated by writing the read/reset command sequence into the command register. Microprocessor read cycles retrieve array data from the memory. The device remains enabled for reads until the command register contents are altered.

The device will automatically power-up in the read/reset state. In this case, a command sequence is not required to read data. Standard microprocessor read cycles will retrieve array data. This default value ensures that no spurious alteration of the memory content occurs during the power transition. Refer to the AC Read Characteristics and Waveforms for the specific timing parameters.

Autoselect Command

Flash memories are intended for use in applications where the local CPU can alter memory contents. As such, manufacture and device codes must be accessible while the device resides in the target system. PROM programmers typically access the signature codes by raising A9 to a high voltage. However, multiplexing high voltage onto the address lines is not generally a desirable system design practice.

The device contains an autoselect command operation to supplement traditional PROM programming methodology. The operation is initiated by writing the autoselect command sequence into the command register. Following the command write, a read cycle from address XX00H retrieves the manufacture code of 01H. A read cycle from address XX01H returns the device code (Am29F800T = D6H and Am29F800B = 58H for x8 mode; Am29F800T = 22D6H and Am29F800B = 2258H for x16 mode) (see Tables 3 and 4).

All manufacturer and device codes will exhibit odd parity with DQ7 defined as the parity bit.

Furthermore, the write protect status of sectors can be read in this mode. Scanning the sector addresses (A18, A17, A16, A15, A14, A13, and A12) while (A6, A1, A0) = (0, 1, 0) will produce a logical "1" at device output DQ0 for a protected sector.

To terminate the operation, it is necessary to write the read/reset command sequence into the register.

Byte/Word Programming

The device is programmed on a byte-by-byte (or word-by-word) basis. Programming is a four bus cycle operation. There are two "unlock" write cycles. These are followed by the program set-up command and data write cycles. Addresses are latched on the falling edge of \overline{CE} or \overline{WE} , whichever happens later and the data is latched on the rising edge of \overline{CE} or \overline{WE} , whichever happens first. The rising edge of \overline{CE} or \overline{WE} (whichever happens first) begins programming using the Embedded Program Algorithm. Upon executing the algorithm,

the system is *not* required to provide further controls or timings. The device will automatically provide adequate internally generated program pulses and verify the programmed cell margin.

The automatic programming operation is completed when the data on DQ7 (also used as \overline{Data} Polling) is equivalent to the data written to this bit at which time the device returns to the read mode and addresses are no longer latched (see Table 8, Hardware Sequence Flags). Therefore, the device requires that a valid address to the device be supplied by the system at this particular instance of time for \overline{Data} Polling operations. \overline{Data} Polling must be performed at the memory location which is being programmed.

Any commands written to the chip during the Embedded Program Algorithm will be ignored. If a hardware reset occurs during the programming operation, the data at that particular location will be corrupted.

Programming is allowed in any sequence and across sector boundaries. Beware that a data "0" cannot be programmed back to a "1". Attempting to do so may cause the device to exceed programming time limits (DQ5 = 1) or result in an apparent success, according to the data polling algorithm, but a read from reset/read mode will show that the data is still "0". Only erase operations can convert "0"s to "1"s.

Figure 1 illustrates the Embedded Programming Algorithm using typical command strings and bus operations.

Chip Erase

Chip erase is a six bus cycle operation. There are two "unlock" write cycles. These are followed by writing the "set-up" command. Two more "unlock" write cycles are then followed by the chip erase command.

Chip erase does *not* require the user to program the device prior to erase. Upon executing the Embedded Erase Algorithm command sequence the device will automatically program and verify the entire memory for an all zero data pattern prior to electrical erase. The erase is performed sequentially on all sectors at the same time (see Table "Erase and Programming Performance"). The system is not required to provide any controls or timings during these operations.

The automatic erase begins on the rising edge of the last \overline{WE} pulse in the command sequence and terminates when the data on DQ7 is "1" (see Write Operation Status section) at which time the device returns to read the mode.

Figure 2 illustrates the Embedded Erase Algorithm using typical command strings and bus operations.

Sector Erase

Sector erase is a six bus cycle operation. There are two “unlock” write cycles. These are followed by writing the “set-up” command. Two more “unlock” write cycles are then followed by the sector erase command. The sector address (any address location within the desired sector) is latched on the falling edge of \overline{WE} , while the command (30H) is latched on the rising edge of \overline{WE} . After a time-out of 80 μ s from the rising edge of the last sector erase command, the sector erase operation will begin.

Multiple sectors may be erased sequentially by writing the six bus cycle operations as described above. This sequence is followed with writes of the Sector Erase command to addresses in other sectors desired to be sequentially erased. The time between writes must be less than 80 μ s otherwise that command will not be accepted and erasure will start. It is recommended that processor interrupts be disabled during this time to guarantee this condition. The interrupts can be re-enabled after the last Sector Erase command is written. A time-out of 80 μ s from the rising edge of the last \overline{WE} will initiate the execution of the Sector Erase command(s). If another falling edge of the \overline{WE} occurs within the 80 μ s time-out window the timer is reset. (Monitor DQ3 to determine if the sector erase timer window is still open. See DQ3, Sector Erase Timer.) Any command other than Sector Erase or Erase Suspend during this period will reset the device to the read mode, ignoring the previous command string. In that case, restart the erase on those sectors and allow them to complete.

Loading the sector erase buffer may be done in any sequence and with any number of sectors (0 to 18). Refer to DQ3, Sector Erase Timer, in the Write Operation Status section.

Sector erase does *not* require the user to program the device prior to erase. The device automatically programs all memory locations in the sector(s) to be erased prior to electrical erase. When erasing a sector or sectors the remaining unselected sectors are not affected. The system is *not* required to provide any controls or timings during these operations.

The automatic sector erase begins after the 80 μ s time out from the rising edge of the \overline{WE} pulse for the last sector erase command pulse and terminates when the data on DQ7, \overline{Data} Polling, is “1” (see Write Operation Status section) at which time the device returns to the read mode. \overline{Data} Polling must be performed at an address within any of the sectors being erased.

Figure 2 illustrates the Embedded Erase Algorithm using typical command strings and bus operations.

Erase Suspend

The Erase Suspend command allows the user to interrupt a Sector Erase operation and then perform data

reads or programs to a sector not being erased. This command is applicable **ONLY** during the Sector Erase operation which includes the time-out period for sector erase. The Erase Suspend command will be ignored if written during the Chip Erase operation or Embedded Program Algorithm. Writing the Erase Suspend command during the Sector Erase time-out results in immediate termination of the time-out period and suspension of the erase operation.

Any other command written during the Erase Suspend mode will be ignored except the Erase Resume command. Writing the Erase Resume command resumes the erase operation. The addresses are “don’t-cares” when writing the Erase Suspend or Erase Resume command.

When the Erase Suspend command is written during a Sector Erase operation, the chip will take a maximum of 20 μ s to suspend the operation and go into erase suspended mode, at which time the user can read or program from a sector that is not being erased. Reading data in this mode is the same as reading from the standard read mode, except that the data must be read from sectors that have not been erase suspended. Successively reading from the erase-suspended sector while the device is in the erase-suspend-read mode will cause DQ2 to toggle. After entering the erase-suspend mode, the user can program the device by writing the appropriate command sequence for Byte Program. This program mode is known as the erase suspend-program mode. Again, programming in this mode is the same as programming in regular Byte Program mode, except that the data must be programmed to sectors that are not erase suspended. Successively reading from the erase suspended sector while the device is in the erase suspend-program mode will cause DQ2 to toggle. The end of the erase suspend-program operation is detected by the RY/ \overline{BY} output pin, \overline{DATA} Polling of DQ7, or by the Toggle Bit (DQ6), which is the same as the regular Byte Program operation. Note that DQ7 must be read from the Byte Program address while DQ6 can be read from any address.

When the erase operation has been suspended, the device defaults to the erase-suspend-read mode. Reading data in this mode is the same as reading from the standard read mode except that the data must be read from sectors that have not been erase-suspended.

To resume the operation of Sector Erase, the Resume command (30H) should be written. Any further writes of the Resume command at this point will be ignored. Another Erase Suspend command can be written after the chip has resumed erasing.

Write Operation Status

Table 8. Hardware Sequence Flags

	Status	DQ7	DQ6	DQ5	DQ3	DQ2	RDY/BSY	
In Progress	Byte Programming	$\overline{\text{DQ7}}$	Toggle	0	0	No Tog	0	
	Program/Erase in Auto-Erase	0	Toggle	0	1	(Note 1)	0	
	Erase suspend mode	Erase sector address	1	No Tog	0	1	Toggle	1
		Non-erase sector address	Data	Data	Data	Data	Data	1
	Program in erase suspend	$\overline{\text{DQ7}}$ (Note 2)	Toggle	0	1	1 (Note 1)	0	
Exceeded Time Limits	Byte Programming	$\overline{\text{DQ7}}$	Toggle	1	0	No Tog	0	
	Program/Erase in Auto-Erase	0	Toggle	1	1	(Note 3)	0	
	Program in erase suspend	$\overline{\text{DQ7}}$	Toggle	1	1	(Note 3)	0	

Notes:

1. DQ2 can be toggled when sector address applied is that of an erasing sector. Conversely, DQ2 cannot be toggled when the sector address applied is that of a non-erasing sector. DQ2 is therefore used to determine which sectors are erasing and which are not.
2. These status flags apply when outputs are read from the address of a non-erase-suspended sector.
3. If DQ5 is high (exceeded timing limits), successive reads from a problem sector will cause DQ2 to toggle.

DQ7: $\overline{\text{Data}}$ Polling

The Am29F800 device features $\overline{\text{Data}}$ Polling as a method to indicate to the host that the embedded algorithms are in progress or completed. During the Embedded Program Algorithm, an attempt to read the device will produce the complement of the data last written to DQ7. Upon completion of the Embedded Program Algorithm, an attempt to read the device will produce the true data last written to DQ7. During the Embedded Erase Algorithm, an attempt to read the device will produce a “0” at the DQ7 output. Upon completion of the Embedded Erase Algorithm an attempt to read the device will produce a “1” at the DQ7 output. The flowchart for $\overline{\text{Data}}$ Polling (DQ7) is shown in Figure 3.

For chip erase, the $\overline{\text{Data}}$ Polling is valid after the rising edge of the sixth $\overline{\text{WE}}$ pulse in the six write pulse sequence. For sector erase, the $\overline{\text{Data}}$ Polling is valid after the last rising edge of the sector erase $\overline{\text{WE}}$ pulse. $\overline{\text{Data}}$ Polling must be performed at sector addresses within any of the sectors being erased and **not** a protected sector. Otherwise, the status may not be valid.

Just prior to the completion of Embedded Algorithm operations DQ7 may change asynchronously while the output enable ($\overline{\text{OE}}$) is asserted low. This means that the device is driving status information on DQ7 at one instant of time and then that byte's valid data at the next instant of time. Depending on when the system samples the DQ7 output, it may read the status or valid data. Even if the device has completed

the Embedded Algorithm operations and DQ7 has a valid data, the data outputs on DQ0–DQ6 may be still invalid. The valid data on DQ0–DQ7 will be read on the successive read attempts.

The $\overline{\text{Data}}$ Polling feature is only active during the Embedded Programming Algorithm, Embedded Erase Algorithm, or sector erase time-out (see Table 7).

See Figure 11 for the $\overline{\text{Data}}$ Polling timing specifications and diagrams.

DQ6: Toggle Bit

The Am29F800 also features the “Toggle Bit” as a method to indicate to the host system that the embedded algorithms are in progress or completed.

During an Embedded Program or Erase Algorithm cycle, successive attempts to read ($\overline{\text{OE}}$ toggling) data from the device at any address will result in DQ6 toggling between one and zero. Once the Embedded Program or Erase Algorithm cycle is completed, DQ6 will stop toggling and valid data will be read on *the next* successive attempt. During programming, the Toggle Bit is valid after the rising edge of the fourth $\overline{\text{WE}}$ pulse in the four write pulse sequence. For chip erase, the Toggle Bit is valid after the rising edge of the sixth $\overline{\text{WE}}$ pulse in the six write pulse sequence. For Sector erase, the Toggle Bit is valid after the last rising edge of the sector erase $\overline{\text{WE}}$ pulse. The Toggle Bit is active during the sector erase time-out.

Either $\overline{\text{CE}}$ or $\overline{\text{OE}}$ toggling will cause DQ6 to toggle. In addition, an Erase Suspend/Resume command will

cause DQ6 to toggle. See Figure 12 for the Toggle Bit timing specifications and diagrams.

DQ5: Exceeded Timing Limits

DQ5 will indicate if the program or erase time has exceeded the specified limits (internal pulse count). Under these conditions DQ5 will produce a “1”. This is a failure condition which indicates that the program or erase cycle was not successfully completed. $\overline{\text{Data}}$ Polling is the only operating function of the device under this condition. The $\overline{\text{CE}}$ circuit will partially power down the device under these conditions (to approximately 2 mA). The $\overline{\text{OE}}$ and $\overline{\text{WE}}$ pins will control the output disable functions as described in Table 1.

The DQ5 failure condition will also appear if a user tries to program a 1 to a location that is previously programmed to 0. In this case the device locks out and never completes the Embedded Program Algorithm. Hence, the system never reads a valid data on DQ7 bit and DQ6 never stops toggling. Once the device has exceeded timing limits, the DQ5 bit will indicate a “1”. Please note that this is not a device failure condition since the device was incorrectly used. If this occurs, reset the device.

DQ3: Sector Erase Timer

After the completion of the initial sector erase command sequence the sector erase time-out will begin. DQ3 will remain low until the time-out is complete. $\overline{\text{Data}}$ Polling and Toggle Bit are valid after the initial sector erase command sequence.

If $\overline{\text{Data}}$ Polling or the Toggle Bit indicates the device has been written with a valid erase command, DQ3 may be used to determine if the sector erase timer window is still open. If DQ3 is high (“1”) the internally controlled erase cycle has begun; attempts to write subsequent commands (other than Erase Suspend) to the device will be ignored until the erase operation is completed as indicated by $\overline{\text{Data}}$ Polling or Toggle Bit. If DQ3 is low (“0”), the device will accept additional sector erase commands. To insure the command has been accepted, the system software should check the status of DQ3 prior to and following each subsequent sector erase command. If DQ3 were high on the second status check, the command may not have been accepted. Refer to Table 8, Hardware Sequence Flags.

DQ2: Toggle Bit 2

This toggle bit, along with DQ6, can be used to determine whether the device is in the Embedded Erase Algorithm or in Erase suspend.

Successive reads from the erasing sector will cause DQ2 to toggle during the Embedded Erase Algorithm. If the device is in the erase suspend-read mode, successive reads from the erase-suspend sector will cause DQ2 to toggle. When the device is in the erase suspend-program mode, successive reads from the

byte address of the non-erase suspend sector will indicate a logic “1” at the DQ2 bit. Note that a sector which is selected for erase is not available for read in Erase Suspend mode. Other sectors which are not selected for Erase can be read in Erase Suspend.

DQ6 is different from DQ2 in that DQ6 toggles only when the standard program or erase, or erase suspend-program operation is in progress.

If the DQ5 failure condition is observed while in Sector Erase mode (i.e., exceeded timing limits), the DQ2 toggle bit can give extra information. In this case, the normal function of DQ2 is modified. If DQ5 is at logic “1”, then DQ2 will toggle with consecutive reads only at the sector address that caused the failure condition. DQ2 will toggle at the sector address where the failure occurred and will not toggle at other sector addresses.

RY/ $\overline{\text{BY}}$: Ready/ $\overline{\text{Busy}}$

The Am29F800 provides a RY/ $\overline{\text{BY}}$ open-drain output pin as a way to indicate to the host system that the Embedded Algorithms are either in progress or have been completed. If the output is low, the device is busy with either a program or erase operation. If the output is high, the device is ready to accept any read/write or erase operation. When the RY/ $\overline{\text{BY}}$ pin is low, the device will not accept any additional program or erase commands with the exception of the Erase Suspend command. If the Am29F800 is placed in an Erase Suspend mode, the RY/ $\overline{\text{BY}}$ output will be high.

During programming, the RY/ $\overline{\text{BY}}$ pin is driven low after the rising edge of the fourth $\overline{\text{WE}}$ pulse. During an erase operation, the RY/ $\overline{\text{BY}}$ pin is driven low after the rising edge of the sixth $\overline{\text{WE}}$ pulse. The RY/ $\overline{\text{BY}}$ pin should be ignored while RESET is at V_{IL} . Refer to Figure 13 for a detailed timing diagram.

Since this is an open-drain output, several RY/ $\overline{\text{BY}}$ pins can be tied together in parallel with a pull-up resistor to V_{CC} .

RESET: Hardware Reset

The Am29F800 device may be reset by driving the RESET pin to V_{IL} . The $\overline{\text{RESET}}$ pin must be kept low (V_{IL}) for at least 500 ns. Any operation in progress will be terminated and the internal state machine will be reset to the read mode 20 μs after the RESET pin is driven low. Furthermore, once the RESET pin goes high, the device requires an additional 50 ns before it will allow read access. When the $\overline{\text{RESET}}$ pin is low, the device will be in the standby mode for the duration of the pulse and all the data output pins will be tri-stated. If a hardware reset occurs during a program or erase operation, the data at that particular location will be indeterminate.

The $\overline{\text{RESET}}$ pin may be tied to the system reset input. Therefore, if a system reset occurs during the Embedded Program or Erase Algorithm, the device

will be automatically reset to read mode and this will enable the system's microprocessor to read the boot-up firmware from the Flash memory.

Byte/Word Configuration

The $\overline{\text{BYTE}}$ pin selects the byte (8-bit) mode or word (16 bit) mode for the Am29F800 device. When this pin is driven high, the device operates in the word (16 bit) mode. The data is read and programmed at DQ0–DQ15. When this pin is driven low, the device operates in byte (8 bit) mode. Under this mode, the DQ15/A-1 pin becomes the lowest address bit and DQ8–DQ14 bits are tri-stated. However, the command bus cycle is always an 8-bit operation and hence commands are written at DQ0–DQ7 and the DQ8–DQ15 bits are ignored. Refer to Figures 15 and 16 for the timing diagram.

Data Protection

The Am29F800 is designed to offer protection against accidental erasure or programming caused by spurious system level signals that may exist during power transitions. During power up the device automatically resets the internal state machine in the Read mode. Also, with its control register architecture, alteration of the memory contents only occurs after successful completion of specific multi-bus cycle command sequences.

The device also incorporates several features to prevent inadvertent write cycles resulting from V_{CC} power-up and power-down transitions or system noise.

Low V_{CC} Write Inhibit

To avoid initiation of a write cycle during V_{CC} power-up and power-down, the Am29F800 locks out write cycles for $V_{CC} < V_{LKO}$ (see DC Characteristics section for voltages). When $V_{CC} < V_{LKO}$, the command register is disabled, all internal program/erase circuits are disabled, and the device resets to the read mode. The Am29F800 ignores all writes until $V_{CC} > V_{LKO}$. The user must ensure that the control pins are in the correct logic state when $V_{CC} > V_{LKO}$ to prevent unintentional writes.

Write Pulse “Glitch” Protection

Noise pulses of less than 5 ns (typical) on $\overline{\text{OE}}$, $\overline{\text{CE}}$, or $\overline{\text{WE}}$ will not initiate a write cycle.

Logical Inhibit

Writing is inhibited by holding any one of $\overline{\text{OE}} = V_{IL}$, $\overline{\text{CE}} = V_{IH}$, or $\overline{\text{WE}} = V_{IH}$. To initiate a write cycle $\overline{\text{CE}}$ and $\overline{\text{WE}}$ must be a logical zero while $\overline{\text{OE}}$ is a logical one.

Power-Up Write Inhibit

Power-up of the device with $\overline{\text{WE}} = \overline{\text{CE}} = V_{IL}$ and $\overline{\text{OE}} = V_{IH}$ will not accept commands on the rising edge of $\overline{\text{WE}}$. The internal state machine is automatically reset to the read mode on power-up.

EMBEDDED ALGORITHMS

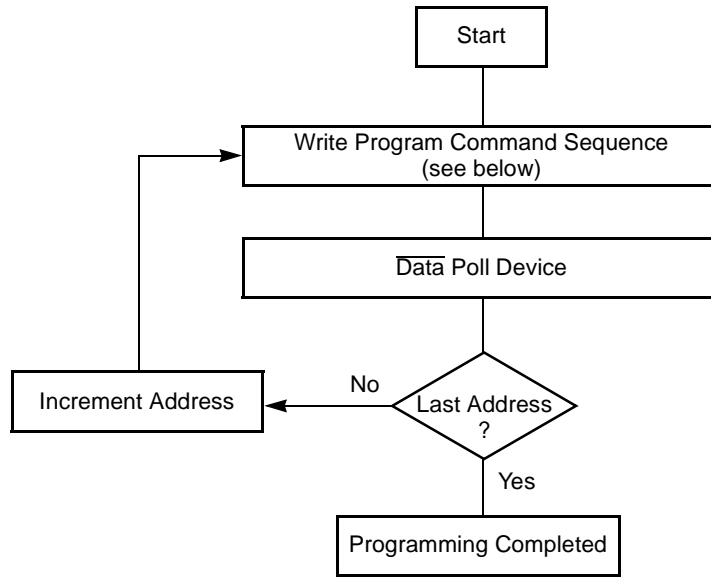

Program Command Sequence (Address/Command):

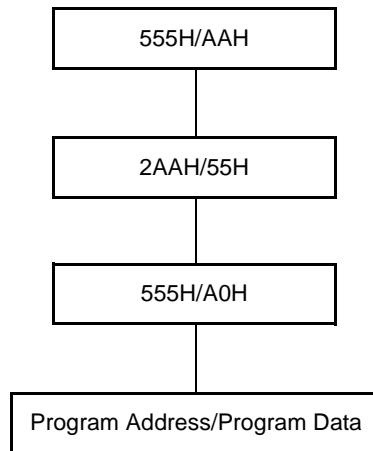

20375C-6

Figure 1. Embedded Programming Algorithm

EMBEDDED ALGORITHMS

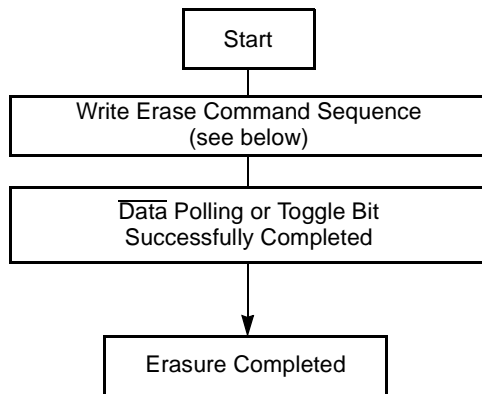

Chip Erase Command Sequence
(Address/Command):

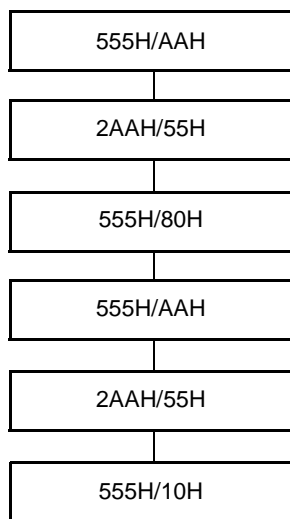

Individual Sector/Multiple Sector
Erase Command Sequence
(Address/Command):

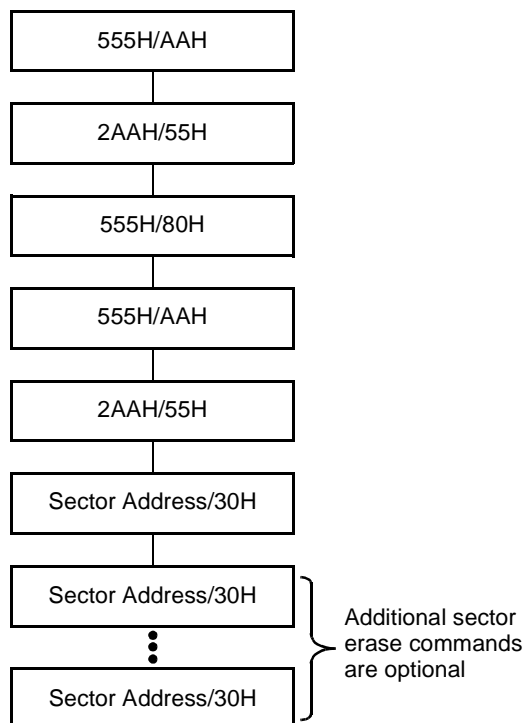

20375C-7

Note:

1. To insure the command has been accepted, the system software should check the status of DQ3 prior to and following each subsequent sector erase command. If DQ3 were high on the second status check, the command may not have been accepted.

Figure 2. Embedded Erase Algorithm

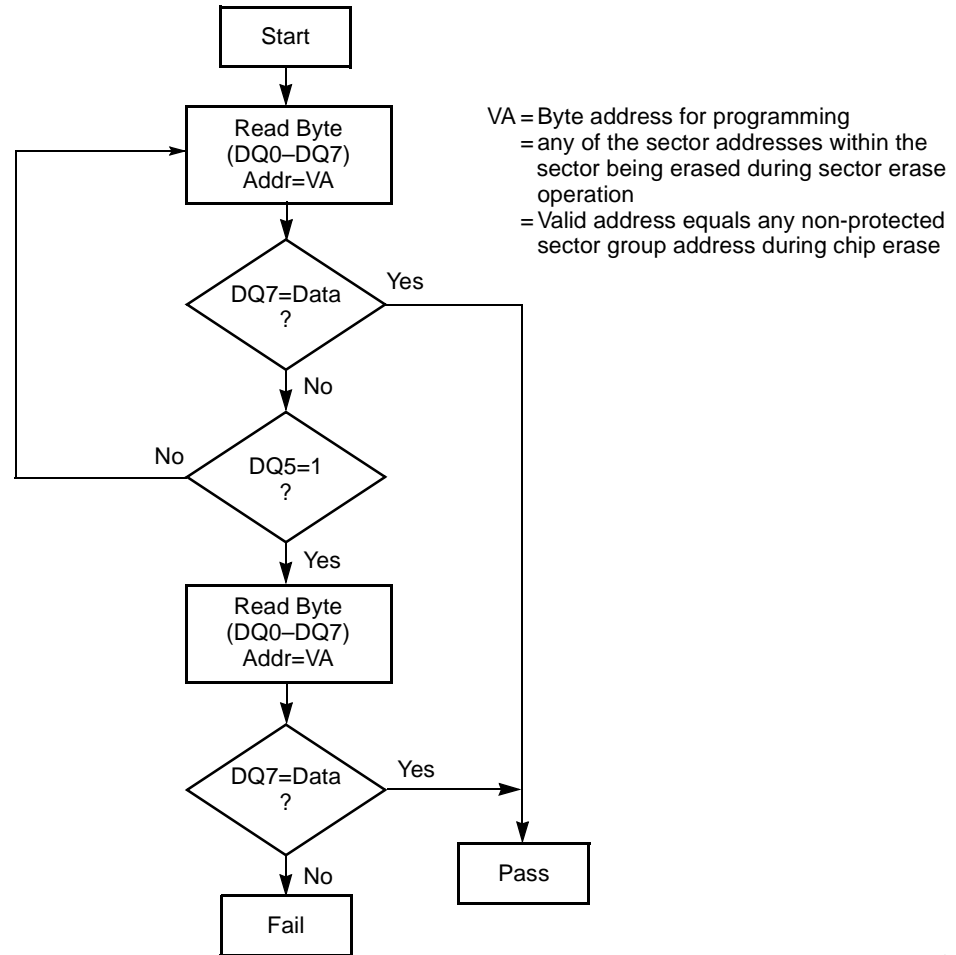

20375C-8

Note:

1. DQ7 is rechecked even if DQ5 = "1" because DQ7 may change simultaneously with DQ5.

Figure 3. Data Polling Algorithm

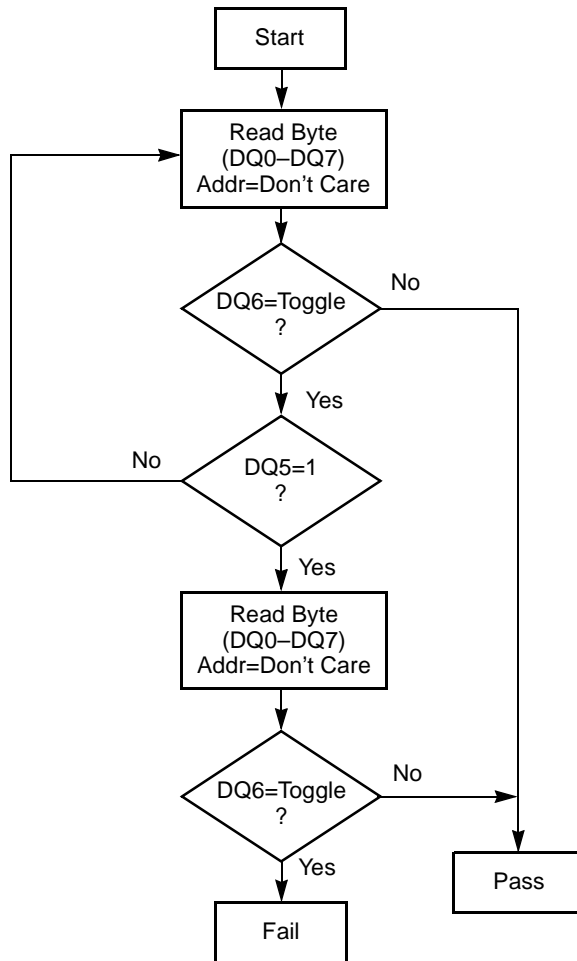

20375C-9

Note:

1. DQ6 is rechecked even if DQ5 = "1" because DQ6 may stop toggling at the same time as DQ5 changing to "1".

Figure 4. Toggle Bit Algorithm

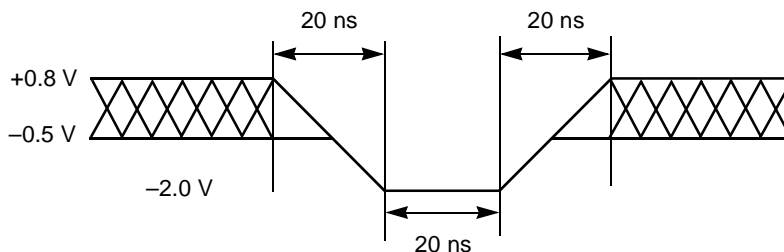

20375C-10

Figure 5. Maximum Negative Overshoot Waveform

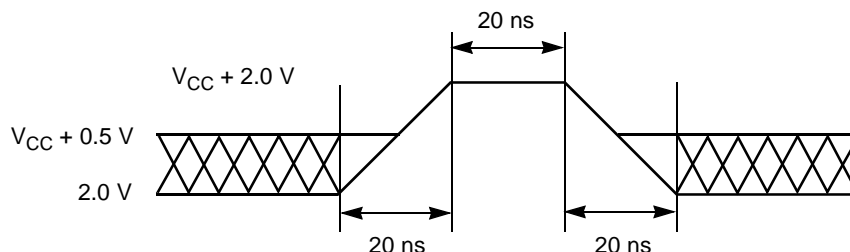

20375C-11

Figure 6. Maximum Positive Overshoot Waveform

ABSOLUTE MAXIMUM RATINGS

Storage Temperature	
Plastic Packages	–65°C to +125°C
Ambient Temperature	
with Power Applied	–55°C to +125°C
Voltage with Respect to Ground	
All pins except A9 (Note 1)	–2.0 V to +7.0 V
V _{CC} (Note 1)	–2.0 V to +7.0 V
A9 (Note 2)	–2.0 V to +13.0 V
Output Short Circuit Current (Note 3)	200 mA

Notes:

1. Minimum DC voltage on input or I/O pins is –0.5 V. During voltage transitions, inputs may overshoot V_{SS} to –2.0 V for periods of up to 20 ns. Maximum DC voltage on input and I/O pins is V_{CC} + 0.5 V. During voltage transitions, input and I/O pins may overshoot to V_{CC} + 2.0 V for periods up to 20 ns.
2. Minimum DC input voltage on A9 pin is –0.5 V. During voltage transitions, A9 may overshoot V_{SS} to –2.0 V for periods of up to 20 ns. Maximum DC input voltage on A9 is +12.5 V which may overshoot to 14.0 V for periods up to 20 ns.
3. No more than one output shorted to ground at a time. Duration of the short circuit should not be greater than one second.

Stresses above those listed under “Absolute Maximum Ratings” may cause permanent damage to the device. This is a stress rating only; functional operation of the device at these or any other conditions above those indicated in the operational sections of this specification is not implied. Exposure of the device to absolute maximum rating conditions for extended periods may affect device reliability.

OPERATING RANGES**Commercial (C) Devices**

Ambient Temperature (T_A) 0°C to +70°C

Industrial (I) Devices

Ambient Temperature (T_A) –40°C to +85°C

Extended (E) Devices

Ambient Temperature (T_A) –55°C to +125°C

V_{CC} Supply Voltages

V_{CC} for Am29F800T/B-70, 90,

120, 150 +4.50 V to +5.50 V

Operating ranges define those limits between which the functionality of the device is guaranteed.

DC CHARACTERISTICS

TTL/NMOS Compatible

Parameter Symbol	Parameter Description	Test Conditions	Min	Max	Unit
I_{LI}	Input Load Current	$V_{IN} = V_{SS}$ to V_{CC} , $V_{CC} = V_{CC}$ Max		± 1.0	μA
I_{LIT}	A9 Input Load Current	$V_{CC} = V_{CC}$ Max, A9 = 13.0 V		35	μA
I_{LO}	Output Leakage Current	$V_{OUT} = V_{SS}$ to V_{CC} , $V_{CC} = V_{CC}$ Max		± 1.0	μA
I_{CC1}	V_{CC} Active Current (Note 1)	$\overline{CE} = V_{IL}$, $\overline{OE} = V_{IH}$	Byte	40	mA
			Word	50	
I_{CC2}	V_{CC} Active Current (Notes 2, 3)	$\overline{CE} = V_{IL}$, $\overline{OE} = V_{IH}$		60	mA
I_{CC3}	V_{CC} Standby Current	$V_{CC} = V_{CC}$ Max, $\overline{CE} = V_{IH}$, $\overline{OE} = V_{IL}$		1.0	mA
V_{IL}	Input Low Voltage		-0.5	0.8	V
V_{IH}	Input High Voltage		2.0	$V_{CC} + 0.5$	V
V_{ID}	Voltage for Autoselect and Temporary Sector Unprotect	$V_{CC} = 5.25$ Volt	10.5	13.0	V
V_{OL}	Output Low Voltage	$I_{OL} = 5.8$ mA, $V_{CC} = V_{CC}$ Min		0.45	V
V_{OH}	Output High Voltage	$I_{OH} = -2.5$ mA, $V_{CC} = V_{CC}$ Min	2.4		V
V_{LKO}	Low V_{CC} Lock-Out Voltage		3.2	4.2	V

Notes:

1. The I_{CC} current listed includes both the DC operating current and the frequency dependent component (at 6 MHz). The frequency component typically is less than 2 mA/MHz, with \overline{OE} at V_{IH} .
2. I_{CC} active while Embedded Program or Erase Algorithm is in progress.
3. Not 100% tested.

DC CHARACTERISTICS (Continued)

CMOS Compatible

Parameter Symbol	Parameter Description	Test Conditions	Min	Typ	Max	Unit
I_{LI}	Input Load Current	$V_{IN} = V_{SS}$ to V_{CC} , $V_{CC} = V_{CC}$ Max			± 1.0	μA
I_{LIT}	A9 Input Load Current	$V_{CC} = V_{CC}$ Max, A9 = 13.0 V			35	μA
I_{LO}	Output Leakage Current	$V_{OUT} = V_{SS}$ to V_{CC} , $V_{CC} = V_{CC}$ Max			± 1.0	μA
I_{CC1}	V_{CC} Active Current (Note 1)	$\overline{CE} = V_{IL}$, $\overline{OE} = V_{IH}$	Byte	20	40	mA
			Word	28	50	
I_{CC2}	V_{CC} Active Current (Notes 2, 3)	$\overline{CE} = V_{IL}$, $\overline{OE} = V_{IH}$		30	50	mA
I_{CC3}	V_{CC} Standby Current (Note 4)	$V_{CC} = V_{CC}$ Max, $\overline{CE} = V_{CC} \pm 0.3$ V, $\overline{OE} = V_{IL}$, $\overline{RESET} = V_{CC} \pm 0.3$ V		1	5	μA
V_{IL}	Input Low Voltage		-0.5		0.8	V
V_{IH}	Input High Voltage		$0.7 \times V_{CC}$		$V_{CC} + 0.3$	V
V_{ID}	Voltage for Autoselect and Temporary Sector Unprotect	$V_{CC} = 5.25$ Volt	10.5		13.0	V
V_{OL}	Output Low Voltage	$I_{OL} = 5.8$ mA, $V_{CC} = V_{CC}$ Min			0.45	V
V_{OH1}	Output Low Voltage	$I_{OH} = -2.5$ mA, $V_{CC} = V_{CC}$ Min	$0.85 V_{CC}$			V
V_{OH2}		$I_{OH} = -100$ μA , $V_{CC} = V_{CC}$ Min	$V_{CC} - 0.4$			V
V_{LKO}	Low V_{CC} Lock-Out Voltage		3.2		4.2	V

Notes:

- The I_{CC} current listed includes both the DC operating current and the frequency dependent component (at 6 MHz). The frequency component typically is less than 2 mA/MHz, with \overline{OE} at V_{IH} .
- I_{CC} active while Embedded Program or Erase Algorithm is in progress.
- Not 100% tested.
- $I_{CC3} = 20 \mu A$ max at extended temperatures ($>+85^{\circ}C$)

AC CHARACTERISTICS

Read-only Operations Characteristics

Parameter Symbols		Description	Test Setup	Speed Options (Notes 1 and 2)				Unit	
JEDEC	Standard			-70	-90	-120	-150		
t_{AVAV}	t_{RC}	Read Cycle Time (Note 4)	Min	70	90	120	150	ns	
t_{AVQV}	t_{ACC}	Address to Output Delay	$\overline{CE} = V_{IL}$	Max	70	90	120	150	ns
			$\overline{OE} = V_{IL}$						
t_{ELQV}	t_{CE}	Chip Enable to Output Delay	$\overline{OE} = V_{IL}$	Max	70	90	120	150	ns
t_{GLQV}	t_{OE}	Output Enable to Output Delay		Max	30	35	50	55	ns
t_{EHQZ}	t_{DF}	Chip Enable to Output High Z (Notes 3, 4)		Max	20	20	30	35	ns
t_{GHQZ}	t_{DF}	Output Enable to Output High Z (Notes 3, 4)		Max	20	20	30	35	ns
t_{AXQX}	t_{OH}	Output Hold Time From Addresses, \overline{CE} , or \overline{OE} , Whichever Occurs First		Min	0	0	0	0	ns
	t_{Ready}	\overline{RESET} Pin Low to Read Mode (Note 4)		Max	20	20	20	20	μs
	t_{ELFL}	\overline{CE} to \overline{BYTE} Switching Low or High		Max	5	5	5	5	ns
	t_{ELFH}								
	t_{FLQZ}	\overline{BYTE} Switching Low to Output High Z (Note 3)		Max	20	30	30	30	ns

Notes:

1. Test Conditions (for -70 only):
 Output Load: 1 TTL gate and 30 pF
 Input rise and fall times: 5 ns
 Input pulse levels: 0.0 V to 3.0 V
 Timing measurement reference level
 input and output voltage: 1.5 V

2. Test Conditions (for all others):
 Output Load: 1 TTL gate and 100 pF
 Input rise and fall times: 20 ns
 Input pulse levels: 0.45 V to 2.4 V
 Timing measurement reference level, input and output voltages:
 0.8 V and 2.0 V

3. Output driver disable time.
4. Not 100% tested.

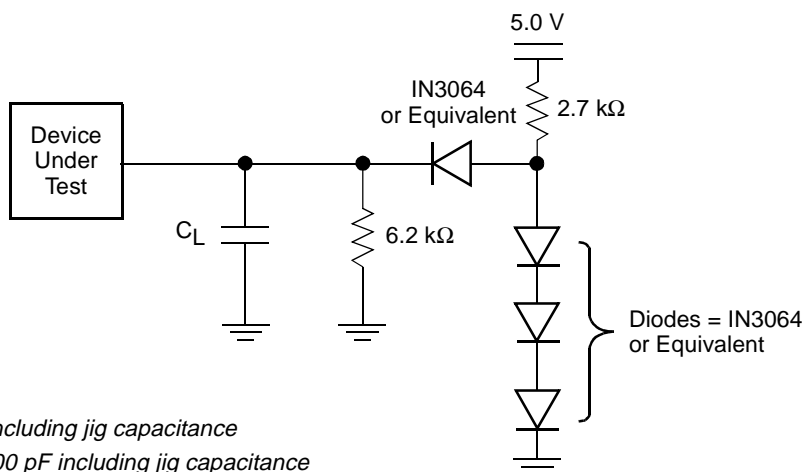

Notes:

- For -70: $C_L = 30$ pF including jig capacitance
 For all others: $C_L = 100$ pF including jig capacitance

Figure 7. Test Conditions

20375C-12

AC CHARACTERISTICS

Write/Erase/Program Operations

Parameter Symbols		Description		-70	-90	-120	-150	Unit
JEDEC	Standard							
t_{AVAV}	t_{WC}	Write Cycle Time (Note 2)	Min	70	90	120	150	ns
t_{AVWL}	t_{AS}	Address Setup Time	Min	0	0	0	0	ns
t_{WLAX}	t_{AH}	Address Hold Time	Min	45	45	50	50	ns
t_{DVWH}	t_{DS}	Data Setup Time	Min	30	45	50	50	ns
t_{WHDX}	t_{DH}	Data Hold Time	Min	0	0	0	0	ns
	t_{OEHL}	Output Enable Hold Time						
		Read (Note 2)	Min	0	0	0	0	ns
		Toggle and $\overline{\text{Data}}$ Polling (Note 2)	Min	10	10	10	10	ns
t_{GHWL}	t_{GHWL}	Read Recover Time Before Write ($\overline{\text{OE}}$ High to $\overline{\text{WE}}$ Low)	Min	0	0	0	0	ns
t_{ELWL}	t_{CS}	$\overline{\text{CE}}$ Setup Time	Min	0	0	0	0	ns
t_{WHEH}	t_{CH}	$\overline{\text{CE}}$ Hold Time	Min	0	0	0	0	ns
t_{WLWH}	t_{WP}	Write Pulse Width	Min	35	45	50	50	ns
t_{WHWL}	t_{WPH}	Write Pulse Width High	Min	20	20	20	20	ns
t_{WHWH1}	t_{WHWH1}	Byte Programming Operation	Typ	7	7	7	7	μs
t_{WHWH2}	t_{WHWH2}	Sector Erase Operation (Note 1)	Typ	1	1	1	1	sec
			Max	8	8	8	8	sec
	t_{VCS}	V_{CC} Set Up Time (Note 2)	Min	50	50	50	50	μs
	t_{VIDR}	Rise Time to V_{ID}	Min	500	500	500	500	ns
	t_{RP}	RESET Pulse Width	Min	500	500	500	500	ns
	t_{BUSY}	Program/Erase Valid to $\text{RY}/\overline{\text{BY}}$ Delay (Note 2)	Min	30	35	50	55	ns
	t_{RSP}	RESET Setup Time for Temporary Sector Unprotect (Notes 2, 3)	Min	4	4	4	4	μs

Notes:

1. This does not include the preprogramming time.
2. Not 100% tested.
3. These timings are for Temporary Sector Unprotect operation.
4. Output Driver Disable Time.

KEY TO SWITCHING WAVEFORMS

WAVEFORM	INPUTS	OUTPUTS
	Must Be Steady	Will Be Steady
	May Change from H to L	Will Be Changing from H to L
	May Change from L to H	Will Be Changing from L to H
	Don't Care, Any Change Permitted	Changing, State Unknown
	Does Not Apply	Center Line is High-Impedance "Off" State

KS000010

SWITCHING WAVEFORMS

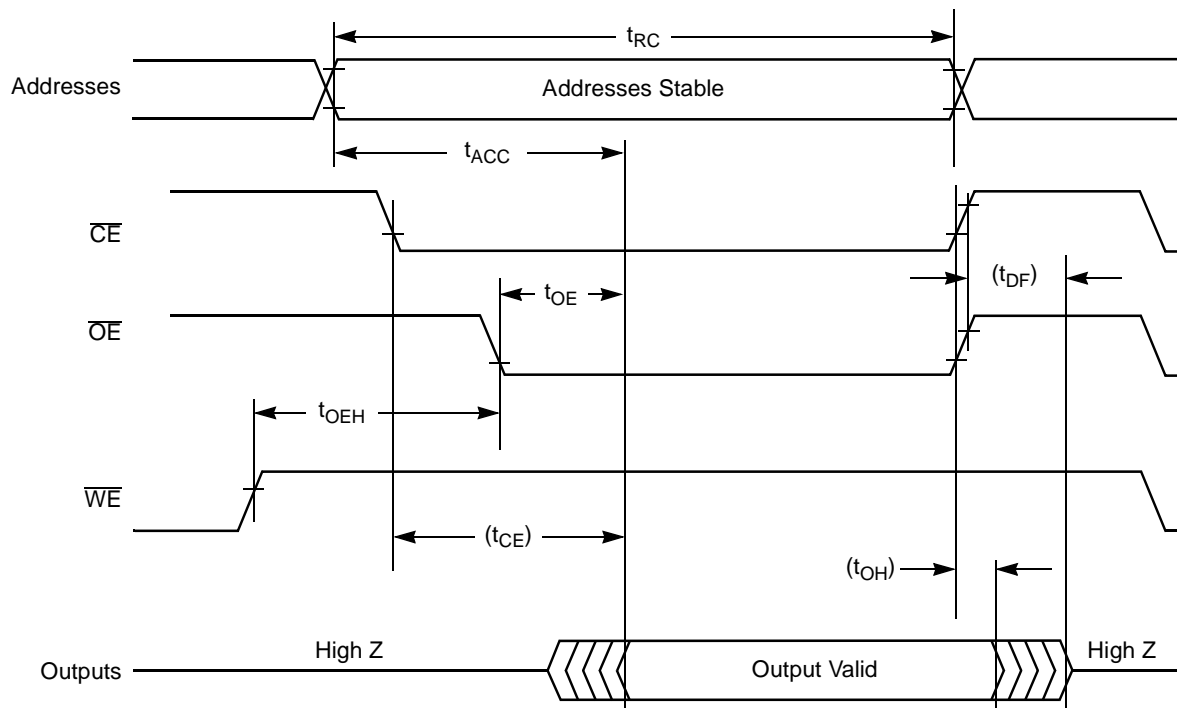

20375C-13

Figure 8. AC Waveforms for Read Operations

SWITCHING WAVEFORMS

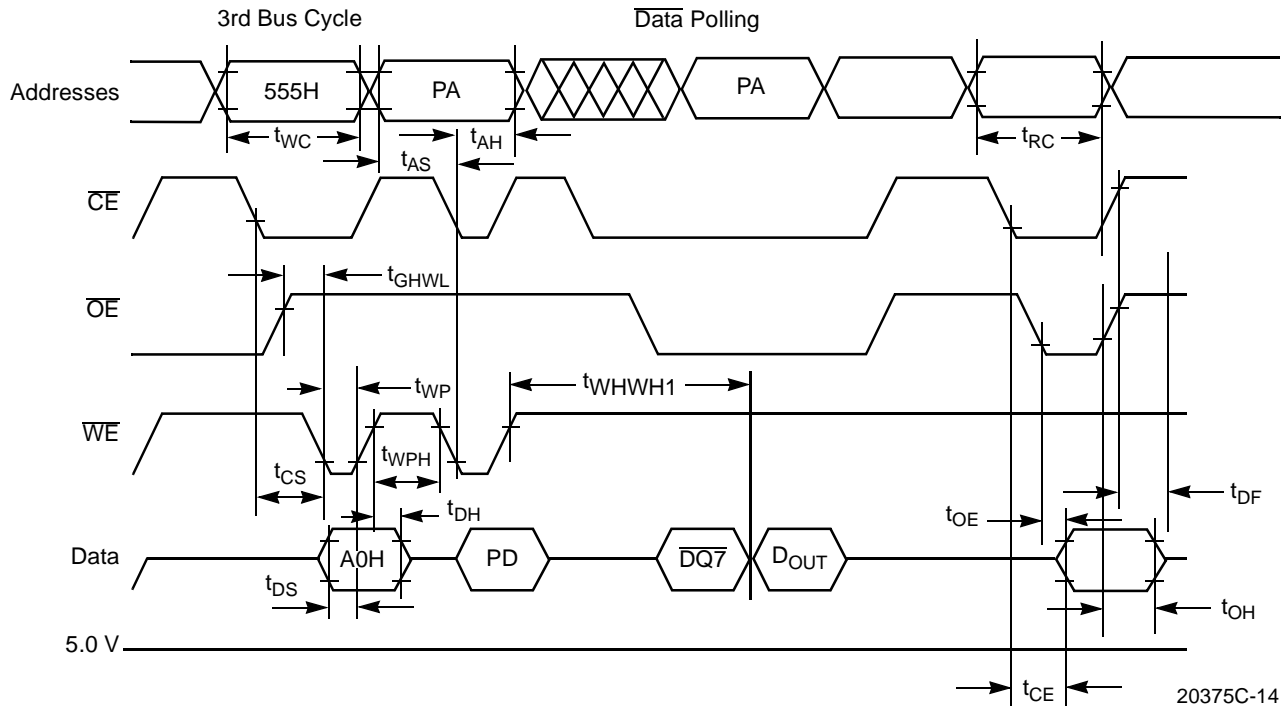

20375C-14

Notes:

1. PA is address of the memory location to be programmed.
2. PD is data to be programmed at byte address.
3. $\overline{DQ7}$ is the output of the complement of the data written to the device.
4. D_{OUT} is the output of the data written to the device.
5. Figure indicates last two bus cycles of four bus cycle sequence.
6. These waveforms are for the x16 mode.

Figure 9. Program Operation Timings

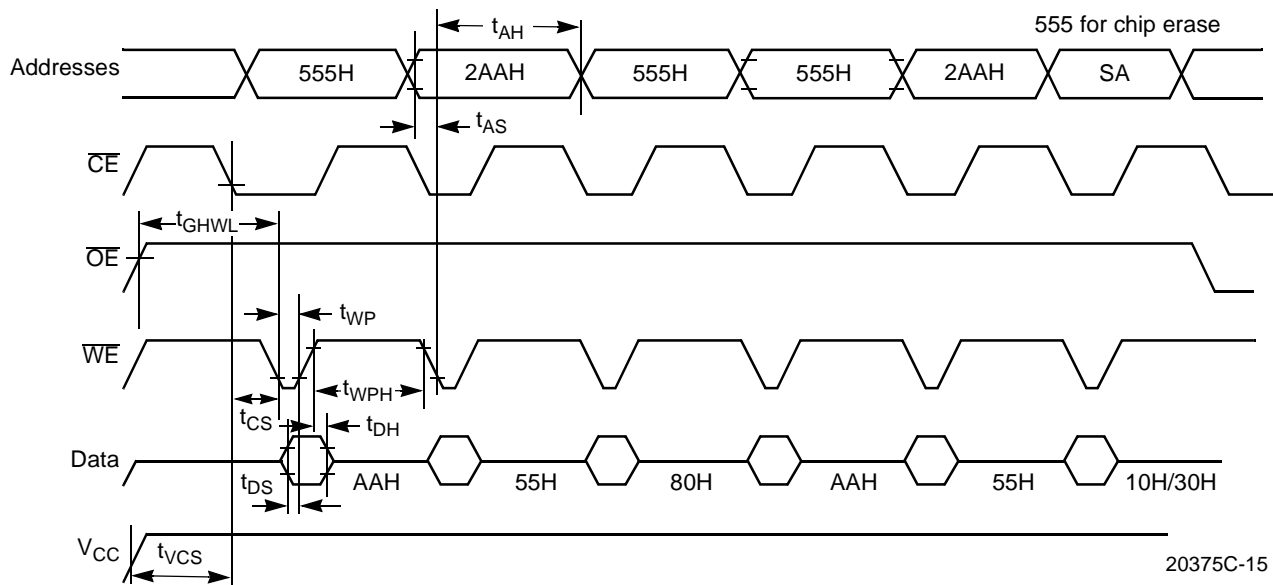

20375C-15

Notes:

1. SA is the sector address for Sector Erase.
2. These waveforms are for the x16 mode.

Figure 10. AC Waveforms Chip/Sector Erase Operations

SWITCHING WAVEFORMS

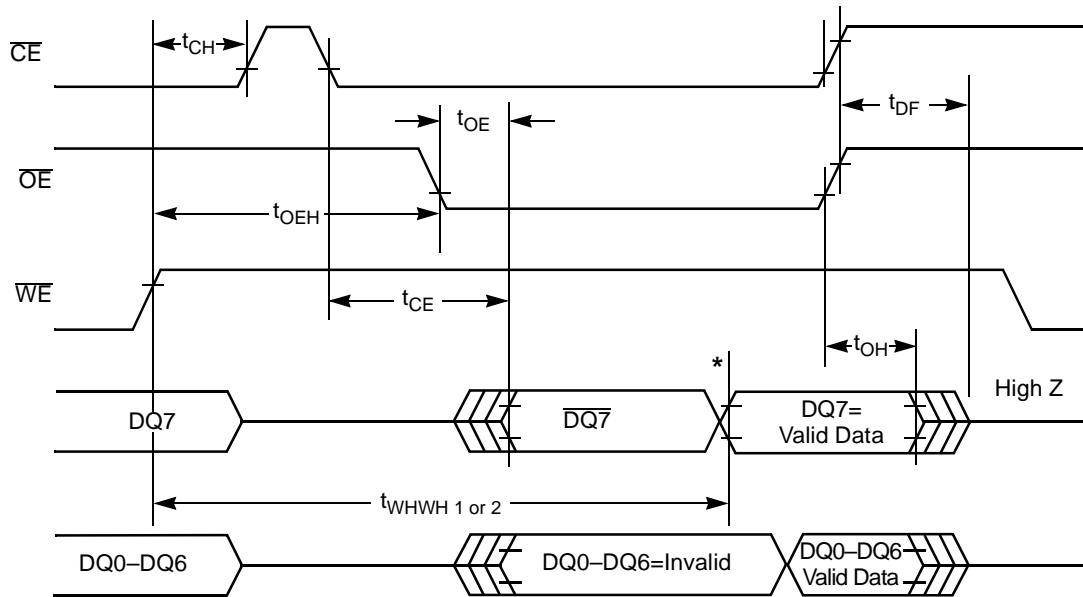

20375C-16

Note:

*DQ7=Valid Data (The device has completed the Embedded operation).

Figure 11. AC Waveforms for Data Polling During Embedded Algorithm Operations

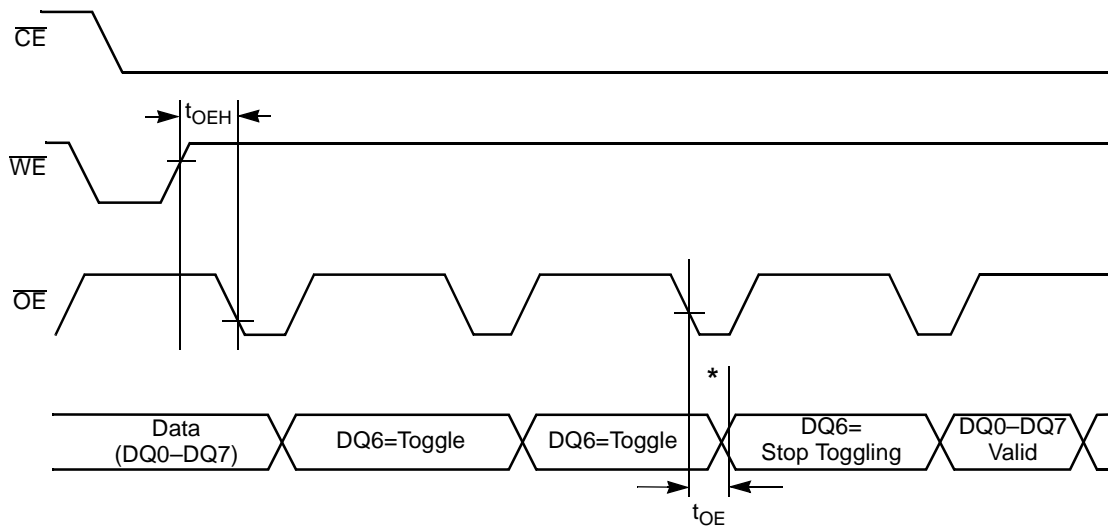

20375C-17

Note:

*DQ6 stops toggling (The device has completed the Embedded operation).

Figure 12. AC Waveforms for Toggle Bit During Embedded Algorithm Operations

SWITCHING WAVEFORMS

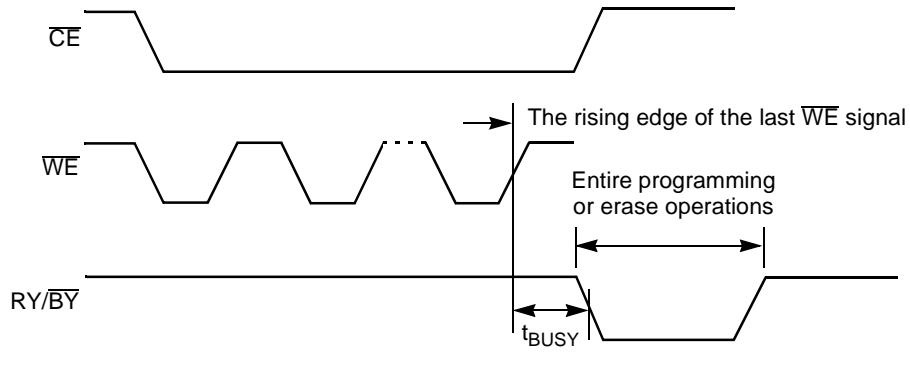

20375C-18

Figure 13. $\overline{RY/BY}$ Timing Diagram During Program/Erase Operations

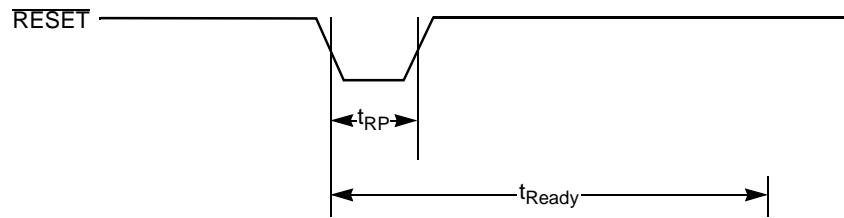

20375C-19

Figure 14. \overline{RESET} Timing Diagram

SWITCHING WAVEFORMS

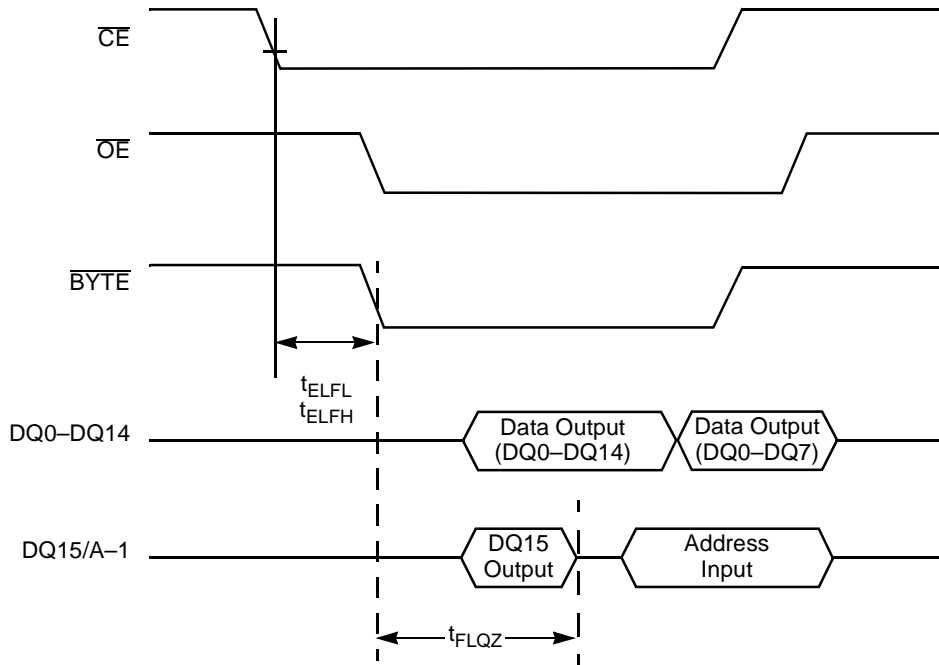

20375C-20

Figure 15. \overline{BYTE} Timing Diagram for Read Operation

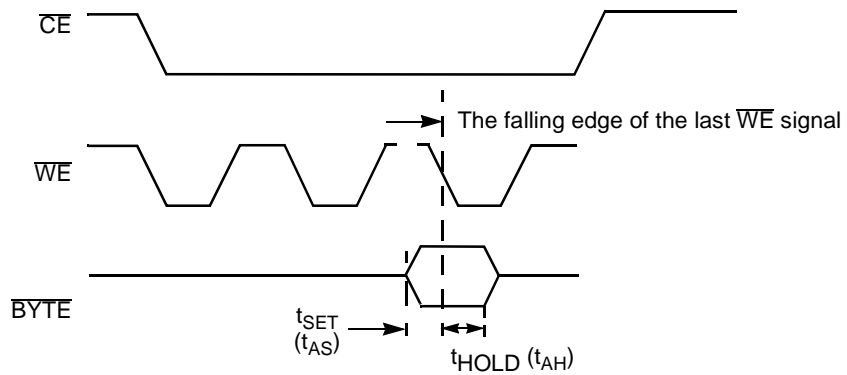

20375C-21

Figure 16. \overline{BYTE} Timing Diagram for Write Operations

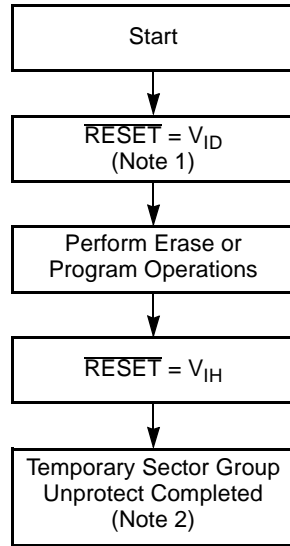

20375C-22

Notes:

1. All protected sectors unprotected.
2. All previously protected sectors are protected once again.

Figure 17. Temporary Sector Unprotect Algorithm

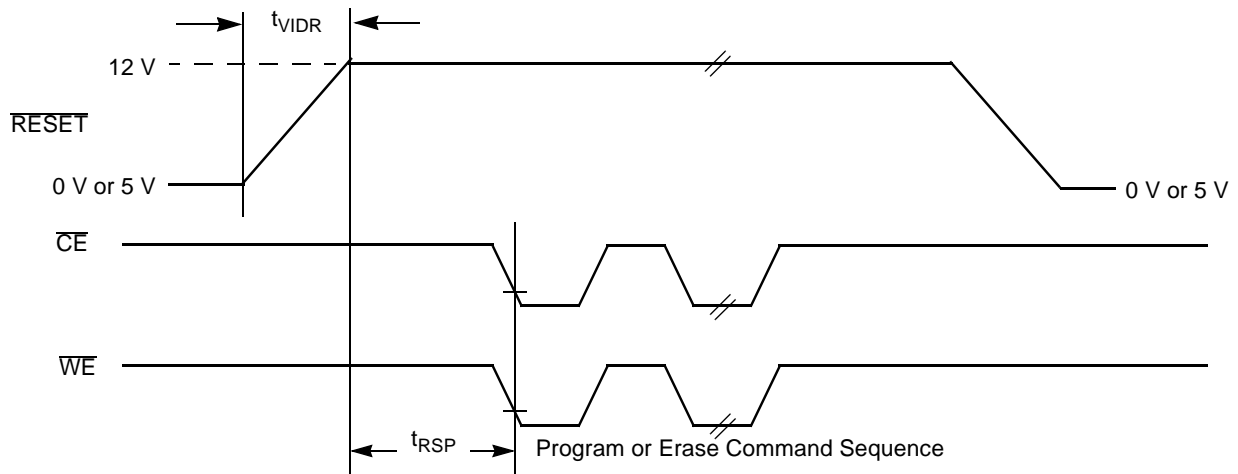

20375C-23

Figure 18. Temporary Sector Unprotect Timing Diagram

AC CHARACTERISTICS

Write/Erase/Program Operations

Alternate \overline{CE} Controlled Writes

Parameter Symbols		Description		-70	-90	-120	-150	Unit
JEDEC	Standard							
t_{AVAV}	t_{WC}	Write Cycle Time (Note 2)	Min	70	90	120	150	ns
t_{AVEL}	t_{AS}	Address Setup Time	Min	0	0	0	0	ns
t_{ELAX}	t_{AH}	Address Hold Time	Min	45	45	50	50	ns
t_{DVEH}	t_{DS}	Data Setup Time	Min	30	45	50	50	ns
t_{EHDX}	t_{DH}	Data Hold Time	Min	0	0	0	0	ns
	t_{OES}	Output Enable Setup Time	Min	0	0	0	0	ns
	t_{OEHL}	Output Enable Read (Note 2)	Min	0	0	0	0	ns
		Output Enable Hold Time Toggle and \overline{Data} Polling (Note 2)	Min	10	10	10	10	ns
t_{GHLEL}	t_{GHLEL}	Read Recover Time Before Write	Min	0	0	0	0	ns
t_{WLEL}	t_{WS}	\overline{WE} Setup Time	Min	0	0	0	0	ns
t_{EHWH}	t_{WH}	\overline{WE} Hold Time	Min	0	0	0	0	ns
t_{ELEH}	t_{CP}	\overline{CE} Pulse Width	Min	35	45	50	50	ns
t_{EHEL}	t_{CPH}	\overline{CE} Pulse Width High	Min	20	20	20	20	ns
t_{WHWH1}	t_{WHWH1}	Byte Programming Operation	Typ	7	7	7	7	μ s
		Word Programming Operation	Typ	14	14	14	14	μ s
t_{WHWH2}	t_{WHWH2}	Sector Erase Operation (Note 1)	Typ	1	1	1	1	sec
			Max	8	8	8	8	sec
	t_{FLQZ}	BYTE Switching Low to Output High Z (Note 2)	Max	20	30	30	30	ns

Notes:

1. This does not include the preprogramming time.
2. Not 100% tested.

SWITCHING WAVEFORM

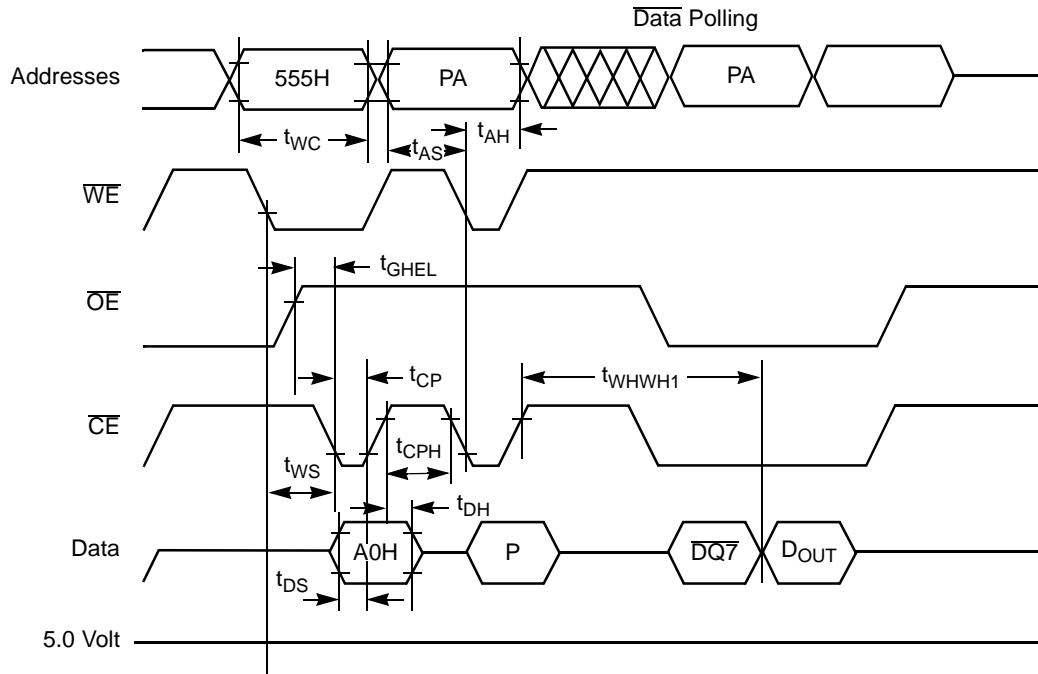

20375C-24

Notes:

1. PA is address of the memory location to be programmed.
2. PD is data to be programmed at byte address.
3. $\overline{DQ7}$ is the output of the complement of the data written to the device.
4. D_{OUT} is the output of the data written to the device.
5. Figure indicates last two bus cycles of four bus cycle sequence.
6. These waveforms are for the x16 mode.

Figure 19. Alternate \overline{CE} Controlled Program Operation Timings

ERASE AND PROGRAMMING PERFORMANCE

Parameter	Limits		Unit	Comments
	Typ (Note 1)	Max (Note 2)		
Sector Erase Time	1.0	8	sec	Excludes 00H programming prior to erasure
Chip Erase Time (Note 3)	19	152	sec	
Byte Programming Time (Note 5)	7	300	μ s	Excludes system-level overhead (Note 4)
Word Programming Time (Note 5)	14	600	μ s	
Chip Programming Time (Notes 3, 5)	7.2	21.6	sec	
Erase/Program Endurance	1,000,000		cycles	Minimum 100,000 cycles guaranteed

Notes:

1. The typical erase and programming times assume the following conditions: 25°C, 5.0 volt V_{CC} , 100,000 cycles. These conditions do not apply to erase/program endurance. Programming typicals assume checkerboard pattern.
2. The maximum erase and programming times assume the following conditions: 90°C, 4.5 volt V_{CC} , 100,000 cycles.
3. Although Embedded Algorithms allow for longer chip program and erase time, the actual time will be considerably less since bytes program or erase significantly faster than the worst case byte.
4. System-level overhead is defined as the time required to execute the four bus cycle command necessary to program each byte. In the preprogramming step of the Embedded Erase algorithm, all bytes are programmed to 00H before erasure.
5. The Embedded Algorithms allow for 2.5 ms byte program time. DQ5 = "1" only after a byte takes the theoretical maximum time to program. A minimal number of bytes may require significantly more programming pulses than the typical byte. The majority of the bytes will program within one or two pulses. This is demonstrated by the Typical and Maximum Programming Times listed above.

LATCHUP CHARACTERISTICS

	Min	Max
Input Voltage with respect to V_{SS} on all I/O pins	-1.0 V	$V_{CC} + 1.0$ V
V_{CC} Current	-100 mA	+100 mA

Includes all pins except V_{CC} . Test conditions: $V_{CC} = 5.0$ V, one pin at a time.

TSOP PIN CAPACITANCE

Parameter Symbol	Parameter Description	Test Setup	Typ	Max	Unit
C_{IN}	Input Capacitance	$V_{IN} = 0$	6	7.5	pF
C_{OUT}	Output Capacitance	$V_{OUT} = 0$	8.5	12	pF
C_{IN2}	Control Pin Capacitance	$V_{IN} = 0$	8	10	pF

Notes:

1. Sampled, not 100% tested.
2. Test conditions $T_A = 25^\circ\text{C}$, $f = 1.0\text{ MHz}$.

SO PIN CAPACITANCE

Parameter Symbol	Parameter Description	Test Setup	Typ	Max	Unit
C_{IN}	Input Capacitance	$V_{IN} = 0$	6	7.5	pF
C_{OUT}	Output Capacitance	$V_{OUT} = 0$	8.5	12	pF
C_{IN2}	Control Pin Capacitance	$V_{PP} = 0$	8	10	pF

Notes:

1. Sampled, not 100% tested.
2. Test conditions $T_A = 25^\circ\text{C}$, $f = 1.0\text{ MHz}$.

DATA RETENTION

Parameter	Test Conditions	Min	Unit
Minimum Pattern Data Retention Time	150°C	10	Years
	125°C	20	Years

PHYSICAL DIMENSIONS

TS 048

48-Pin Standard Thin Small Outline Package (measured in millimeters)

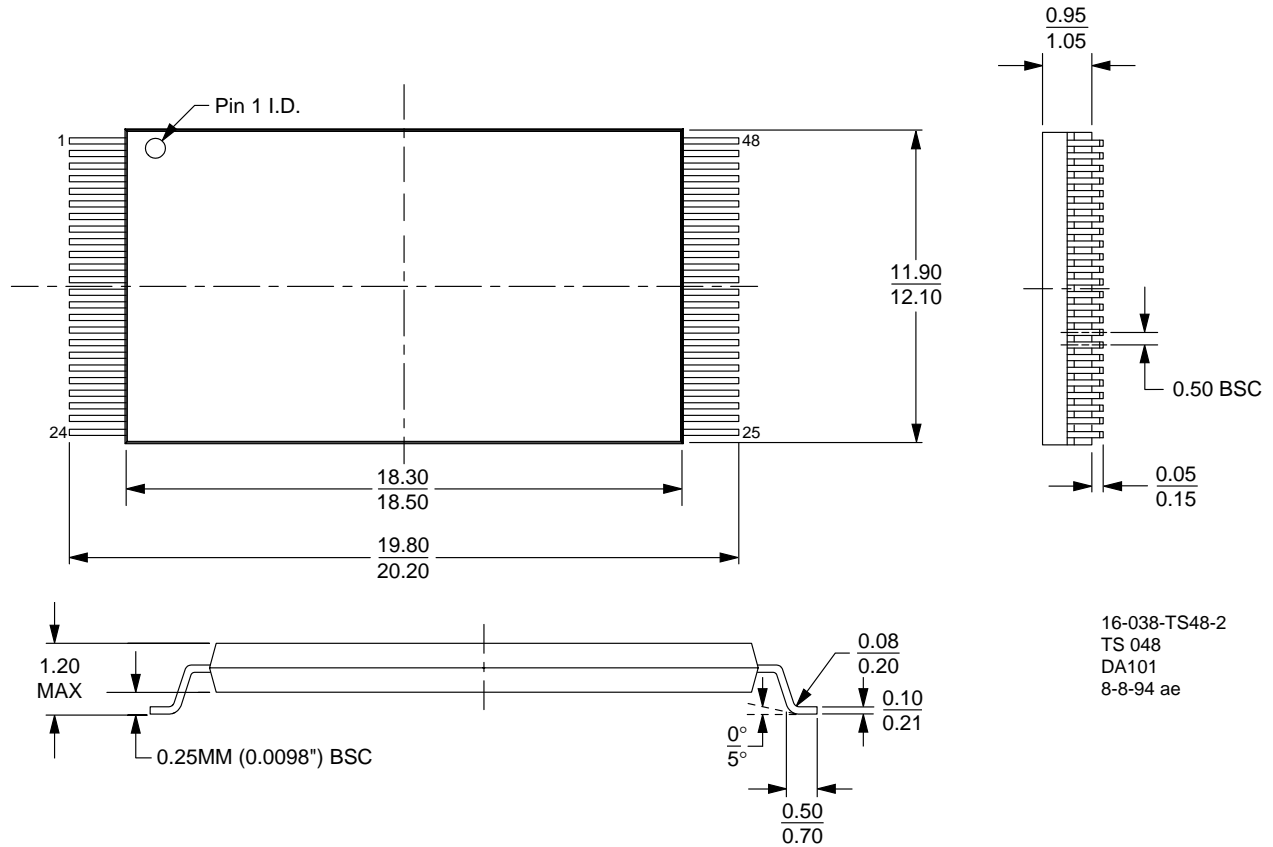

PHYSICAL DIMENSIONS (continued)

TSR048

48-Pin Reversed Thin Small Outline Package (measured in millimeters)

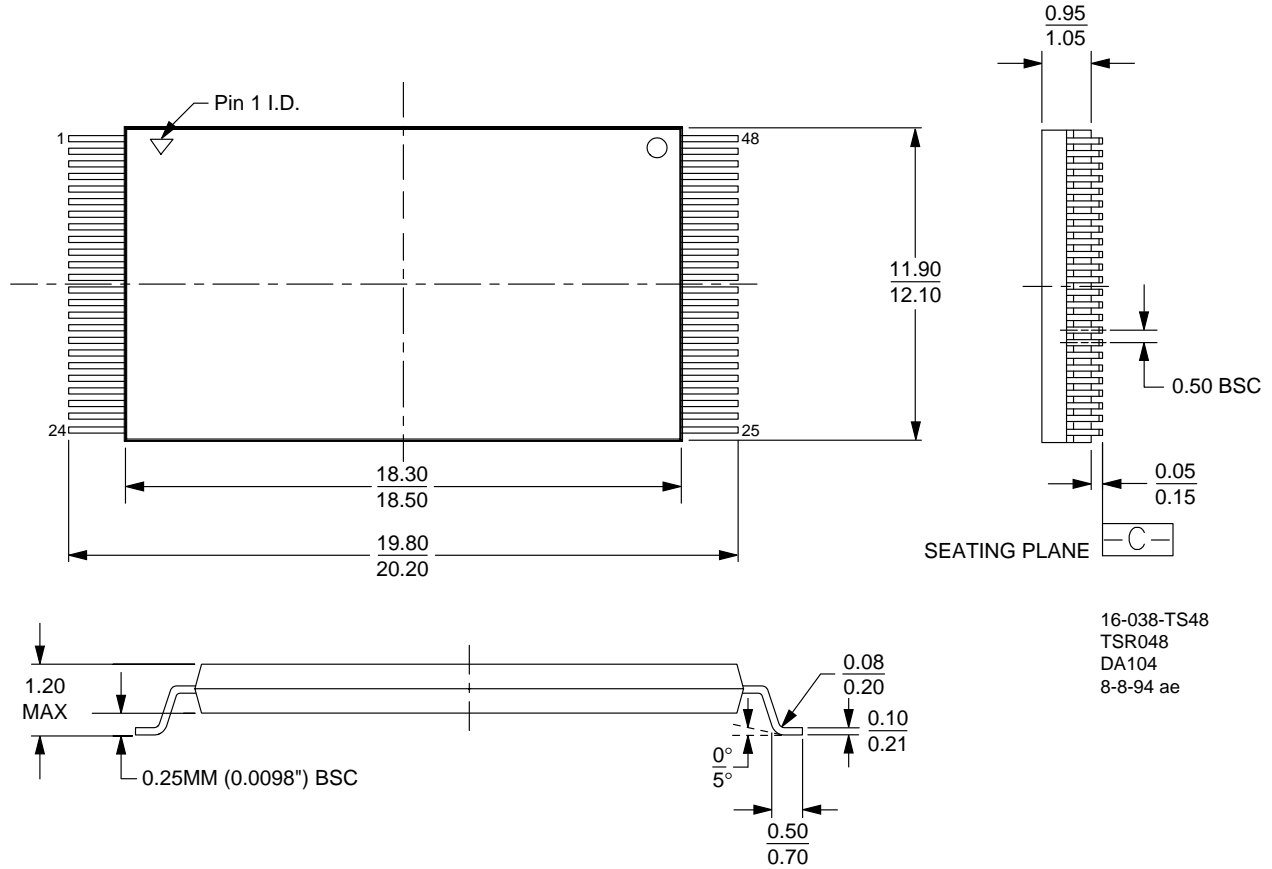

16-038-TS48
 TSR048
 DA104
 8-8-94 ae

PHYSICAL DIMENSIONS (continued)

SO 044

44-Pin Small Outline Package (measured in millimeters)

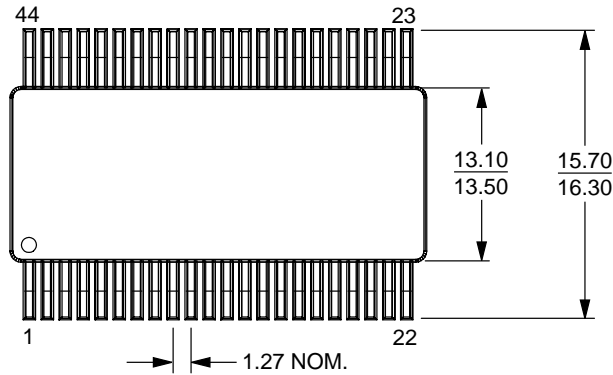

TOP VIEW

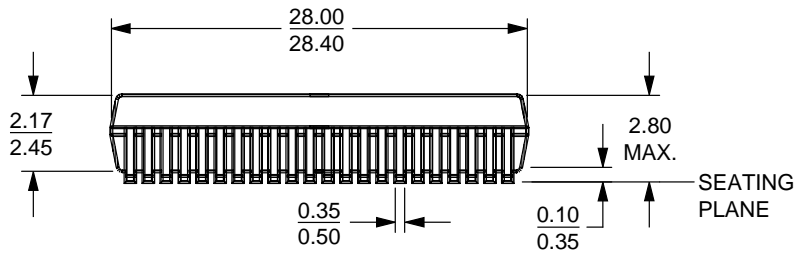

SIDE VIEW

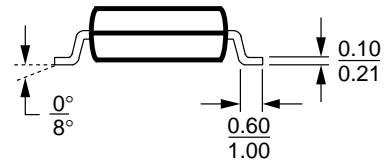

END VIEW

16-038-SO44-2
 SO 044
 DA82
 11-9-95 lv