

SPANSION™ MCP

Data Sheet



September 2003

This document specifies SPANSION™ memory products that are now offered by both Advanced Micro Devices and Fujitsu. Although the document is marked with the name of the company that originally developed the specification, these products will be offered to customers of both AMD and Fujitsu.

Continuity of Specifications

There is no change to this datasheet as a result of offering the device as a SPANSION™ product. Future routine revisions will occur when appropriate, and changes will be noted in a revision summary.

Continuity of Ordering Part Numbers

AMD and Fujitsu continue to support existing part numbers beginning with "Am" and "MBM". To order these products, please use only the Ordering Part Numbers listed in this document.

For More Information

Please contact your local AMD or Fujitsu sales office for additional information about SPANSION™ memory solutions.



Stacked MCP (Multi-Chip Package) FLASH MEMORY & FCRAM
CMOS

64M (×16) FLASH MEMORY & 16M (×16) Mobile FCRAM™

MB84VD23381HJ-70

■ FEATURES

- Power Supply Voltage of 2.7 V to 3.1 V
- High Performance
 - 70 ns maximum random access time (Flash)
 - 60 ns maximum random access time (FCRAM)
- Operating Temperature
 - 30 °C to +85 °C
- Package 56-ball BGA

(Continued)

■ PRODUCT LINEUP

	Flash	FCRAM
Supply Voltage (V)	$V_{ccf}^* = 3.0 \text{ V} \begin{matrix} +0.1 \text{ V} \\ -0.3 \text{ V} \end{matrix}$	$V_{ccr}^* = 3.0 \text{ V} \begin{matrix} +0.1 \text{ V} \\ -0.3 \text{ V} \end{matrix}$
Max Random Address Access Time (ns)	70	60
Max $\overline{\text{CE}}$ Access Time (ns)	70	60
Max $\overline{\text{OE}}$ Access Time (ns)	30	35

* : Both V_{ccf} and V_{ccr} must be the same level when either part is being accessed.

■ PACKAGE

56-ball plastic FBGA

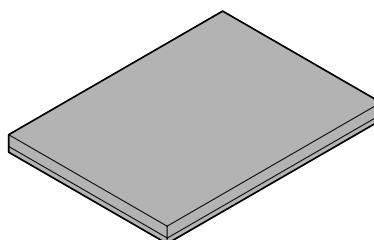

BGA-56P-M04

MBVD23381HJ-70

(Continued)

— FLASH MEMORY

- **Simultaneous Read/Write operations (Dual Bank)**
- **FlexBank™*1**
 - Bank A : 8 Mbit (8 KB × 8 and 64 KB × 15)
 - Bank B : 24 Mbit (64 KB × 48)
 - Bank C : 24 Mbit (64 KB × 48)
 - Bank D : 8 Mbit (8 KB × 8 and 64 KB × 15)Two virtual Banks are chosen from the combination of four physical banks.
Host system can program or erase in one bank, and then read immediately and simultaneously from the other bank with zero latency between read and write operations.
Read-while-erase
Read-while-program
- **Minimum 100,000 program/erase cycles**
- **Sector erase architecture**
 - Sixteen 4 Kword and one hundred twenty-six 32 Kword sectors in word.
 - Any combination of sectors can be concurrently erased. It also supports full chip erase.
- **WP/ACC input pin**
 - At V_{IL} , allows protection of “outermost” 2 × 8 Kbytes on both ends of boot sectors, regardless of sector protection/unprotection status
 - At V_{IH} , allows removal of boot sector protection
 - At V_{ACC} , increases program performance
- **Embedded Erase™*2 Algorithms**
 - Automatically preprograms and erases the chip or any sector
- **Embedded Program™*2 Algorithms**
 - Automatically writes and verifies data at specified address
- **Ready/Busy output (RY/BY)**
 - Hardware method for detection of program or erase cycle completion
- **Automatic sleep mode**
 - When addresses remain stable, the device automatically switches itself to low power mode.
- **Low V_{CC} write inhibit ≤ 2.5 V**
- **Program Suspend/Resume**
 - Suspends the program operation to allow a read in another byte
- **Erase Suspend/Resume**
 - Suspends the erase operation to allow a read data and/or program in another sector within the same device
- **Please refer to “MBM29DL64DH” Datasheet in detailed function**

(Continued)

(Continued)

— FCRAM™*3

- **Power Dissipation**

Operating : 20 mA Max

Standby : 70 μ A Max

- **Power Down Mode**

Sleep : 10 μ A Max

- **Power Down Control by CE2r**

- **Byte Write Control: $\overline{\text{LB}}$ (DQ₇ to DQ₀), $\overline{\text{UB}}$ (DQ₁₅ to DQ₈)**

- **8 words Address Access Capability**

*1: FlexBank™ is a trademark of Fujitsu Limited, Japan.

*2: Embedded Erase™ and Embedded Program™ are trademarks of Advanced Micro Devices, Inc.

*3: FCRAM™ is a trademark of Fujitsu Limited, Japan.

MBVD23381HJ-70

■ PIN ASSIGNMENT

(Top View)
Marking Side

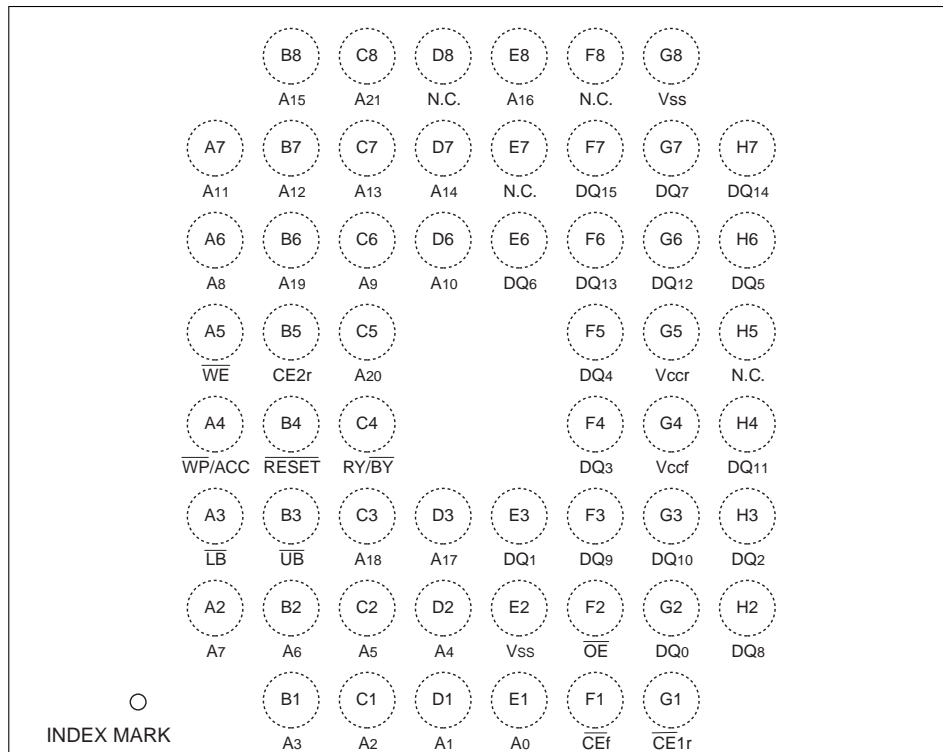

(BGA-56P-M04)

■ PIN DESCRIPTION

Pin name	Input/ Output	Description
A ₁₉ to A ₀	I	Address Inputs (Common)
A ₂₁ , A ₂₀	I	Address Inputs (Flash)
DQ ₁₅ to DQ ₀	I/O	Data Inputs/Outputs (Common)
$\overline{CE}f$	I	Chip Enable (Flash)
$\overline{CE}1r$	I	Chip Enable (FCRAM)
CE2r	I	Chip Enable (FCRAM)
\overline{OE}	I	Output Enable (Common)
\overline{WE}	I	Write Enable (Common)
RY/ \overline{BY}	O	Ready/Busy Output (Flash) Open Drain Output
\overline{UB}	I	Upper Byte Control (FCRAM)
\overline{LB}	I	Lower Byte Control (FCRAM)
\overline{RESET}	I	Hardware Reset Pin/Sector Protection Unlock (Flash)
\overline{WP}/ACC	I	Write Protect / Acceleration (Flash)
N.C.	—	No Internal Connection
V _{ss}	Power	Device Ground (Common)
V _{ccf}	Power	Device Power Supply (Flash)
V _{ccr}	Power	Device Power Supply (FCRAM)

MBVD23381HJ-70

■ BLOCK DIAGRAM

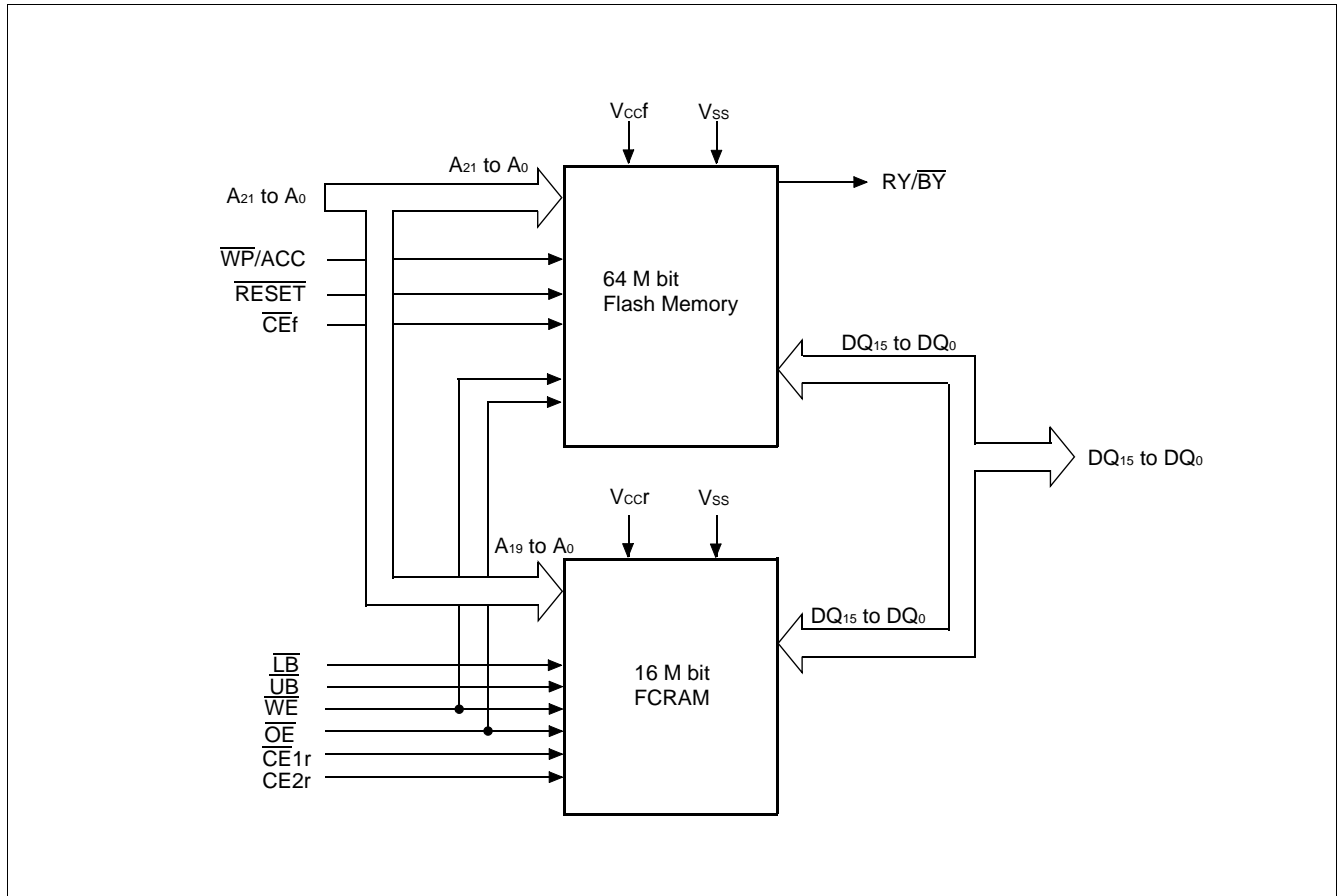

■ DEVICE BUS OPERATIONS

Operation*1, *2	\overline{CEf}	$\overline{CE1r}$	CE2r	\overline{OE}	\overline{WE}	\overline{LB}	\overline{UB}	A ₂₁ to A ₀	DQ ₇ to DQ ₀	DQ ₁₅ to DQ ₈	\overline{RESET}	$\overline{WP/ACC}$ *9
Full Standby	H	H	H	X	X	X	X	X	High-Z	High-Z	H	X
Output Disable*3	H	L	H	H	H	X	X	X*8	High-Z	High-Z	H	X
	L	H										
Read from Flash*4	L	H	H	L	H	X	X	Valid	D _{OUT}	D _{OUT}	H	X
Write to Flash	L	H	H	H	L	X	X	Valid	D _{IN}	D _{IN}	H	X
Read from FCRAM*10	H	L	H	L	H	L*7	L*7	Valid	D _{IN}	D _{IN}	H	X
FCRAM No Read	H	L	H	L	H	H	H	Valid	High-Z	High-Z	H	X
Write to FCRAM	H	L	H	H	L	L	L	Valid	D _{IN}	D _{IN}	H	X
						H	L		High-Z	D _{IN}		
						L	H		D _{IN}	High-Z		
FCRAM No Write	H	L	H	H	L	H	H	Valid	High-Z	High-Z	H	X
Flash Temporary Sector Group Unprotection*5	X	X	X	X	X	X	X	X	X	X	V _{ID}	X
Flash Hardware Reset	X	H	H	X	X	X	X	X	High-Z	High-Z	L	X
Flash Boot Block Sector Write Protection	X	X	X	X	X	X	X	X	X	X	X	L
FCRAM Power Down*6	X	X	L	X	X	X	X	X	High-Z	High-Z	X	X

Legend : L = V_{IL}, H = V_{IH}, X can be either V_{IL} or V_{IH}, High-Z = High Impedance.

See DC Characteristics for voltage levels.

*1 : Other operations except for indicated this column are inhibited.

*2 : Do not apply for a following state two or more on the same time;

1) $\overline{CEf} = V_{IL}$

2) $\overline{CE1r} = V_{IL}$ and CE2r = V_{IH}

*3 : FCRAM Output Disable mode should not be kept longer than 1 μs.

*4 : \overline{WE} can be V_{IL} if \overline{OE} is V_{IL}, \overline{OE} at V_{IH} initiates the write operations.

*5 : It is also used for the extended sector group protections.

*6 : FCRAM Power Down mode can be entered from Standby state and all DQ pins are in High-Z state.

*7 : Either or both \overline{LB} and \overline{UB} must be Low for Read operation.

*8 : Can be either V_{IL} or V_{IH} but must be valid before FCRAM Read or Write.

*9 : Protect “outer most” 2 × 8K bytes (4 words) on both ends of the boot block sectors.

*10 : FCRAM Byte control at Read mode is not supported.

MBVD23381HJ-70

■ ABSOLUTE MAXIMUM RATINGS

Parameter	Symbol	Rating		Unit
		Min	Max	
Storage Temperature	T _{stg}	-55	+125	°C
Ambient Temperature with Power Applied	T _A	-30	+85	°C
Voltage with Respect to Ground All pins except $\overline{\text{RESET}}$, $\overline{\text{WP/ACC}}$ *1	V _{IN} , V _{OUT}	-0.3	V _{ccf} + 0.3	V
			V _{ccr} + 0.3	V
V _{ccf} /V _{ccr} Supply *1	V _{ccf} , V _{ccr}	-0.3	+3.3	V
$\overline{\text{RESET}}$ *2	V _{IN}	-0.5	+13.0	V
$\overline{\text{WP/ACC}}$ *3	V _{IN}	-0.5	+10.5	V

*1: Minimum DC voltage on input or I/O pins is -0.3 V. During voltage transitions, input or I/O pins may undershoot V_{SS} to -1.0 V for periods of up to 5 ns. Maximum DC voltage on input or I/O pins is V_{ccf} + 0.3 V or V_{ccr} + 0.3 V. During voltage transitions, input or I/O pins may overshoot to V_{ccf} + 2.0 V or V_{ccr} + 1.0 V for periods of up to 5 ns.

*2: Minimum DC input voltage on $\overline{\text{RESET}}$ pin is -0.5 V. During voltage transitions $\overline{\text{RESET}}$ pins may undershoot V_{SS} to -2.0 V for periods of up to 20 ns. Voltage difference between input and supply voltage (V_{IN}-V_{ccf}) does not exceed +9.0 V. Maximum DC input voltage on $\overline{\text{RESET}}$ pins is +13.0 V which may overshoot to +14.0 V for periods of up to 20 ns.

*3: Minimum DC input voltage on $\overline{\text{WP/ACC}}$ pin is -0.5 V. During voltage transitions, $\overline{\text{WP/ACC}}$ pin may undershoot V_{SS} to -2.0 V for periods of up to 20 ns. Maximum DC input voltage on $\overline{\text{WP/ACC}}$ pin is +10.5 V which may overshoot to +12.0 V for periods of up to 20 ns, when V_{ccf} is applied.

WARNING: Semiconductor devices can be permanently damaged by application of stress (voltage, current, temperature, etc.) in excess of absolute maximum ratings. Do not exceed these ratings.

■ RECOMMENDED OPERATING CONDITIONS

Parameter	Symbol	Value		Unit
		Min	Max	
Ambient Temperature	T _A	-30	+85	°C
V _{ccf} /V _{ccr} Supply Voltages	V _{ccf} , V _{ccr}	+2.7	+3.1	V

WARNING: The recommended operating conditions are required in order to ensure the normal operation of the semiconductor device. All of the device's electrical characteristics are warranted when the device is operated within these ranges.

Always use semiconductor devices within their recommended operating condition ranges. Operation outside these ranges may adversely affect reliability and could result in device failure.

No warranty is made with respect to uses, operating conditions, or combinations not represented on the data sheet. Users considering application outside the listed conditions are advised to contact their FUJITSU representatives beforehand.

Note: Operating ranges define those limits between which the functionality of the device is guaranteed.

■ ELECTRICAL CHARACTERISTICS (DC Characteristics)

Parameter	Symbol	Conditions	Value			Unit
			Min	Typ	Max	
Input Leakage Current	I_{LI}	$V_{IN} = V_{SS} \text{ to } V_{CCf}, V_{CCr}$	-1.0	—	+1.0	μA
Output Leakage Current	I_{LO}	$V_{OUT} = V_{SS} \text{ to } V_{CCf}, V_{CCr}, \text{ Output Disable}$	-1.0	—	+1.0	μA
$\overline{\text{RESET}}$ Inputs Leakage Current	I_{LIT}	$V_{CCf} = V_{CCf} \text{ Max}, \overline{\text{RESET}} = 12.5 \text{ V}$	—	—	35	μA
Flash V_{CC} Active Current (Read) *1	I_{CC1f}	$\overline{\text{CE}}f = V_{IL}, t_{\text{CYCLE}} = 5 \text{ MHz}$	—	—	18	mA
		$\overline{\text{OE}} = V_{IH}, t_{\text{CYCLE}} = 1 \text{ MHz}$	—	—	4	mA
Flash V_{CC} Active Current (Program/Erase) *2	I_{CC2f}	$\overline{\text{CE}}f = V_{IL}, \overline{\text{OE}} = V_{IH}$	—	—	35	mA
Flash V_{CC} Active Current (Read-While-Program) *5	I_{CC3f}	$\overline{\text{CE}}f = V_{IL}, \overline{\text{OE}} = V_{IH}$	—	—	53	mA
Flash V_{CC} Active Current (Read-While-Erase) *5	I_{CC4f}	$\overline{\text{CE}}f = V_{IL}, \overline{\text{OE}} = V_{IH}$	—	—	53	mA
Flash V_{CC} Active Current (Erase-Suspend-Program)	I_{CC5f}	$\overline{\text{CE}}f = V_{IL}, \overline{\text{OE}} = V_{IH}$	—	—	40	mA
$\overline{\text{WP/ACC}}$ Acceleration Program Current	I_{ACC}	$V_{CCf} = V_{CCf} \text{ Max}, \overline{\text{WP/ACC}} = V_{ACC} \text{ Max}$	—	—	20	mA
Flash V_{CC} Current (Standby)	I_{SB1f}	$V_{CCf} = V_{CCf} \text{ Max}, \overline{\text{CE}}f = V_{CCf} \pm 0.3 \text{ V}, \overline{\text{RESET}} = V_{CCf} \pm 0.3 \text{ V}, \overline{\text{WP/ACC}} = V_{CCf} \pm 0.3 \text{ V}$	—	1	5	μA
Flash V_{CC} Current (Standby,Reset)	I_{SB2f}	$V_{CCf} = V_{CCf} \text{ Max}, \overline{\text{RESET}} = V_{SS} \pm 0.3 \text{ V}$	—	1	5	μA
Flash V_{CC} Current (Automatic Sleep Mode)*3	I_{SB3f}	$V_{CCf} = V_{CCf} \text{ Max}, \overline{\text{CE}}f = V_{SS} \pm 0.3 \text{ V}, \overline{\text{RESET}} = V_{CCf} \pm 0.3 \text{ V}, V_{IN} = V_{CCf} \pm 0.3 \text{ V} \text{ or } V_{SSf} \pm 0.3 \text{ V}$	—	1	5	μA
FCRAM V_{CC} Active Current*8	I_{CC1r}	$V_{CCr} = V_{CCr} \text{ Max}, t_{RC} / t_{WC} = \text{Min}$	—	—	20	mA
	I_{CC2r}	$\overline{\text{CE}}1r = V_{IL}, \text{CE}2r = V_{IH}, V_{IN} = V_{CCr} - 0.5 \text{ V} \text{ or } V_{IL}, I_{OUT} = 0 \text{ mA}^{*7}$, $t_{RC} / t_{WC} = 1 \mu\text{s}$	—	—	3	
FCRAM V_{CC} Standby Current*8	I_{SB1r}	$V_{CCr} = V_{CCr} \text{ Max}, V_{IN} \leq 0.2 \text{ V} \text{ or } V_{IN} \geq V_{CCr} - 0.2 \text{ V}, \overline{\text{CE}}1r \geq V_{CCr} - 0.2 \text{ V}, \text{CE}2r \geq V_{CCr} - 0.2 \text{ V}$	—	—	70	μA
FCRAM V_{CC} Power Down Current	I_{DDPSr}	$V_{CCr} = V_{CCr} \text{ Max}, \text{CE}2r \leq 0.2 \text{ V}, V_{IN} = V_{IH} \text{ or } V_{IL}$	—	—	10	μA
Input Low Level	V_{IL}	—	-0.3	—	0.5	V
Input High Level	V_{IH}	—	2.2	—	$V_{CC+} 0.2^{*6}$	V

(Continued)

MBVD23381HJ-70

(Continued)

Parameter	Symbol	Conditions		Value			Unit
				Min	Typ	Max	
Voltage for Sector Protection, and Temporary Sector Unprotection (RESET) *4	V _{ID}	—		11.5	12	12.5	V
Voltage for \overline{WP}/ACC Sector Protection/Unprotection and Program Acceleration *4	V _{ACC}	—		8.5	9.0	9.5	V
Output Low Voltage Level	V _{OLf}	V _{CCf} = V _{CCf} Min, I _{OL} = 4.0 mA	Flash	—	—	0.45	V
	V _{OLr}	V _{CCr} = V _{CCr} Min, I _{OL} = 1.0 mA	FCRAM	—	—	0.4	V
Output High Voltage Level	V _{OHf}	V _{CCf} = V _{CCf} Min, I _{OH} = -2.0 mA	Flash	2.4	—	—	V
	V _{OHr}	V _{CCr} = V _{CCr} Min, I _{OH} = -0.5mA	FCRAM	2.2	—	—	V
Flash Low V _{CCf} Lock-Out Voltage	V _{LKO}	—		2.3	2.4	2.5	V

*1 : The I_{CC} current listed includes both the DC operating current and the frequency dependent component.

*2 : I_{CC} active while Embedded Algorithm (program or erase) is in progress.

*3 : Automatic sleep mode enables the low power mode when address remains stable for 150 ns.

*4 : Applicable for only V_{CCf} applying.

*5 : Embedded Alogrithm (program or erase) is in progress (@5 MHz).

*6 : V_{CC} indicates lower of V_{CCf} or V_{CCr}.

*7 : FCRAM Characteristics are mesured after following POWER-UP timing.

*8 : I_{OUT} depends on the output load conditions.

■ ELECTRICAL CHARACTERISTICS (AC Characteristics)

• \overline{CE} Timing

Parameter	Symbol		Condition	Value		Unit
	JEDEC	Standard		Min	Max	
\overline{CE} Recover Time	—	t_{CCR}	—	0	—	ns
\overline{CE} Hold Time	—	t_{CHOLD}	—	3	—	ns
$\overline{CE1r}$ High to \overline{WE} Invalid time for Standby Entry	—	t_{CHWX}	—	10	—	ns

• Timing Diagram for alternating RAM to Flash

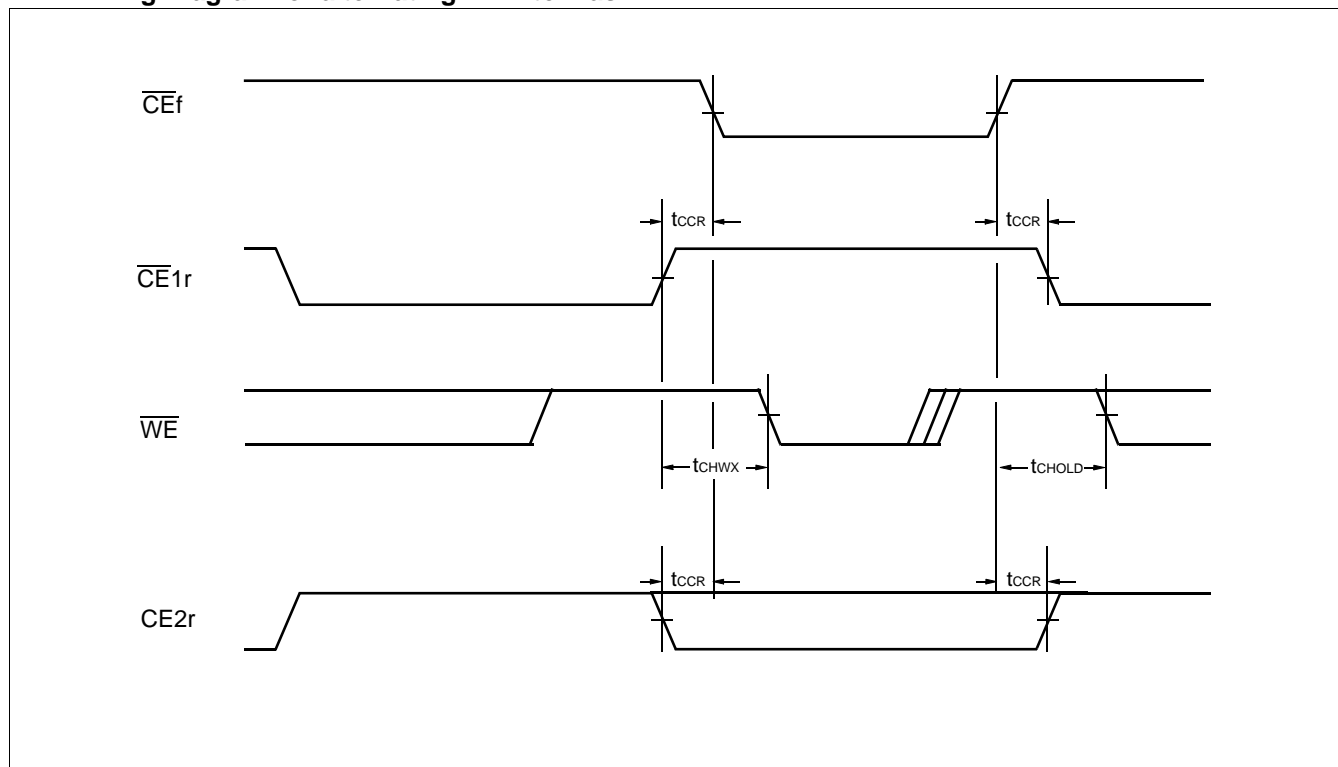

• Flash Characteristics

Please refer to “■ 64M FLASH MEMORY CHARACTERISTICS FOR MCP”.

• FCRAM Characteristics

Please refer to “■ 16M FCRAM CHARACTERISTICS FOR MCP”.

MBVD23381HJ-70

64M FLASH MEMORY CHARACTERISTICS FOR MCP

1. Flexible Sector-erase Architecture on Flash Memory

- Sixteen 4K words, and one hundred twenty-six 32 K words.
- Individual-sector, multiple-sector, or bulk-erase capability.

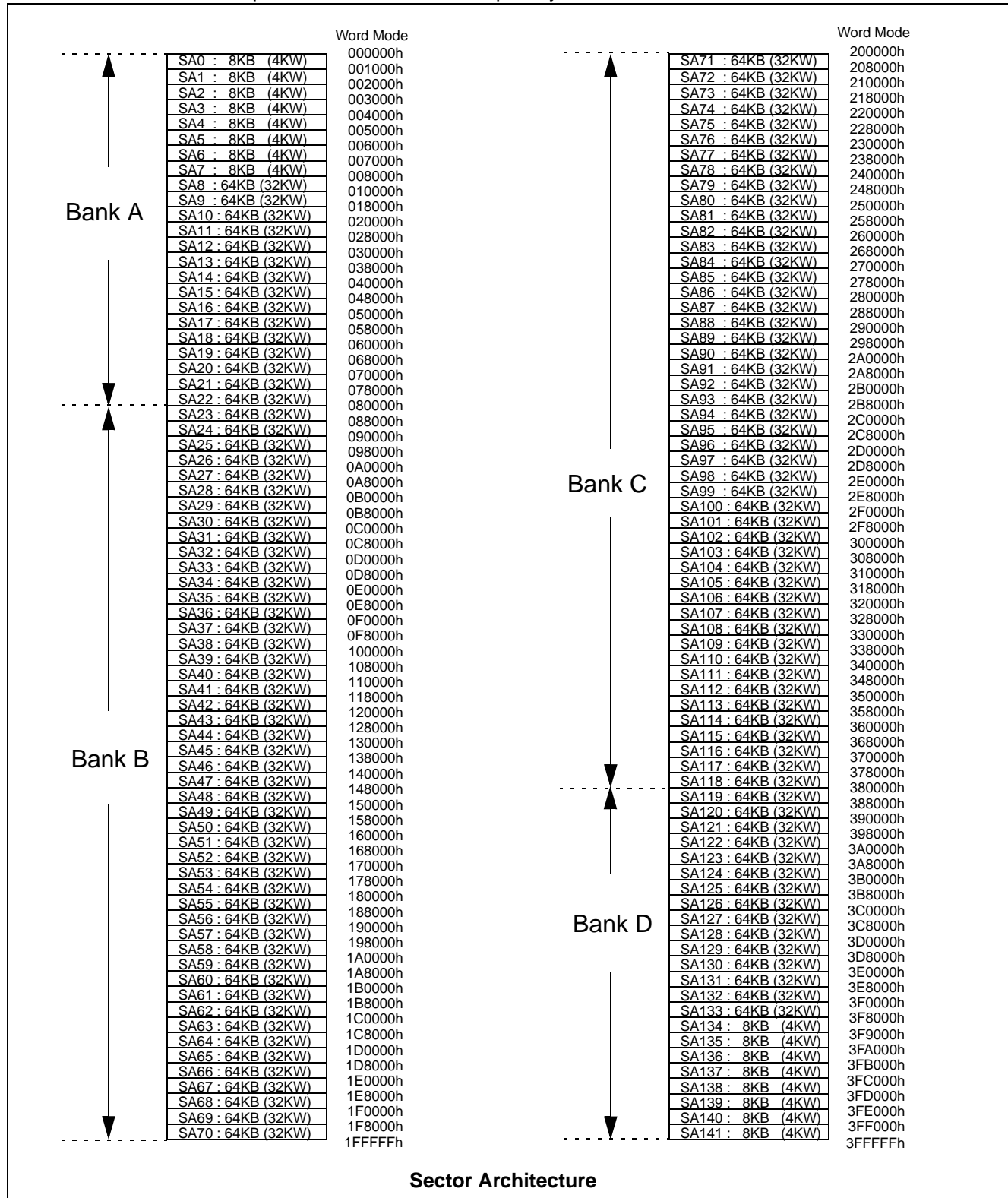

FlexBank™ Architecture

Bank Splits	Bank 1		Bank 2	
	Volume	Combination	Volume	Combination
1	8 Mbit	Bank A	56 Mbit	Remainder (Bank B, C, D)
2	24 Mbit	Bank B	40 Mbit	Remainder (Bank A, C, D)
3	24 Mbit	Bank C	40 Mbit	Remainder (Bank A, B, D)
4	8 Mbit	Bank D	56 Mbit	Remainder (Bank A, B, C)

Example of Virtual Banks Combination

Bank Splits	Bank 1			Bank 2		
	Volume	Combination	Sector Size	Volume	Combination	Sector Size
1	8 Mbit	Bank A	8 × 8 Kbyte/4 Kword + 15 × 64 Kbyte/32 Kword	56 Mbit	Bank B + Bank C + Bank D	8 × 8 Kbyte/4 Kword + 111 × 64 Kbyte/32 Kword
2	16 Mbit	Bank A + Bank D	16 × 8 Kbyte/4 Kword + 30 × 64 Kbyte/32 Kword	48 Mbit	Bank B + Bank C	96 × 64 Kbyte/32 Kword
3	24 Mbit	Bank B	48 × 64 Kbyte/32 Kword	40 Mbit	Bank A + Bank C + Bank D	16 × 8 Kbyte/4 Kword + 78 × 64 Kbyte/32 Kword
4	32 Mbit	Bank A + Bank B	8 × 8 Kbyte/4 Kword + 63 × 64 Kbyte/32 Kword	32 Mbit	Bank C + Bank D	8 × 8 Kbyte/4 Kword + 63 × 64 Kbyte/32 Kword

Note : When multiple sector erase over several banks is operated, the system cannot read out of the bank to which a sector being erased belongs. For example, suppose that erasing is taking place at both Bank A and Bank B, neither Bank A nor Bank B is read out (they would output the sequence flag once they were selected.) Meanwhile the system would get to read from either Bank C or Bank D.

Simultaneous Operation

Case	Bank 1 Status	Bank 2 Status
1	Read mode	Read mode
2	Read mode	Autoselect mode
3	Read mode	Program mode
4	Read mode	Erase mode*
5	Autoselect mode	Read mode
6	Program mode	Read mode
7	Erase mode*	Read mode

* : By writing erase suspend command on the bank address of sector being erased, the erase operation gets suspended so that it enables reading from or programming the remaining sectors.

Note: Bank 1 and Bank 2 are divided for the sake of convenience at Simultaneous Operation. Actually, the Bank consists of 4 banks, Bank A, Bank B, BankC and Bank D. Bank Address (BA) meant to specify each of the Banks.

MBVD23381HJ-70

Sector Address Tables

Bank	Sector	Sector Address										Address Range
		Bank Address			A ₁₈	A ₁₇	A ₁₆	A ₁₅	A ₁₄	A ₁₃	A ₁₂	Word Mode
		A ₂₁	A ₂₀	A ₁₉								
Bank A	SA0	0	0	0	0	0	0	0	0	0	0	00000h to 000FFFh
	SA1	0	0	0	0	0	0	0	0	0	1	001000h to 001FFFh
	SA2	0	0	0	0	0	0	0	0	1	0	002000h to 002FFFh
	SA3	0	0	0	0	0	0	0	0	1	1	003000h to 003FFFh
	SA4	0	0	0	0	0	0	0	1	0	0	004000h to 004FFFh
	SA5	0	0	0	0	0	0	0	1	0	1	005000h to 005FFFh
	SA6	0	0	0	0	0	0	0	1	1	0	006000h to 006FFFh
	SA7	0	0	0	0	0	0	0	1	1	1	007000h to 007FFFh
	SA8	0	0	0	0	0	0	1	X	X	X	008000h to 00FFFFh
	SA9	0	0	0	0	0	1	0	X	X	X	010000h to 017FFFh
	SA10	0	0	0	0	0	1	1	X	X	X	018000h to 01FFFFh
	SA11	0	0	0	0	1	0	0	X	X	X	020000h to 027FFFh
	SA12	0	0	0	0	1	0	1	X	X	X	028000h to 02FFFFh
	SA13	0	0	0	0	1	1	0	X	X	X	030000h to 037FFFh
	SA14	0	0	0	0	1	1	1	X	X	X	038000h to 03FFFFh
	SA15	0	0	0	1	0	0	0	X	X	X	040000h to 047FFFh
	SA16	0	0	0	1	0	0	1	X	X	X	048000h to 04FFFFh
	SA17	0	0	0	1	0	1	0	X	X	X	050000h to 057FFFh
	SA18	0	0	0	1	0	1	1	X	X	X	058000h to 05FFFFh
	SA19	0	0	0	1	1	0	0	X	X	X	060000h to 067FFFh
	SA20	0	0	0	1	1	0	1	X	X	X	068000h to 06FFFFh
	SA21	0	0	0	1	1	1	0	X	X	X	070000h to 077FFFh
SA22	0	0	0	1	1	1	1	X	X	X	078000h to 07FFFFh	

(Continued)

MB84VD23381HJ-70

Bank	Sector	Sector Address										Address Range
		Bank Address			A ₁₈	A ₁₇	A ₁₆	A ₁₅	A ₁₄	A ₁₃	A ₁₂	Word Mode
		A ₂₁	A ₂₀	A ₁₉								
Bank B	SA23	0	0	1	0	0	0	0	X	X	X	080000h to 087FFFh
	SA24	0	0	1	0	0	0	1	X	X	X	088000h to 08FFFFh
	SA25	0	0	1	0	0	1	0	X	X	X	090000h to 097FFFh
	SA26	0	0	1	0	0	1	1	X	X	X	098000h to 09FFFFh
	SA27	0	0	1	0	1	0	0	X	X	X	0A0000h to 0A7FFFh
	SA28	0	0	1	0	1	0	1	X	X	X	0A8000h to 0AFFFFh
	SA29	0	0	1	0	1	1	0	X	X	X	0B0000h to 0B7FFFh
	SA30	0	0	1	0	1	1	1	X	X	X	0B8000h to 0BFFFFh
	SA31	0	0	1	1	0	0	0	X	X	X	0C0000h to 0C7FFFh
	SA32	0	0	1	1	0	0	1	X	X	X	0C8000h to 0CFFFFh
	SA33	0	0	1	1	0	1	0	X	X	X	0D0000h to 0D7FFFh
	SA34	0	0	1	1	0	1	1	X	X	X	0D8000h to 0DFFFFh
	SA35	0	0	1	1	1	0	0	X	X	X	0E0000h to 0E7FFFh
	SA36	0	0	1	1	1	0	1	X	X	X	0E8000h to 0EFFFFh
	SA37	0	0	1	1	1	1	0	X	X	X	0F0000h to 0F7FFFh
	SA38	0	0	1	1	1	1	1	X	X	X	0F8000h to 0FFFFh
	SA39	0	1	0	0	0	0	0	X	X	X	100000h to 107FFFh
	SA40	0	1	0	0	0	0	1	X	X	X	108000h to 10FFFFh
	SA41	0	1	0	0	0	1	0	X	X	X	110000h to 117FFFh
	SA42	0	1	0	0	0	1	1	X	X	X	118000h to 11FFFFh
	SA43	0	1	0	0	1	0	0	X	X	X	120000h to 127FFFh
	SA44	0	1	0	0	1	0	1	X	X	X	128000h to 12FFFFh
	SA45	0	1	0	0	1	1	0	X	X	X	130000h to 137FFFh
	SA46	0	1	0	0	1	1	1	X	X	X	138000h to 13FFFFh
	SA47	0	1	0	1	0	0	0	X	X	X	140000h to 147FFFh
	SA48	0	1	0	1	0	0	1	X	X	X	148000h to 14FFFFh
	SA49	0	1	0	1	0	1	0	X	X	X	150000h to 157FFFh
	SA50	0	1	0	1	0	1	1	X	X	X	158000h to 15FFFFh
	SA51	0	1	0	1	1	0	0	X	X	X	160000h to 167FFFh
	SA52	0	1	0	1	1	0	1	X	X	X	168000h to 16FFFFh
	SA53	0	1	0	1	1	1	0	X	X	X	170000h to 177FFFh
	SA54	0	1	0	1	1	1	1	X	X	X	178000h to 17FFFFh
SA55	0	1	1	0	0	0	0	X	X	X	180000h to 187FFFh	
SA56	0	1	1	0	0	0	1	X	X	X	188000h to 18FFFFh	
SA57	0	1	1	0	0	1	0	X	X	X	190000h to 197FFFh	
SA58	0	1	1	0	0	1	1	X	X	X	198000h to 19FFFFh	
SA59	0	1	1	0	1	0	0	X	X	X	1A0000h to 1A7FFFh	
SA60	0	1	1	0	1	0	1	X	X	X	1A8000h to 1AFFFFh	
SA61	0	1	1	0	1	1	0	X	X	X	1B0000h to 1B7FFFh	
SA62	0	1	1	0	1	1	1	X	X	X	1B8000h to 1BFFFFh	
SA63	0	1	1	1	0	0	0	X	X	X	1C0000h to 1C7FFFh	
SA64	0	1	1	1	0	0	1	X	X	X	1C8000h to 1CFFFFh	
SA65	0	1	1	1	0	1	0	X	X	X	1D0000h to 1D7FFFh	
SA66	0	1	1	1	0	1	1	X	X	X	1D8000h to 1DFFFFh	
SA67	0	1	1	1	1	0	0	X	X	X	1E0000h to 1E7FFFh	
SA68	0	1	1	1	1	0	1	X	X	X	1E8000h to 1EFFFFh	
SA69	0	1	1	1	1	1	0	X	X	X	1F0000h to 1F7FFFh	
SA70	0	1	1	1	1	1	1	X	X	X	1F8000h to 1FFFFh	

(Continued)

MBVD23381HJ-70

Bank	Sector	Sector Address										Address Range
		Bank Address			A ₁₈	A ₁₇	A ₁₆	A ₁₅	A ₁₄	A ₁₃	A ₁₂	Word Mode
		A ₂₁	A ₂₀	A ₁₉								
Bank C	SA71	1	0	0	0	0	0	0	X	X	X	20000h to 207FFFh
	SA72	1	0	0	0	0	0	1	X	X	X	208000h to 20FFFFh
	SA73	1	0	0	0	0	1	0	X	X	X	210000h to 217FFFh
	SA74	1	0	0	0	0	1	1	X	X	X	218000h to 21FFFFh
	SA75	1	0	0	0	1	0	0	X	X	X	220000h to 227FFFh
	SA76	1	0	0	0	1	0	1	X	X	X	228000h to 22FFFFh
	SA77	1	0	0	0	1	1	0	X	X	X	230000h to 237FFFh
	SA78	1	0	0	0	1	1	1	X	X	X	238000h to 23FFFFh
	SA79	1	0	0	1	0	0	0	X	X	X	240000h to 247FFFh
	SA80	1	0	0	1	0	0	1	X	X	X	248000h to 24FFFFh
	SA81	1	0	0	1	0	1	0	X	X	X	250000h to 257FFFh
	SA82	1	0	0	1	0	1	1	X	X	X	258000h to 25FFFFh
	SA83	1	0	0	1	1	0	0	X	X	X	260000h to 267FFFh
	SA84	1	0	0	1	1	0	1	X	X	X	268000h to 26FFFFh
	SA85	1	0	0	1	1	1	0	X	X	X	270000h to 277FFFh
	SA86	1	0	0	1	1	1	1	X	X	X	278000h to 27FFFFh
	SA87	1	0	1	0	0	0	0	X	X	X	280000h to 287FFFh
	SA88	1	0	1	0	0	0	1	X	X	X	288000h to 28FFFFh
	SA89	1	0	1	0	0	1	0	X	X	X	290000h to 297FFFh
	SA90	1	0	1	0	0	1	1	X	X	X	298000h to 29FFFFh
	SA91	1	0	1	0	1	0	0	X	X	X	2A0000h to 2A7FFFh
	SA92	1	0	1	0	1	0	1	X	X	X	2A8000h to 2AFFFFh
	SA93	1	0	1	0	1	1	0	X	X	X	2B0000h to 2B7FFFh
	SA94	1	0	1	0	1	1	1	X	X	X	2B8000h to 2BFFFFh
	SA95	1	0	1	1	0	0	0	X	X	X	2C0000h to 2C7FFFh
	SA96	1	0	1	1	0	0	1	X	X	X	2C8000h to 2CFFFFh
	SA97	1	0	1	1	0	1	0	X	X	X	2D0000h to 2D7FFFh
	SA98	1	0	1	1	0	1	1	X	X	X	2D8000h to 2DFFFFh
	SA99	1	0	1	1	1	0	0	X	X	X	2E0000h to 2E7FFFh
	SA100	1	0	1	1	1	0	1	X	X	X	2E8000h to 2EFFFFh
SA101	1	0	1	1	1	1	0	X	X	X	2F0000h to 2F7FFFh	
SA102	1	0	1	1	1	1	1	X	X	X	2F8000h to 2FFFFh	
SA103	1	1	0	0	0	0	0	X	X	X	300000h to 307FFFh	
SA104	1	1	0	0	0	0	1	X	X	X	308000h to 30FFFFh	
SA105	1	1	0	0	0	1	0	X	X	X	310000h to 317FFFh	
SA106	1	1	0	0	0	1	1	X	X	X	318000h to 31FFFFh	
SA107	1	1	0	0	1	0	0	X	X	X	320000h to 327FFFh	
SA108	1	1	0	0	1	0	1	X	X	X	328000h to 32FFFFh	
SA109	1	1	0	0	1	1	0	X	X	X	330000h to 337FFFh	
SA110	1	1	0	0	1	1	1	X	X	X	338000h to 33FFFFh	
SA111	1	1	0	1	0	0	0	X	X	X	340000h to 347FFFh	
SA112	1	1	0	1	0	0	1	X	X	X	348000h to 34FFFFh	
SA113	1	1	0	1	0	1	0	X	X	X	350000h to 357FFFh	
SA114	1	1	0	1	0	1	1	X	X	X	358000h to 35FFFFh	
SA115	1	1	0	1	1	0	0	X	X	X	360000h to 367FFFh	
SA116	1	1	0	1	1	0	1	X	X	X	368000h to 36FFFFh	
SA117	1	1	0	1	1	1	0	X	X	X	370000h to 377FFFh	
SA118	1	1	0	1	1	1	1	X	X	X	378000h to 37FFFFh	

(Continued)

(Continued)

Bank	Sector	Sector Address										Address Range
		Bank Address			A ₁₈	A ₁₇	A ₁₆	A ₁₅	A ₁₄	A ₁₃	A ₁₂	Word Mode
		A ₂₁	A ₂₀	A ₁₉								
Bank D	SA119	1	1	1	0	0	0	0	X	X	X	380000h to 387FFFh
	SA120	1	1	1	0	0	0	1	X	X	X	388000h to 38FFFFh
	SA121	1	1	1	0	0	1	0	X	X	X	390000h to 397FFFh
	SA122	1	1	1	0	0	1	1	X	X	X	398000h to 39FFFFh
	SA123	1	1	1	0	1	0	0	X	X	X	3A0000h to 3A7FFFh
	SA124	1	1	1	0	1	0	1	X	X	X	3A8000h to 3AFFFFh
	SA125	1	1	1	0	1	1	0	X	X	X	3B0000h to 3B7FFFh
	SA126	1	1	1	0	1	1	1	X	X	X	3B8000h to 3BFFFFh
	SA127	1	1	1	1	0	0	0	X	X	X	3C0000h to 3C7FFFh
	SA128	1	1	1	1	0	0	1	X	X	X	3C8000h to 3CFFFFh
	SA129	1	1	1	1	0	1	0	X	X	X	3D0000h to 3D7FFFh
	SA130	1	1	1	1	0	1	1	X	X	X	3D8000h to 3DFFFFh
	SA131	1	1	1	1	1	0	0	X	X	X	3E0000h to 3E7FFFh
	SA132	1	1	1	1	1	0	1	X	X	X	3E8000h to 3EFFFFh
	SA133	1	1	1	1	1	1	0	X	X	X	3F0000h to 3F7FFFh
	SA134	1	1	1	1	1	1	1	0	0	0	3F8000h to 3F8FFFh
	SA135	1	1	1	1	1	1	1	0	0	1	3F9000h to 3F9FFFh
	SA136	1	1	1	1	1	1	1	0	1	0	3FA000h to 3FAFFFh
SA137	1	1	1	1	1	1	1	0	1	1	3FB000h to 3FBFFFh	
SA138	1	1	1	1	1	1	1	1	0	0	3FC000h to 3FCFFFh	
SA139	1	1	1	1	1	1	1	1	0	1	3FD000h to 3FDFFFh	
SA140	1	1	1	1	1	1	1	1	1	0	3FE000h to 3FEFFFh	
SA141	1	1	1	1	1	1	1	1	1	1	3FF000h to 3FFFFFFh	

MBVD23381HJ-70

Sector Group Addresses

Sector Group	A ₂₁	A ₂₀	A ₁₉	A ₁₈	A ₁₇	A ₁₆	A ₁₅	A ₁₄	A ₁₃	A ₁₂	Sectors
SGA0	0	0	0	0	0	0	0	0	0	0	SA0
SGA1	0	0	0	0	0	0	0	0	0	1	SA1
SGA2	0	0	0	0	0	0	0	0	1	0	SA2
SGA3	0	0	0	0	0	0	0	0	1	1	SA3
SGA4	0	0	0	0	0	0	0	1	0	0	SA4
SGA5	0	0	0	0	0	0	0	1	0	1	SA5
SGA6	0	0	0	0	0	0	0	1	1	0	SA6
SGA7	0	0	0	0	0	0	0	1	1	1	SA7
SGA8	0	0	0	0	0	0	1	X	X	X	SA8 to SA10
						1	0				
						1	1				
SGA9	0	0	0	0	1	X	X	X	X	X	SA11 to SA14
SGA10	0	0	0	1	0	X	X	X	X	X	SA15 to SA18
SGA11	0	0	0	1	1	X	X	X	X	X	SA19 to SA22
SGA12	0	0	1	0	0	X	X	X	X	X	SA23 to SA26
SGA13	0	0	1	0	1	X	X	X	X	X	SA27 to SA30
SGA14	0	0	1	1	0	X	X	X	X	X	SA31 to SA34
SGA15	0	0	1	1	1	X	X	X	X	X	SA35 to SA38
SGA16	0	1	0	0	0	X	X	X	X	X	SA39 to SA42
SGA17	0	1	0	0	1	X	X	X	X	X	SA43 to SA46
SGA18	0	1	0	1	0	X	X	X	X	X	SA47 to SA50
SGA19	0	1	0	1	1	X	X	X	X	X	SA51 to SA54
SGA20	0	1	1	0	0	X	X	X	X	X	SA55 to SA58
SGA21	0	1	1	0	1	X	X	X	X	X	SA59 to SA62
SGA22	0	1	1	1	0	X	X	X	X	X	SA63 to SA66
SGA23	0	1	1	1	1	X	X	X	X	X	SA67 to SA70
SGA24	1	0	0	0	0	X	X	X	X	X	SA71 to SA74
SGA25	1	0	0	0	1	X	X	X	X	X	SA75 to SA78
SGA26	1	0	0	1	0	X	X	X	X	X	SA79 to SA82
SGA27	1	0	0	1	1	X	X	X	X	X	SA83 to SA86
SGA28	1	0	1	0	0	X	X	X	X	X	SA87 to SA90
SGA29	1	0	1	0	1	X	X	X	X	X	SA91 to SA94
SGA30	1	0	1	1	0	X	X	X	X	X	SA95 to SA98
SGA31	1	0	1	1	1	X	X	X	X	X	SA99 to SA102
SGA32	1	1	0	0	0	X	X	X	X	X	SA103 to SA106
SGA33	1	1	0	0	1	X	X	X	X	X	SA107 to SA110
SGA34	1	1	0	1	0	X	X	X	X	X	SA111 to SA114
SGA35	1	1	0	1	1	X	X	X	X	X	SA115 to SA118
SGA36	1	1	1	0	0	X	X	X	X	X	SA119 to SA122
SGA37	1	1	1	0	1	X	X	X	X	X	SA123 to SA126
SGA38	1	1	1	1	0	X	X	X	X	X	SA127 to SA130
SGA39	1	1	1	1	1	0	0	X	X	X	SA131 to SA133
						0	1				
						1	0				
SGA40	1	1	1	1	1	1	1	0	0	0	SA134
SGA41	1	1	1	1	1	1	1	0	0	1	SA135
SGA42	1	1	1	1	1	1	1	0	1	0	SA136
SGA43	1	1	1	1	1	1	1	0	1	1	SA137
SGA44	1	1	1	1	1	1	1	1	0	0	SA138
SGA45	1	1	1	1	1	1	1	1	0	1	SA139
SGA46	1	1	1	1	1	1	1	1	1	0	SA140
SGA47	1	1	1	1	1	1	1	1	1	1	SA141

Flash Memory Autoselect Codes

Type	A ₂₁ to A ₁₂	A ₆	A ₃	A ₂	A ₁	A ₀	Code (HEX)
Manufacture's Code	BA	L	L	L	L	L	04h
Device Code	BA	L	L	L	L	H	227Eh
Extended Device Code *2	BA	L	H	H	H	L	2202h
	BA	L	H	H	H	H	2201h
Sector Group Protection	Sector Group Addresses	L	L	L	H	L	01h*1

Legend: L = V_{IL}, H = V_{IH}. See "■ ELECTRICAL CHARACTERISTICS (DC Characteristics) " for voltage levels.

*1 : Outputs 01h at protected sector group addresses and outputs 00h at unprotected sector group addresses.

*2 : A read cycle at address (BA) 01h outputs device code. When 227Eh was output, this indicates that there will require two additional codes, called Extended Device Codes. Therefore the system may continue reading out these Extended Device Codes at the address of (BA) 0Eh, as well as at (BA) 0Fh.

MBVD23381HJ-70

Flash Memory Command Definitions

Command Sequence	Bus Write Cycles Req'd	First Bus Write Cycle		Second Bus Write Cycle		Third Bus Write Cycle		Fourth Bus Read/Write Cycle		Fifth Bus Write Cycle		Sixth Bus Write Cycle	
		Addr.	Data	Addr.	Data	Addr.	Data	Addr.	Data	Addr.	Data	Addr.	Data
Read/Reset	1	XXXh	F0h	—	—	—	—	—	—	—	—	—	—
Read/Reset	3	555h	AAh	2AAh	55h	555h	F0h	RA	RD	—	—	—	—
Autoselect	3	555h	AAh	2AAh	55h	(BA) 555h	90h	—	—	—	—	—	—
Program	4	555h	AAh	2AAh	55h	555h	A0h	PA	PD	—	—	—	—
Program Suspend	1	BA	B0h	—	—	—	—	—	—	—	—	—	—
Program Resume	1	BA	30h	—	—	—	—	—	—	—	—	—	—
Chip Erase	6	555h	AAh	2AAh	55h	555h	80h	555h	AAh	2AAh	55h	555h	10h
Sector Erase	6	555h	AAh	2AAh	55h	555h	80h	555h	AAh	2AAh	55h	SA	30h
Erase Suspend	1	BA	B0h	—	—	—	—	—	—	—	—	—	—
Erase Resume	1	BA	30h	—	—	—	—	—	—	—	—	—	—
Extended Sector Group Protection *2	4	XXXh	60h	SPA	60h	SPA	40h	SPA	SD	—	—	—	—
Set to Fast Mode	3	555h	AAh	2AAh	55h	555h	20h	—	—	—	—	—	—
Fast Program *1	2	XXXh	A0h	PA	PD	—	—	—	—	—	—	—	—
Reset from Fast Mode *1	2	BA	90h	XXXh	*4 F0h	—	—	—	—	—	—	—	—
Query	1	(BA) 55h	98h	—	—	—	—	—	—	—	—	—	—
HiddenROM Entry	3	555h	AAh	2AAh	55h	555h	88h	—	—	—	—	—	—
HiddenROM Program *3	4	555h	AAh	2AAh	55h	555h	A0h	(HRA) PA	PD	—	—	—	—
HiddenROM Exit *3	4	555h	AAh	2AAh	55h	(HRBA) 555h	90h	XXXh	00h	—	—	—	—

*1: This command is valid during Fast Mode.

*2: This command is valid while $\overline{\text{RESET}} = V_{\text{ID}}$.

*3: This command is valid during HiddenROM mode.

*4: The data "00h" is also acceptable.

(Continued)

(Continued)

- Notes:
- Address bits A_{21} to $A_{11} = X = \text{"H"}$ or "L" for all address commands except or Program Address (PA), Sector Address (SA), and Bank Address (BA), and Sector Group Address (SPA).
 - Bus operations are defined in "■ DEVICE BUS OPERATIONS".
 - RA = Address of the memory location to be read
PA = Address of the memory location to be programmed
Addresses are latched on the falling edge of the write pulse.
 - SA = Address of the sector to be erased. The combination of A_{21} , A_{20} , A_{19} , A_{18} , A_{17} , A_{16} , A_{15} , A_{14} , A_{13} , and A_{12} will uniquely select any sector.
 - BA = Bank Address (A_{21} , A_{20} , A_{19})
 - RD = Data read from location RA during read operation.
PD = Data to be programmed at location PA. Data is latched on the rising edge of write pulse.
 - SPA = Sector group address to be protected. Set sector group address and $(A_6, A_3, A_2, A_1, A_0) = (0, 0, 0, 1, 0)$.
 - SD = Sector group protection verify data. Output 01h at protected sector group addresses and output 00h at unprotected sector group addresses.
 - HRA = Address of the HiddenROM area: 000000h to 00007Fh
 - HRBA = Bank Address of the HiddenROM area ($A_{21} = A_{20} = A_{19} = V_{IL}$)
 - The system should generate the following address patterns: 555h or 2AAh to addresses A_{10} to A_0
 - Both Read/Reset commands are functionally equivalent, resetting the device to the read mode.
 - The command combinations not described in this table are illegal.

MBVD23381HJ-70

2. ELECTRICAL CHARACTERISTICS (AC Characteristics)

• Read Only Operations Characteristics (Flash)

Parameter	Symbol		Condition	Value (Note)		Unit
	JEDEC	Standard		Min	Max	
Read Cycle Time	t_{AVAV}	t_{RC}	—	70	—	ns
Address to Output Delay	t_{AVQV}	t_{ACC}	$\overline{CE}f = V_{IL}$ $\overline{OE} = V_{IL}$	—	70	ns
Chip Enable to Output Delay	t_{ELQV}	t_{CEf}	$\overline{OE} = V_{IL}$	—	70	ns
Output Enable to Output Delay	t_{GLQV}	t_{OE}	—	—	30	ns
Chip Enable to Output High-Z	t_{EHQZ}	t_{DF}	—	—	25	ns
Output Enable to Output High-Z	t_{GHQZ}	t_{DF}	—	—	25	ns
Output Hold Time From Addresses, $\overline{CE}f$ or \overline{OE} , Whichever Occurs First	t_{AXQX}	t_{OH}	—	0	—	ns
\overline{RESET} Pin Low to Read Mode	—	t_{READY}	—	—	20	μs

Note : Test Conditions– Output Load : 1 TTL gate and 30 pF

Input rise and fall times : 5 ns

Input pulse levels : 0.0 V or V_{ccf}

Timing measurement reference level

Input : $0.5 \times V_{ccf}$

Output : $0.5 \times V_{ccf}$

• Read Operation Timing Diagram (Flash)

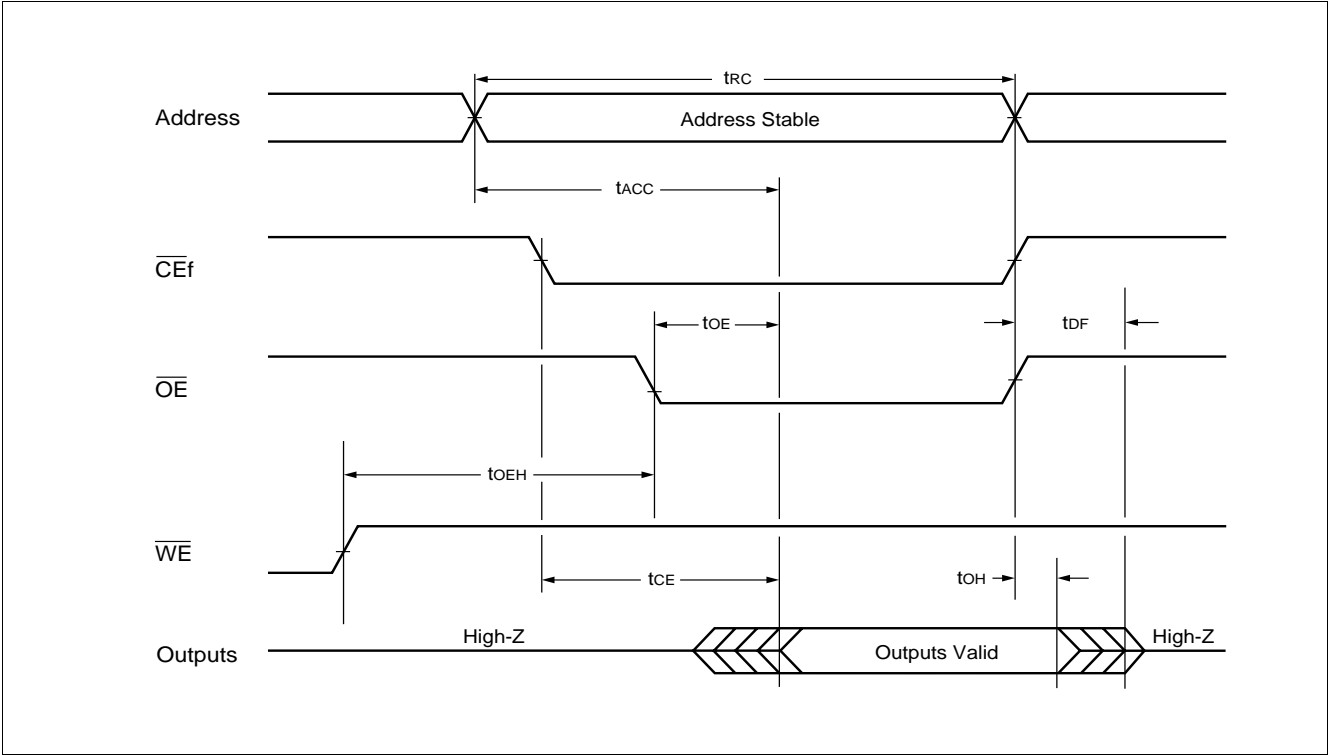

• Hardware Reset/Read Operation Timing Diagram (Flash)

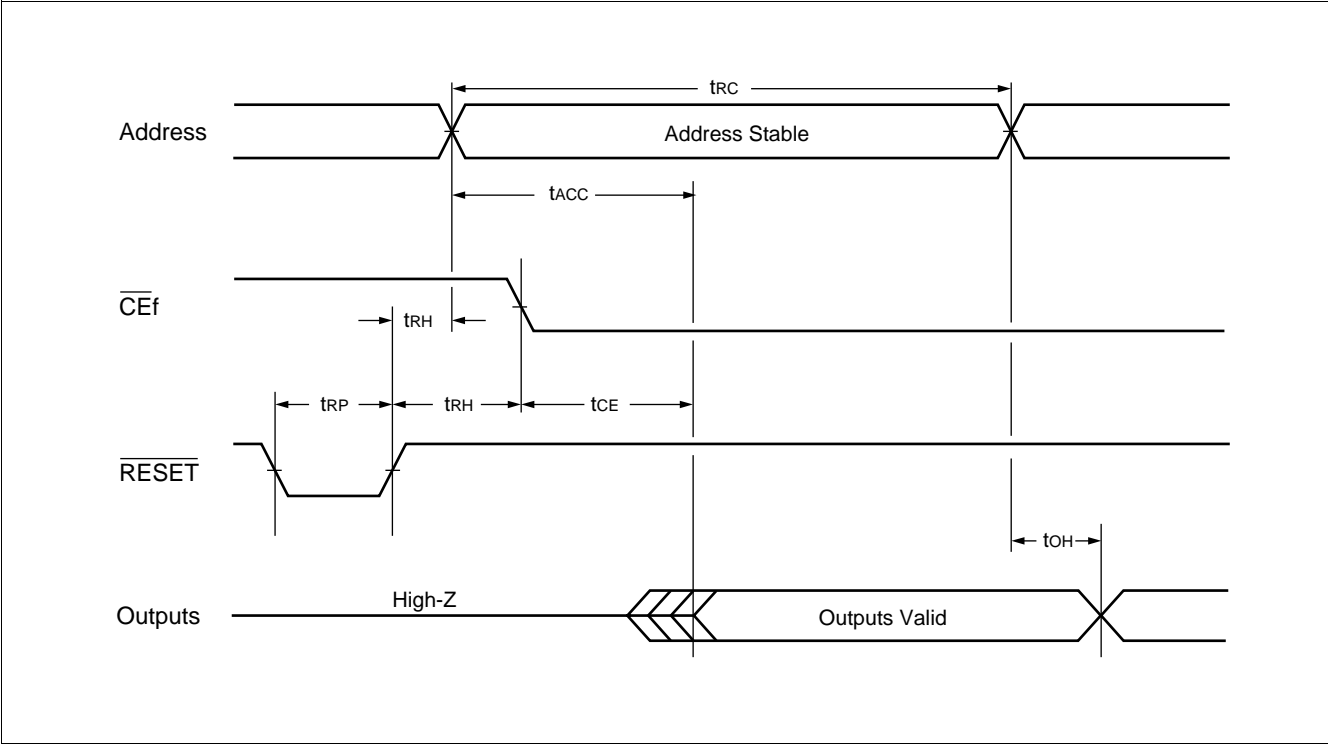

MBVD23381HJ-70

• Write/Erase/Program Operations (Flash)

Parameter	Symbol		Value			Unit
	JEDEC	Standard	Min	Typ	Max	
Write Cycle Time	t _{AVAV}	t _{WC}	70	—	—	ns
Address Setup Time	t _{AVWL}	t _{AS}	0	—	—	ns
Address Setup Time to $\overline{\text{OE}}$ Low During Toggle Bit Polling	—	t _{ASO}	12	—	—	ns
Address Hold Time	t _{WLAX}	t _{AH}	30	—	—	ns
Address Hold Time from $\overline{\text{CEf}}$ or $\overline{\text{OE}}$ High During Toggle Bit Polling	—	t _{AHT}	0	—	—	ns
Data Setup Time	t _{DVWH}	t _{DS}	25	—	—	ns
Data Hold Time	t _{WHDX}	t _{DH}	0	—	—	ns
Output Enable Hold Time	Read	t _{OEH}	0	—	—	ns
	Toggle and $\overline{\text{Data}}$ Polling		10	—	—	ns
$\overline{\text{CEf}}$ High During Toggle Bit Polling	—	t _{CEPH}	20	—	—	ns
$\overline{\text{OE}}$ High During Toggle Bit Polling	—	t _{OEPH}	20	—	—	ns
Read Recover Time Before Write	t _{GHWL}	t _{GHWL}	0	—	—	ns
Read Recover Time Before Write	t _{GHEL}	t _{GHEL}	0	—	—	ns
$\overline{\text{CEf}}$ Setup Time	t _{ELWL}	t _{CS}	0	—	—	ns
$\overline{\text{WE}}$ Setup Time	t _{WLEL}	t _{WS}	0	—	—	ns
$\overline{\text{CEf}}$ Hold Time	t _{WHEH}	t _{CH}	0	—	—	ns
$\overline{\text{WE}}$ Hold Time	t _{EHWH}	t _{WH}	0	—	—	ns
Write Pulse Width	t _{WLWH}	t _{WP}	35	—	—	ns
$\overline{\text{CEf}}$ Pulse Width	t _{ELEH}	t _{CP}	35	—	—	ns
Write Pulse Width High	t _{WHWL}	t _{WPH}	20	—	—	ns
$\overline{\text{CEf}}$ Pulse Width High	t _{EHEL}	t _{CPH}	20	—	—	ns
Programming Operation	t _{WHWH1}	t _{WHWH1}	—	6	—	μs
Sector Erase Operation *	t _{WHWH2}	t _{WHWH2}	—	0.5	—	s
V _{ccf} Setup Time	—	t _{VCS}	50	—	—	μs
Recover Time from RY/ $\overline{\text{BY}}$	—	t _{RB}	0	—	—	ns
$\overline{\text{RESET}}$ Pulse Width	—	t _{RP}	500	—	—	ns
$\overline{\text{RESET}}$ High Level Period Before Read	—	t _{RH}	200	—	—	ns
Program/Erase Valid to RY/ $\overline{\text{BY}}$ Delay	—	t _{BUSY}	—	—	90	ns
Delay Time from Embedded Output Enable	—	t _{EOE}	—	—	70	ns
Erase Time-out Time	—	t _{TOW}	50	—	—	μs
Erase Suspend Transition Time	—	t _{SPD}	—	—	20	μs

*: This does not include preprogramming time.

• Write Cycle (\overline{WE} control) (Flash)

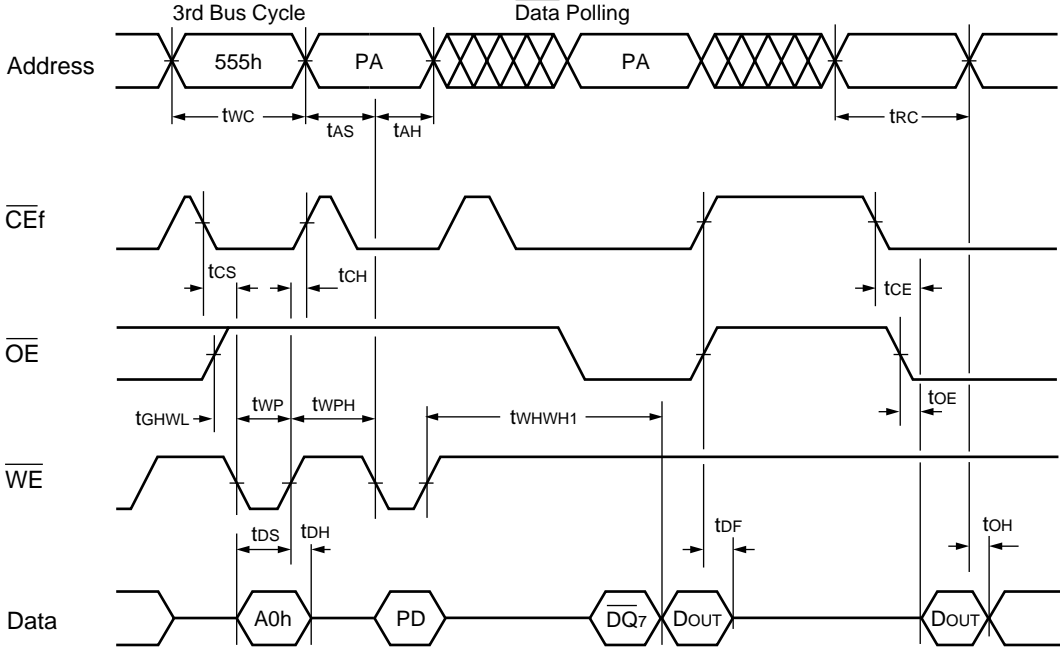

- Notes :
- PA is address of the memory location to be programmed.
 - PD is data to be programmed at word address.
 - $\overline{DQ7}$ is the output of the complement of the data written to the device.
 - D_{OUT} is the output of the data written to the device.
 - Figure indicates last two bus cycles out of four bus cycle sequence.

MBVD23381HJ-70

• Write Cycle ($\overline{\text{CEf}}$ control) (Flash)

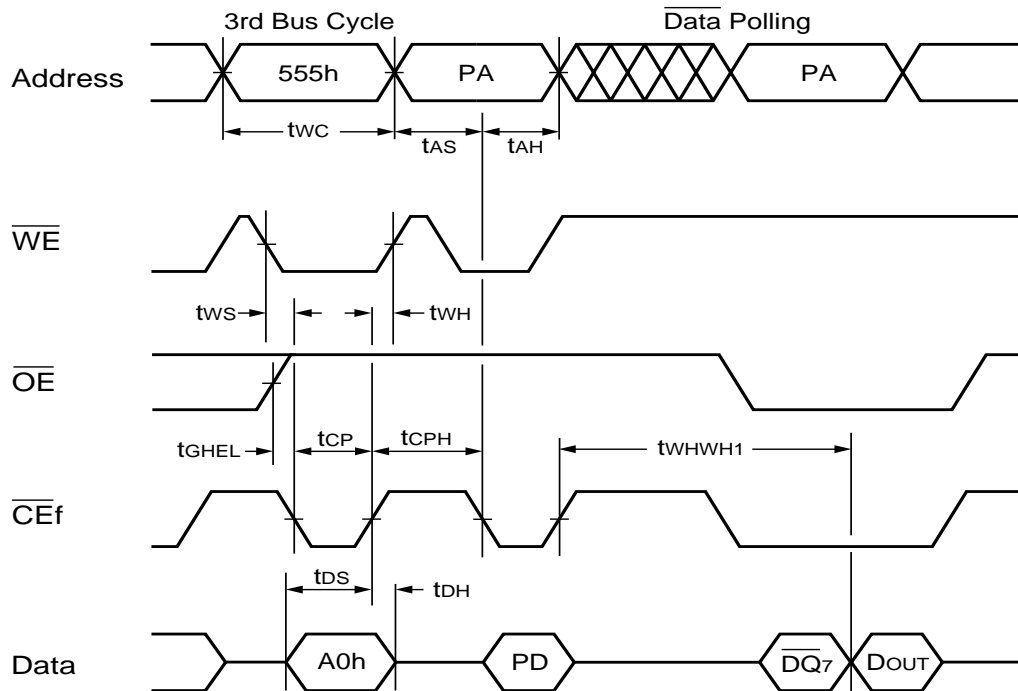

- Notes :
- PA is address of the memory location to be programmed.
 - PD is data to be programmed at word address.
 - $\overline{\text{DQ7}}$ is the output of the complement of the data written to the device.
 - DOUT is the output of the data written to the device.
 - Figure indicates last two bus cycles out of four bus cycle sequence.

• AC Waveforms Chip/Sector Erase Operations (Flash)

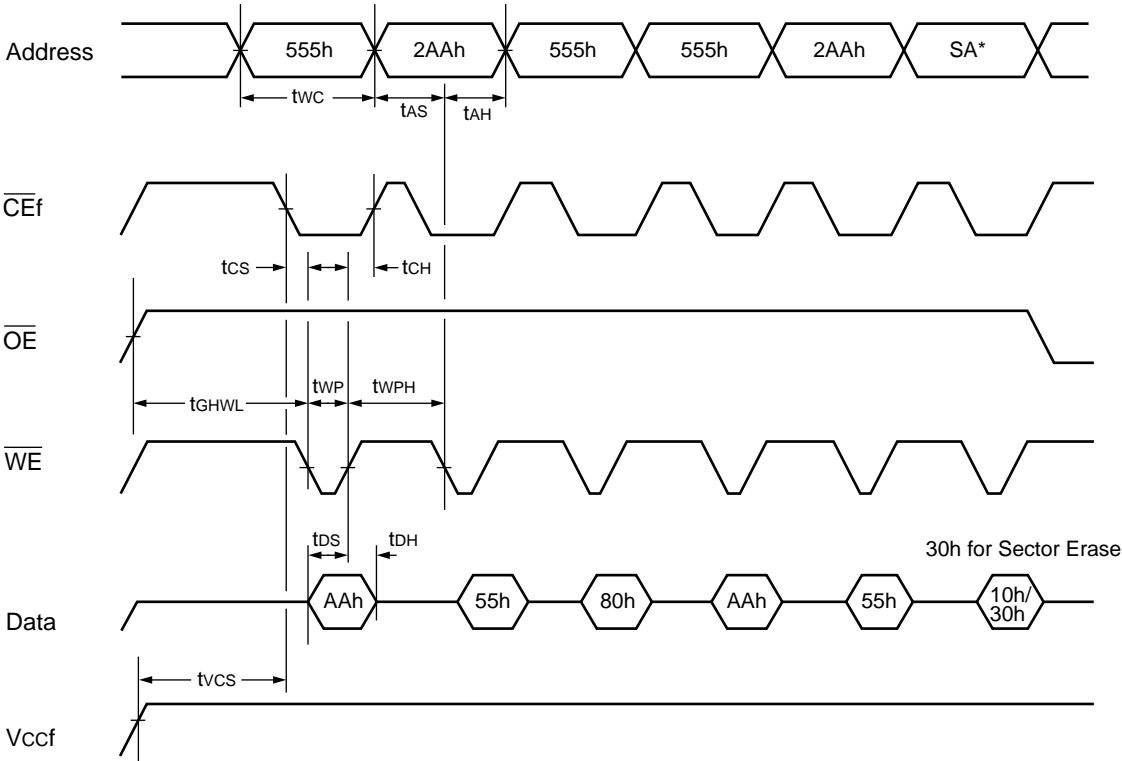

* : SA is the sector address for Sector Erase. Addresses = 555h (Word) for Chip Erase.

MBVD23381HJ-70

• AC Waveforms for $\overline{\text{Data Polling}}$ during Embedded Algorithm Operations (Flash)

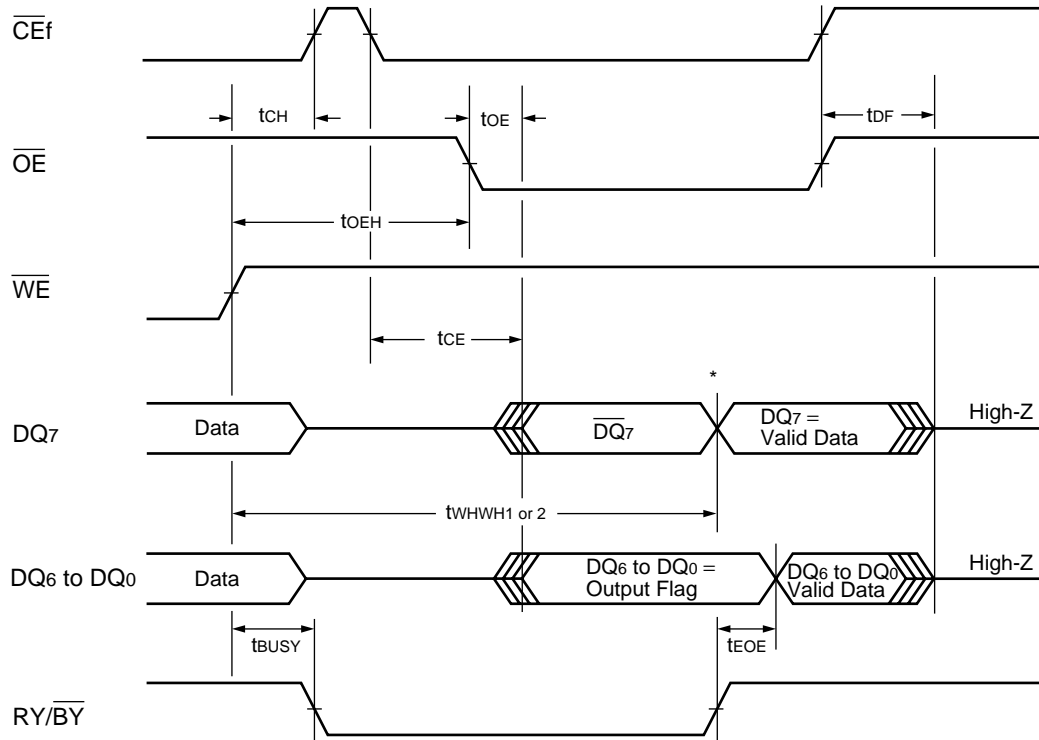

* : $\text{DQ7} = \text{Valid Data}$ (the device has completed the Embedded operation).

• AC Waveforms for Toggle Bit during Embedded Algorithm Operations (Flash)

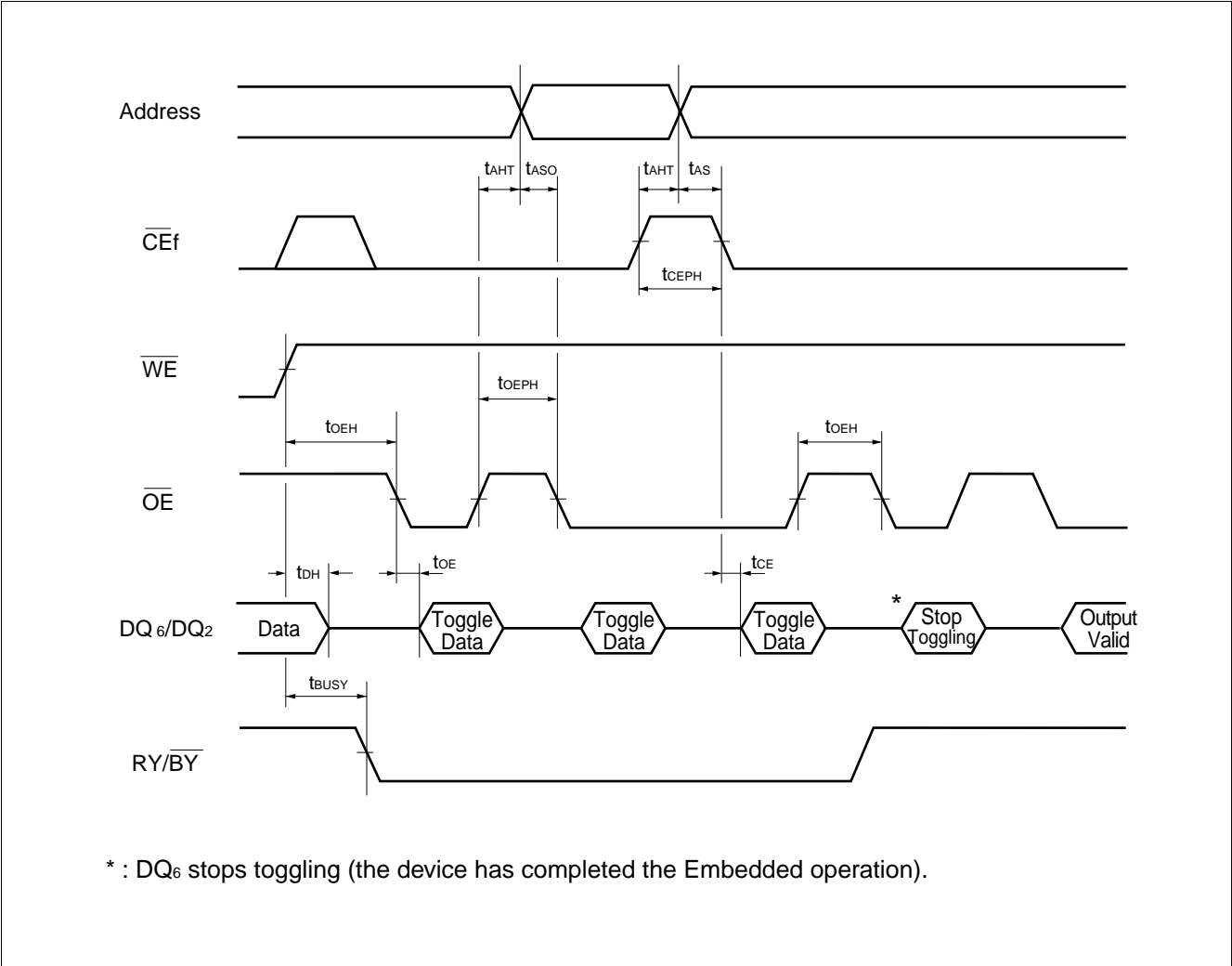

MBVD23381HJ-70

• Back-to-back Read/Write Timing Diagram (Flash)

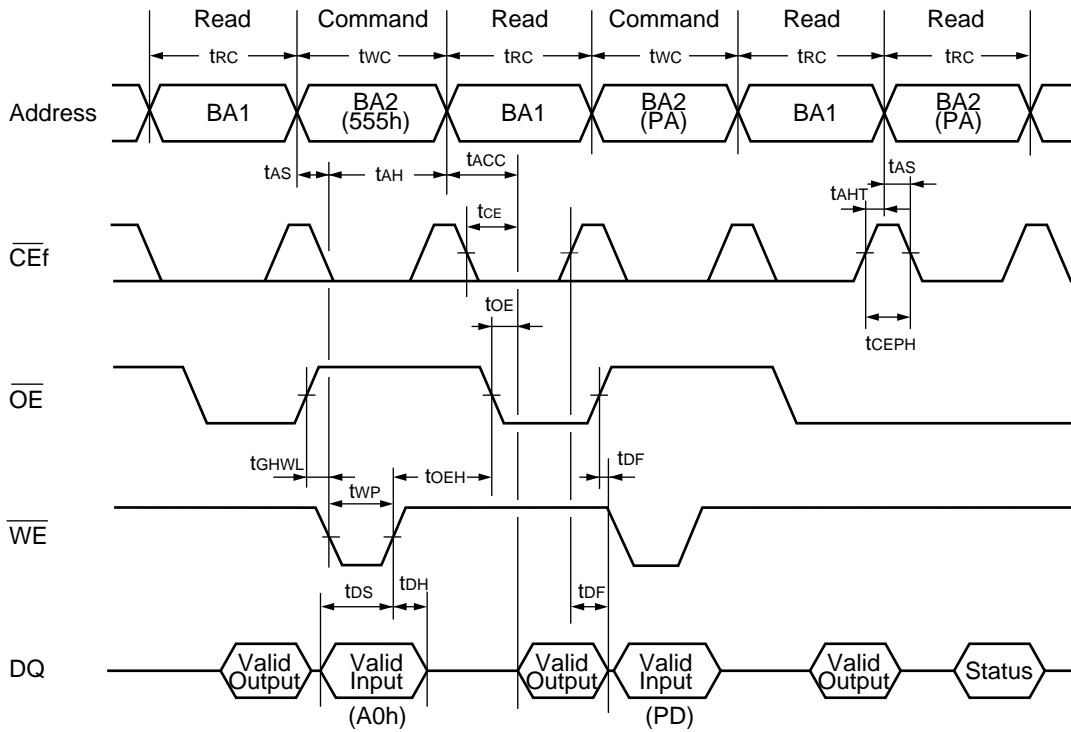

Note : This is example of Read for Bank 1 and Embedded Algorithm (program) for Bank 2.
 BA1 : Address corresponding to Bank 1
 BA2 : Address corresponding to Bank 2

• RY/BY Timing Diagram during Write/Erase Operations (Flash)

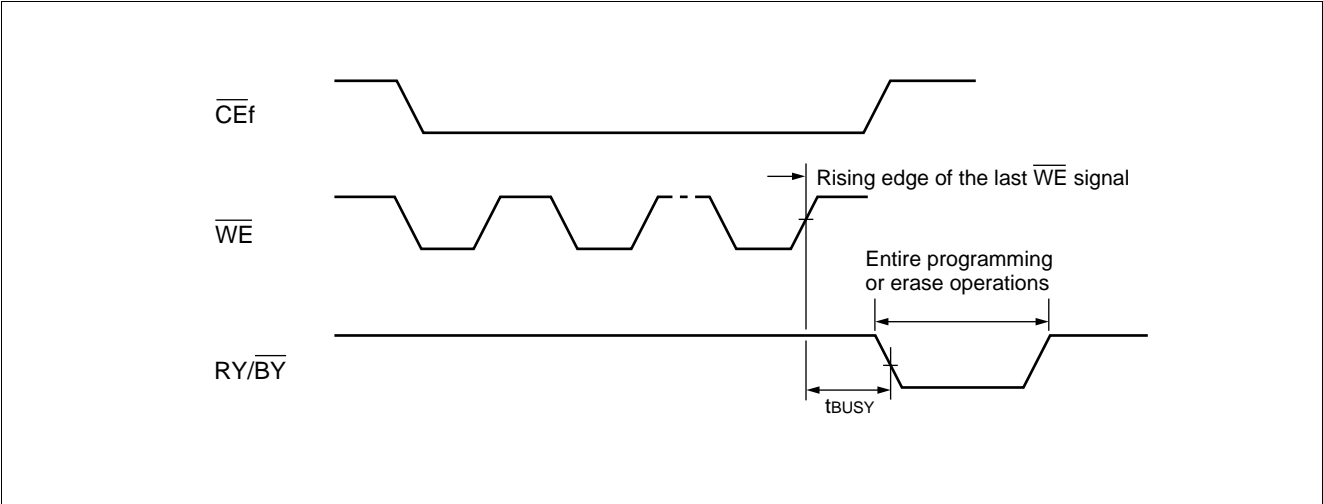

• \overline{RESET} , RY/BY Timing Diagram (Flash)

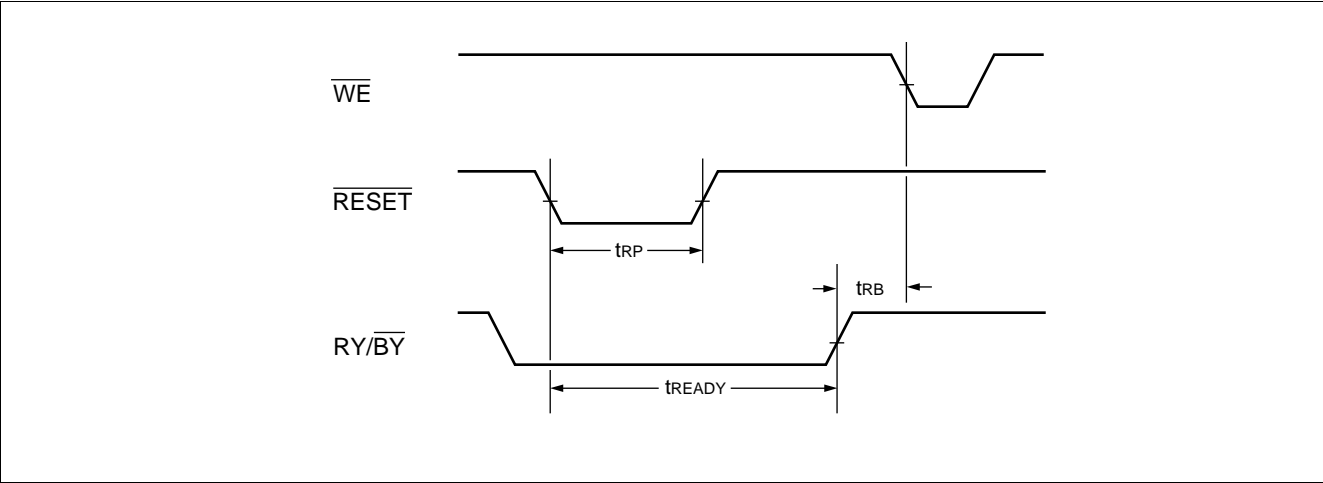

MBVD23381HJ-70

• Temporary Sector Unprotection (Flash)

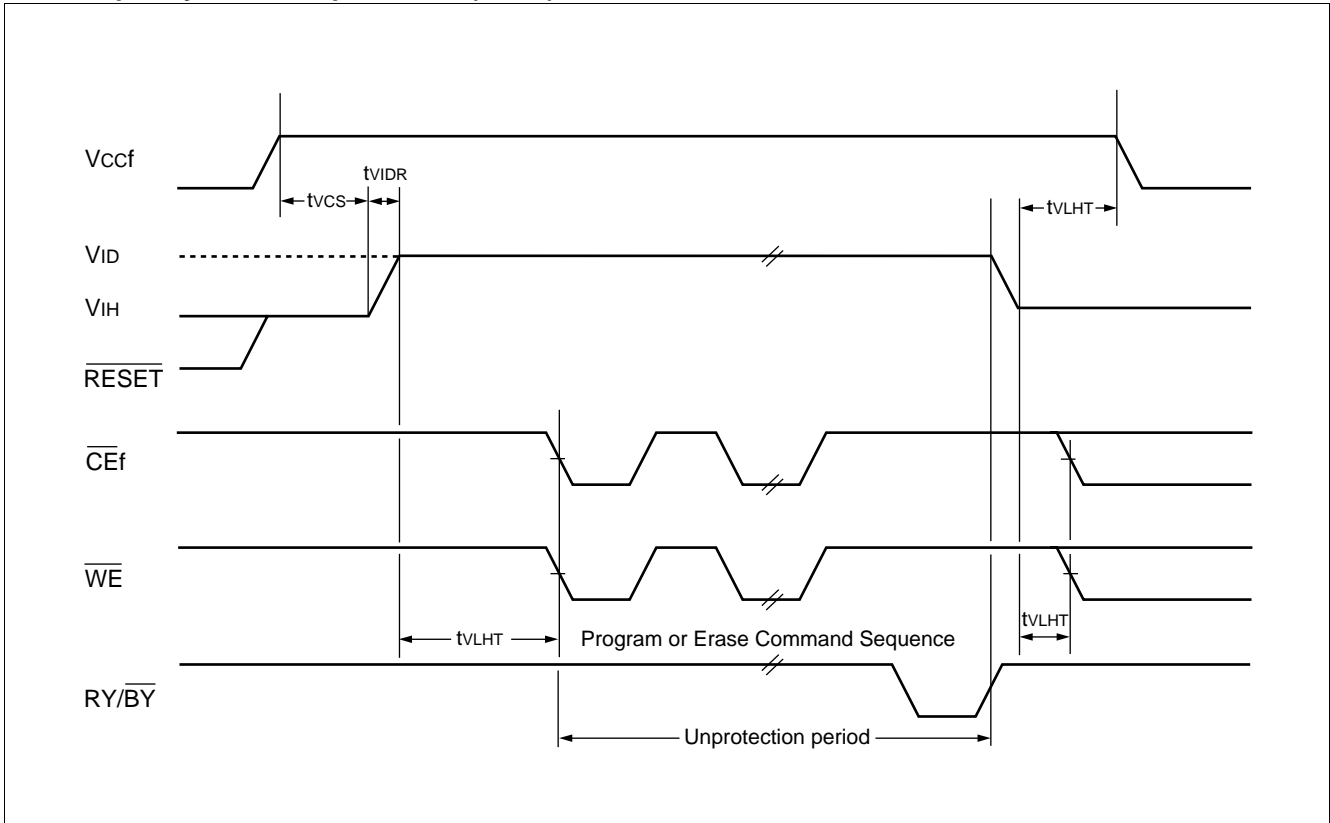

• Acceleration Mode Timing Diagram (Flash)

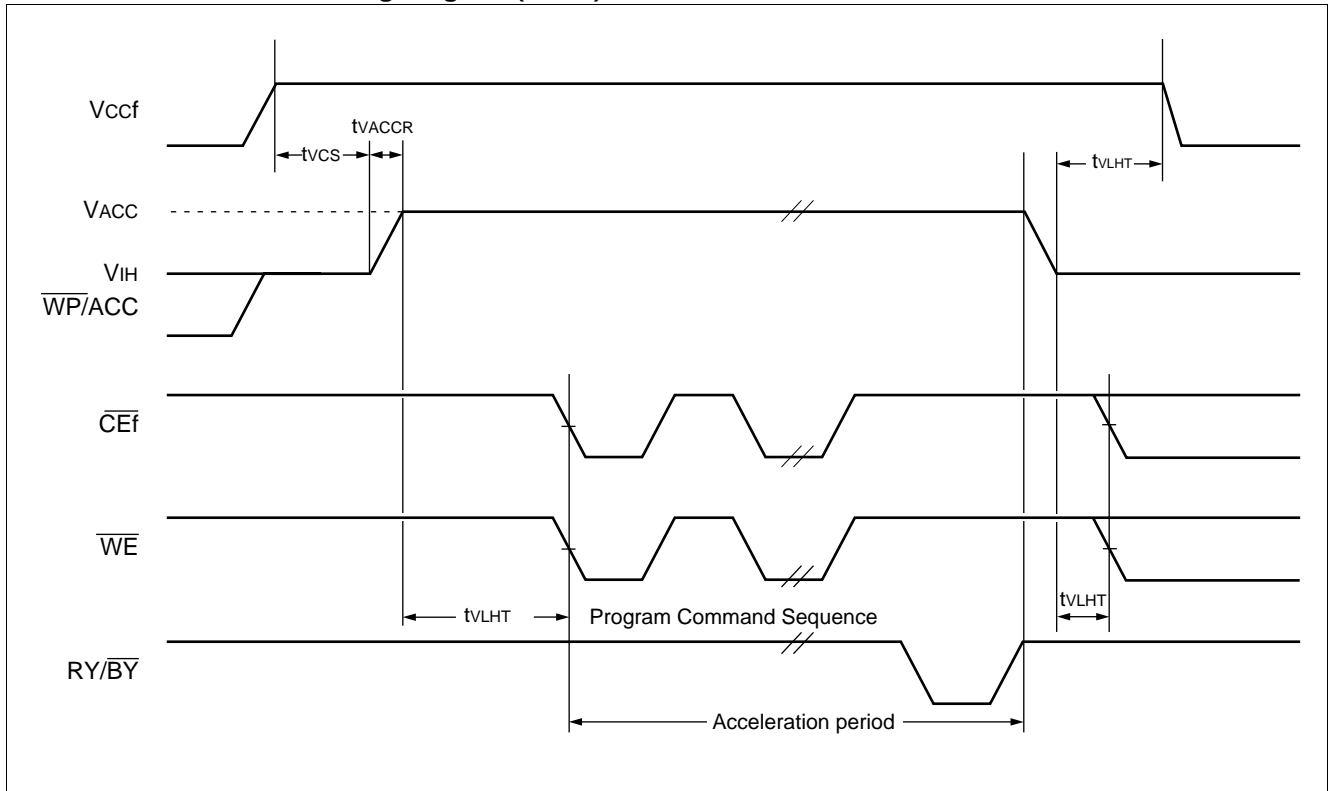

• Extended Sector Group Protection (Flash)

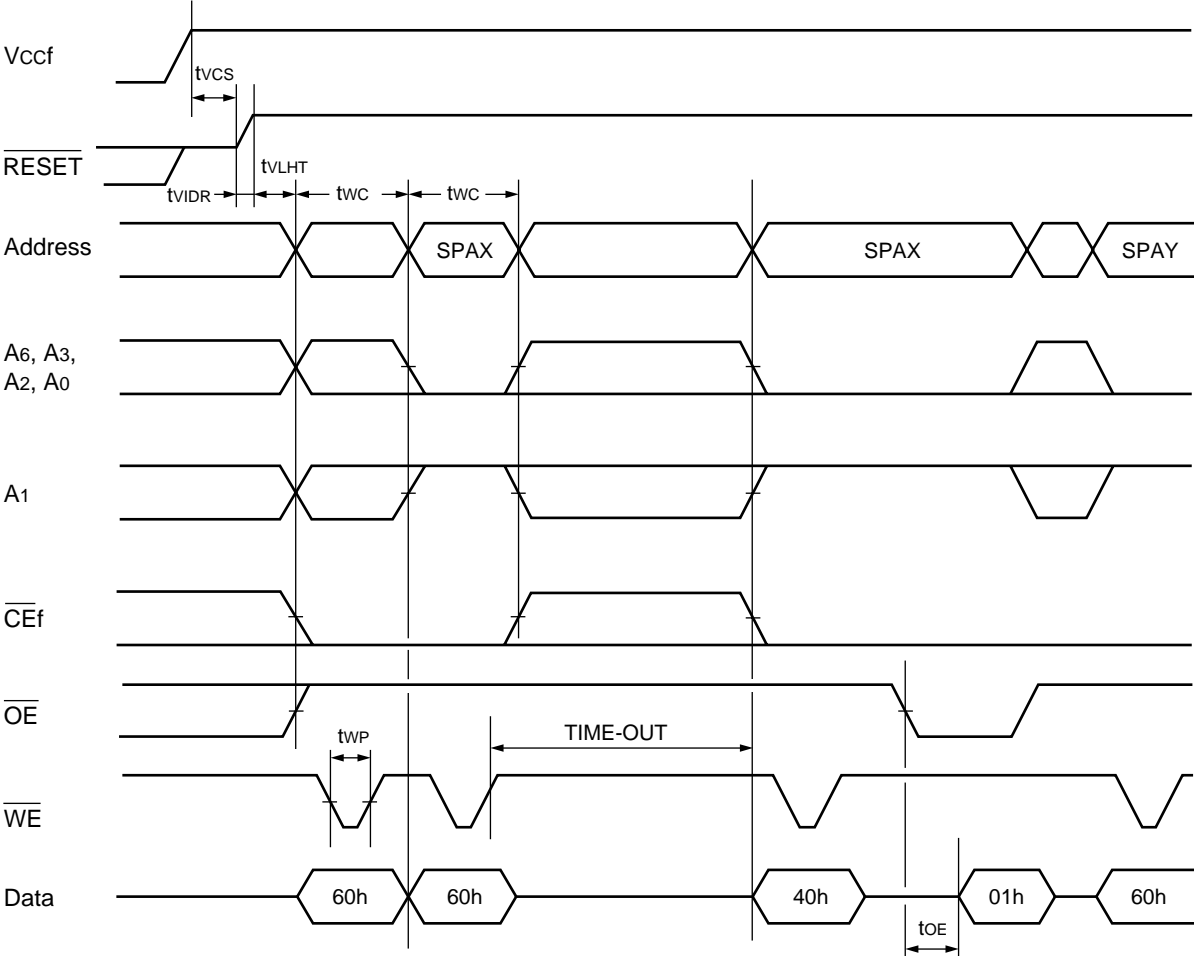

SPAX : Sector Group Address to be protected
SPAY : Next Sector Group Address to be protected
TIME-OUT : Time-Out window = 250 μs (Min)

MBVD23381HJ-70

3. ERASE AND PROGRAMMING PERFORMANCE (Flash)

Parameter	Value			Unit	Remarks
	Min	Typ	Max		
Sector Erase Time	—	0.5	2.0	s	Excludes programming time prior to erasure
Word Programming Time	—	6	100	μs	Excludes system-level overhead
Chip Programming Time	—	25.2	95	s	Excludes system-level overhead
Erase/Program Cycle	100,000	—	—	cycle	

Typical Erase conditions $T_A = +25^{\circ}\text{C}$, V_{CCf_1} & $V_{CCf_2} = 2.9\text{ V}$

Typical Program conditions $T_A = +25^{\circ}\text{C}$, V_{CCf_1} & $V_{CCf_2} = 2.9\text{ V}$

Data= Checker

■ 16M FCRAM CHARACTERISTICS FOR MCP

1. AC Characteristics

● READ OPERATION (16M FCRAM)

Parameter	Symbol	Value		Unit	Notes
		Min	Max		
Read Cycle Time	t_{RC}	80	—	ns	
Chip Enable Access Time	t_{CE}	—	60	ns	*1, *3
Output Enable Access Time	t_{OE}	—	35	ns	*1
Address Access Time	t_{AA}	—	60	ns	*1, *4
Output Data Hold Time	t_{OH}	5	—	ns	*1
$\overline{CE}1r$ Low to Output Low-Z	t_{CLZ}	5	—	ns	*2
\overline{OE} Low to Output Low-Z	t_{OLZ}	0	—	ns	*2
$\overline{CE}1r$ High to Output High-Z	t_{CHZ}	—	20	ns	*2
\overline{OE} High to Output High-Z	t_{OHZ}	—	20	ns	*2
Address Setup Time to $\overline{CE}1r$ Low	t_{ASC}	-5	—	ns	*5
Address Setup Time to \overline{OE} Low	t_{ASO}	25	—	ns	*3, *6
	$t_{ASO[ABS]}$	5	—	ns	*7
$\overline{LB} / \overline{UB}$ Setup Time to $\overline{CE}1r$ Low	t_{BSC}	-5	—	ns	*5
$\overline{LB} / \overline{UB}$ Setup Time to \overline{OE} Low	t_{BSO}	0	—	ns	
Address Invalid Time	t_{AX}	—	5	ns	*4, *8
Address Hold Time from $\overline{CE}1r$ Low	t_{CLAH}	80	—	ns	*4
Address Hold Time from \overline{OE} Low	t_{OLAH}	45	—	ns	*4, *9
Address Hold Time from $\overline{CE}1r$ High	t_{CHAH}	-5	—	ns	
Address Hold Time from \overline{OE} High	t_{OHAH}	-5	—	ns	
$\overline{LB} / \overline{UB}$ Hold Time from $\overline{CE}1r$ High	t_{CHBH}	-5	—	ns	
$\overline{LB} / \overline{UB}$ Hold Time from \overline{OE} High	t_{OHBH}	-5	—	ns	
$\overline{CE}1r$ Low to \overline{OE} Low Delay Time	t_{CLOL}	25	1000	ns	*3, *6, *9, *10
\overline{OE} Low to $\overline{CE}1r$ High Delay Time	t_{OLCH}	45	—	ns	*9
$\overline{CE}1r$ High Pulse Width	t_{CP}	10	—	ns	
\overline{OE} High Pulse Width	t_{OP}	25	1000	ns	*6, *9, *10
	$t_{OP[ABS]}$	10	—	ns	*7

*1 : The output load is 30 pF with 1 TTL.

*2 : The output load is 5 pF.

*3 : The t_{CE} is applicable if \overline{OE} is brought to Low before $\overline{CE}1r$ goes Low and is also applicable if actual value of both or either t_{ASO} or t_{CLOL} is shorter than specified value.

*4 : Applicable only to A_0 , A_1 and A_2 when both $\overline{CE}1r$ and \overline{OE} are kept at Low for the address access.

*5 : Applicable if \overline{OE} is brought to Low before $\overline{CE}1r$ goes Low.

*6 : The t_{ASO} , $t_{CLOL}(\text{Min})$ and $t_{OP}(\text{Min})$ are reference values when the access time is determined by t_{OE} .
If actual value of each parameter is shorter than specified minimum value, t_{OE} become longer by the amount of subtracting actual value from specified minimum value.
For example, if actual t_{ASO} , $t_{ASO}(\text{actual})$, is shorter than specified minimum value, $t_{ASO}(\text{Min})$, during \overline{OE} control access (ie., $\overline{CE}1r$ stays Low), the t_{OE} become $t_{OE}(\text{Max}) + t_{ASO}(\text{Min}) - t_{ASO}(\text{actual})$.

*7 : The $t_{ASO[ABS]}$ and $t_{OP[ABS]}$ is the absolute minimum value during \overline{OE} control access.

*8 : The t_{AX} is applicable when all or two addresses among A_0 to A_2 are switched from previous state.

*9 : If actual value of either t_{CLOL} or t_{OP} is shorter than specified minimum value, both t_{OLAH} and t_{OLCH} become $t_{RC}(\text{Min}) - t_{CLOL}(\text{actual})$ or $t_{RC}(\text{Min}) - t_{OP}(\text{actual})$.

*10 : Maximum value is applicable if $\overline{CE}1r$ is kept at Low.

MBVD23381HJ-70

• WRITE OPERATION (16M FCRAM)

Parameter	Symbol	Value		Unit	Notes
		Min	Max		
Write Cycle Time	t _{WC}	80	—	ns	*1
Address Setup Time	t _{AS}	0	—	ns	*2, *9
Address Hold Time	t _{AH}	35	—	ns	*2
$\overline{\text{CE}}1\text{r}$ Write Setup Time	t _{CS}	0	1000	ns	*9
$\overline{\text{CE}}1\text{r}$ Write Hold Time	t _{CH}	0	1000	ns	
$\overline{\text{WE}}$ Setup Time	t _{WS}	0	—	ns	
$\overline{\text{WE}}$ Hold Time	t _{WH}	0	—	ns	
$\overline{\text{LB}}$ and $\overline{\text{UB}}$ Setup Time	t _{BS}	-5	—	ns	
$\overline{\text{LB}}$ and $\overline{\text{UB}}$ Hold Time	t _{BH}	-5	—	ns	
$\overline{\text{OE}}$ Setup Time	t _{OES}	0	1000	ns	*3
$\overline{\text{OE}}$ Hold Time	t _{OEH}	25	1000	ns	*3, *4
	t _{OEH[ABS]}	12	—	ns	*5
$\overline{\text{OE}}$ High to $\overline{\text{CE}}1\text{r}$ Low Setup Time	t _{OHCL}	-5	—	ns	*6
$\overline{\text{OE}}$ High to Address Hold Time	t _{OHAH}	-5	—	ns	*7
$\overline{\text{CE}}1\text{r}$ Write Pulse Width	t _{CW}	45	—	ns	*1, *8
$\overline{\text{WE}}$ Write Pulse Width	t _{WP}	45	—	ns	*1, *8, *9
$\overline{\text{CE}}1\text{r}$ Write Recovery Time	t _{WRC}	20	—	ns	*1, *10
$\overline{\text{WE}}$ Write Recovery Time	t _{WR}	20	1000	ns	*1, *3, *10
Data Setup Time	t _{DS}	15	—	ns	
Data Hold Time	t _{DH}	0	—	ns	
$\overline{\text{CE}}1\text{r}$ High Pulse Width	t _{CP}	10	—	ns	*10

- *1 : Minimum value must be equal or greater than the sum of actual t_{CW} (or t_{WP}) and t_{WRC} (or t_{WR}).
- *2 : New write address is valid from either $\overline{\text{CE}}1\text{r}$ or $\overline{\text{WE}}$ is brought to High.
- *3 : The t_{OEH} is specified from end of t_{WC}(Min). The t_{OEH}(Min) is a reference value when the access time is determined by t_{OE}.
If actual value, t_{OEH}(actual) is shorter than specified minimum value, t_{OE} become longer by the amount of subtracting actual value from specified minimum value.
- *4 : The t_{OEH}(Max) is applicable if $\overline{\text{CE}}1\text{r}$ is kept at Low and both $\overline{\text{WE}}$ and $\overline{\text{OE}}$ are kept at High.
- *5 : The t_{OEH}[ABS] is the absolute minimum value if write cycle is terminated by $\overline{\text{WE}}$ and $\overline{\text{CE}}1\text{r}$ stays Low.
- *6 : t_{OHCL}(Min) must be satisfied if read operation is not performed prior to write operation.
In case $\overline{\text{OE}}$ is disabled after t_{OHCL}(Min), $\overline{\text{WE}}$ Low must be asserted after t_{trc}(Min) from $\overline{\text{CE}}1\text{r}$ Low.
In other words, read operation is initiated if t_{OHCL}(Min) is not satisfied.
- *7 : Applicable if $\overline{\text{CE}}1\text{r}$ stays Low after read operation.
- *8 : t_{CW} and t_{WP} is applicable if write operation is initiated by $\overline{\text{CE}}1\text{r}$ and $\overline{\text{WE}}$, respectively.
- *9 : If write operation is terminated by $\overline{\text{WE}}$ followed by $\overline{\text{CE}}1\text{r} = \text{H}$, the sum of actual t_{CS} and t_{WP}, and the sum of actual t_{AS} and t_{WP} must be equal or greater than 60 ns. For example, if actual t_{WP} is 45 ns, t_{CS} and t_{AS} must be equal or greater than 15 ns.
- *10 : t_{WRC} and t_{WR} is applicable if write operation is terminated by $\overline{\text{CE}}1\text{r}$ and $\overline{\text{WE}}$, respectively.
In case $\overline{\text{CE}}1\text{r}$ is brought to High before satisfaction of t_{WR}(Min), the t_{WRC}(Min) is also applied.

• **POWER DOWN PARAMETERS (16M FCRAM)**

Parameter	Symbol	Value		Unit	Note
		Min	Max		
CE2r Low Setup Time for Power Down Entry	t _{CSP}	10	—	ns	
CE2r Low Hold Time after Power Down Entry	t _{C2LP}	80	—	ns	
$\overline{\text{CE}}1\text{r}$ High Hold Time following CE2r High after Power Down Exit	t _{CHH}	350	—	μs	
$\overline{\text{CE}}1\text{r}$ High Setup Time following CE2r High after Power Down Exit	t _{CHS}	10	—	ns	

• **OTHER TIMING PARAMETERS (16M FCRAM)**

Parameter	Symbol	Value		Unit	Note
		Min	Max		
$\overline{\text{CE}}1\text{r}$ High to $\overline{\text{OE}}$ Invalid Time for Standby Entry	t _{CHOX}	10	—	ns	
$\overline{\text{CE}}1\text{r}$ High to $\overline{\text{WE}}$ Invalid Time for Standby Entry	t _{CHWX}	10	—	ns	*1
CE2r Low Hold Time after Power-up	t _{C2LH}	50	—	μs	*2
CE2r High Hold Time after Power-up	t _{C2HL}	50	—	μs	*3
$\overline{\text{CE}}1\text{r}$ High Hold Time following CE2r High after Power-up	t _{CHH}	350	—	μs	*2
$\overline{\text{CE}}1\text{r}$ and CE2r High Hold Time during Power-up	t _{CHHP}	400	—	μs	
Input Transition Time	t _T	1	25	ns	*4

*1 : Some data might be written into any address location if t_{CHWX}(Min) is not satisfied.

*2 : Must satisfy t_{CHH}(Min) after t_{C2LH}(Min).

*3 : Requires Power Down mode entry and exit after t_{C2HL}.

*4 : The Input Transition Time (t_T) at AC testing is 5ns as shown in below. If actual t_T is longer than 5ns, each AC specification must be relaxed accordingly.

• **AC TEST CONDITIONS (16M FCRAM)**

Symbol	Description	Test Setup	Value	Unit	Note
V _{IH}	Input High Level	—	V _{CCr}	V	
V _{IL}	Input Low Level	—	0.0	V	
V _{REF}	Input Timing Measurement Level	—	0.5 × V _{CCr}	V	
t _T	Input Transition Time	Between V _{IL} and V _{IH}	5	ns	

MBVD23381HJ-70

- READ Timing #1 (\overline{OE} Control Access) (16M FCRAM)

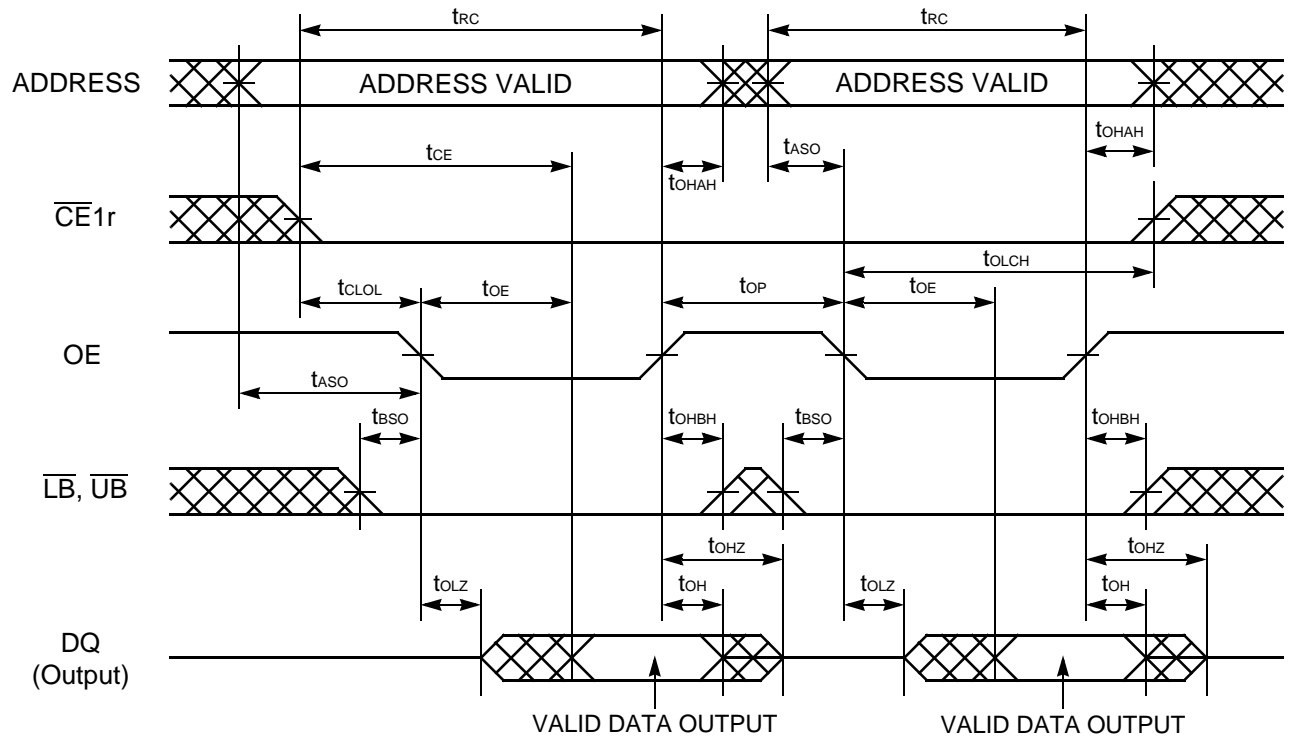

Note : $\overline{CE2r}$ and \overline{WE} must be High for entire read cycle.
 Either or both \overline{LB} and \overline{UB} must be Low when both $\overline{CE1r}$ and \overline{OE} are Low.

• READ Timing #2 ($\overline{CE1r}$ Control Access) (16M FCRAM)

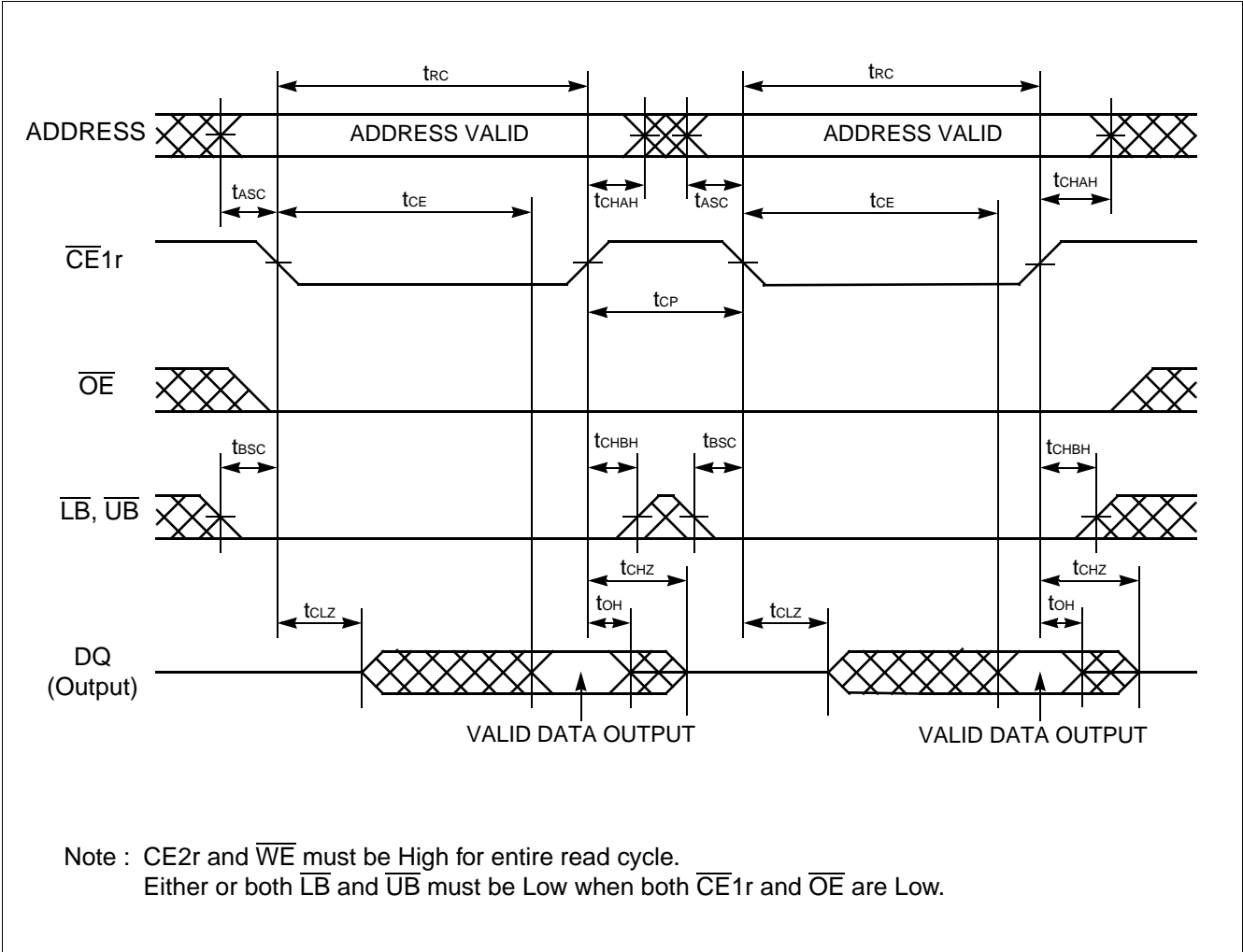

MBVD23381HJ-70

- READ Timing #3 (Address Access after \overline{OE} Control Access) (16M FCRAM)

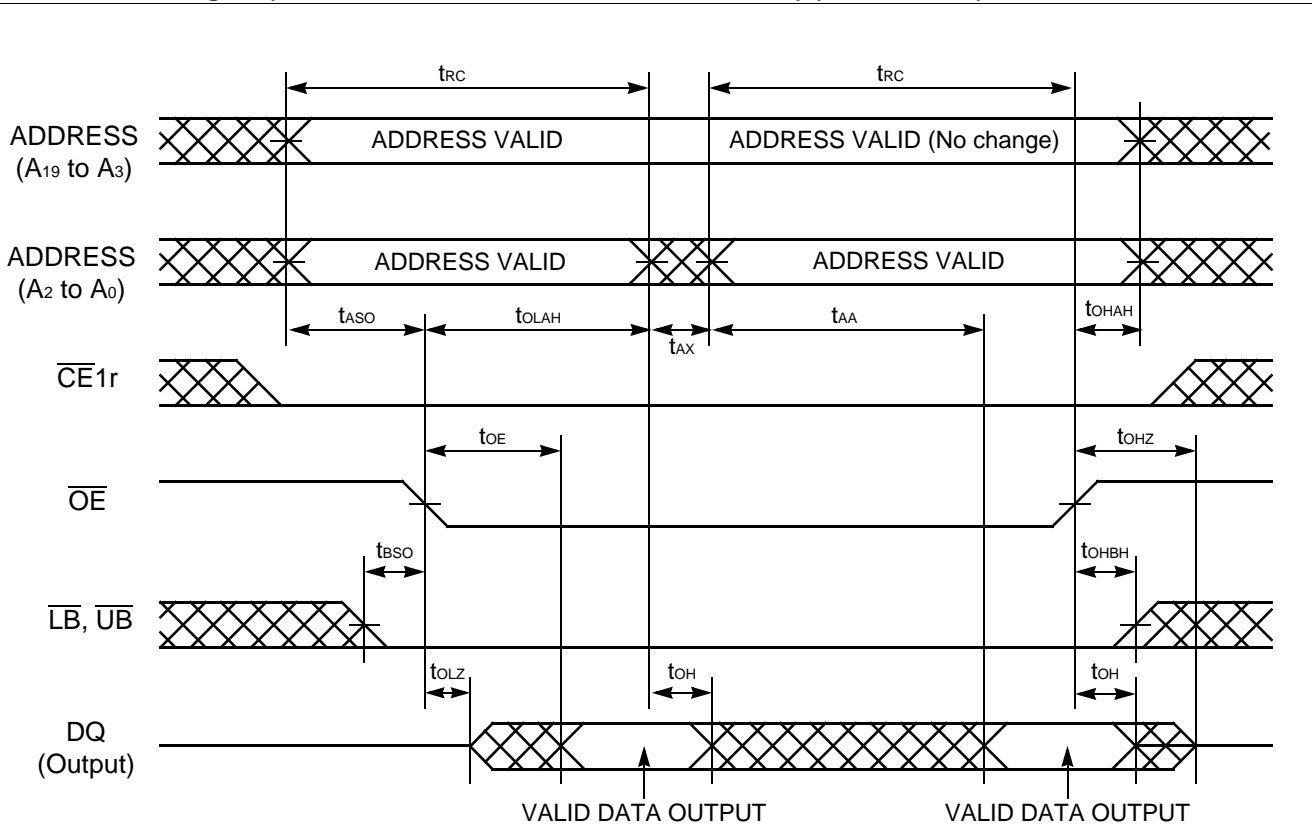

Note : $\overline{CE2r}$ and \overline{WE} must be High for entire read cycle.
 Either or both \overline{LB} and \overline{UB} must be Low when both $\overline{CE1r}$ and \overline{OE} are Low.

• **READ Timing #4 (Address Access after $\overline{CE1r}$ Control Access) (16M FCRAM)**

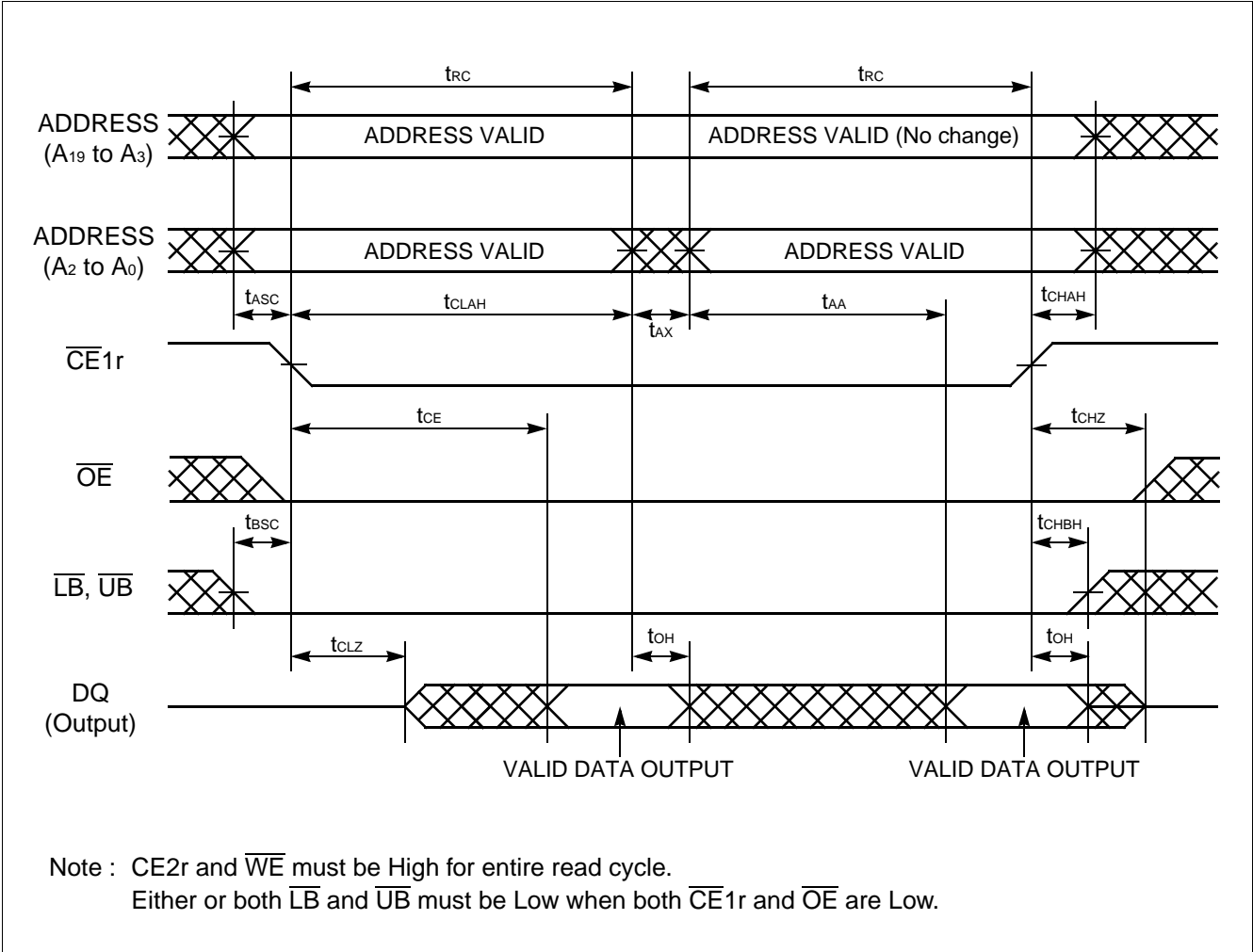

MBVD23381HJ-70

- WRITE Timing #1 ($\overline{CE1r}$ Control) (16M FCRAM)

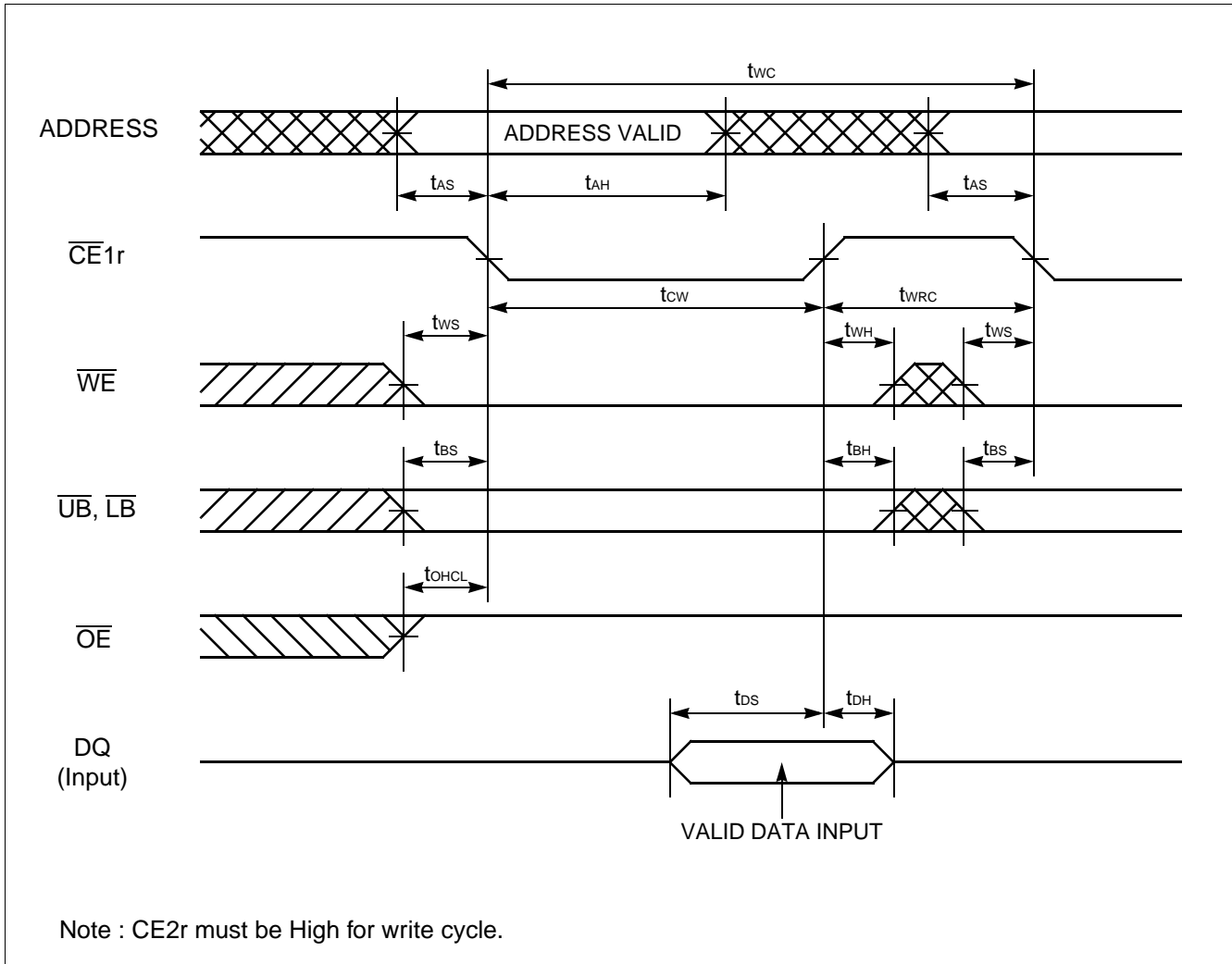

• WRITE Timing #2-1 (\overline{WE} Control, Single Write Operation) (16M FCRAM)

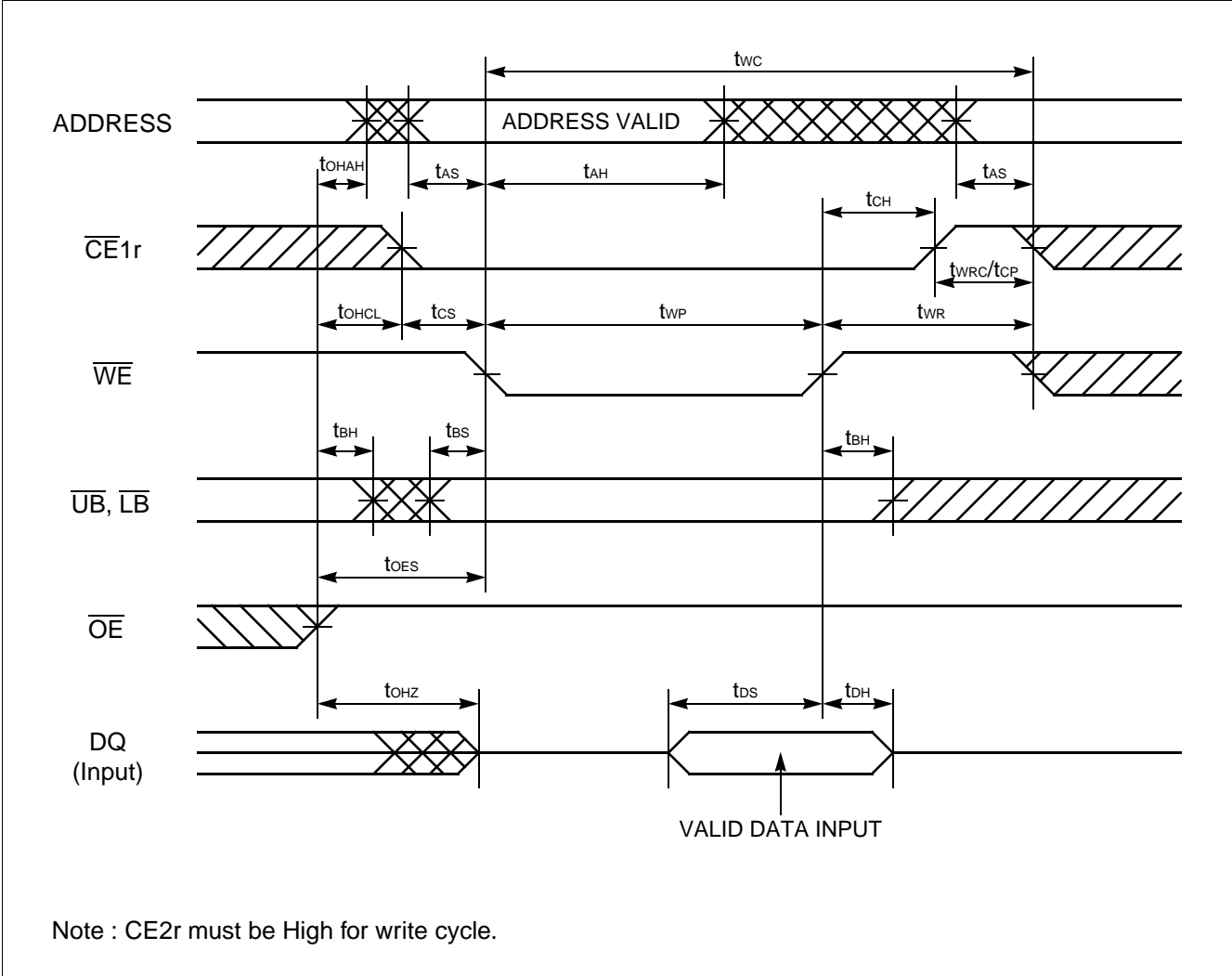

MBVD23381HJ-70

- WRITE Timing #2-2 (\overline{WE} Control, Continuous Write Operation) (16M FCRAM)

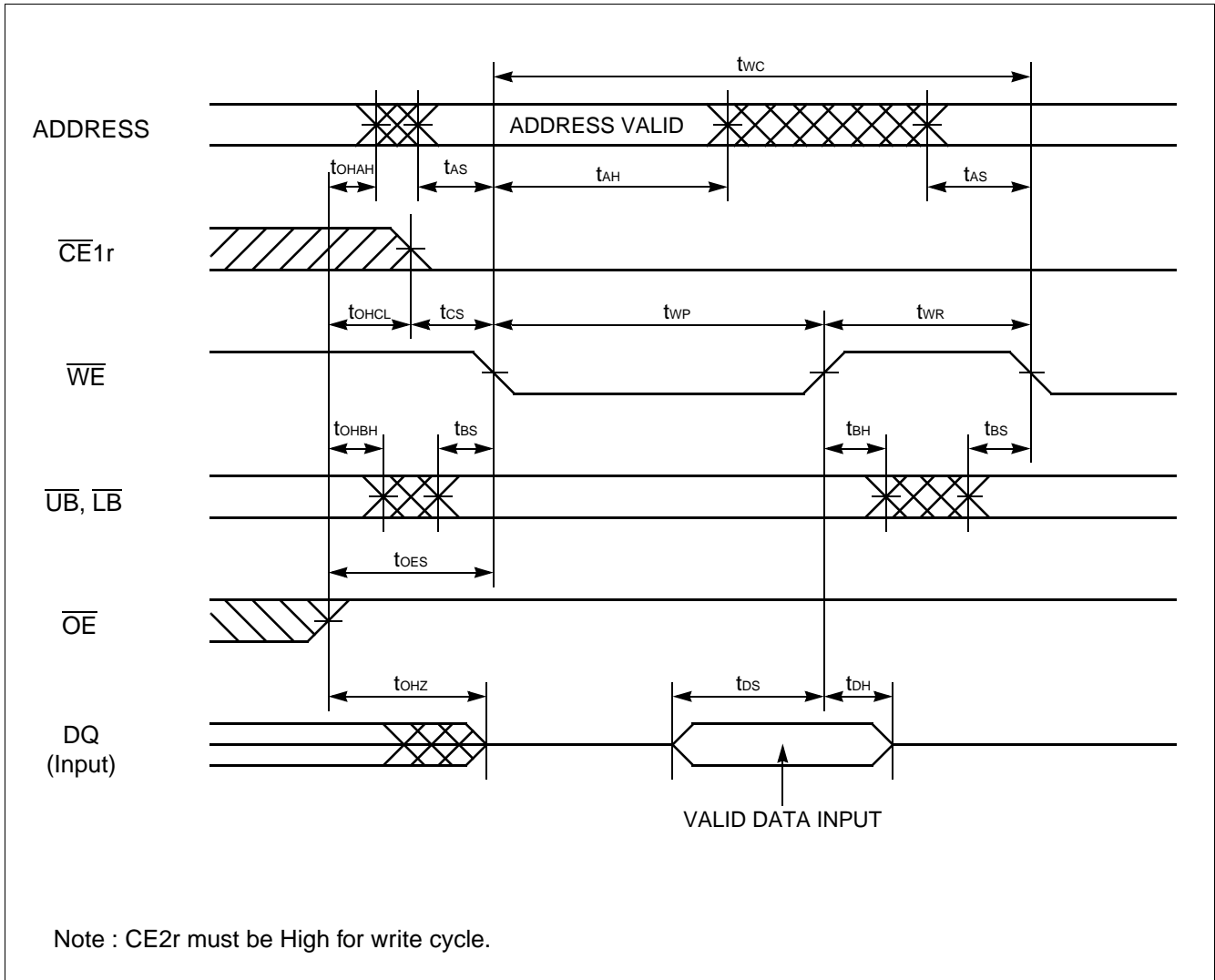

• READ / WRITE Timing #1-1 ($\overline{CE}1r$ Control) (16M FCRAM)

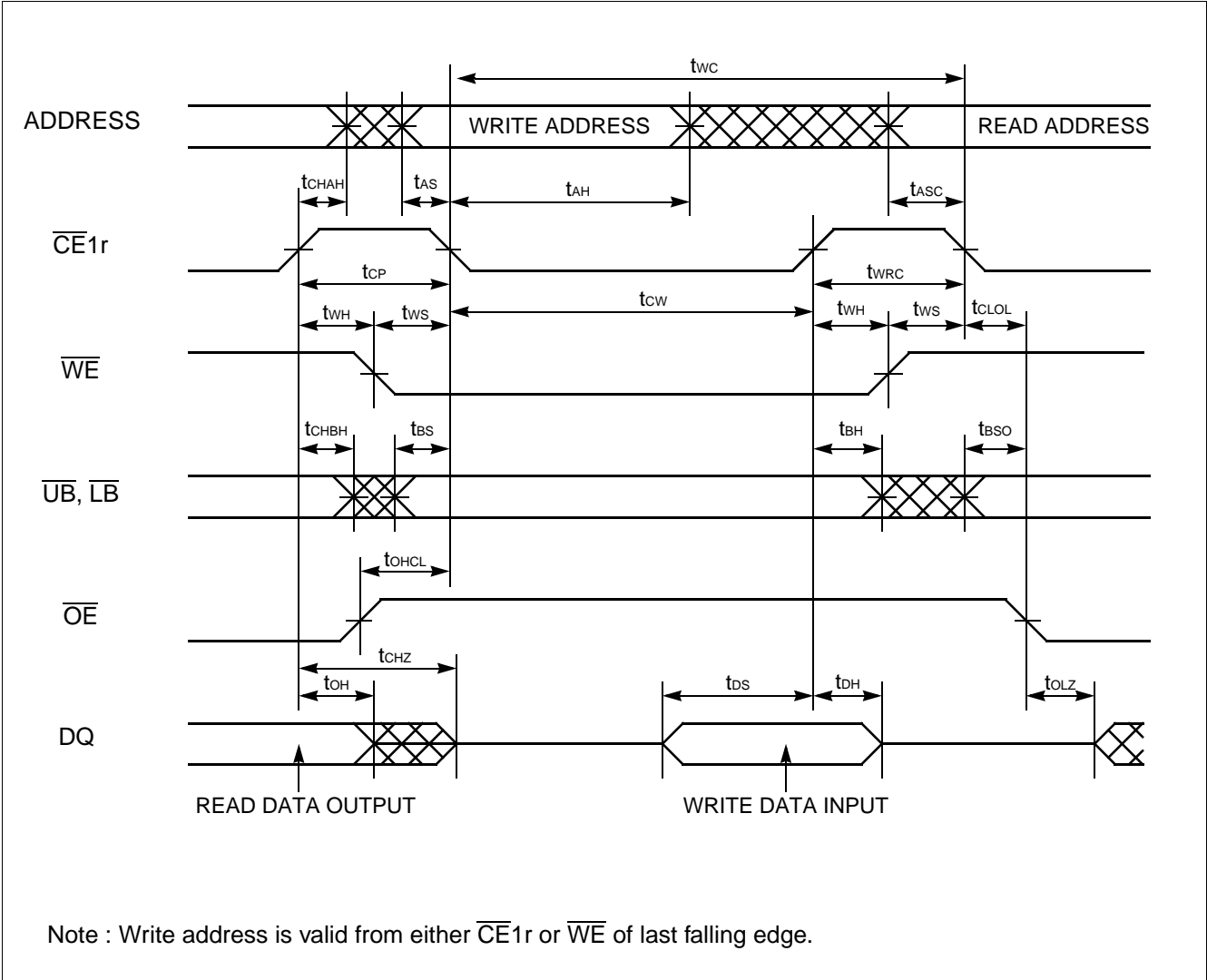

MBVD23381HJ-70

- READ / WRITE Timing #1-2 ($\overline{CE1r}$ Control) (16M FCRAM)

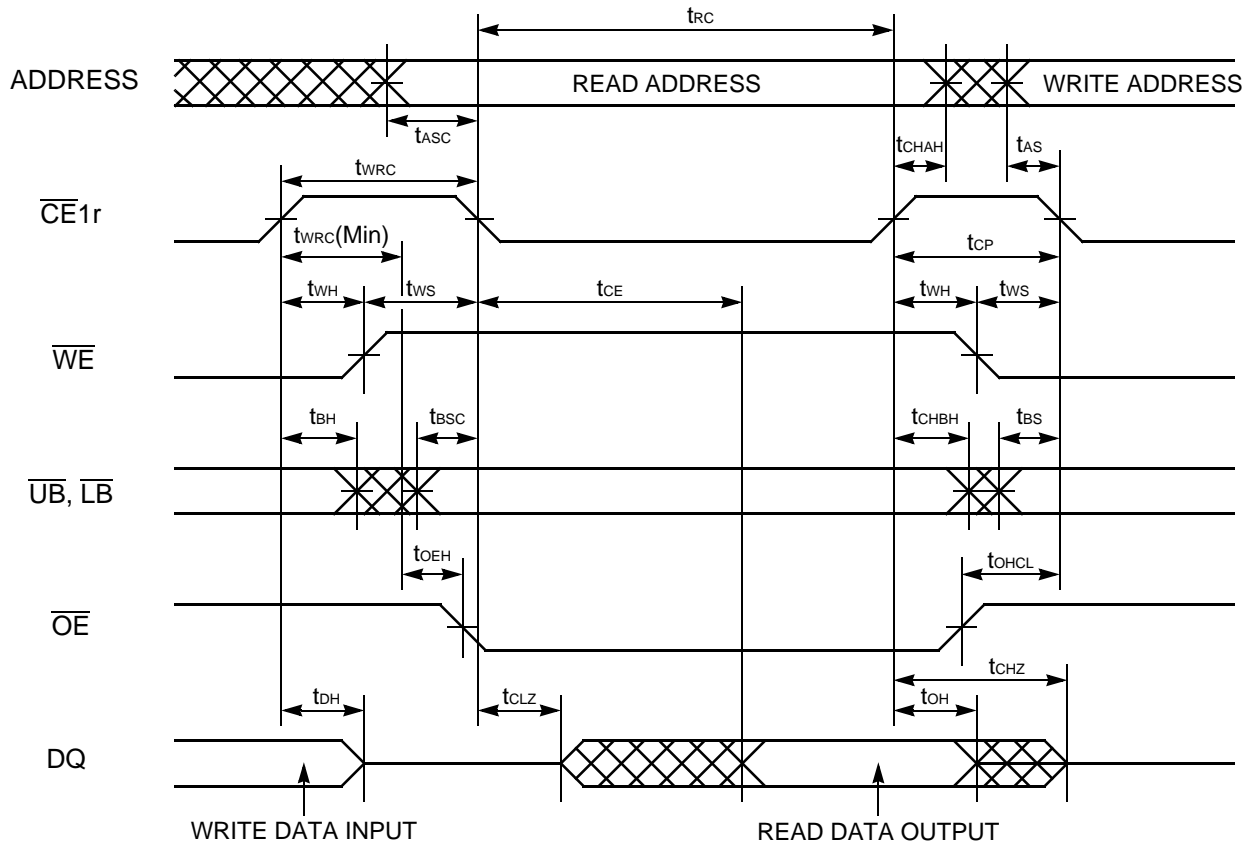

Note : The t_{OEh} is specified from the time satisfied both t_{WRC} and $t_{WR(Min)}$.

• READ (\overline{OE} Control) / WRITE (\overline{WE} Control) Timing #2-1 (16M FCRAM)

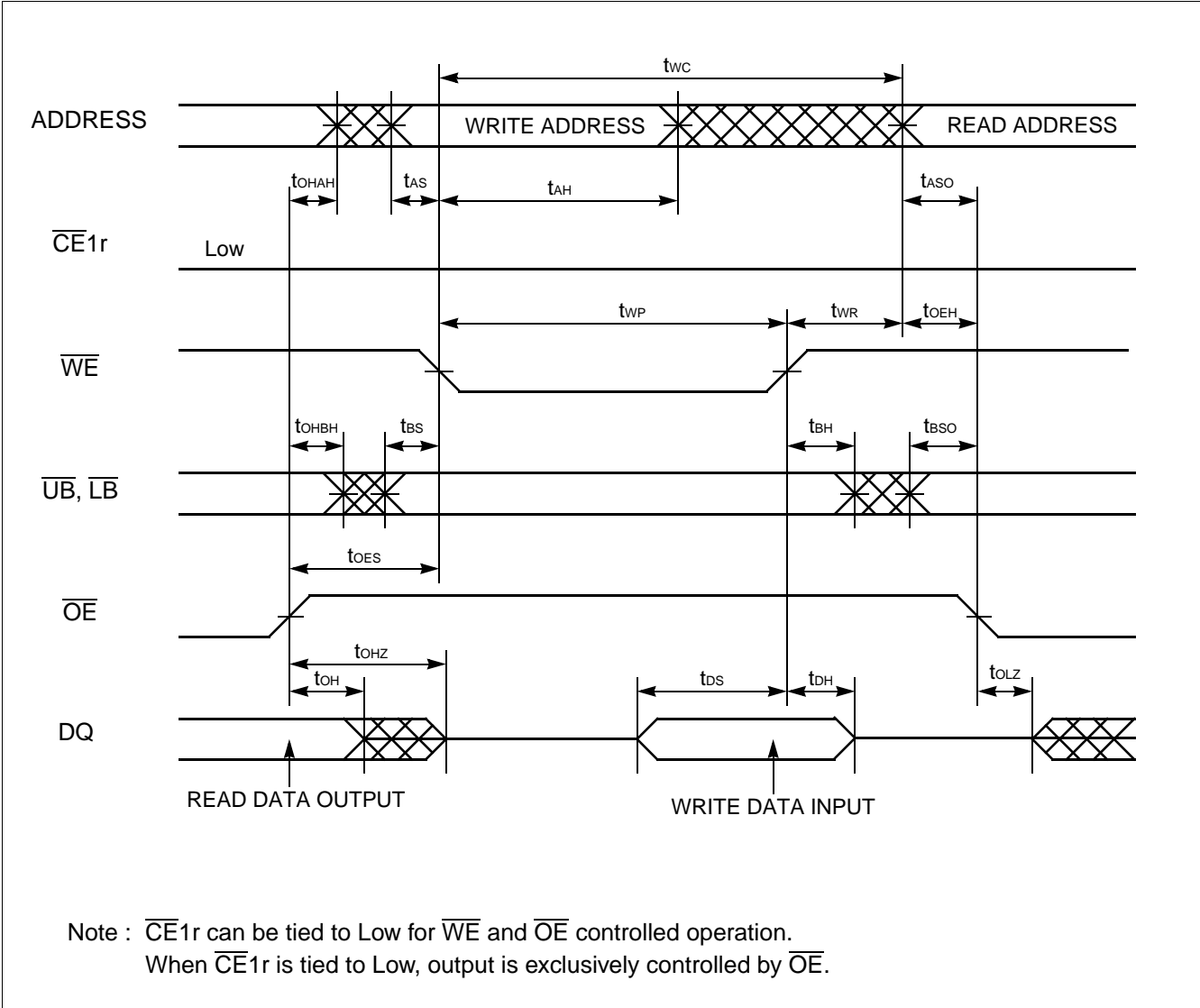

MBVD23381HJ-70

• READ (\overline{OE} Control) / WRITE (\overline{WE} Control) Timing #2-2 (16M FCRAM)

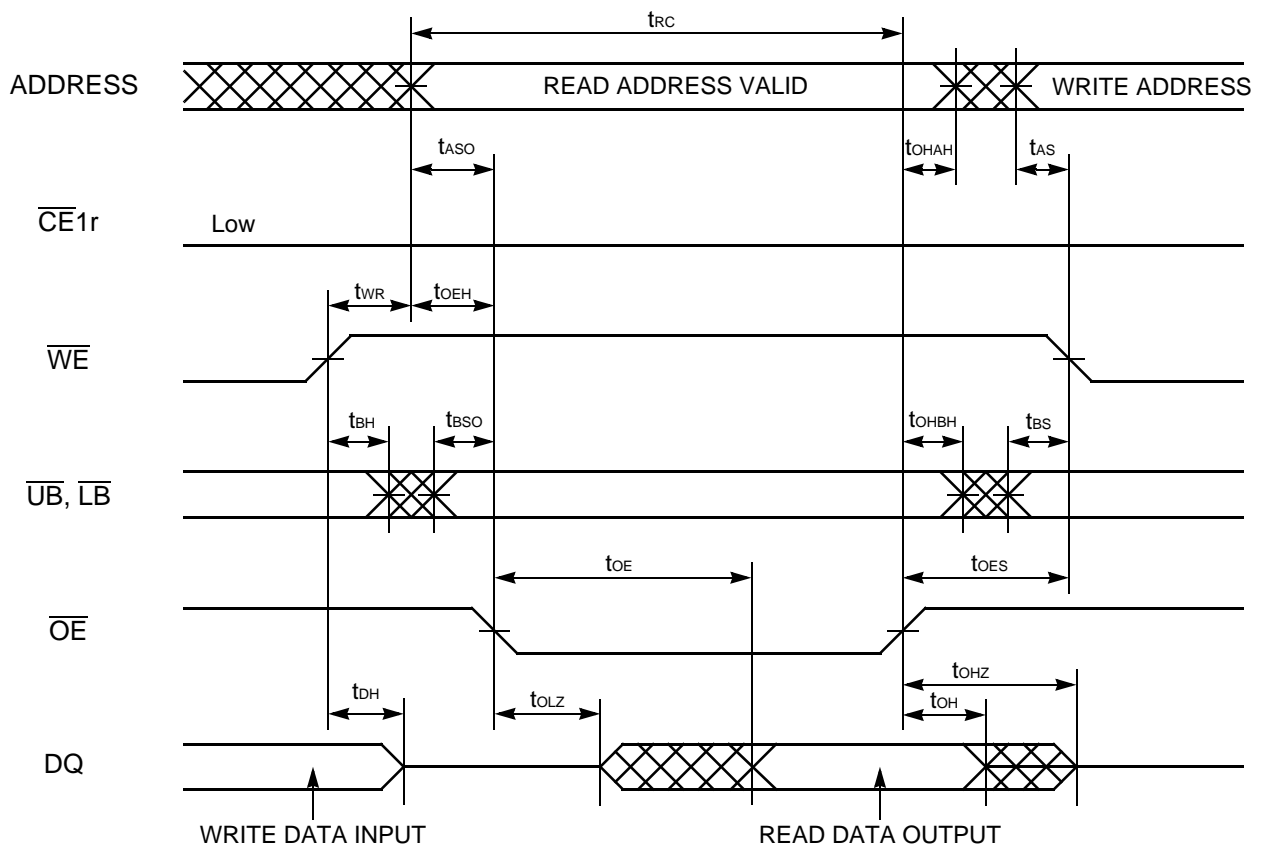

Note : $\overline{CE1r}$ can be tied to Low for \overline{WE} and \overline{OE} controlled operation.
 When $\overline{CE1r}$ is tied to Low, output is exclusively controlled by \overline{OE} .

• Standby Entry Timing after Read or Write (16M FCRAM)

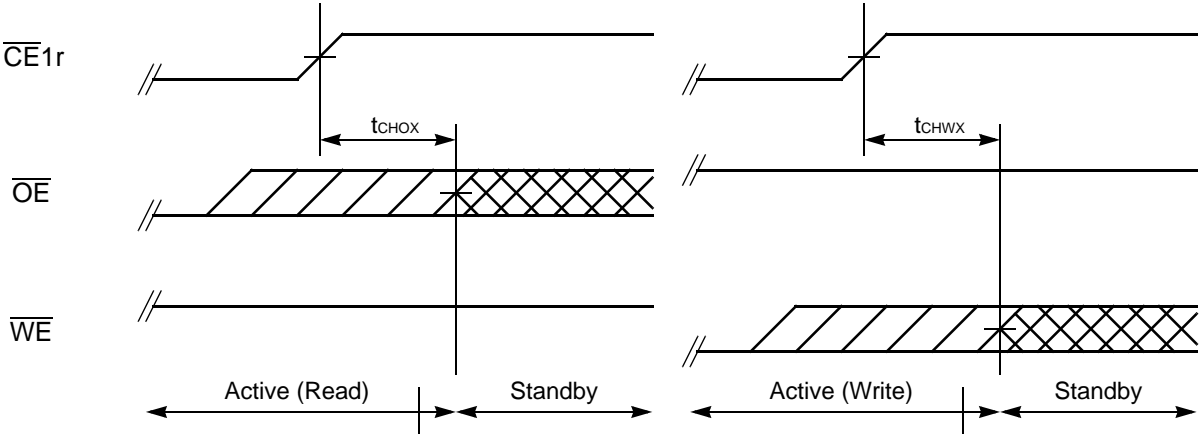

Note : Both t_{CHOX} and t_{CHWX} define the earliest entry timing for Standby mode. If either of timing is not satisfied, it takes $t_{RC}(\text{Min})$ period from either last address transition of A_0, A_1 and A_2 , or $\overline{CE}1r$ Low to High transition.

• POWER DOWN Entry and Exit Timing (16M FCRAM)

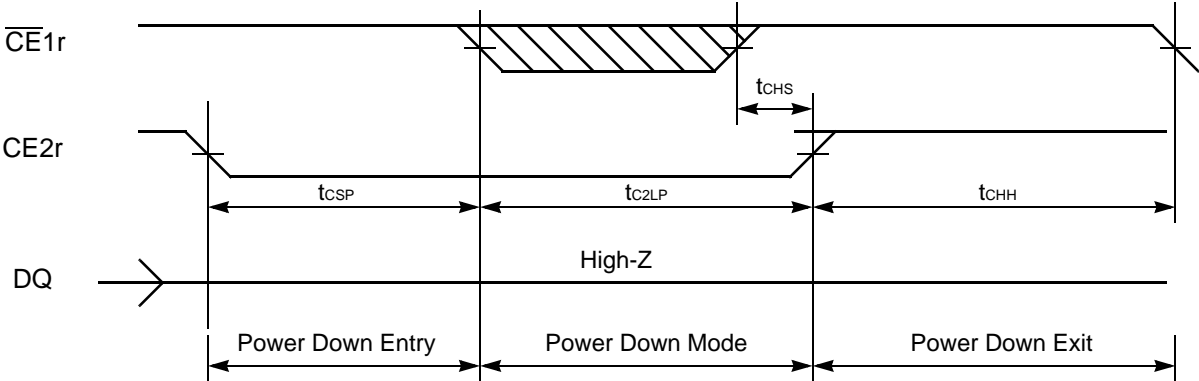

Note : This Power Down mode can be also used for Power-up #2 below.

MBVD23381HJ-70

• POWER-UP Timing #1 (16M FCRAM)

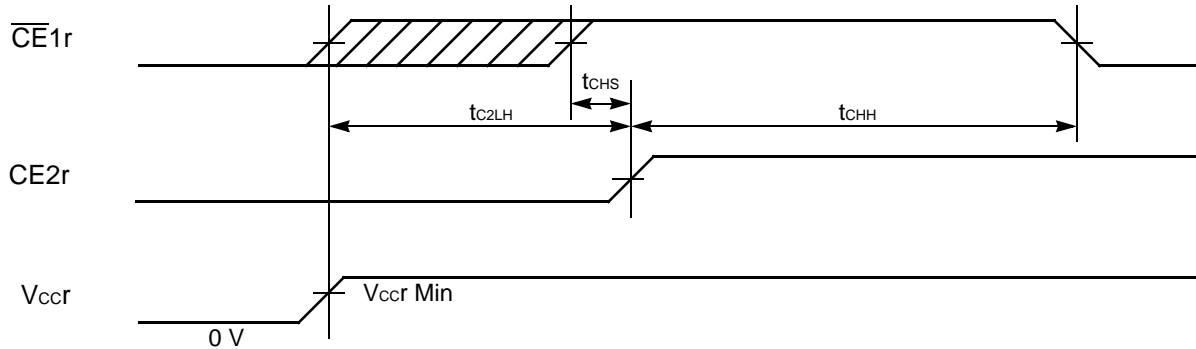

Note : The t_{c2LH} specifies after V_{ccr} reaches specified minimum level.

• POWER-UP Timing #2 (16M FCRAM)

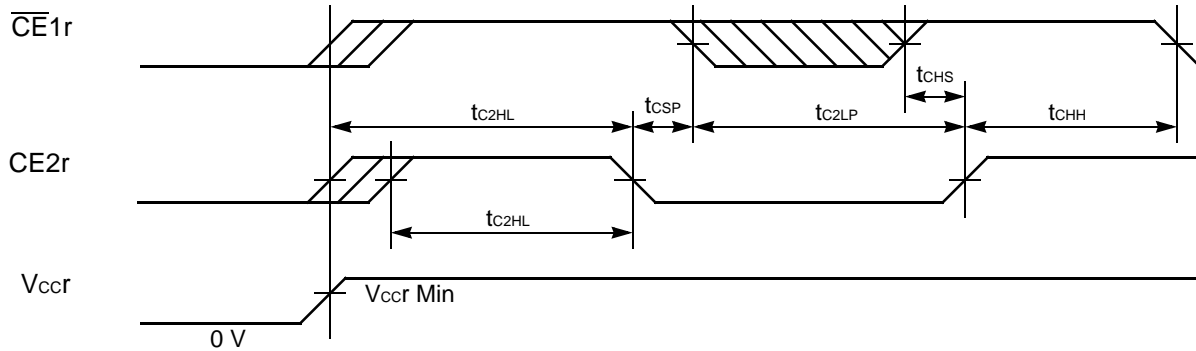

Note : The t_{c2HL} specifies from CE2r Low to High transition after V_{ccr} reaches specified minimum level. $\overline{CE1r}$ must be brought to High prior to or together with CE2r Low to High transition.

• POWER-UP Timing #3 (16M FCRAM)

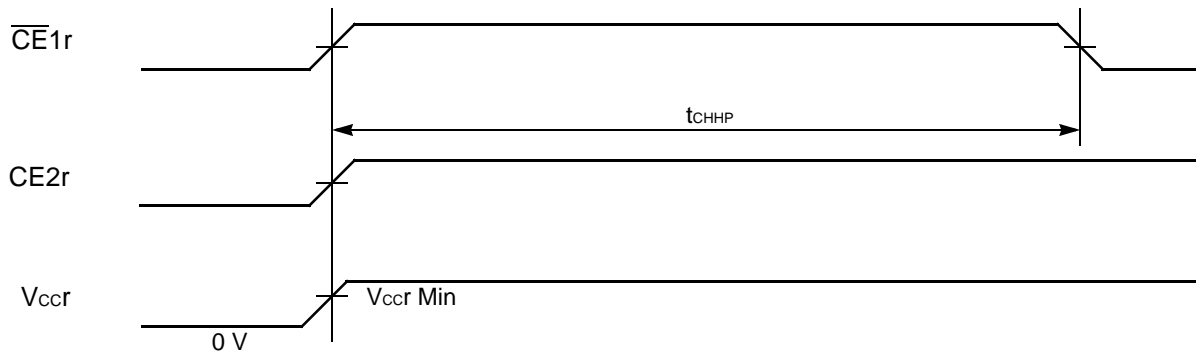

Note : Both $\overline{CE1r}$ and CE2r must be High together with V_{ccr} . Otherwise either POWER-UP Timing #1 or #2 must be used for proper operation.

2. DATA RETENTION

- Low V_{CCr} Characteristics (16M FCRAM)**

Parameter	Symbol	Test Conditions	Min	Max	Unit
V _{CCr} Data Retention Supply Voltage	V _{DRS}	$\overline{CE1r} = CE2r \geq V_{CCr} - 0.2\text{ V}$ or $\overline{CE1r} = CE2r = V_{IH}$	2.3	3.1	V
V _{CCr} Data Retention Supply Current	I _{DR1S}	V _{CCr} = V _{CCr} Max, V _{IN} ≤ 0.2 V or V _{IN} ≥ V _{CCr} - 0.2V, $\overline{CE1r} = CE2r \geq V_{CCr} - 0.2\text{ V}$, I _{OUT} = 0 mA	—	70	μs
Data Retention Setup Time	t _{DRSS}	V _{CCr} = V _{CCr} at data retention entry	0	—	ns
Data Retention Recovery Time	t _{DRRS}	V _{CCr} = V _{CCr} after data retention	100	—	ns
V _{CCr} Voltage Transition Time	ΔV/Δt	—	0.2	—	V/μs

- Data Retention Timing (16M FCRAM)**

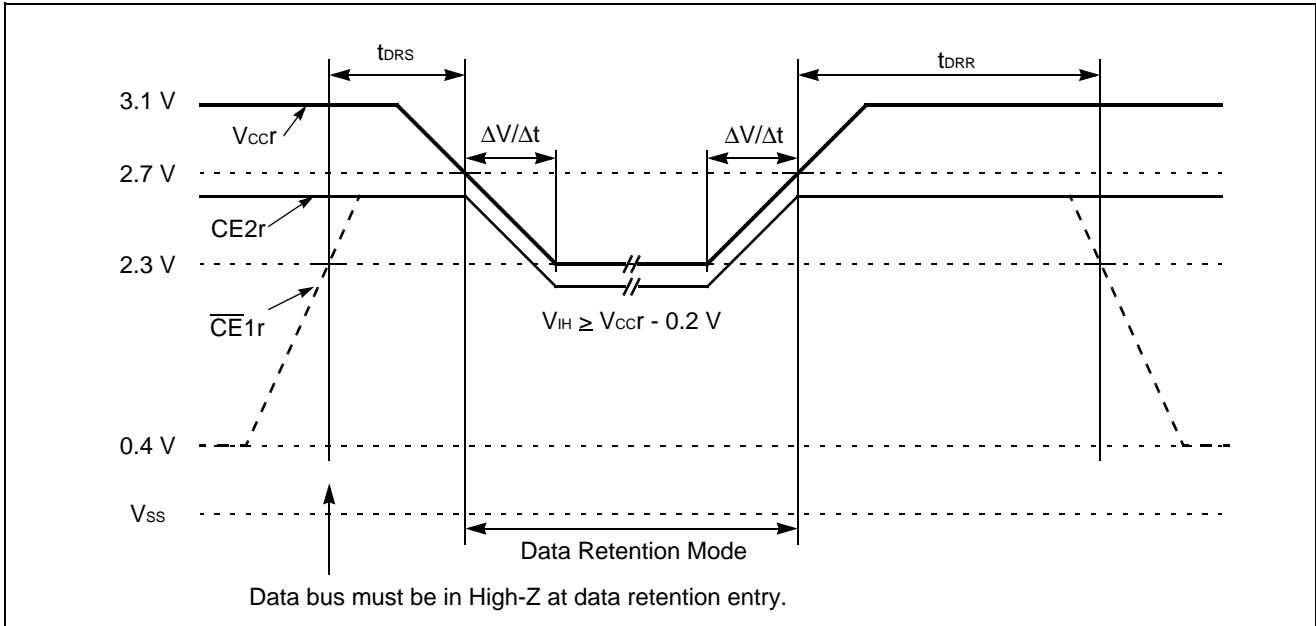

MBVD23381HJ-70

■ PIN CAPACITANCE

Parameter	Symbol	Condition	Value			Unit
			Min	Typ	Max	
Input Capacitance	C_{IN}	$V_{IN} = 0$	—	—	20.0	pF
Output Capacitance	C_{OUT}	$V_{OUT} = 0$	—	—	25.0	pF
Control Pin Capacitance	C_{IN2}	$V_{IN} = 0$	—	—	25.0	pF

Note : Test conditions $T_A = +25^{\circ}\text{C}$, $f = 1.0\text{ MHz}$

■ HANDLING OF PACKAGE

Please handle this package carefully since the sides of package create acute angles.

■ CAUTION

- The high voltage (V_{ID}) cannot apply to address pins and control pins except $\overline{\text{RESET}}$. Exception is when autoselect and sector group protect function are used, then the high voltage (V_{ID}) can be applied to $\overline{\text{RESET}}$.
- Without the high voltage (V_{ID}), sector group protection can be achieved by using "Extended Sector Group Protection" command at Table "Flash Memory Command Definitions" in "■ 64M FLASH MEMORY CHARACTERISTICS FOR MCP".

■ ORDERING INFORMATION

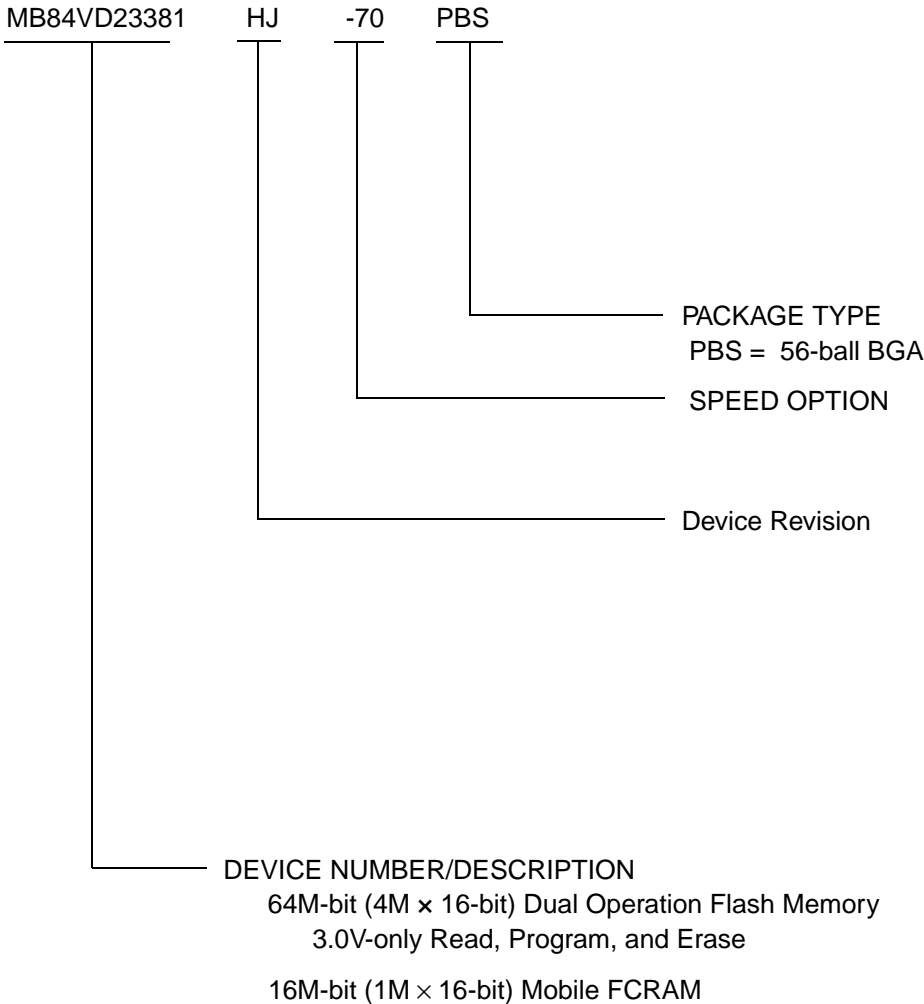

FUJITSU LIMITED

All Rights Reserved.

The contents of this document are subject to change without notice. Customers are advised to consult with FUJITSU sales representatives before ordering.

The information, such as descriptions of function and application circuit examples, in this document are presented solely for the purpose of reference to show examples of operations and uses of Fujitsu semiconductor device; Fujitsu does not warrant proper operation of the device with respect to use based on such information. When you develop equipment incorporating the device based on such information, you must assume any responsibility arising out of such use of the information. Fujitsu assumes no liability for any damages whatsoever arising out of the use of the information.

Any information in this document, including descriptions of function and schematic diagrams, shall not be construed as license of the use or exercise of any intellectual property right, such as patent right or copyright, or any other right of Fujitsu or any third party or does Fujitsu warrant non-infringement of any third-party's intellectual property right or other right by using such information. Fujitsu assumes no liability for any infringement of the intellectual property rights or other rights of third parties which would result from the use of information contained herein.

The products described in this document are designed, developed and manufactured as contemplated for general use, including without limitation, ordinary industrial use, general office use, personal use, and household use, but are not designed, developed and manufactured as contemplated (1) for use accompanying fatal risks or dangers that, unless extremely high safety is secured, could have a serious effect to the public, and could lead directly to death, personal injury, severe physical damage or other loss (i.e., nuclear reaction control in nuclear facility, aircraft flight control, air traffic control, mass transport control, medical life support system, missile launch control in weapon system), or (2) for use requiring extremely high reliability (i.e., submersible repeater and artificial satellite).

Please note that Fujitsu will not be liable against you and/or any third party for any claims or damages arising in connection with above-mentioned uses of the products.

Any semiconductor devices have an inherent chance of failure. You must protect against injury, damage or loss from such failures by incorporating safety design measures into your facility and equipment such as redundancy, fire protection, and prevention of over-current levels and other abnormal operating conditions.

If any products described in this document represent goods or technologies subject to certain restrictions on export under the Foreign Exchange and Foreign Trade Law of Japan, the prior authorization by Japanese government will be required for export of those products from Japan.