

## PLL Clock Driver for 2.5V DDR-SDRAM Memory

### Product Features

- PLL clock distribution optimized for Double Data Rate SDRAM applications.
- Distributes one differential clock input pair to ten differential clock output pairs.
- Inputs  $\overline{\text{CLK}}$ ,  $\overline{\text{CLK}}$  and  $\overline{\text{FBIN}}$ ,  $\overline{\text{FBIN}}$ : SSTL\_2
- Input PWRDWN: LVCMOS
- Outputs  $(Y_x, \overline{Y_x})$ ,  $(\overline{\text{FBOUT}}$ ,  $\overline{\text{FBOUT}}$ ): SSTL\_2
- External feedback pins  $(\overline{\text{FBIN}}$ ,  $\overline{\text{FBIN}}$ ) are used to synchronize the outputs to the clock input.
- Operates at  $\text{AV}_{\text{CC}} = 2.5\text{V}$  for core circuit and internal PLL, and  $\text{V}_{\text{DDQ}} = 2.5\text{V}$  for differential output drivers
- Package:  
Plastic 48-pin TSSOP

### Product Description

PI6CV857 PLL clock device is developed for registered DDR DIMM applications. This PLL Clock Buffer is designed for 2.5  $\text{V}_{\text{DDQ}}$  and 2.5V  $\text{AV}_{\text{CC}}$  operation and differential data input and output levels. Package options include plastic Thin Shrink Small-Outline Package (TSSOP). The device is a zero delay buffer that distributes a differential clock input pair ( $\overline{\text{CLK}}$ ,  $\overline{\text{CLK}}$ ) to ten differential pairs of clock outputs ( $Y[0:9]$ ,  $\overline{Y}[0:9]$ ) and one differential pair feedback clock outputs ( $\overline{\text{FBOUT}}$ ,  $\overline{\text{FBOUT}}$ ). The clock outputs are controlled by the input clocks ( $\overline{\text{CLK}}$ ,  $\overline{\text{CLK}}$ ), the feedback clocks ( $\overline{\text{FBIN}}$ ,  $\overline{\text{FBIN}}$ ), the 2.5V LVCMOS input (PWRDWN) and the Analog Power input ( $\text{AV}_{\text{CC}}$ ). When input PWRDWN is low while power is applied, the input receivers are disabled, the PLL is turned off and the differential clock outputs are 3-stated. When the  $\text{AV}_{\text{CC}}$  is strapped low, the PLL is turned off and bypassed for test purposes.

When the input frequency falls below a suggested detection frequency that is below the operating frequency of the PLL, the device will enter a low power mode. An input frequency detection circuit will detect the low frequency condition and perform the same low power features as when the PWRDWN input is low.

The PLL in the PI6CV857 clock driver uses input clocks ( $\overline{\text{CLK}}$ ,  $\overline{\text{CLK}}$ ) and feedback clocks ( $\overline{\text{FBIN}}$ ,  $\overline{\text{FBIN}}$ ) to provide high-performance, low-skew, low-jitter output differential clocks ( $Y[0:9]$ ,  $\overline{Y}[0:9]$ ). PI6CV857 is also able to track Spread Spectrum Clocking for reduced EMI.

### Block Diagram/Pin Configuration

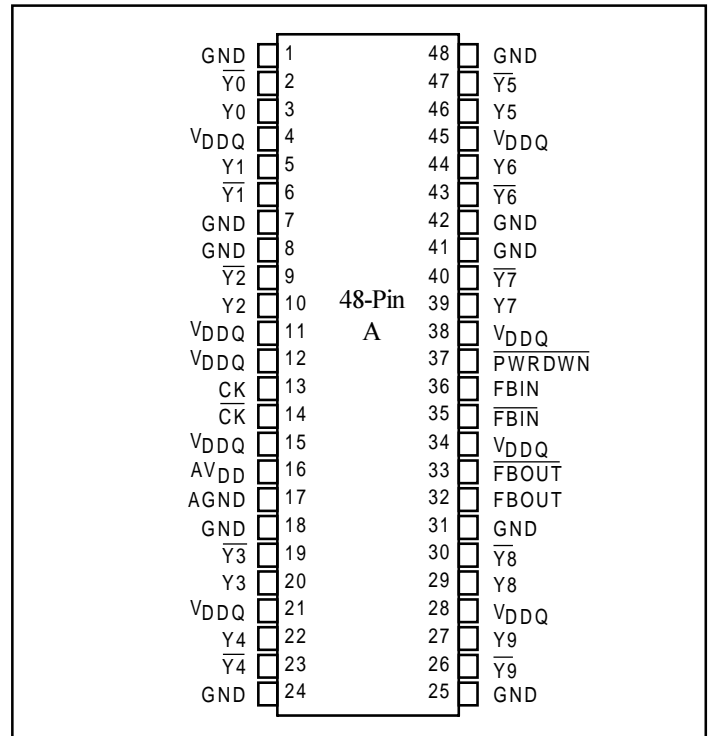
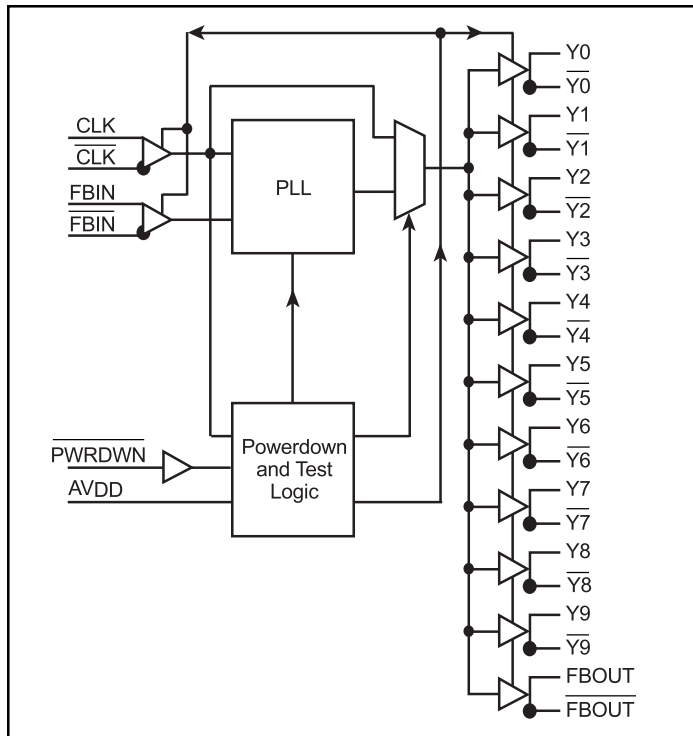

**Pinout Table**

Pin Name	Pin No.	I/O Type	Description
CLK CLK	13 14	I	Reference Clock input
Y <sub>x</sub>	3,5,10,20,22,27,29,39,44,46	O	Clock outputs.
$\overline{Y}_x$	2,6,9,19,23,26,30,40,43,47		Complement Clock outputs.
FBOU $\overline{FBOU}$	32 33		Feedback output, and Complement Feedback Output
FBI $\overline{FBI}$	36 35	I	Feedback output, and Complement Feedback Output
$\overline{PWRDWN}$	37		Power down and output disable for all Y <sub>x</sub> and $\overline{Y}_x$ outputs. When $\overline{PWRDWN} = 0$ , the part is powered down and the differential clock outputs are disabled to a 3-state. When $\overline{PWRDWN} = 1$ , all differential clock outputs are enabled and run at the same frequency as CLK.
V <sub>DDQ</sub>	4,11,12,15,21,28,34,38,45	Power	Power Supply for I/O.
AV <sub>DD</sub>	16		Analog /core power supply. AV <sub>DD</sub> can be used to bypass the PLL for testing purposes. When AV <sub>DD</sub> is strapped to ground, PLL is bypassed and CLK is buffered directly to the device outputs.
AGND	17	Ground	Analog/core ground. Provides the ground reference for the analog/core circuitry
GND	1,7,8,18,24,25,31,41,42,48		Ground

**Function Table**

Inputs				Outputs				PLL State
AV <sub>DD</sub>	G	CLK	$\overline{CLK}$	Y	$\overline{Y}$	FBOU	$\overline{FBOU}$	
GND	H	L	H	L	H	L	H	Bypassed/off
GND	H	H	L	H	L	H	L	Bypassed/off
X	L	L	H	Z	Z	Z	Z	off
X	L	H	L	Z	Z	Z	Z	off
2.5V(nom)	H	L	H	L	H	L	H	on
2.5V(nom)	H	H	L	H	L	H	L	on
2.5V(nom)	X	<20 MHz <sup>(1)</sup>		Z	Z	Z	Z	off

**Notes:** For testing and power saving purposes, PI6CV857 will power down if the frequency of the reference inputs CLK,  $\overline{CLK}$  is well below the operating frequency range. The maximum power down clock frequency is below 20 MHz. For example, PI6CV857 will be powered down when the CLK,  $\overline{CLK}$  stop running.

Z = High impedance

X = Don't care

**Absolute Maximum Ratings** (Over operating free-air temperature range)

Symbol	Parameter	Min.	Max.	Units
$V_{DDQ}, AV_{DD}$	I/O supply voltage range and analog/core supply voltage range	- 0.5	3.6	V
$V_I$	Input voltage range	- 0.5	$V_{DDQ}+0.5$	
$V_O$	Output voltage range	- 0.5		
Tstg	Storage temperature	- 65	150	°C

**Note:** Stress beyond those listed under "Absolute Maximum Ratings" may cause permanent damage to the device.

**Timing Requirements** (Over recommended operating free-air temperature)

Symbol	Description	$AV_{DD}, V_{DDQ} = 2.5V \pm 0.2V$		Units
		Min.	Max.	
$f_{CK}$	Operating clock frequency <sup>(1,2)</sup>	60	170	MHz
	Application clock frequency <sup>(3)</sup>	95	170	
$t_{DC}$	Input clock duty cycle	40	60	%
$t_{STAB}$	PLL stabilization time after powerup		100	ms

**Notes:**

1. The PLL is able to handle spread spectrum induced skew.
2. Operating clock frequency indicates a range over which the PLL is able to lock, but in which the clock is not required to meet the other timing parameters. (Used for low-speed debug).
3. Application clock frequency indicates a range over which the PLL meets all of the timing parameters.

**DC Specifications**  
**Recommended Operating Conditions**

Symbol	Parameter	Min.	Nom.	Max.	Units
$V_{DD}$	Analog/core supply voltage	2.3	2.5	2.7	V
$V_{DDQ}$	Output supply voltage	2.3	2.5	2.7	
$V_{IL}$	Low-level input voltage for $\overline{PWRDWN}$ pin	-0.3		0.7	
$V_{IH}$	High-level input voltage for $\overline{PWRDWN}$ pin	1.7		$V_{DDQ} + 0.3$	
$V_{OH}$	High-level output voltage	2.0		$V_{DDQ}$	
$V_{OL}$	Low-level output voltage	0		0.5	
$V_{IX}$	Input differential-pair crossing voltage	$(V_{DDQ}/2) - 0.2$		$(V_{DDQ}/2) + 0.2$	
$V_{OX}$	Output differential-pair crossing voltage at the DRAM clock input	$(V_{DDQ}/2) - 0.2$		$(V_{DDQ}/2) + 0.2$	
$V_{IN}$	Input voltage level	-0.3		$V_{DDQ} + 0.3$	
$V_{ID}$	Input differential voltage between CK and $\overline{CK}$	0.36		$V_{DDQ} + 0.6$	
$T_A$	Operating free air temperature	0		70	

**Electrical Characteristics**

Parameter		Test Conditions	$V_{DD}, V_{DDQ}$	Min.	Typ.	Max.	Units
$V_{IK}$	All inputs	$I_I = -18\text{mA}$	2.3V			-1.2	V
$I_I$	CK, FBIN	$V_I = V_{DDQ}$ or GND	2.7V			$\pm 10$	$\mu\text{A}$
	$\overline{PWRDWN}$	$V_I = V_{DDQ}$ or GND					
$I_{DDQ}$	Dynamic supply current of $V_{DDQ}$	$V_{DD} = 2.7\text{V}^{(1)}$				300	mA
	Static supply current	CK & $\overline{CK} < 20\text{MHz}$ or $\overline{PWRDWN} = \text{Low}^{(2)}$			100	$\mu\text{A}$	
$I_{ADD}$	Dynamic supply current of $V_{DD}$	$V_{DD} = 2.7\text{V}^{(1)}$			12	mA	
	Static supply current	CK & $\overline{CK} < 20\text{MHz}$ or $\overline{PWRDWN} = \text{Low}^{(2)}$			100	$\mu\text{A}$	
$C_I$	CK and $\overline{CK}$	$V_I = V_{DD}$ or GND	2.5V	2.0		3.0	pF
	FBIN and $\overline{FBIN}$						

**Notes:**

- Driving 9 or 18 DDR SDRAM memory chips with 120-ohm termination resistor for each clock output pair at 134 MHz.
- The maximum power down clock frequency is below 20 MHz.

### AC Specifications

Switching characteristics over recommended operating free-air temperature range (unless otherwise noted)

Parameter	Description	Diagram	AV <sub>CC</sub> , V <sub>DDQ</sub> = 2.5V ±0.2V			Units
			Min.	Nom.	Max	
t <sub>jit(cc)</sub>	Cycle-to-cycle jitter	see Figure 3	-75		75	ps
t(θ)	Static phase offset <sup>(1)</sup>	see Figure 4	-80	0	80	
tsk(o)	Output clock skew	see Figure 5			100	
t <sub>jit(per)</sub>	Period jitter	see Figure 6	-75		75	
t <sub>jit(hper)</sub>	Half-period jitter	see Figure 7	-100		100	
tsl(i)	Input clock slew rate <sup>(2)</sup>	see Figure 8	1.0		2.0	V/ns
tsl(o)	Output clock slew rate <sup>(2)</sup>	see Figure 8	1.0		2.0	
The PLL on the PI6CV857 is capable of meeting all the above parameters while supporting SSC synthesizers with the following parameters <sup>(3)</sup> .						
	SSC modulation frequency		30.00		50.00	kHz
	SSC clock input frequency deviation		0.00		-0.50	%
	PLL loop bandwidth			2		MHz
	Phase angle				-0.031	degrees

**Notes:**

1. Static Phase offset does not include Jitter.
2. The slew rate is determined from the IBIS model and not from the test load.
3. The SSC requirements meet the Intel PC100 SDRAM Registered DIMM specification.

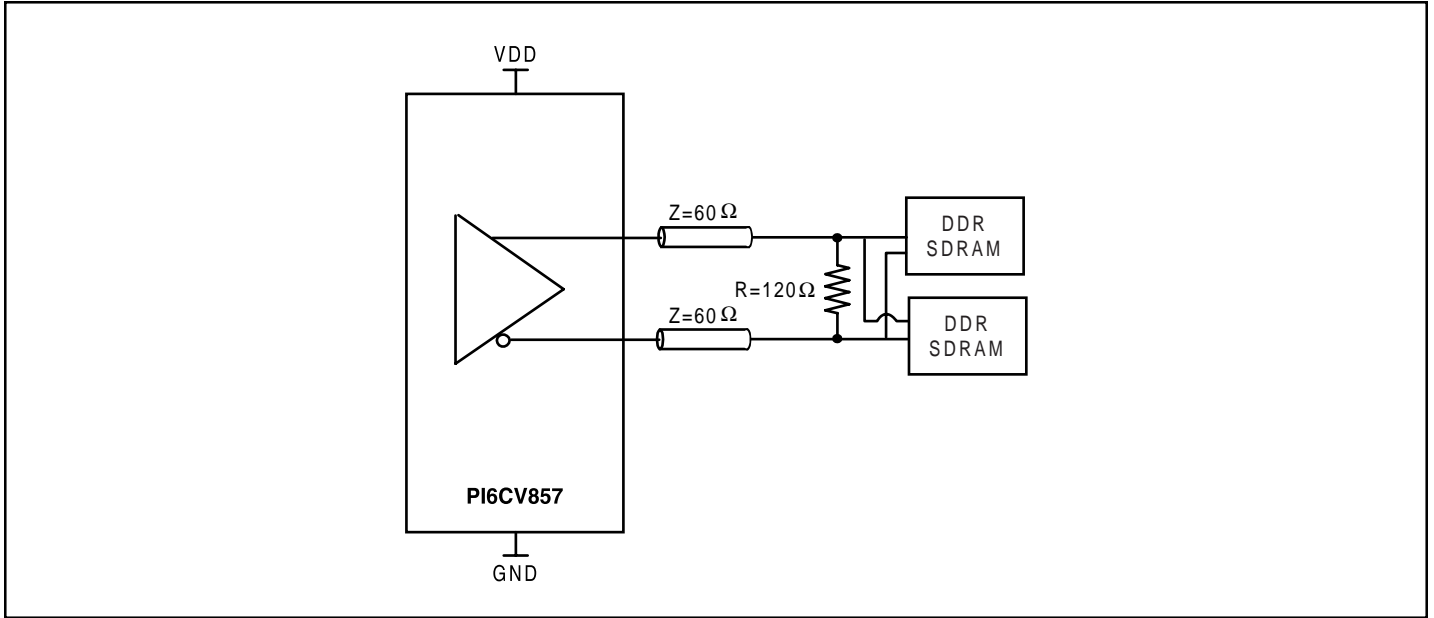
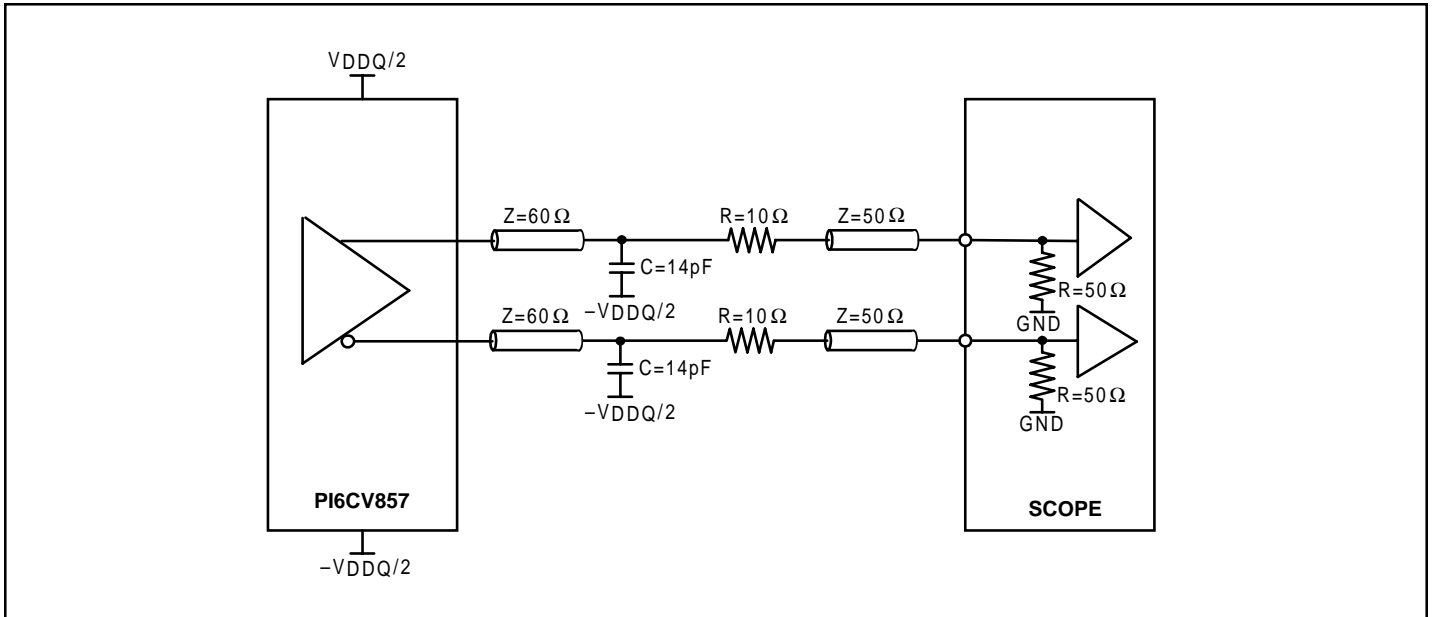
**Figure 1. Output Load**

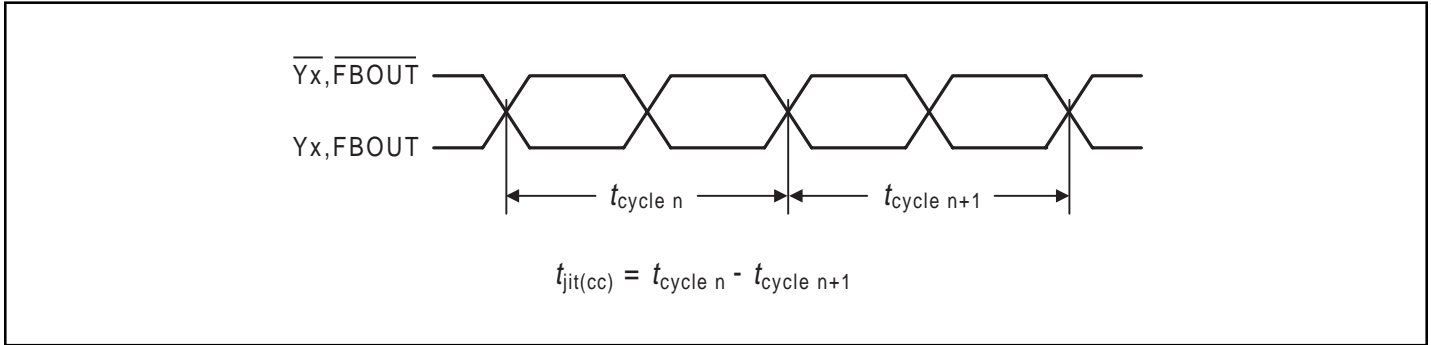
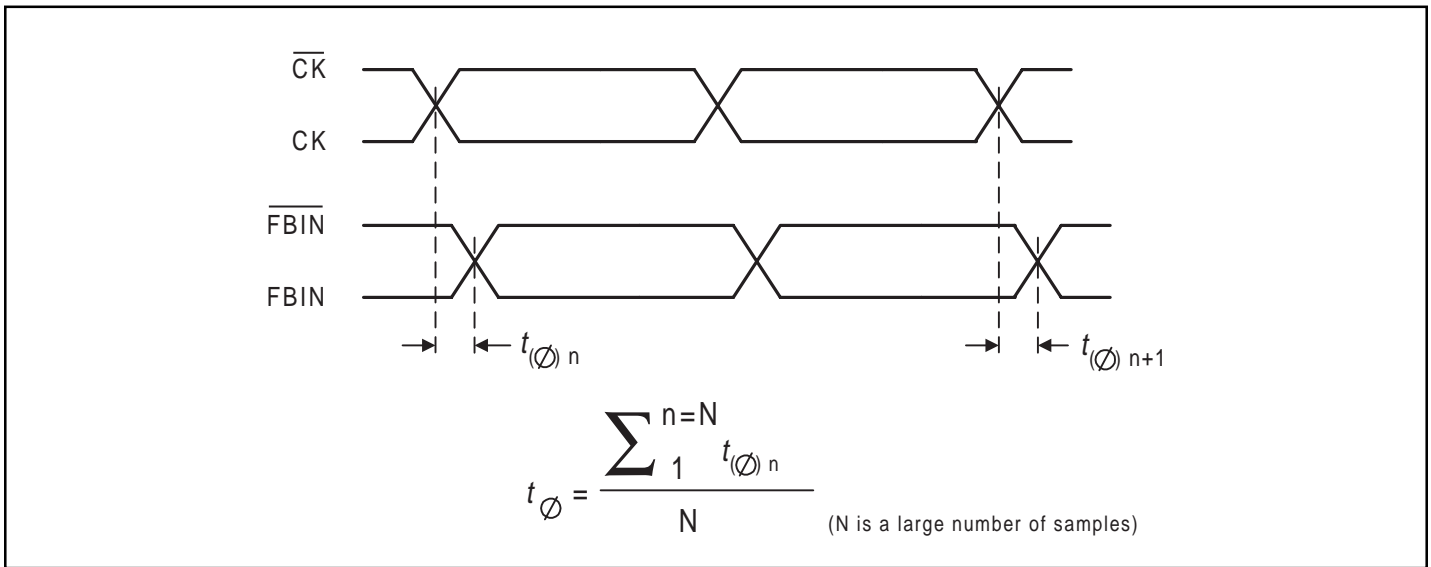
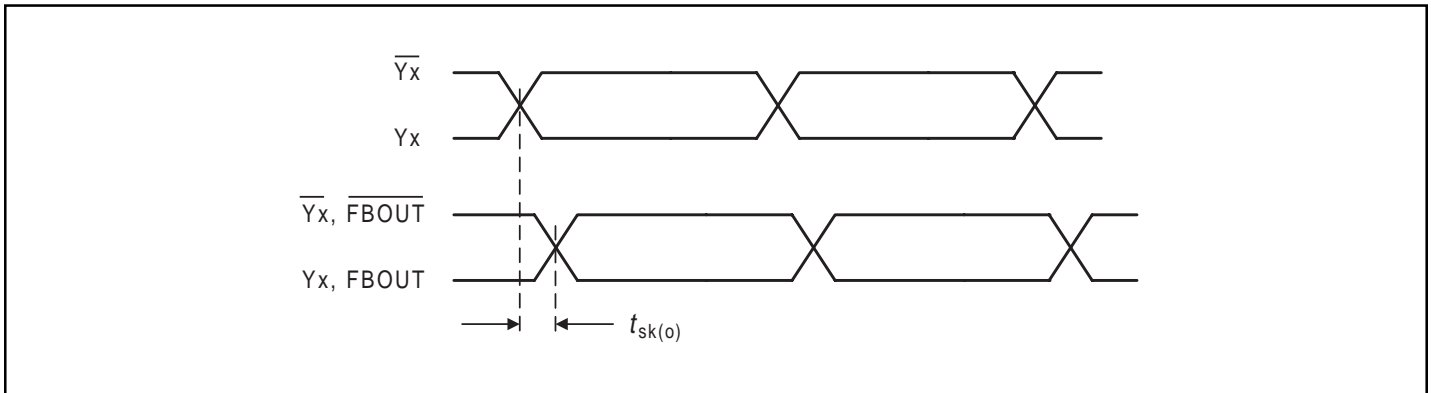
**Figure 2. Output Load Test Circuit**

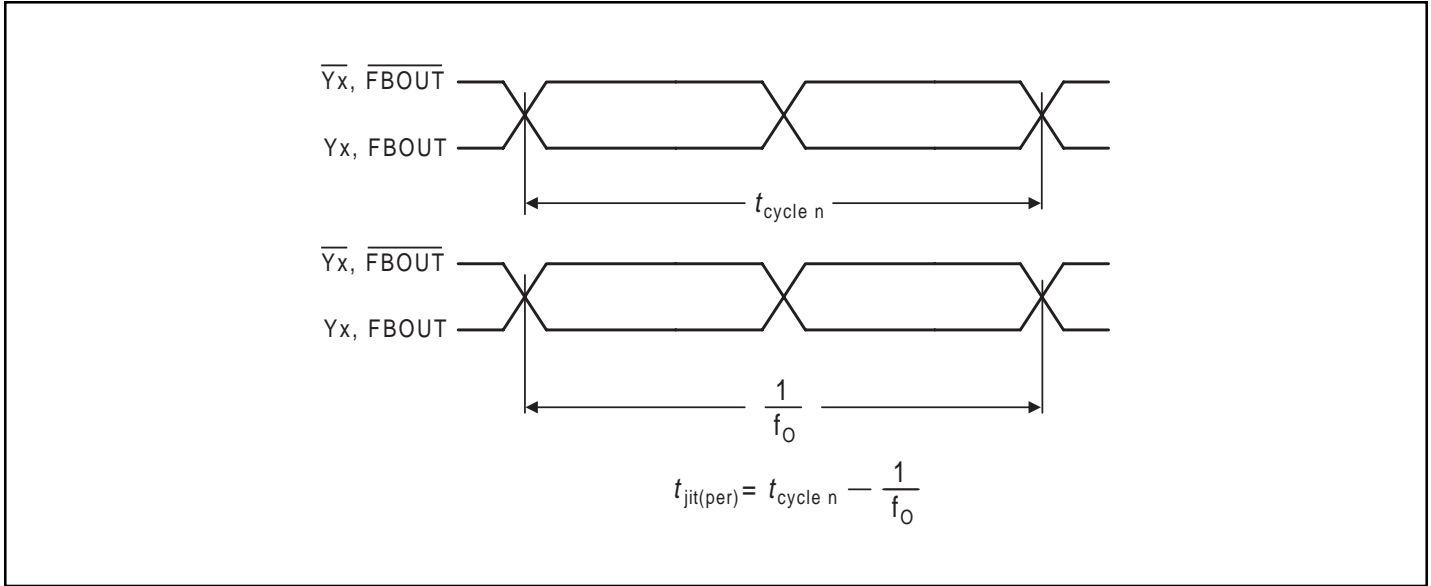
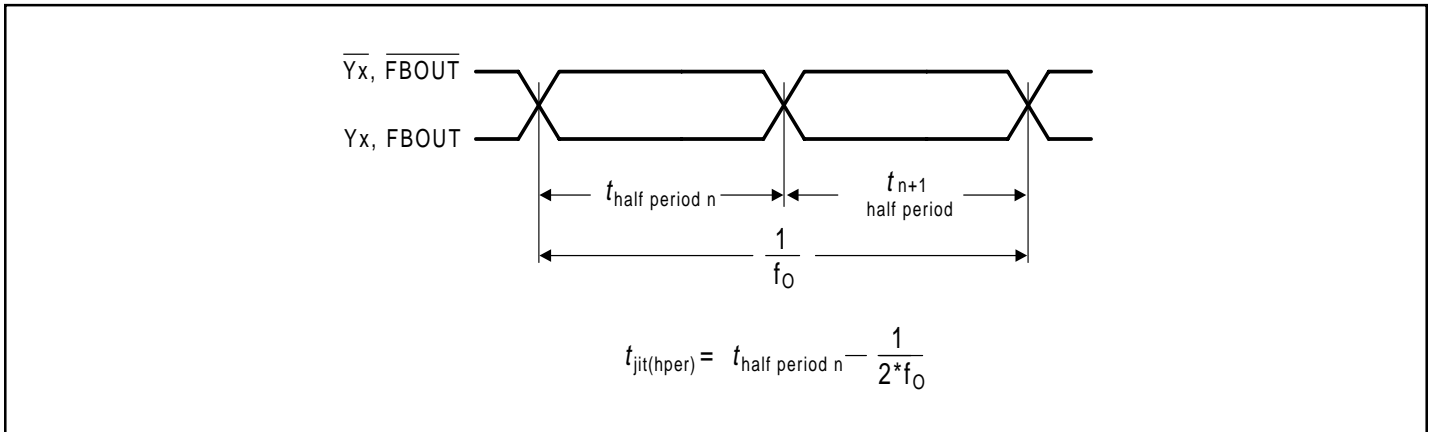
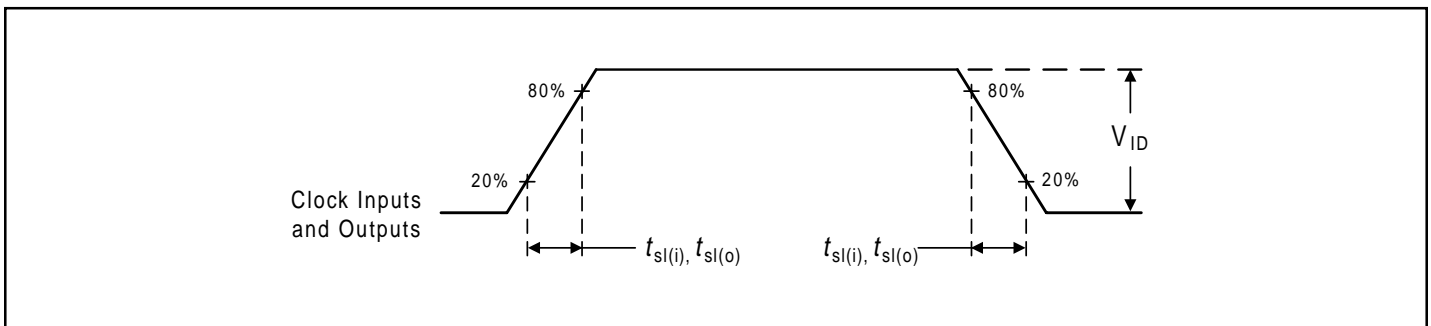
**Figure 3. Cycle-to-Cycle Jitter**

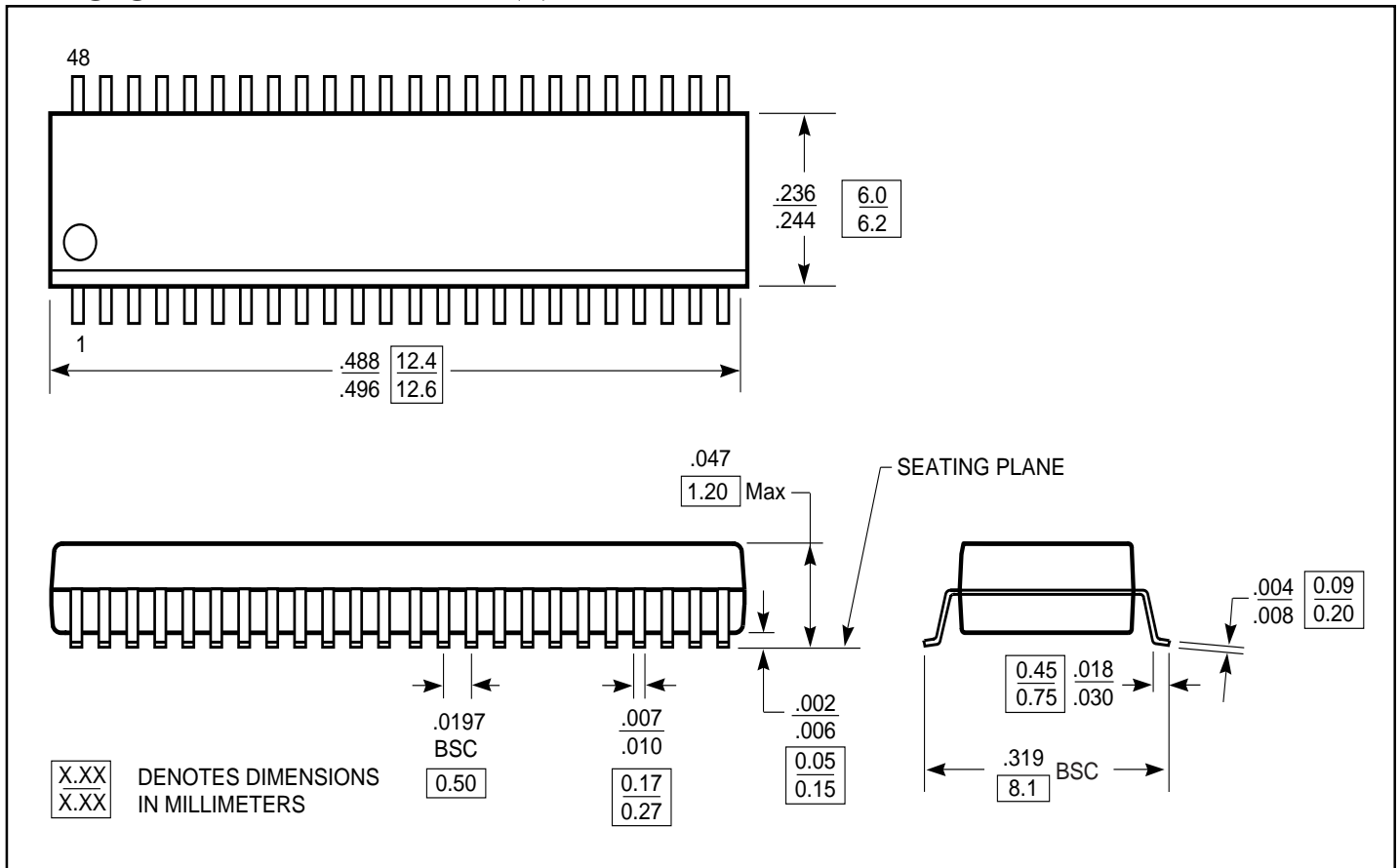
**Figure 4. Static Phase Offset**

**Figure 5. Output Skew**

**Figure 6. Period Jitter**

**Figure 7. Half-Period Jitter**

**Figure 8. Input and Output Slew Rates**

**Packaging Mechanical: 48-Pin TSSOP (A)**

**Ordering Information**

Ordering Code	Package Name	Package Type
PI6CV857A	A48	48-pin, 240-mil wide TSSOP