

## 12-Bit To 24-Bit Registered Bus Exchanger with 3-State Outputs

### Product Features

- PI74ALVCH16270 is designed for low voltage operation
- $V_{CC} = 2.3V$  to  $3.6V$
- Hysteresis on all inputs
- Typical  $V_{OLP}$  (Output Ground Bounce)  $< 0.8V$  at  $V_{CC} = 3.3V, T_A = 25^\circ C$
- Typical  $V_{OHV}$  (Output  $V_{OH}$  Undershoot)  $< 2.0V$  at  $V_{CC} = 3.3V, T_A = 25^\circ C$
- Bus Hold retains last active bus state during 3-STATE, eliminating the need for external pullup resistors
- Industrial operation at  $-40^\circ C$  to  $+85^\circ C$
- Packages available:
  - 56-pin 240 mil wide plastic TSSOP (A)
  - 56-pin 300 mil wide plastic SSOP (V)

### Product Description

Pericom Semiconductor's PI74ALVCH series of logic circuits are produced in the Company's advanced 0.5 micron CMOS technology, achieving industry leading speed.

The PI74ALVCH16270 is used in applications where data must be transferred from a narrow high-speed bus to a wider lower frequency bus.

The device provides synchronous data exchange between the two ports. Data is stored in the internal registers on the low-to-high transition of the clock (CLK) input when the appropriate CLKEN inputs are low. The select (SEL) line selects 1B or 2B data for the A outputs. For data transfer in the A-to-B direction, a two stage pipeline is provided in the A-to-1B path, with a single storage register in the A-to-2B path. Proper control of the CLKENA inputs allows two sequential 12-bit words to be presented synchronously as a 24-bit on the B port. Data flow is controlled by the active-low output enables ( $\overline{OEA}$ ,  $\overline{OEB}$ ). The control terminals are registered to synchronize the bus direction changes with the CLK.

To ensure the high-impedance state during power up or power down,  $\overline{OE}$  should be tied to  $V_{cc}$  through a pullup resistor, the minimum value of the resistor is determined by the current-sinking capability of the driver. Due to  $\overline{OE}$  being routed through a register, the active state of the outputs cannot be determined prior to the arrival of the first clock pulse.

Active bus-hold circuitry is provided to hold unused or floating data inputs at a valid logic level.

### Logic Block Diagram

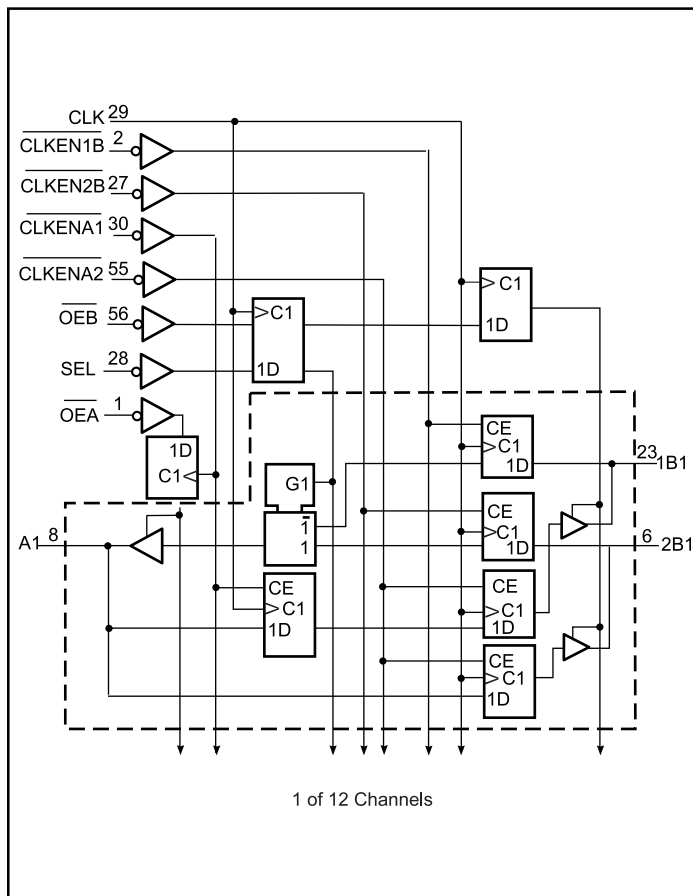

### Product Pin Description

Pin Name	Description
$\overline{OE}$	Output Enable Input (Active LOW)
CLK	Clock
$\overline{SEL}$	Select (Active Low)
$\overline{CLKEN}$	Clock Enable (Active Low)
A,1B,2B	3-State Outputs
GND	Ground
Vcc	Power

### Truth Tables<sup>(1)</sup>

Inputs			Outputs	
CLK	$\overline{OEA}$	$\overline{OEB}$	A	1B, 2B
↑	H	H	Z	Z
↑	H	L	Z	Active
↑	L	H	Active	Z
↑	L	L	Active	Active

### Product Pin Configuration

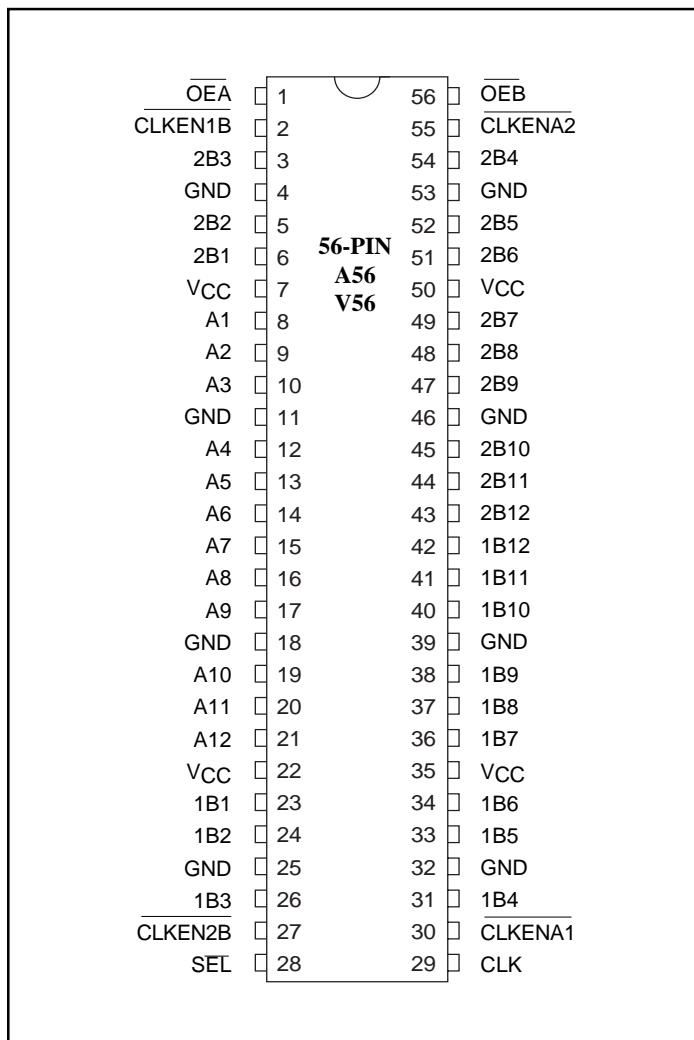

### A to B Storage ( $\overline{OEB} = L$ )

INPUTS				OUTPUTS	
$\overline{CLKENA1}$	$\overline{CLKENA2}$	CLK	A	1B	2B
L	H	↑	L	L <sup>(2)</sup>	2B0 <sup>(3)</sup>
L	H	↑	H	H <sup>(2)</sup>	2B0 <sup>(3)</sup>
L	L	↑	L	L <sup>(2)</sup>	L
L	L	↑	H	H <sup>(2)</sup>	H
H	L	↑	L	1B0 <sup>(3)</sup>	L
H	L	↑	H	1B0 <sup>(3)</sup>	H
H	H	X	X	1B0 <sup>(3)</sup>	2B0 <sup>(3)</sup>

### B to A Storage ( $\overline{OEA} = L$ )

Inputs						Outputs
$\overline{CLKEN1B}$	$\overline{CLKEN2B}$	CLK	SEL	1B	2B	A
H	X	X	H	X	X	A0 <sup>(3)</sup>
X	H	X	L	X	X	A0 <sup>(3)</sup>
L	X	↑	H	L	X	L
L	X	↑	H	H	X	H
X	L	↑	L	X	L	L
X	L	↑	L	X	H	H

#### Notes:

1. H = High Signal Level  
L = Low Signal Level  
X = Irrelevant  
Z = High Impedance  
↑ = Transition, Low to High
2. Two CLK edges are needed to propagate data.
3. Output level before the indicated steady state input conditions were established.

**Maximum Ratings**

(Above which the useful life may be impaired. For user guidelines, not tested.)

Storage Temperature .....	-65°C to +150°C
Ambient Temperature with Power Applied .....	-40°C to +85°C
Input Voltage Range, $V_{IN}$ .....	-0.5V to $V_{CC} + 0.5V$
Output Voltage Range, $V_{OUT}$ .....	-0.5V to $V_{CC} + 0.5V$
DC Input Voltage .....	-0.5V to +5.0V
DC Output Current .....	100 mA
Power Dissipation .....	1.0W

**Note:**

Stresses greater than those listed under MAXIMUM RATINGS may cause permanent damage to the device. This is a stress rating only and functional operation of the device at these or any other conditions above those indicated in the operational sections of this specification is not implied. Exposure to absolute maximum rating conditions for extended periods may affect reliability.

**DC Electrical Characteristics** (Over the Operating Range,  $T_A = -40^\circ\text{C}$  to  $+85^\circ\text{C}$ ,  $V_{CC} = 3.3V \pm 10\%$ )

Parameters	Description	Test Conditions <sup>(1)</sup>	Min.	Typ. <sup>(2)</sup>	Max.	Units
$V_{CC}$	Supply Voltage		2.3		3.6	
$V_{IH}^{(3)}$	Input HIGH Voltage	$V_{CC} = 2.3V$ to $2.7V$	1.7			
		$V_{CC} = 2.7V$ to $3.6V$	2.0			
$V_{IL}^{(3)}$	Input LOW Voltage	$V_{CC} = 2.3V$ to $2.7V$			0.7	
		$V_{CC} = 2.7V$ to $3.6V$			0.8	
$V_{IN}^{(3)}$	Input Voltage		0		$V_{CC}$	
$V_{OUT}^{(3)}$	Output Voltage		0		$V_{CC}$	
$V_{OH}$	Output HIGH Voltage	$I_{OH} = -100\mu\text{A}$ , $V_{CC} = \text{Min. to Max.}$	$V_{CC} - 0.2$			
		$V_{IH} = 1.7V$ , $I_{OH} = -6\text{mA}$ , $V_{CC} = 2.3V$	2.0			
		$V_{IH} = 1.7V$ , $I_{OH} = -12\text{mA}$ , $V_{CC} = 2.3V$	1.7			
		$V_{IH} = 2.0V$ , $I_{OH} = -12\text{mA}$ , $V_{CC} = 2.7V$	2.2			
		$V_{IH} = 2.0V$ , $I_{OH} = -12\text{mA}$ , $V_{CC} = 3.0V$	2.4			
		$V_{IH} = 2.0V$ , $I_{OH} = -24\text{mA}$ , $V_{CC} = 3.0V$	2.0			
$V_{OL}$	Output LOW Voltage	$I_{OL} = 100\mu\text{A}$ , $V_{IL} = \text{Min. to Max.}$			0.2	
		$V_{IL} = 0.7V$ , $I_{OL} = 6\text{mA}$ , $V_{CC} = 2.3V$			0.4	
		$V_{IL} = 0.7V$ , $I_{OL} = 12\text{mA}$ , $V_{CC} = 2.3V$			0.7	
		$V_{IL} = 0.8V$ , $I_{OL} = 12\text{mA}$ , $V_{CC} = 2.7V$			0.4	
		$V_{IL} = 0.8V$ , $I_{OL} = 24\text{mA}$ , $V_{CC} = 3.0V$			0.55	
$I_{OH}^{(3)}$	Output HIGH Current	$V_{CC} = 2.3V$			-12	
		$V_{CC} = 2.7V$			-12	
		$V_{CC} = 3.0V$			-24	
$I_{OL}^{(3)}$	Output LOW Current	$V_{CC} = 2.3V$			12	
		$V_{CC} = 2.7V$			12	
		$V_{CC} = 3.0V$			24	

**DC Electrical Characteristics-Continued** (Over the Operating Range,  $T_A = -40^{\circ}\text{C}$  to  $+85^{\circ}\text{C}$ ,  $V_{CC} = 3.3\text{V} \pm 10\%$ )

Parameters	Description	Test Conditions <sup>(1)</sup>	Min.	Typ. <sup>(2)</sup>	Max.	Units
$I_{IN}$	Input Current	$V_{IN} = V_{CC}$ or GND, $V_{CC} = 3.6\text{V}$			$\pm 5$	$\mu\text{A}$
$I_{IN}$ (HOLD)	Input Hold Current	$V_{IN} = 0.7\text{V}$ , $V_{CC} = 2.3\text{V}$	45			
		$V_{IN} = 1.7\text{V}$ , $V_{CC} = 2.3\text{V}$	-45			
		$V_{IN} = 0.8\text{V}$ , $V_{CC} = 3.0\text{V}$	75			
		$V_{IN} = 2.0\text{V}$ , $V_{CC} = 3.0\text{V}$	-75			
		$V_{IN} = 0$ to $3.6\text{V}$ , $V_{CC} = 3.6\text{V}$			$\pm 500$	
$I_{OZ}$	Output Current (3-STATE Outputs)	$V_{OUT} = V_{CC}$ or GND, $V_{CC} = 3.6\text{V}$			$\pm 10$	
$I_{CC}$	Supply Current	$V_{CC} = 3.6\text{V}$ , $I_{OUT} = 0\mu\text{A}$ , $V_{IN} = \text{GND}$ or $V_{CC}$			40	
$\Delta I_{CC}$	Supply Current per Input @ TTL HIGH	$V_{CC} = 3.0\text{V}$ to $3.6\text{V}$ One Input at $V_{CC} - 0.6\text{V}$ Other Inputs at $V_{CC}$ or GND			750	
$C_I$	Control Inputs	$V_{IN} = V_{CC}$ or GND, $V_{CC} = 3.3\text{V}$		3.5		pF
$C_O$	Outputs	$V_O = V_{CC}$ or GND, $V_{CC} = 3.3\text{V}$		9		

**Notes:**

- For conditions shown as Max. or Min., use appropriate value specified under Electrical Characteristics for the applicable device type.
- Typical values are at  $V_{CC} = 3.3\text{V}$ ,  $+25^{\circ}\text{C}$  ambient and maximum loading.
- Unused Control Inputs must be held HIGH or LOW to prevent them from floating.

**Timing Requirements over Operating Range**

Parameters	Description	$V_{CC} = 2.5\text{V} \pm 0.2\text{V}$		$V_{CC} = 2.7\text{V}$		$V_{CC} = 3.3\text{V} \pm 0.3\text{V}$		Units
		Min.	Max.	Min.	Max.	Min.	Max.	
$f_{\text{CLOCK}}$	Clock frequency	0	150	0	150	0	150	Mhz
$t_w$	Pulse duration, CLK HIGH or Low	3.3		3.3		3.3		ns
$t_{\text{SU}}$	Setup time	A data before $\text{CLK}\uparrow$	4.1		3.8		3.1	
		B data before $\text{CLK}\uparrow$	0.9		1.2		0.9	
		CLKENA1 or CLKENA2 before $\text{CLK}\uparrow$	3.5		3.2		2.7	
		CLKEN1B or CLKEN2B before $\text{CLK}\uparrow$	3.4		3		2.6	
		OE data before $\text{CLK}\uparrow$	4.4		3.9		3.2	
$t_{\text{H}}$	Hold time	A data after $\text{CLK}\uparrow$	0		0		0.2	
		B data after $\text{CLK}\uparrow$	1.4		1		1.7	
		CLKENA1 or CLKENA2 before $\text{CLK}\uparrow$	0		0.1		0.3	
		CLKEN1B or CLKEN2B before $\text{CLK}\uparrow$	0		0		0.6	
		OE after $\text{CLK}\uparrow$	0		0		0.1	
$\Delta t/\Delta V^{(1)}$	Input Transition Rise or Fall	0	10	0	10	0	10	ns/V

**Notes:**

- Unused control inputs must be held HIGH or LOW to prevent them from floating.

**Switching Characteristics over Operating Range<sup>(1)</sup>**

Parameters	From (INPUT)	To (OUTPUT)	V <sub>CC</sub> = 2.5V ± 0.2V		V <sub>CC</sub> = 2.7V		V <sub>CC</sub> = 3.3V ± 0.3V		Units
			Min. <sup>(2)</sup>	Max.	Min. <sup>(2)</sup>	Max.	Min. <sup>(2)</sup>	Max. <sup>(2)</sup>	
F <sub>MAX</sub>			150		150		150		ns
	CLK	B	2	6.5		5.8	1.1	5.1	
	CLK	A	1.7	6		5.4	1	4.7	
t <sub>PD</sub>	$\overline{\text{SEL}}$	A	1.9	6.8		6.4	1	5.5	
t <sub>EN</sub>	CLK	A or B	1.6	7.5		6.8	1	6	
t <sub>DIS</sub>	CLK	A or B	2.6	7.4		6.5	1.1	5.8	

**Notes:**

1. See test circuit and wave forms.
2. Minimum limits are guaranteed but not tested on Propagation Delays.

**Operating Characteristics, T<sub>A</sub> = 25°C**

Parameter		Test Conditions	V <sub>CC</sub> = 2.5V ± 0.2V	V <sub>CC</sub> = 3.3V ± 0.3V	Units
			Typical		
C <sub>PD</sub> Power Dissipation Capacitance	Outputs Enabled	C <sub>L</sub> = 50pF, f = 10 MHz	87	120	pF
	Outputs Disabled		80.5	118	