

**Fast CMOS 3.3V 16-Bit
Transparent Latch**
Product Features

- Functionally compatible with FCT3, LVT, and 74 series 16373 families of products
- Tri-State outputs
- 5V Tolerant inputs and outputs
- 2.0V-3.6V Vcc operation
- Balanced sink and source output drives (24 mA)
- Low ground bounce outputs
- Supports live insertion
- ESD Protection exceeds 2000V, Human Body Model
200V, Machine Model
- Packages available:
 - 48-pin 240-mil wide plastic TSSOP (A)
 - 48-pin 300-mil wide plastic SSOP (V)

Product Description

Pericom Semiconductor's PI74LCX series of logic circuits are produced in the Company's advanced 0.6 micron CMOS technology, achieving industry leading speed grades.

The PI74LCX16373 is a 16-bit transparent latch designed with 3-state outputs and are intended for bus oriented applications. The Output Enable and Latch Enable controls are organized to operate as two 8-bit latches or one 16-bit latch. When Latch Enable (LE) is HIGH, the flip-flops appear transparent to the data. The data that meets the set-up time when LE is LOW is latched. When \overline{OE} is HIGH, the bus output is in the high impedance state.

The PI74LCX16373 can be driven from either 3.3V or 5.0V devices allowing this device to be used as a translator in a mixed 3.3/5.0V system.

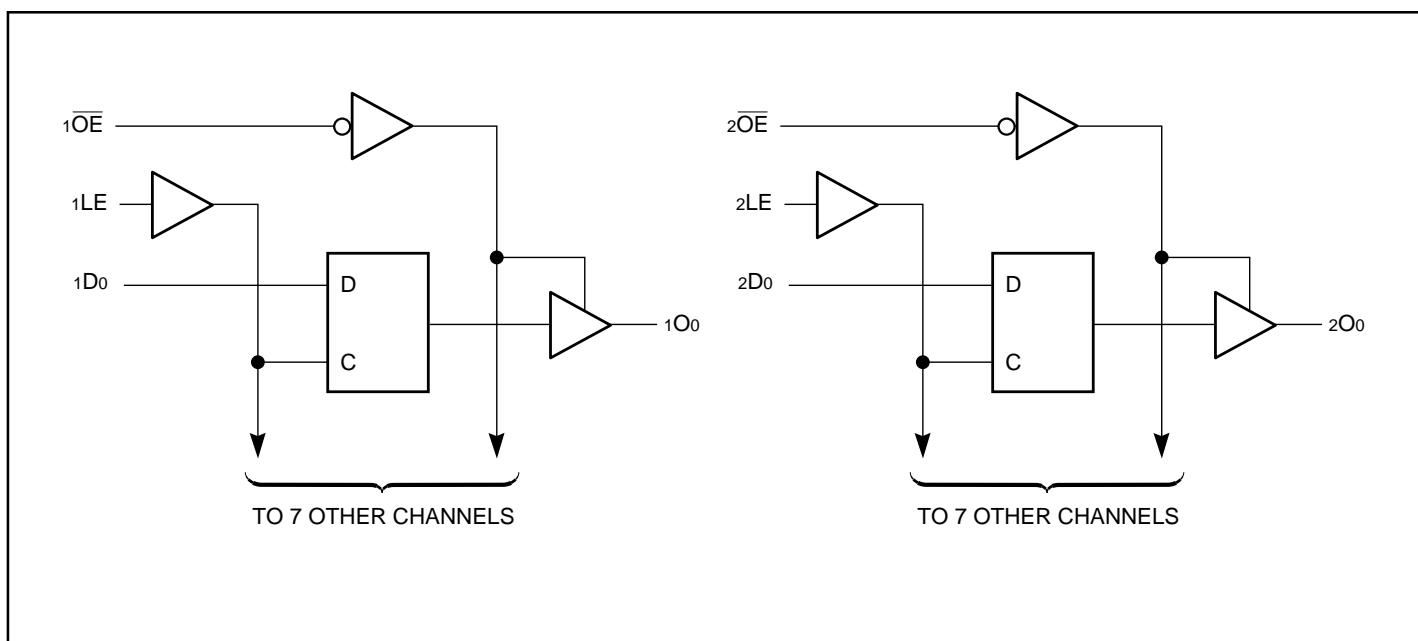
Logic Block Diagram

Product Pin Description

Pin Name	Description
\overline{xOE}	3-State Output Enable Inputs (Active LOW)
xLE	Latch Enable Inputs (Active HIGH)
xDx	Data Inputs
xOx	3-State Outputs
GND	Ground
Vcc	Power

Truth Table⁽¹⁾

Inputs ⁽¹⁾			Outputs ⁽¹⁾
\overline{xOE}	xLE	xDx	xOx
L	H	H	H
L	H	L	L
H	X	X	Z
L	L	X	O ₀

Note:

1. H = High Voltage Level, X = Don't Care,
L = Low Voltage Level, Z = High Impedance
O₀ = Previous O₀ before HIGH-to-LOW transition
of Latch Enable

Product Pin Configuration

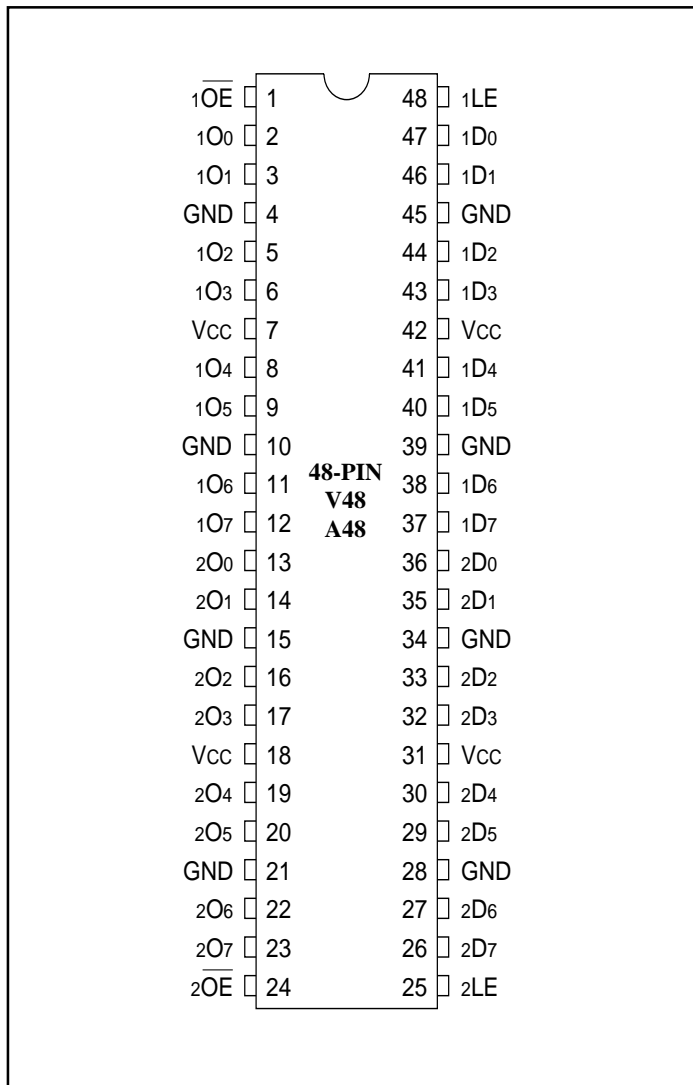

Maximum Ratings

(Above which the useful life may be impaired. For user guidelines, not tested.)

Storage Temperature	-65°C to +150°C
Ambient Temperature with Power Applied	-40°C to +85°C
Supply Voltage to Ground Potential (Inputs & V _{CC} Only)	-0.5V to +7.0V
Supply Voltage to Ground Potential (Outputs & D/O Only) ...	-0.5V to +7.0V
DC Input Voltage	-0.5V to +7.0V
DC Output Current	120 mA
Power Dissipation	1.0W

Note:

Stresses greater than those listed under MAXIMUM RATINGS may cause permanent damage to the device. This is a stress rating only and functional operation of the device at these or any other conditions above those indicated in the operational sections of this specification is not implied. Exposure to absolute maximum rating conditions for extended periods may affect reliability.

Recommended Operating Conditions

Symbol	Parameter	Min.	Max.	Units		
V _{CC}	Supply Voltage	Operating	2.0	3.6	V	
		Data Retention	1.5	3.6		
V _I	Input Voltage	0	5.5	V		
V _O	Output Voltage	HIGH or LOW State	0	V _{CC}	V	
		TRI-State	0	5.5		
I _{OH} /I _{OL}	Output Current	V _{CC} = 3.0V-3.6V	—	±24	mA	
		V _{CC} = 2.7V	—	±12		
T _A	Free-Air Operating Temperature	-40	+85	°C		
Δt/ΔV	Input Edge Rate	V = 0.8V-2.0V, V _{CC} = 3.0V		0	10	ns/V

DC Electrical Characteristics (Over the Operating Range, $T_A = -40^{\circ}\text{C}$ to $+85^{\circ}\text{C}$, $V_{CC} = 2.7\text{V}$ to 3.6V)

Parameters	Description	Test Conditions ⁽¹⁾		Min.	Typ ⁽²⁾	Max.	Units
V_{IH}	Input HIGH Voltage	Guaranteed Logic HIGH Level		2.0	—	—	V
V_{IL}	Input LOW Voltage	Guaranteed Logic LOW Level		—	—	0.8	
V_{OH}	Output HIGH Voltage	$V_{CC} = 2.7-3.6$	$I_{OH} = -0.1\text{mA}$	$V_{CC}-0.2$	—	—	
		$V_{CC} = 2.7$	$I_{OH} = -1\text{ mA}$	2.2	—	—	
		$V_{CC} = 3.0$	$I_{OH} = -1\text{ mA}$	2.4	—	—	
			$I_{OH} = -2\text{ mA}$	2.2	—	—	
V_{OL}	Output LOW Voltage	$V_{CC} = 2.7-3.6$	$I_{OL} = 0.1\text{mA}$	—	—	0.2	
		$V_{CC} = 2.7$	$I_{OL} = 12\text{mA}$	—	—	0.4	
		$V_{CC} = 3.0$	$I_{OL} = 16\text{mA}$	—	—	0.4	
			$I_{OL} = 24\text{mA}$	—	—	0.55	
V_{IK}	Clamp Diode Voltage	$V_{CC} = \text{Min.}, I_{IN} = -18\text{ mA}$		—	-0.7	-1.2	
I_I	Input Leakage Current	$0 \leq V_I \leq 5.5\text{V}$	$V_{CC} = 2.7-3.6$	—	—	± 5	μA
I_{OZ}	Tri-State Output Leakage	$0 \leq V_O \leq 5.5\text{V}$ $V_I = V_{IH}$ or V_{IL}	$V_{CC} = 2.7-3.6$	—	—	± 5	
I_{OFF}	Power Down Disable	$V_{CC} = 0\text{V}, V_{IN}$ or $V_{OUT} \leq 5.5\text{V}$		—	—	± 10	
I_{CC}	Quiescent Power Supply Current	$V_{CC} = \text{Max.}$	$V_{IN} = \text{GND}$ or V_{CC}	—	0.1	10	
ΔI_{CC}	Quiescent Power Supply Current TTL Inputs HIGH	$V_{CC} = \text{Max.}$	$V_{IN} = V_{CC} - 0.6\text{V}^{(3)}$	—	—	500	

Notes:

1. For Max. or Min. conditions, use appropriate value specified under Electrical Characteristics for the applicable device type.
2. Typical values are at $V_{CC} = 3.3\text{V}$, $+25^{\circ}\text{C}$ ambient.
3. Per TTL driven input; all other inputs at V_{CC} or GND.

Capacitance

Parameters	Description	Test Conditions	Typ.	Units
C_{IN}	Input Capacitance	$V_{CC} = \text{Open}, V_I = 0\text{V}$ or V_{CC}	7	pF
C_{OUT}	Output Capacitance	$V_{CC} = 3.3\text{V}, V_I = 0\text{V}$ or V_{CC}	8	
C_{PD}	Power Dissipation Capacitance	$V_{CC} = 3.3\text{V}, V_I = 0\text{V}$ or $V_{CC}, F = 10\text{ MHz}$	20	

Switching Characteristics over Operating Range

Parameters	Description	Conditions	V _{CC} = 3.3V ± 0.3V		V _{CC} = 2.7V		Units
			Min.	Max.	Min.	Max.	
t _{PHL} t _{PLH}	Propagation Delay Dn to On	C _L = 50pF R _L = 500Ω	1.5	5.4	1.5	5.9	ns
t _{PHL} t _{PLH}	Propagation Delay LE to On		1.5	5.5	1.5	6.4	
t _{PZL} t _{PZH}	Output Enable Time		1.5	6.1	1.5	6.5	
t _{PLZ} t _{PHZ}	Output Disable Time		1.5	6.0	1.5	6.3	
t _S	Setup Time, Dn to LE		2.5	—	2.5	—	
t _H	Hold Time, Dn to LE		1.5	—	1.5	—	
t _W	LE Pulse Width		3.0	—	3.0	—	
t _{SK(O)}	Output to Output Skew ⁽¹⁾		—	1.0	—	—	

Note:

1. Skew between any two outputs, of the same package, switching in the same direction.

Dynamic Switching Characteristics (T_A = +25°C)

Parameters	Description	Test Conditions ⁽¹⁾	Typ.	Units
V _{OLP}	Dynamic LOW Peak Voltage	V _{CC} = 3.3V, C _L = 50pF V _{IH} = 3.3V, V _{IL} = 0V	0.8	V
V _{OLV}	Dynamic LOW Valley Voltage	V _{CC} = 3.3V, C _L = 50pF V _{IH} = 3.3V, V _{IL} = 0V	0.8	

Note:

1. Measured with n–1 outputs switching from High-to-Low or Low-to-High. The remaining output is measured in the LOW state.