

## 3.3V 8-Bit Bi-Directional Transceiver with 3-State Outputs

### Product Features

- Advanced low power CMOS design for 2.7V to 3.6V  $V_{CC}$  operation
- Supports 5V input/output tolerance in mixed signal mode operation
- Function compatible with LVT family of products
- Balanced  $\pm 24\text{mA}$  output drive
- Typical  $V_{OLP}$  (Output Ground Bounce)  $< 0.8\text{V}$  at  $V_{CC}=3.3\text{V}$ ,  $T_A=25^\circ\text{C}$
- $I_{off}$  and Power Up/Down 3-State support live insertion
- Latch-up performance exceeds 200mA Per JESD78
- ESD protection exceeds JESD 22
  - 2000V Human-Body Model (A114-B)
  - 200V Machine Model (A115-A)
- Packages (Pb-free available):
  - 20-pin 209-mil wide plastic SSOP (H)
  - 20-pin 173-mil wide plastic TSSOP (L)
  - 20-pin 300-mil wide plastic SOIC (S)

### Product Description

Pericom Semiconductor's PI74LVTC series of logic circuits are produced using the Company's advanced CMOS technology, achieving industry leading speed.

The PI74LVTC245 is a non-inverting 8-bit Bidirectional Transceiver designed for low-voltage 2.7V to 3.6V  $V_{CC}$  operation, with the capability of interfacing to the 5V system environment. This transceiver is designed for asynchronous two-way communication between data buses. The direction control input pin (DIR) determines the direction of the dataflow from the A bus to the B bus or from the B bus to the A bus. The output enable ( $\overline{OE}$ ) input, when HIGH, disables both A and B ports by placing them in HIGH Z condition.

When  $V_{cc}$  is between 0 to 1.5V during power up or power down, the outputs of the device are in the high-impedance state. To ensure the high-impedance state above 1.5V,  $\overline{OE}$  should be tied to  $V_{CC}$  through a pullup resistor; the minimum value of the resistor is determined by the current sinking capability of the driver.

The device fully supports live-insertion with its  $I_{off}$  and power-up/down 3-state. The  $I_{off}$  circuitry disables the outputs when the power is off, preventing the backflow of damaging current through the device. Power-up/down 3-state places the outputs in the high-impedance state during power up or power down, preventing driver conflict.

### Logic Block Diagram

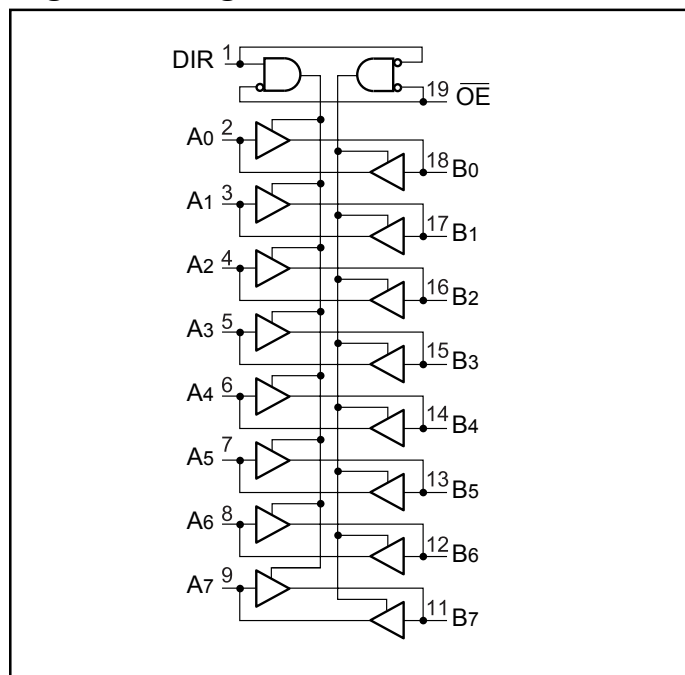

### Product Pin Configuration

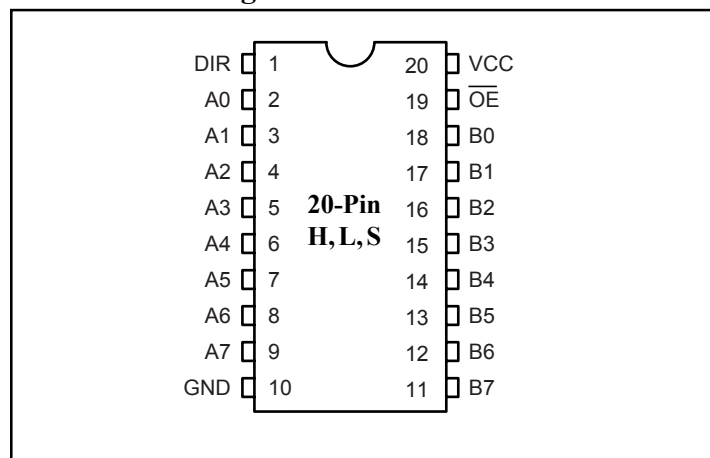



**Recommended Operating Conditions<sup>(5)</sup>**

|                     |                                    | Min.                           | Max. | Units           |      |
|---------------------|------------------------------------|--------------------------------|------|-----------------|------|
| V <sub>CC</sub>     | Supply Voltage                     | Operating                      | 2.7  | 3.6             | V    |
| V <sub>IH</sub>     | High-level Input Voltage           | V <sub>CC</sub> = 2.7V to 3.6V | 2.0  |                 |      |
| V <sub>IL</sub>     | Low-level Input Voltage            | V <sub>CC</sub> = 2.7V to 3.6V |      | 0.8             |      |
| V <sub>I</sub>      | Input Voltage                      | 0                              | 5.5  |                 |      |
| V <sub>O</sub>      | Output Voltage                     | High or Low State              | 0    | V <sub>CC</sub> |      |
|                     |                                    | 3-State                        | 0    | 5.5             |      |
| I <sub>OH</sub>     | High-level output current          | V <sub>CC</sub> = 2.7V         |      | - 12            | mA   |
|                     |                                    | V <sub>CC</sub> = 3.0V to 3.6V |      | - 24            |      |
| I <sub>OL</sub>     | Low-level output current           | V <sub>CC</sub> = 2.7V         |      | 12              |      |
|                     |                                    | V <sub>CC</sub> = 3.0V to 3.6V |      | 24              |      |
| Δt/ΔV               | Input transition rise or fall rate |                                |      | 6               | ns/V |
| Δt/ΔV <sub>CC</sub> | Power-up ramp rate                 |                                | 150  |                 | μs/V |
| T <sub>A</sub>      | Operating free-air temperature     |                                | - 40 | 85              | °C   |

**Notes:**

5. All unused inputs must be held at V<sub>CC</sub> or GND to ensure proper device operation.

**DC Electrical Characteristics** (Over the Operating Range,  $T_A = -40^{\circ}\text{C}$  to  $+85^{\circ}\text{C}$ )

| Parameters         | Description                      |  | Test Conditions  |                                   | Min.                   | Max.    | Units |
|--------------------|----------------------------------|--|--|-----------------------------------|------------------------|---------|-------|
| $V_{IK}$           | Clamp Diode Voltage              |  | $V_{CC} = 2.7\text{V}$   | $I_I = -18\text{mA}$              |                        | -1.2V   | V     |
| $V_{OH}$           | Output High Voltage              |  | $V_{CC} = 2.7\text{V to } 3.6\text{V}$   | $I_{OH} = -100\mu\text{A}$        | $V_{CC} - 0.2\text{V}$ |         |       |
|                    |                                  |  | $V_{CC} = 2.7\text{V}$   | $I_{OH} = -12\text{mA}$           | 2.2                    |         |       |
|                    |                                  |  | $V_{CC} = 3\text{V}$   | $I_{OH} = -12\text{mA}$           | 2.4                    |         |       |
|                    |                                  |  |  | $I_{OH} = -24\text{mA}$           | 2.2                    |         |       |
| $V_{OL}$           | Output Low Voltage               |  | $V_{CC} = 2.7\text{V to } 3.6\text{V}$   | $I_{OL} = 100\mu\text{A}$         |                        | 0.2     |       |
|                    |                                  |  | $V_{CC} = 2.7\text{V}$   | $I_{OL} = 12\text{mA}$            |                        | 0.4     |       |
|                    |                                  |  | $V_{CC} = 3\text{V}$   | $I_{OL} = 12\text{mA}$            |                        | 0.4     |       |
|                    |                                  |  |  | $I_{OL} = 24\text{mA}$            |                        | 0.55    |       |
| $I_I$              | Input Leakage Current            | Control Inputs                         | $V_{CC} = 0\text{V to } 3.6\text{V}$   | $V_I = 0\text{V to } 5.5\text{V}$ |                        | $\pm 5$ |       |
|                    |                                  | A or B Ports <sup>(6)</sup>            | $V_{CC} = 3.6\text{V}$   | $V_I = 5.5\text{V}$               |                        | $\pm 5$ |       |
|                    |                                  |  |  | $V_I = V_{CC}$                    |                        |         |       |
| $V_I = \text{GND}$ |                                  |  |  |                                   |                        |         |       |
| $I_{OFF}$          | Power Off Output Leakage Current | $V_{CC} = 0\text{V}$                   | $V_I$ or $V_O = 0\text{V to } 5.5\text{V}$                                     |                                   |                        | $\pm 5$ |       |
| $I_{OZPU}$         | Power-Up 3-State Current         | $V_{CC} = 0\text{V to } 1.5\text{V}$   | $V_O = 0.5\text{V to } 5.5\text{V}$ ,<br>$\overline{OE} = \text{don't care}$   |                                   |                        | $\pm 5$ |       |
| $I_{OZPD}$         | Power-Down 3-State Current       | $V_{CC} = 1.5\text{V to } 0\text{V}$   | $V_O = 0.5\text{V to } 5.5\text{V}$ ,<br>$\overline{OE} = \text{don't care}$   |                                   |                        | $\pm 5$ |       |
| $I_{CC}$           | Quiescent Power Supply Current   | $V_{CC} = 2.7\text{V to } 3.6\text{V}$ | $V_I = V_{CC}$ or GND<br>$3.6\text{V} \leq V_I \leq 5.5\text{V}^{(7)}$         | $I_O = 0$                         |                        | 100     |       |
| $\Delta I_{CC}$    | Increase in $I_{CC}$             | $V_{CC} = 3.0\text{V to } 3.6\text{V}$ | One input at $V_{CC} - 0.6\text{V}^{(8)}$ ,<br>Other inputs at $V_{CC}$ or GND |                                   |                        | 500     |       |

**Notes:**

6. For I/O ports, Input Leakage Current ( $I_I$ ) includes the 3-state Output Leakage Current. Unused pins are at  $V_{CC}$  or GND.
7. This applies in the disabled state only.
8. This is the increase in supply current for each input that is at the specified TTL voltage level rather than  $V_{CC}$  or GND.

### Capacitance

| Parameters      | Description                                   | Test Conditions  | Typ. <sup>(9)</sup> | Units |
|-----------------|---|--|---------------------|-------|
| C <sub>IN</sub> | Control Input Capacitance                     | V <sub>CC</sub> = 3.3V, V <sub>I</sub> = V <sub>CC</sub> or GND          | 3.3                 | pF    |
| C <sub>IO</sub> | Input/Output Capacitance                      | V <sub>CC</sub> = 3.3V, V <sub>O</sub> = V <sub>CC</sub> or GND          | 7.8                 |       |
| C <sub>PD</sub> | Power Dissipation Capacitance <sup>(10)</sup> | V <sub>CC</sub> = 3.3V, V <sub>I</sub> = 0 or V <sub>CC</sub> , f=10 MHz | 33                  |       |

**Notes:**

9. All typical values are measured at V<sub>CC</sub> = 3.3V, T<sub>A</sub> = 25°C.

10. C<sub>PD</sub> is defined as the value of the internal equivalent capacitance which is derived from dynamic operating current consumption (I<sub>CCD</sub>) at no output loading and operating at 50% duty cycle, C<sub>PD</sub> is related to I<sub>CCD</sub> dynamic operating current by the expression: I<sub>CCD</sub> = (C<sub>PD</sub>)(V<sub>CC</sub>)(f<sub>IN</sub>)+(I<sub>CCstatic</sub>).

### Switching Characteristics Over Operating Range

| Parameters         | Description                           | From (Input)    | To (Output) | V <sub>CC</sub> = 3.3V ±0.3V                   |      | V <sub>CC</sub> = 2.7V                         |      | Units |
|--------------------|---------------------------------------|-----------------|-------------|--|------|--|------|-------|
|                    |                                       |                 |             | C <sub>L</sub> = 50pF, R <sub>L</sub> = 500Ohm |      | C <sub>L</sub> = 50pF, R <sub>L</sub> = 500Ohm |      |       |
|                    |                                       |                 |             | Min  | Max. | Min.   | Max. |       |
| t <sub>PLH</sub>   | Propagation Delay                     | A or B          | B or A      | 1.0  | 5.4  | 1.0  | 5.8  | ns    |
| t <sub>PHL</sub>   |                                       |                 |             | 1.0  | 5.4  | 1.0  | 5.8  |       |
| t <sub>PZH</sub>   | Output Enable Time                    | $\overline{OE}$ | A or B      | 1.0  | 7.0  | 1.0  | 7.9  |       |
| t <sub>PZL</sub>   |                                       |                 |             | 1.0  | 7.0  | 1.0  | 7.9  |       |
| t <sub>PHZ</sub>   | Output Disable Time                   | $\overline{OE}$ | A or B      | 1.0  | 5.4  | 1.0  | 5.8  |       |
| t <sub>PLZ</sub>   |                                       |                 |             | 1.0  | 5.4  | 1.0  | 5.8  |       |
| t <sub>SK(O)</sub> | Output to Output Skew <sup>(11)</sup> |                 |             |  | 0.5  |  |      |       |

**Notes:**

11. Skew between any two outputs, switching in the same direction.

**PARAMETER MEASUREMENT INFORMATION**

$V_{CC} = 2.7V$  and  $3.3V \pm 0.3V$

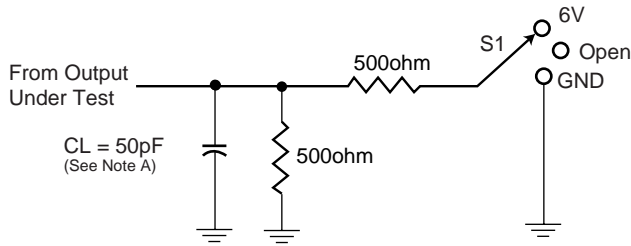

| Test              | S1   |
|-------------------|------|
| $t_{PLH}/t_{PHL}$ | Open |
| $t_{PLZ}/t_{PZL}$ | 6V   |
| $t_{PHZ}/t_{PZH}$ | GND  |

**Load Circuit**

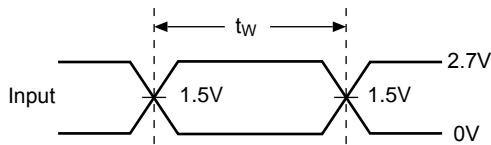

**Voltage Waveforms  
Pulse Duration**

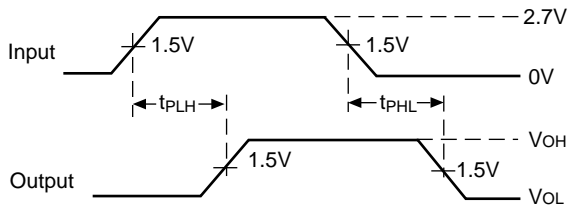

**Voltage Waveforms  
Propagation Delay Times**

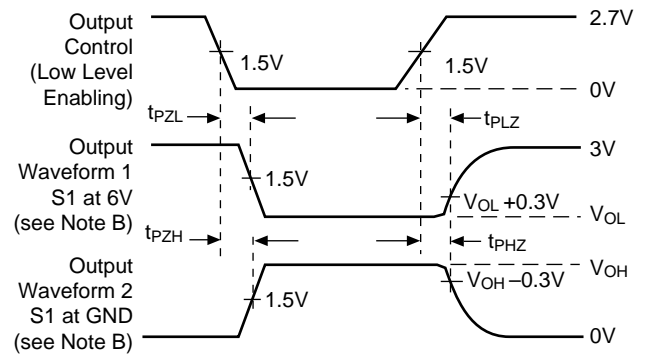

**Voltage Waveforms  
Enable and Disable Times**

**Figure 1. Load Circuit and Voltage Waveforms**

**Notes:**

- A.  $C_L$  includes probe and jig capacitance.
- B. Waveform 1 is for an output with internal conditions such that the output is low except when disabled by the output control. Waveform 2 is for an output with internal conditions such that the output is high except when disabled by the output control.
- C. All input impulses are supplied by generators having the following characteristics:  $PRR \leq 10$  MHz,  $Z_O = 50\text{ohm}$ ,  $t_R \leq 2.5\text{ns}$ ,  $t_F \leq 2.5\text{ns}$ .
- D. The outputs are measured one at a time with one transition per measurement.

**Packaging Mechanical: 20-pin SSOP (H)**

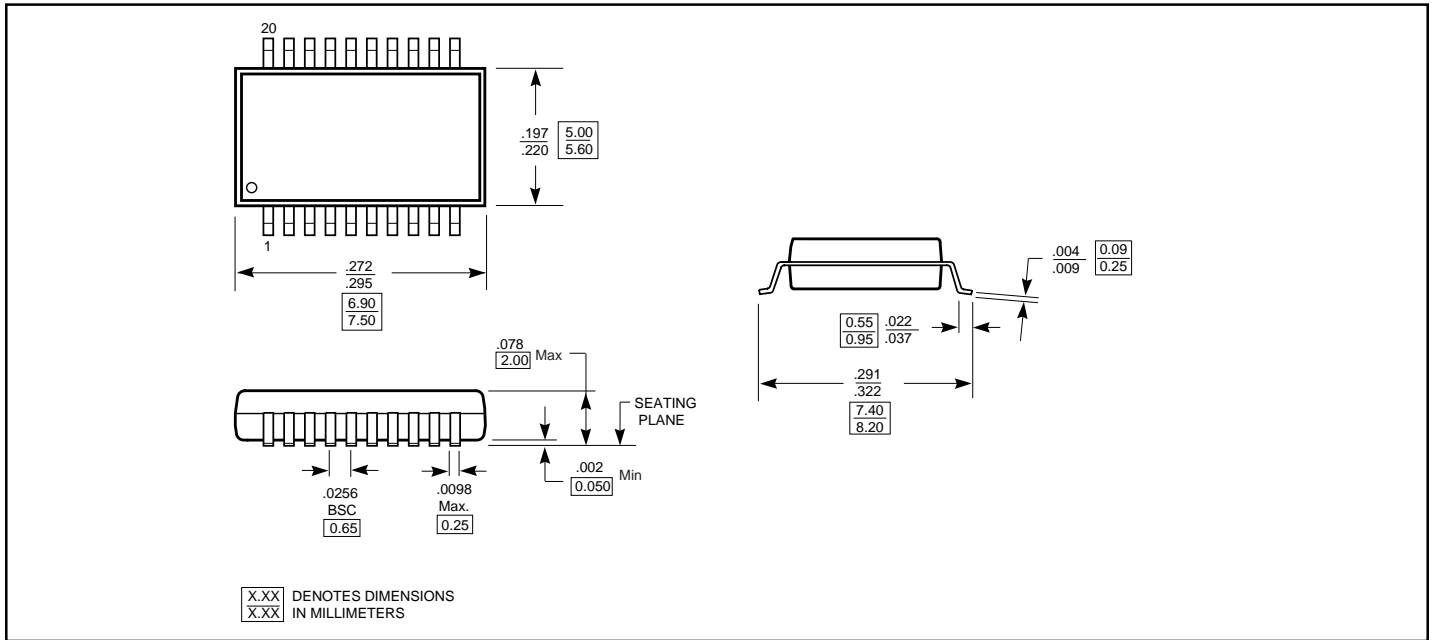

**Packaging Mechanical: 20-pin TSSOP (L)**

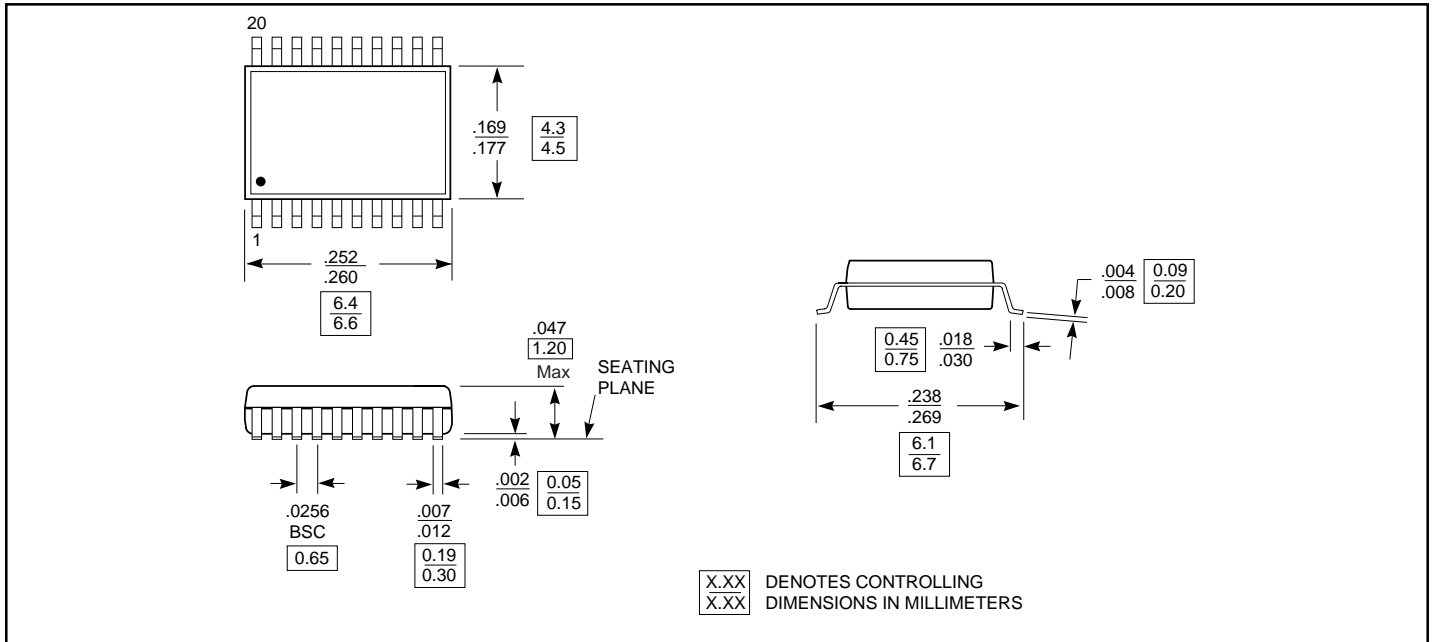

**Packaging Mechanical: 20-pin SOIC (S)**

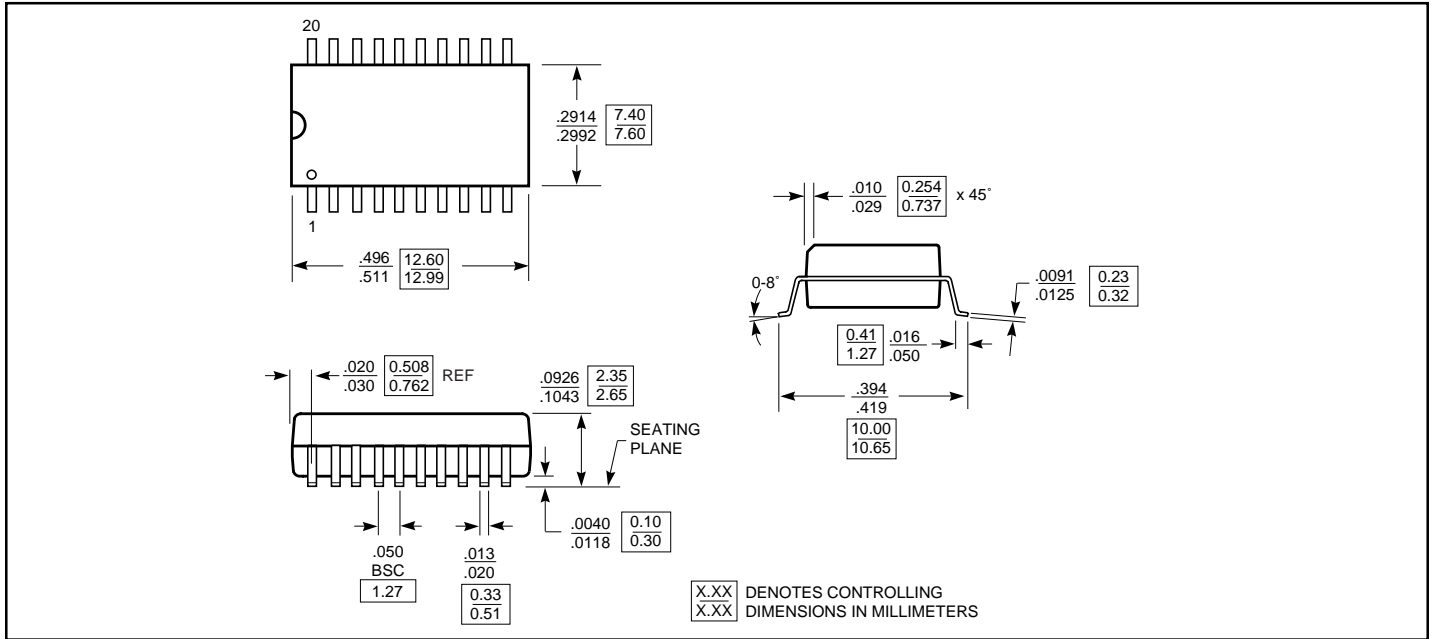

**Ordering Information**

| Ordering Data | Description                        |
|---------------|------------------------------------|
| PI74LVTC245H  | 20-pin, 209-mil wide plastic SSOP  |
| PI74LVTC245L  | 20-pin, 173-mil wide plastic TSSOP |
| PI74LVTC245S  | 20-pin, 300-mil wide plastic SOIC  |

**Notes:**

- Thermal characteristics can be found on the company web site at <http://www.pericom.com/packaging/mechanicals.php>