

High-Speed Differential Line Receivers

Features

- Sixteen line receivers meet or exceed the requirements of the ANSITIA/EIA-644-1995 Standard
- Designed for signaling rates up to 660 Mbps
- 0V to 3V common-mode input voltage range
- Operates from a single 3.3V supply
- Typical propagation delay time: 2.6ns
- Output skew 100ps (typical)
- Part-to-part skew is less than 1ns
- Integrated 110-Ohm termination on PI90LVT386
- Low Voltage TTL (LVTTTL) levels are 5V tolerant
- Open-circuit fail safe
- Flow-through pin out
- Packaging (Pb-free & Green available):
- 64-Pin Thin Shrink Small Output TSSOP (A)

Pin Configuration

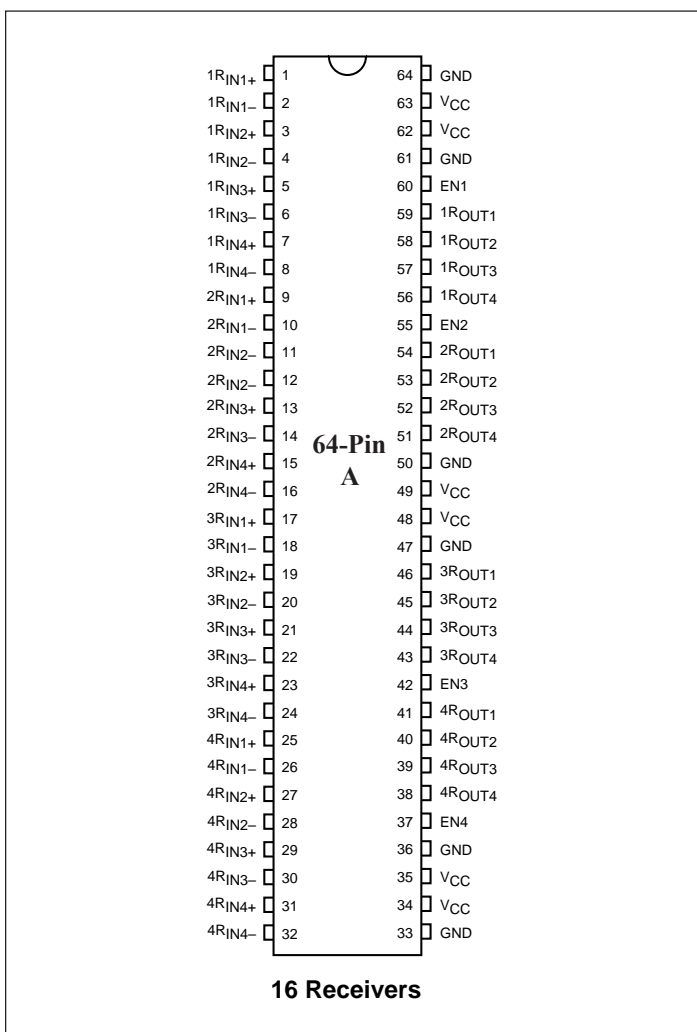

Description

The PI90LVx386 family consists of sixteen differential line receivers with 3-state outputs that implement Low-Voltage Differential Signaling (LVDS). Any of the differential receivers will provide a valid logical output state with a ±100mV differential input voltage within the input common-mode voltage range that allows 0 to 3V of ground potential difference between two LVDS nodes. The independent EN pins can be used to place the outputs in either a normal logic state (high or low logic levels) or a high-impedance state. In high-impedance state, outputs neither load nor drive the bus lines.

The intended application of these devices, and their signaling techniques, is for point-to-point baseband data transmission over controlled impedance media of approximately 100-ohms with a 100-Ohm termination resistor. The PI90LVT386 integrates the terminating resistors while the PI90LV386 requires external resistors. The transmission media may be printed circuit board traces, backplanes, or cables. The PI90LV386's 16 receivers integrated into the same substrate allow precise timing alignment.

These parts are characterized for operation from -40°C to 85°C.

Block Diagram

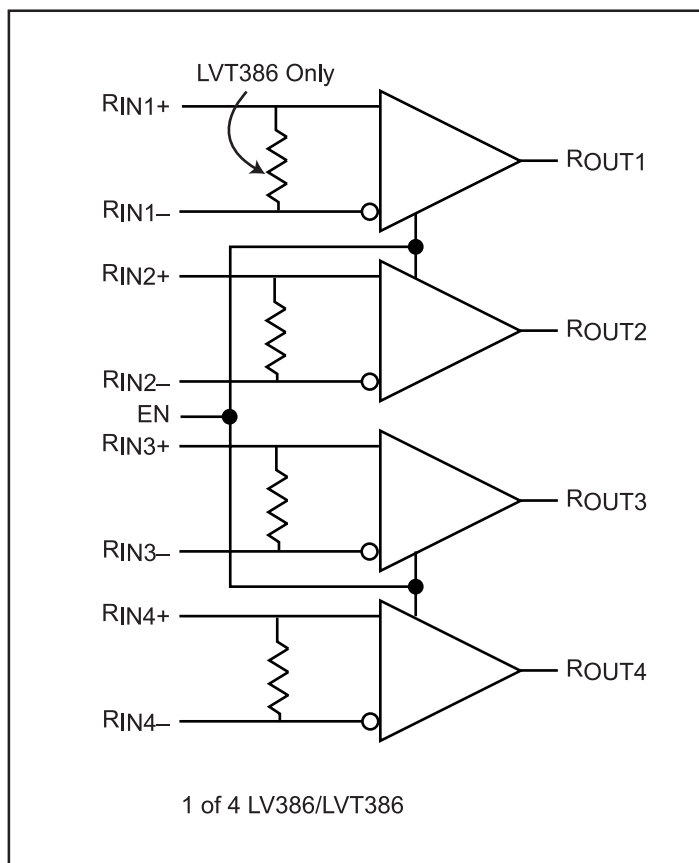

Absolute Maximum Ratings
Over Operating Free-Air Temperature

(unless otherwise noted)[†]

Supply Voltage Range, $V_{DD}^{(1)}$	-0.5V to 4V
Voltage Range:	Enables or R_{OUT}
-0.5V to $V_{DD}+2V$	
R_{IN+} or R_{IN-}	-0.5V to 4V
Electrostatic Discharge ⁽²⁾ :	
R_{IN+} , R_{IN-} , and GND	Class 3, A: 10kV, B: 700V
All Pins	Class 3, A: 8kV, B: 600V
Storage Temperature Range	-65°C to 150°C
Lead Temperature 1, 6mm (1/16 inch)	
from case for 10 seconds	260°C

† Stresses beyond those listed under “Absolute Maximum Ratings” may cause permanent damage to the device. These are stress ratings only, and functional operation of the device at these or any other conditions beyond those indicated under "Recommended Operating Conditions" is not implied. Exposure to Absolute-Maximum-Rated conditions for extended periods may affect device reliability.

Notes:

1. All voltage values, except differential I/O bus voltages, are with respect to ground terminal.
2. Tested in accordance with MIL-STD-883C Method 3015.7

Function Table

Differential Input	Enables	Output
$R_{IN\pm}$	EN	R_{OUT}
$V_{ID} \geq 100mV$	H	H
$-100mV < V_{ID} \leq 100mV$	H	?
$V_{ID} \leq -100mV$	H	L
X	L	Z
Open	H	H
X	H	R_{OUT0}

Notes:

H = high level, L = low level, X = irrelevant
Z = high impedance (off), ? = indeterminate

Recommended Operating Conditions

	Min.	Nom.	Max.	Units
Supply Voltage, V_{CC}	3.0	3.3	3.6	V
High-Level Input Voltage, V_{IH}	2.0			
Low-Level Input Voltage, V_{IL}			0.8	
Magnitude of Differential Input Voltage $ V_{ID} $	0.1		0.6	
Common-Mode input Voltage, V_{IC}	$\frac{ V_{ID} }{2}$		$2.4 - \frac{ V_{ID} }{2}$	
			$V_{CC} - 0.8$	
Operating free-air temperature, T_A	-40		85	°C

Electrical Characteristics Over Recommended Operating Conditions (unless otherwise noted)

Symbol	Parameter	Test Conditions	Min.	Typ. ⁽¹⁾	Max.	Units	
V _{I TH+}	Positive-going differential input voltage threshold				100	mV	
V _{I TH-}	Negative-going differential input voltage threshold		-100				
V _{OH}	High-level output voltage	I _{OH} = -8mA	2.4	3.1		V	
V _{OL}	Low-level output voltage	I _{OL} = 8mA		0.3	0.45		
I _{CC}	Supply Current	Enabled, No load		40	56	mA	
		Disabled			3		
I _I	Input Current (R _{IN+} or R _{IN-} inputs)	LV	V _I = 0V			-20	μA
			V _I = 2.4V	-1.2			
		LVT	V _I = 0V, other input open			-40	
			V _I = 2.4V, other input open	-2.4			
I _{I(OFF)}	Power-off input current (R _{IN+} or R _{IN-} inputs)	V _{CC} = 0V, V _I = 2.4V		12	±20		
I _{IH}	High-level input current (enables)	V _{IH} = 2V			10		
I _{IL}	Low-level input current (enables)	V _{IL} = 0.8V					
I _{OZ}	High-impedance output current	V _O = 0V			±1		
		V _O = 3.6V			10		
C _{IN}	Input capacitance (R _{IN+} or R _{IN-} inputs to GND)	V _{ID} = 0.4 sin 2.5E09 t V		6		pF	
Z _(t)	Termination Impedance (LVT)		88	110	143	Ohms	

Note:

- All typical values are at 25°C and with a 3.3V supply.

Switching Characteristics Over Recommended Operating Conditions (unless otherwise noted)

Symbol	Parameter	Test Conditions	Min.	Typ. ⁽¹⁾	Max.	Units
t _{PLH}	Propagation delay time, low-to-high-level output	See Figure 2	1	2.2	3.1	ns
t _{PHL}	Propagation delay time, high-to-low-level output		1	2.1	3.1	
t _r	Differential output signal rise time		500	900	1500	ps
t _f	Differential output signal fall time		500	820	1200	
t _{sk(p)}	Pulse skew (t _{PHL} – t _{PLH})			120	244	
t _{sk(o)}	Output skew ⁽²⁾				180	320
t _{sk(pp)}	Part-to-part skew ⁽³⁾				1	
t _{PZH}	Propagation delay time, high-impedance-to-high-level output	See Figure 3 ⁽⁴⁾		2.5	3.7	ns
t _{PZL}	Propagation delay time, high-impedance-to-low-level output			4.8	6.7	
t _{PHZ}	Propagation delay time, high-level-to-high-impedance output			3.7	5.3	
t _{PLZ}	Propagation delay time, low-level-to-high-impedance output			6.4	8.7	
f _{MAX}	Maximum Clock frequency		300			MHz

Notes:

1. All typical values are at 25°C and with a 3.3V supply
2. t_{sk(o)} is the magnitude of the time difference between the t_{PLH} or t_{PHL} of all drivers of a single device with all of their inputs connected together.
3. t_{sk(pp)} is the magnitude of the difference in propagation delay times between any specified terminals of two devices when both devices operate with the same supply voltages, at the same temperature, and have identical packages and test circuits.
4. R_{OUT0} disable time is 1 nanosecond greater.

Parameter Measurement Information

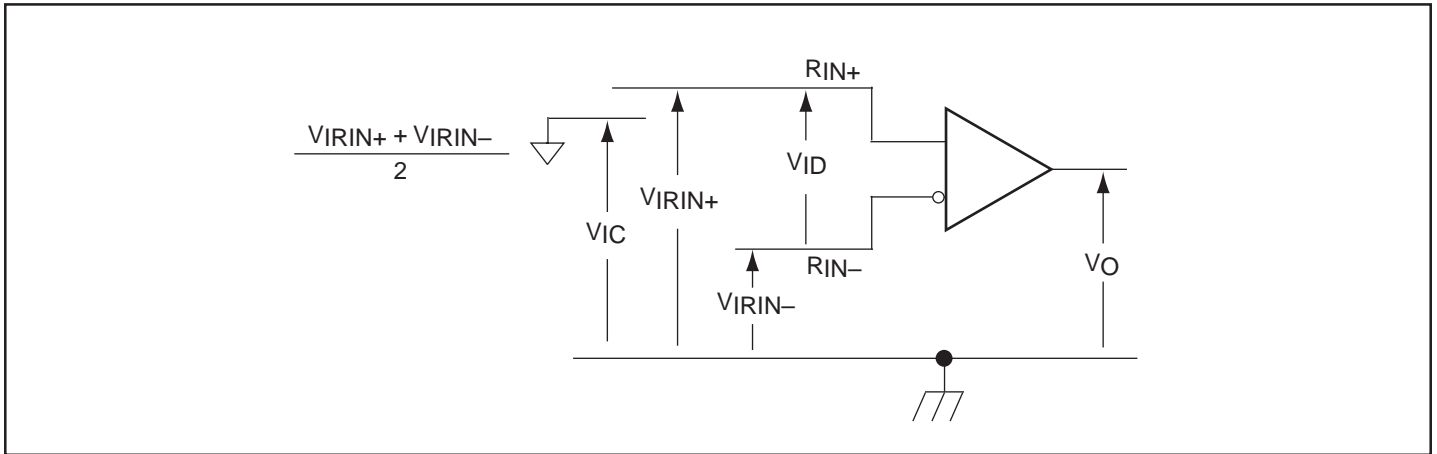

Figure 1. Voltage Definitions

Table 1. Receiver Minimum and Maximum Input Threshold Test Voltages

Applied Voltages		Resulting Differential Input Voltage	Resulting Common-Mode Input Voltage
V_{IRIN+}	V_{IRIN-}	V_{ID}	V_{IC}
1.25V	1.15V	100mV	1.2V
1.15V	1.25V	-100mV	1.2V
2.4V	2.3V	100mV	2.35V
2.3V	2.4V	-100mV	2.35V
0.1V	0V	100mV	0.05V
0V	0.1V	-100mV	0.05V
1.5V	0.9V	600mV	1.2V
0.9V	1.5V	-600mV	1.2V
2.4V	1.8V	600mV	2.1V
1.8V	2.4V	-600mV	2.1V
0.6V	0V	600mV	0.3V
0V	0.6V	-600mV	0.3V

Parameter Measurement Information

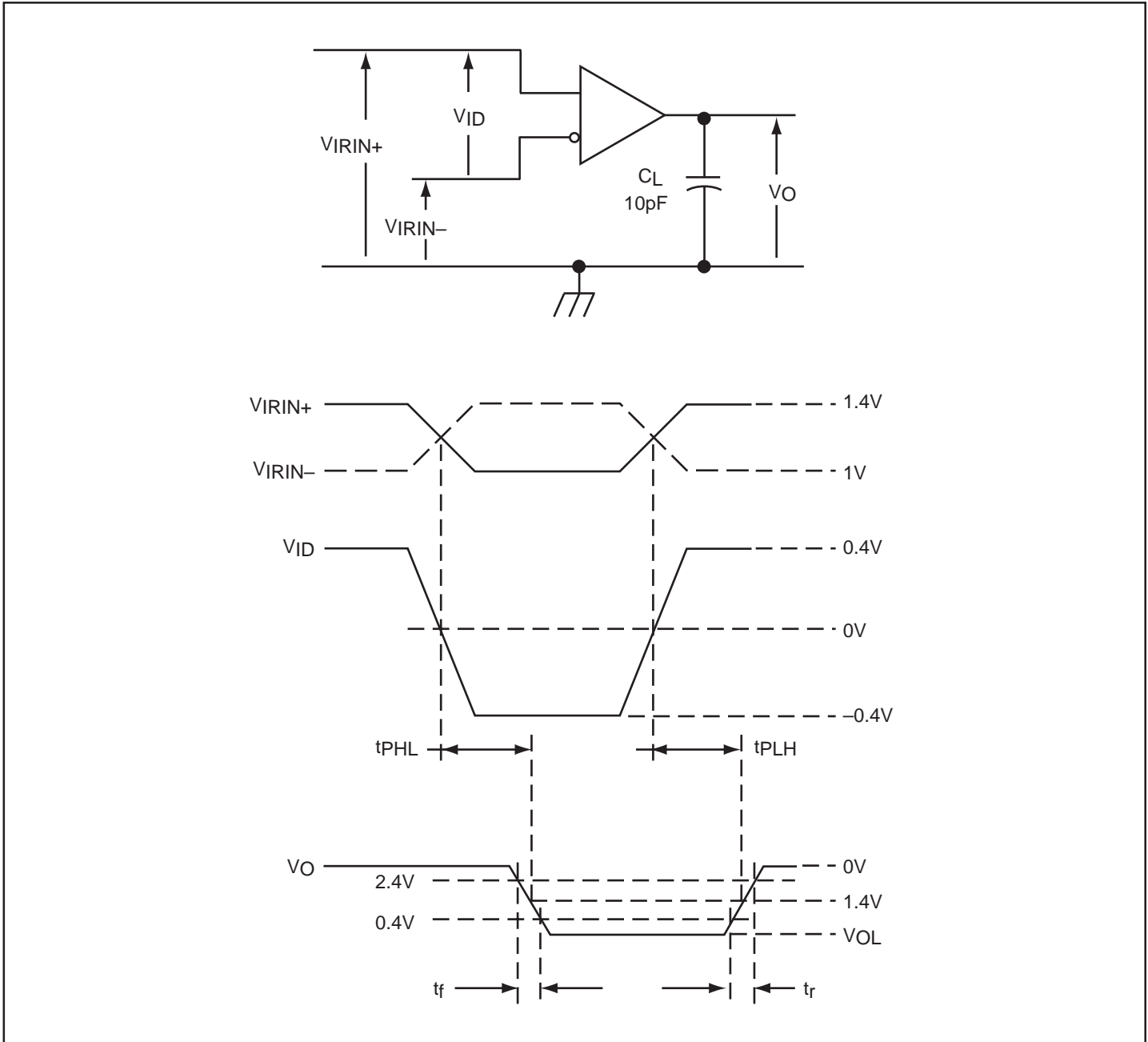
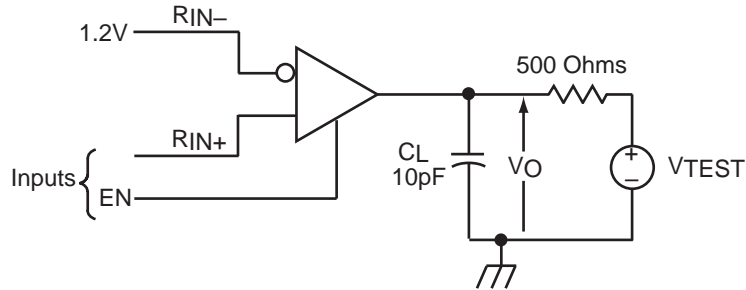

Figure 2. Timing Test Circuit and Waveforms

Note:

1. All input pulses are supplied by a generator having the following characteristics: t_r or $t_f \leq 1\text{ns}$, Pulse Repetition Rate (PRR) = 50 Mpps, Pulse width = $10 \pm 0.2\text{ns}$. C_L includes instrumentation and fixture capacitance within 0.06m of the D.U.T.

Parameter Measurement Information



Note:

- All input pulses are supplied by a generator having the following characteristics: t_r or $t_f \leq 1\text{ns}$, Pulse Repetition Rate (PRR) = 0.5 Mpps, pulse width = $500 \pm 10\text{ns}$. C_L includes instrumentation and fixture capacitance within 0.06m of the D.U.T.

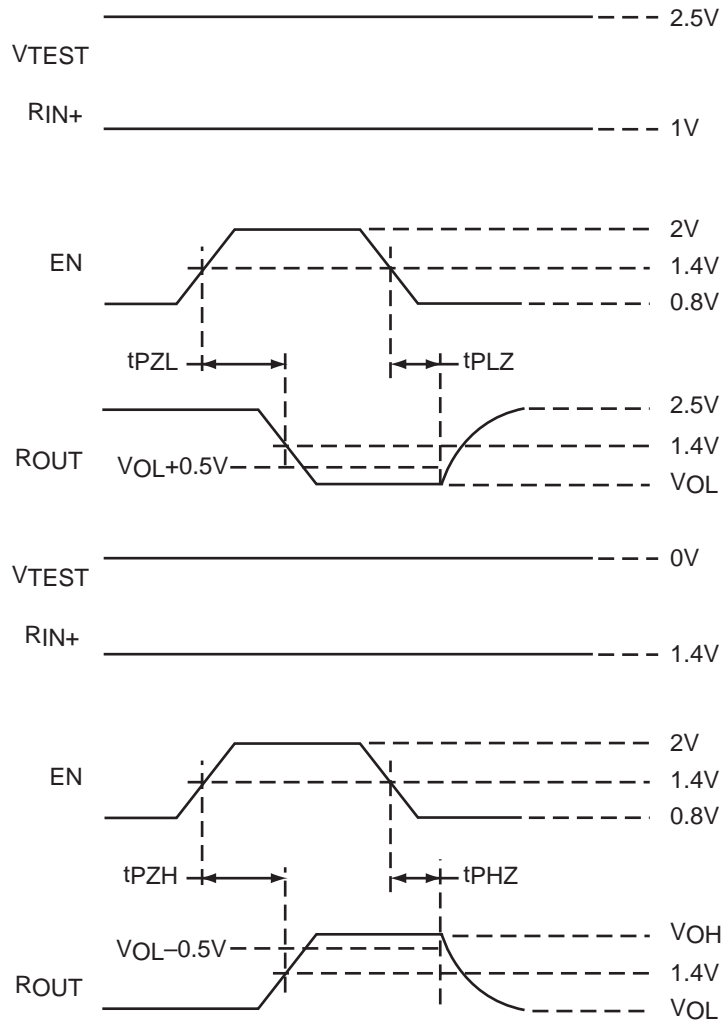
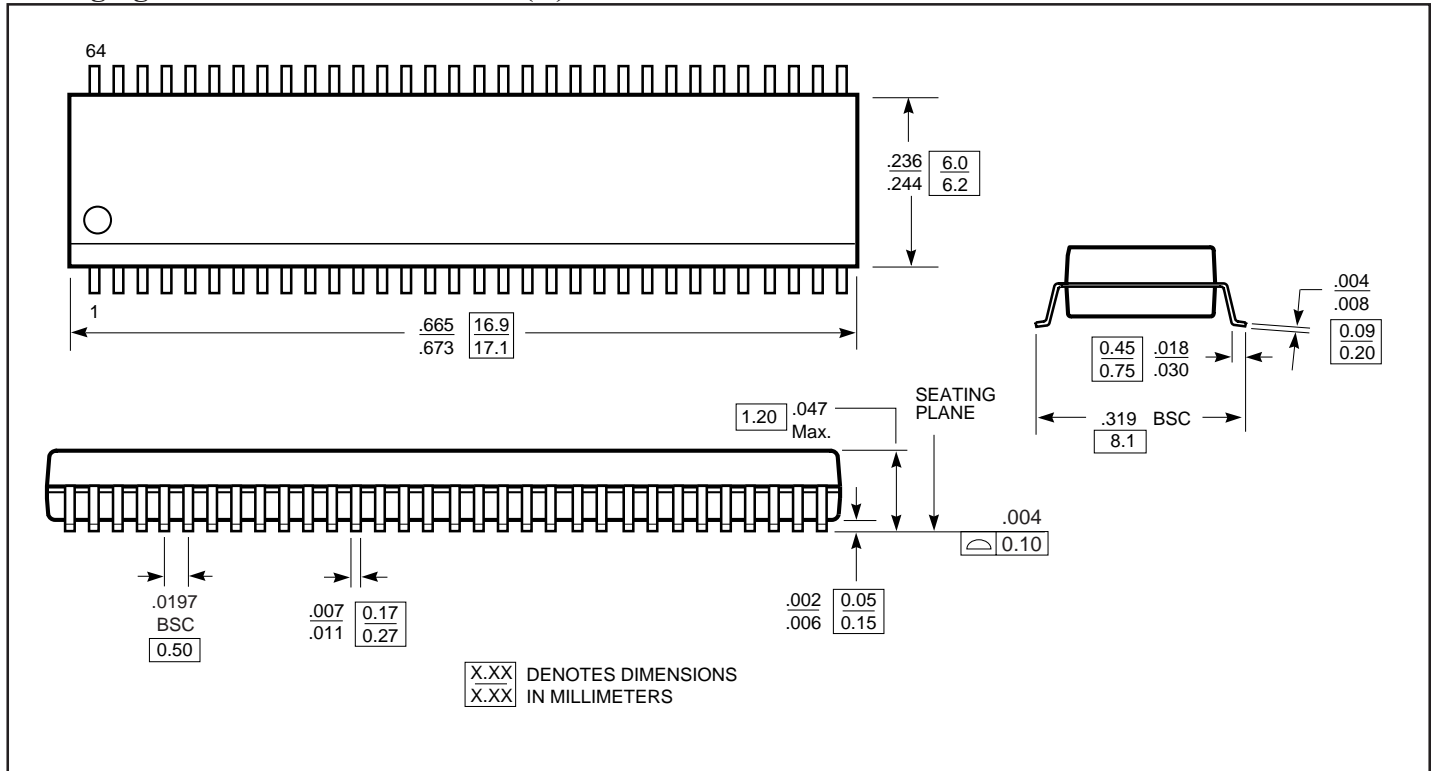

Figure 3. Enable/Disable Test Circuit and Waveforms

Packaging Mechanical: 64-Pin TSSOP (A)



Ordering Information

Ordering Code	Package Code	Package Type
PI90LV368A	A	64-pin TSSOP
PI90LV368AE	A	Pb-free & Green, 64-pin TSSOP
PI90LVT368A	A	64-pin TSSOP
PI90LVT368AE	A	Pb-free & Green, 64-pin TSSOP

Notes:

1. Thermal characteristics can be found on the company web site at www.pericom.com/packaging/
2. X = Tape and reel