

HA16654A, HA16664A Series

PWM Controlled Switching Regulator

HITACHI

ADE-204-055 (Z)

Rev. 0

Dec. 2000

The HA16654A and HA16664A are PWM control switching regulator ICs which drive a power MOSFET at high speed and high frequency. The standby current is limited to as small as 1.5 mA (typ). These devices incorporate totem pole circuits suited for high-speed push-pull operation at the output stage, accomplishing high-speed switching with rising time $t_r = 80$ ns (typ) and falling time $t_f = 40$ ns (typ) at 20 V swing.

Functions

- Reference voltage circuit
- Triangular waveform oscillation circuit
- PWM comparator circuit
- Low-input malfunction protection circuit
- Output drive circuit
- Soft start and quick shut down

Features

- High speed switching: $t_r = 80$ ns, $t_f = 40$ ns (typ) when use external driver circuit
- High frequency operation:
HA16654A ($f = 100$ kHz to 500 kHz)
HA16664A ($f = 100$ kHz to 200 kHz)
Low power dissipation : 2 mA max in standby state
- 5 V reference voltage
- Low-input malfunction protection (High threshold voltage: 10 V Typ, Low threshold voltage: 8 V Typ)
- Adjustable dead band width
- Enlarged output pulse width control range (0 to 80%)
- Soft start and quick shut down functions
- Single output: totem pole

Ordering Information

Type No.	Operating Frequency	Package
HA16654APS	100 kHz to 500 kHz	DP-8
HA16654AFP		FP-14DA
HA16664APS	100 kHz to 200 kHz	DP-8
HA16664AFP		FP-14DA

Pin Arrangement

- HA16654APS, HA16664APS

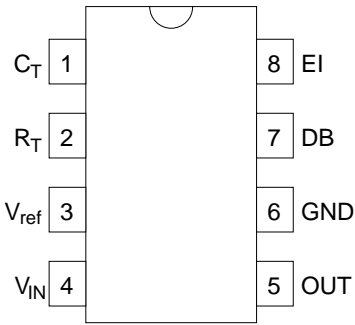

(Top view)

- HA16654AFP, HA16664AFP

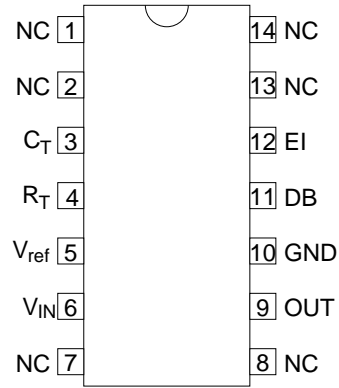

(Top view)

Table 1 Pin Function

Symbol	Pin Name
C_T	Timing capacitor
R_T	Timing resistor
V_{ref}	Reference voltage
V_{IN}	Input voltage
EI	Error input
DB	Dead band
GND	Ground
OUT	Driver output

Block Diagram

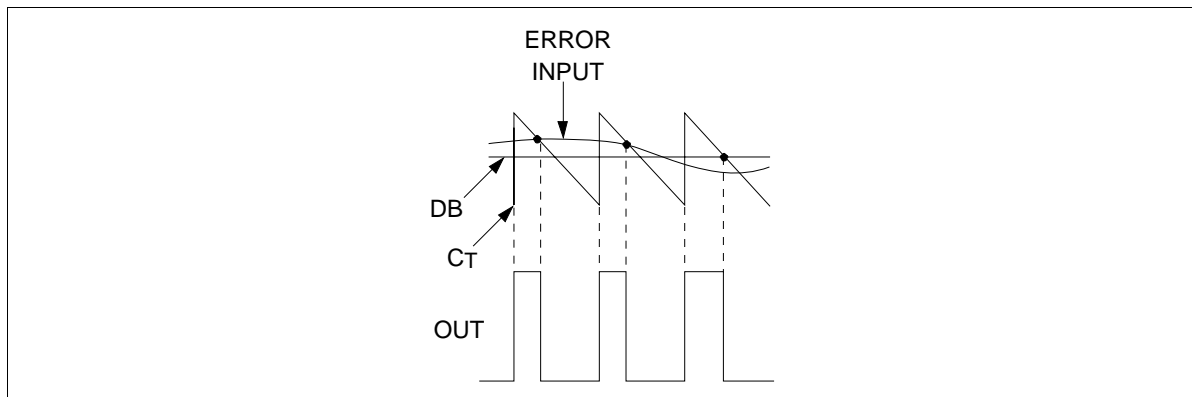
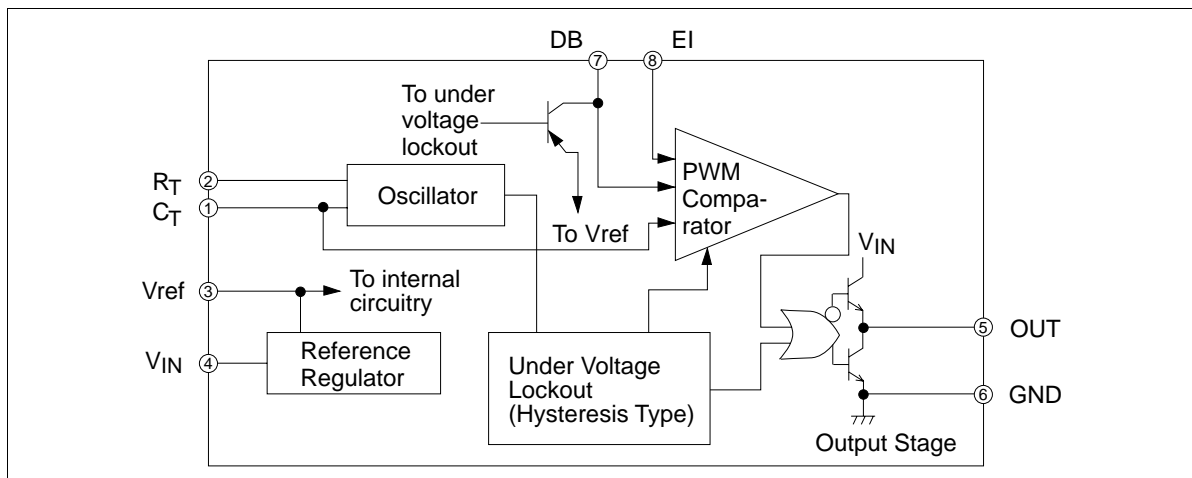

Figure 1 Waveform Timing

HA16654A, HA16664A Series

Absolute Maximum Ratings (Ta = 25°C)

Item	Symbol	Rating	Unit	Notes
Power supply voltage	V _{IN}	+40	V	
Collector current (Push-pull)	I _O	20	mA	
Comparator input voltage	V _{COM}	V _{ref} + 0.3	V	
R _T input current	I _{RT}	1	mA	
Power dissipation	P _T	680	mW	1, 2
Operation temperature range	Topr	-20 to +85	°C	
Storage temperature range	Tstg	-55 to 125	°C	

Notes: 1. Ta ≤ 45°C, if Ta > 45°C, derate by 8.3 mW/°C

2. T_{jmax} = θ_{j-a} • P_{cmax} + Ta (θ_{j-a}: Thermal resistance between junction and atmosphere at set board use)

The wiring density and the material of the set board must be chosen for thermal conductance of efficacy board.

Electrical Characteristics

HA16654APS/AFP (Ta = 25°C, V_{IN} = 20 V, C_T = 220 pF, R_T = 27 kΩ at f = 500 kHz)

Voltage Reference

Item	Symbol	Min	Typ	Max	Unit	Test Condition
Output voltage	V _{ref}	4.75	5.00	5.25	V	
Line regulation	Line	—	—	100	mV	V _{IN} = 7.3 to 11 V
		—	10	25	mV	V _{IN} = 11 to 40 V
Load regulation	Load	—	5	16	mV	I _O = 0 to 10 mA
Temperature stability	V _{RTC}	—	-26	—	ppm/°C	
Short circuit current	I _{OS}	10	35	—	mA	V _{ref} = 0 V

HITACHI

Oscillator

Item	Symbol	Min	Typ	Max	Unit	Test Condition
Maximum frequency	f_{\max}	500	—	—	kHz	$C_T = 220 \text{ pF}$
Minimum frequency	f_{\min}	—	—	100	kHz	$C_T = 560 \text{ pF}$
Initial accuracy	f_{dev}	—	—	± 10	%	
Voltage stability	f_{av}	—	-0.02	± 1.0	kHz/V	$V_{\text{IN}} = 11 \text{ to } 40 \text{ V}$

PWM

Item	Symbol	Min	Typ	Max	Unit	Test Condition
Maximum duty cycle	Du	80	—	—	%	
Duty cycle accuracy	Ddev	—	± 1	± 6	%	$R_1 = 13 \text{ k}\Omega, R_2 = 39 \text{ k}\Omega$
Input bias current	I_B	—	—	2.0	μA	$V_{E1} = 4 \text{ V}, V_{DB} = 0 \text{ V}$ or $V_{E1} = 0 \text{ V}, V_{DB} = 4 \text{ V}$

Output Driver

Item	Symbol	Min	Typ	Max	Unit	Test Condition
Sink current at Vin low	$I_{\text{OS(Low)}}$	0.6	1.5	—	mA	$V_{\text{IN}} = 6 \text{ V}, V_{\text{OUT}} = 0.4 \text{ V}$
Output low level	V_{OL}	—	0.86	1.4	V	$I_{\text{O(sink)}} = 10 \text{ mA}$
Output high level	V_{OH}	$V_{\text{IN}} - 2.2$	—	—	V	$I_{\text{O(source)}} = 10 \text{ mA}$
Output rising time	t_r	—	80	150	ns	Figure 3
Output falling time	t_f	—	40	100	ns	Figure 3
High level threshold	V_{THH}	9	10	11	V	UVL characteristics
Low level threshold	V_{THL}	7.3	8	9	V	UVL characteristics
Hysteresis width	V_{HRS}	1.5	2.0	2.5	V	UVL characteristics

Total Current

Item	Symbol	Min	Typ	Max	Unit	Test Condition
Standby current	I_{CCS}	—	1.5	2.0	mA	Figure 2
Operation current	V_{CCL}	5.0	9.0	13.0	mA	$R_1 = 13 \text{ k}\Omega, R_2 = 29 \text{ k}\Omega,$ $V_{\text{IN}} = 20 \text{ V}$ Figure 2

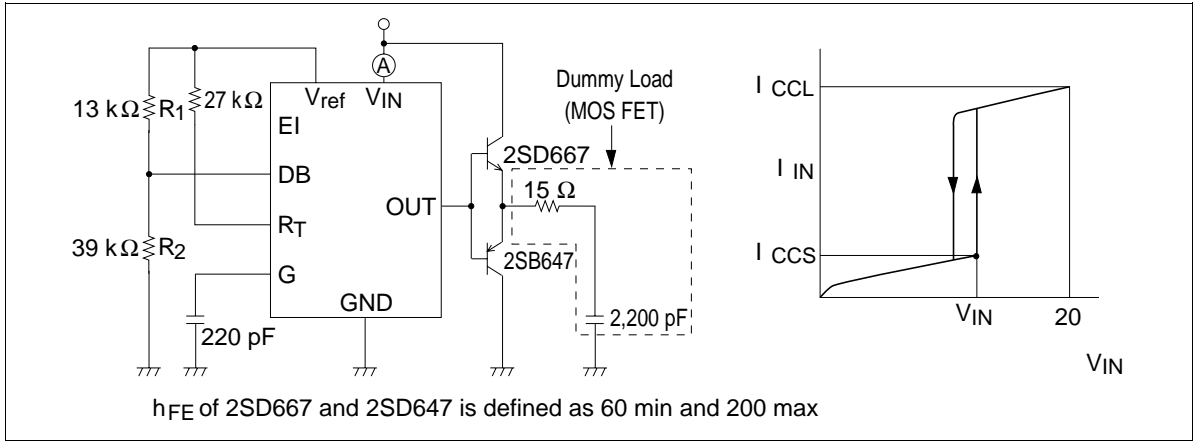

Figure 2 $I_{CCS} \cdot I_{CCL}$ Measurement Circuit

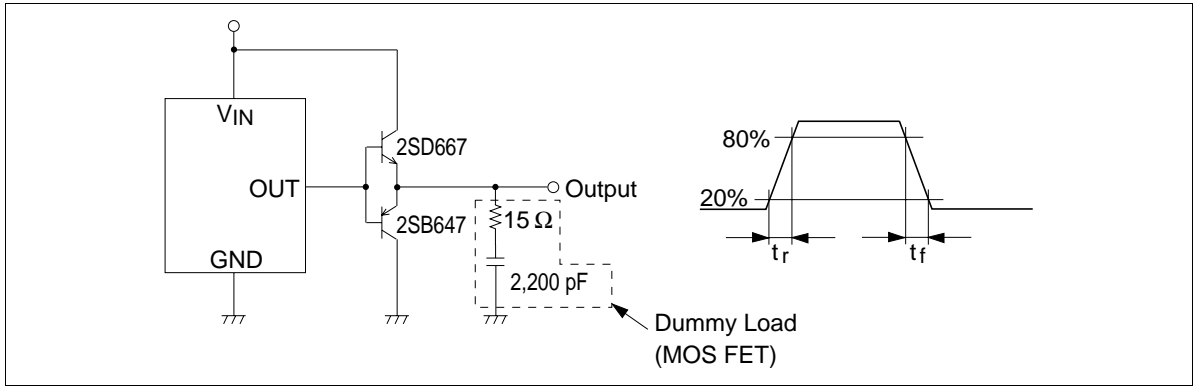

Figure 3 t_r, t_f Measurement Circuit

HA16664APS/AFP ($T_a = 25^\circ\text{C}$, $V_{IN} = 20\text{ V}$, $C_T = 560\text{ pF}$, $R_T = 82\text{ k}\Omega$ at $f = 100\text{ kHz}$)

Voltage Reference

Item	Symbol	Min	Typ	Max	Unit	Test Condition
Output voltage	V_{ref}	4.75	5.00	5.25	V	
Line regulation	Line	—	—	100	mV	$V_{IN} = 7.3\text{ to }11\text{ V}$
		—	10	25	mV	$V_{IN} = 11\text{ to }40\text{ V}$
Load regulation	Load	—	5	16	mV	$I_O = 0\text{ to }10\text{ mA}$
Temperature stability	V_{RTC}	—	-26	—	ppm/ $^\circ\text{C}$	
Short circuit current	I_{OS}	10	35	—	mA	$V_{ref} = 0\text{ V}$

Oscillator

Item	Symbol	Min	Typ	Max	Unit	Test Condition
Maximum frequency	f_{\max}	200	—	—	kHz	$C_T = 220 \text{ pF}$
Minimum frequency	f_{\min}	—	—	100	kHz	$C_T = 560 \text{ pF}$
Initial accuracy	f_{dev}	—	—	± 10	%	
Voltage stability	f_{av}	—	-0.02	± 1.0	kHz/V	$V_{\text{IN}} = 11 \text{ to } 40 \text{ V}$

PWM Comparator

Item	Symbol	Min	Typ	Max	Unit	Test Condition
Maximum duty cycle	Du	80	—	—	%	
Duty cycle accuracy	Ddev	—	± 1.0	± 6	%	$R_1 = 11 \text{ k}\Omega, R_2 = 39 \text{ k}\Omega$
Input bias current	I_B	—	—	2.0	μA	$V_{\text{EI}} = 4 \text{ V}, V_{\text{DB}} = 0 \text{ V}$ or $V_{\text{EI}} = 0 \text{ V}, V_{\text{DB}} = 4 \text{ V}$

Output Driver

Item	Symbol	Min	Typ	Max	Unit	Test Condition
Sink current at Vin low	$I_{\text{OS(Low)}}$	1.0	1.5	—	mA	$V_{\text{IN}} = 6 \text{ V}, V_{\text{OUT}} = 0.4 \text{ V}$
Output low level	V_{OL}	—	0.86	1.4	V	$I_{\text{O(sink)}} = 10 \text{ mA}$
Output high level	V_{OH}	$V_{\text{IN}} - 2.2$	—	—	V	$I_{\text{O(source)}} = 10 \text{ mA}$
Output rising time	t_r	—	80	300	ns	Figure 5
Output falling time	t_f	—	40	200	ns	Figure 5
High level threshold	V_{THH}	9	10	11	V	UVL characteristics
Low level threshold	V_{THL}	7.3	8	9	V	UVL characteristics
Hysteresis width	V_{HRS}	1.5	2.0	2.5	V	UVL characteristics

Total Current

Item	Symbol	Min	Typ	Max	Unit	Test Condition
Standby current	I_{CCS}	—	1.5	2.0	mA	Figure 4
Operation current	V_{CCL}	3.0	5.0	7.0	mA	$R_1 = 11 \text{ k}\Omega, R_2 = 39 \text{ k}\Omega,$ $V_{\text{IN}} = 20 \text{ V}$ Figure 4

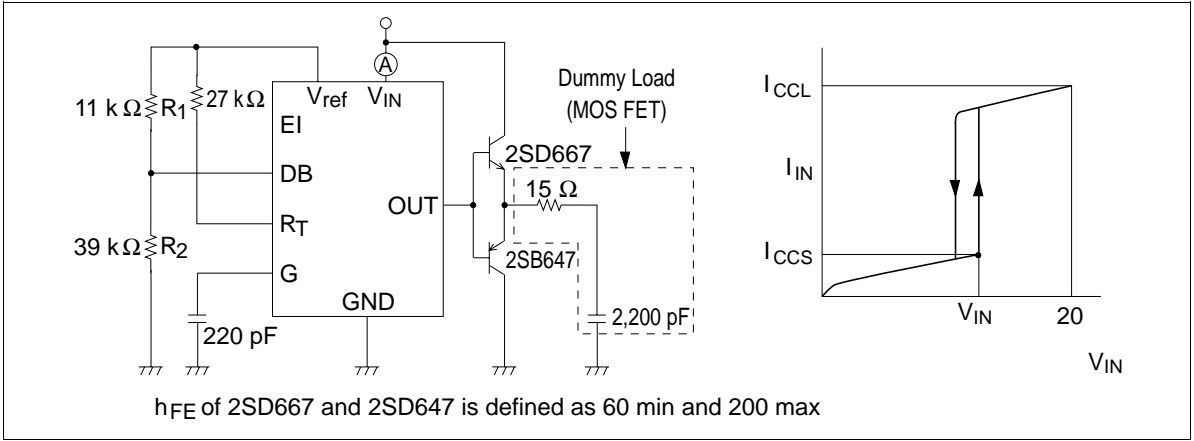

Figure 4 I_{CCS} • I_{CCL} Measurement Circuit

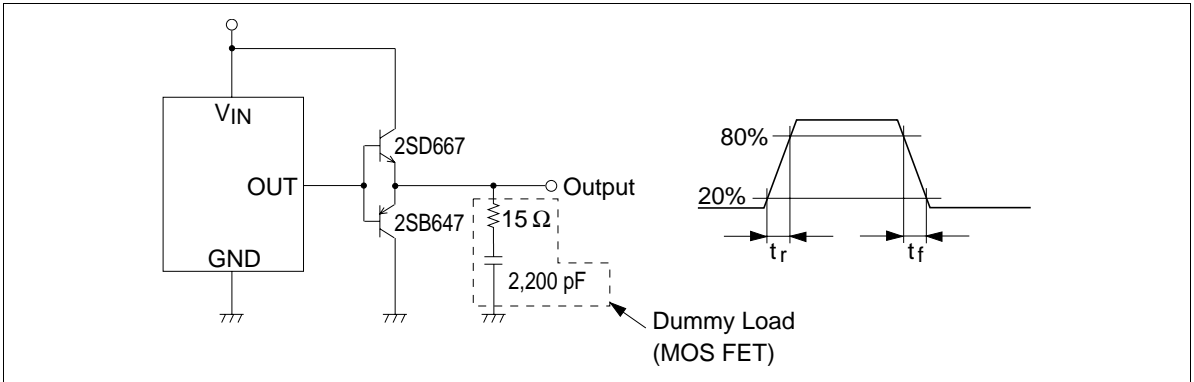
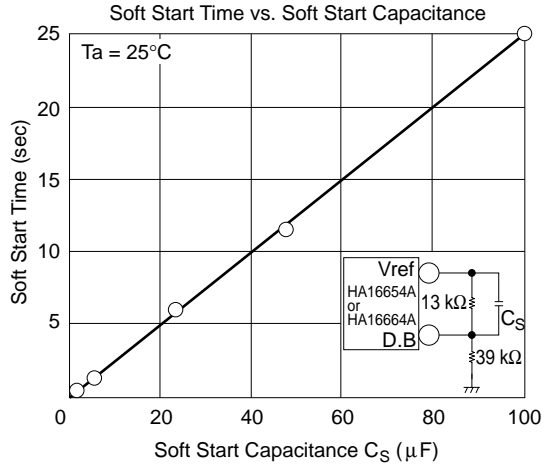
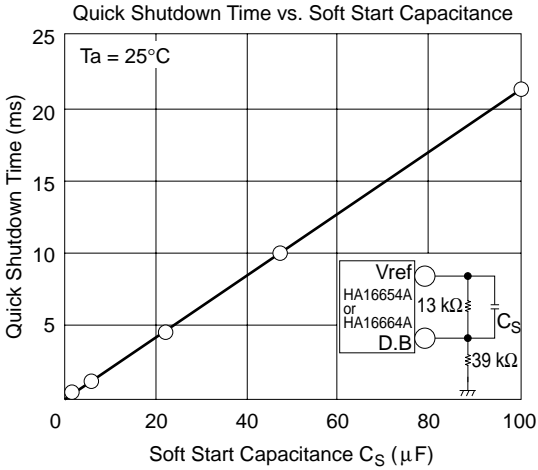
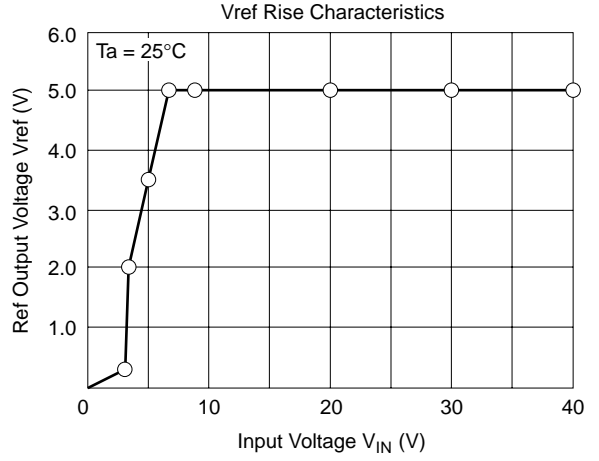
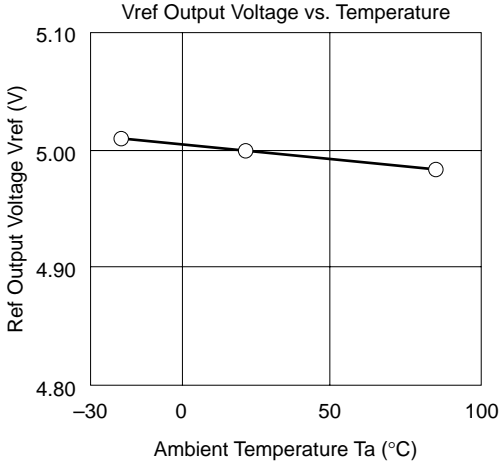
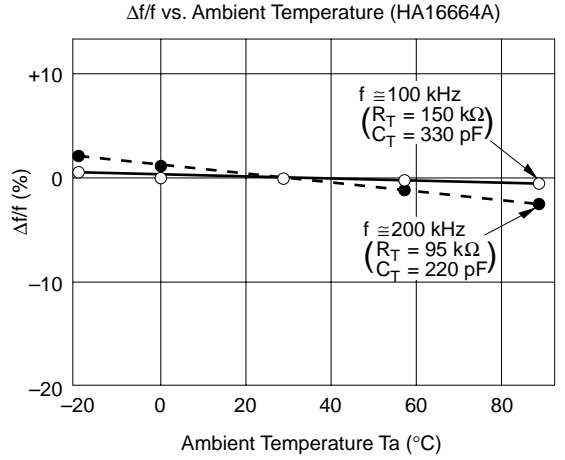
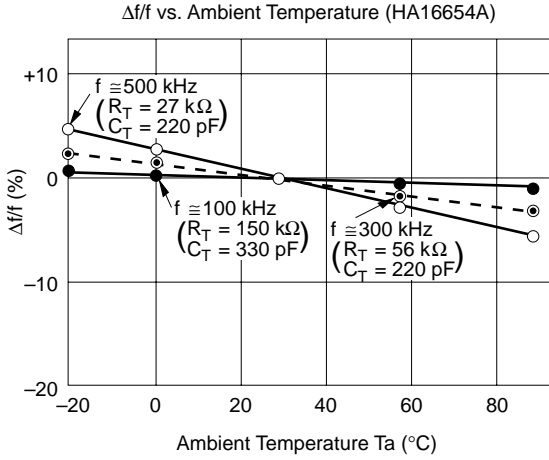
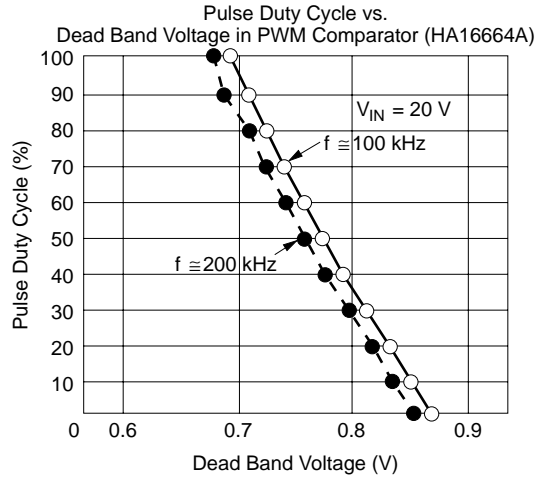
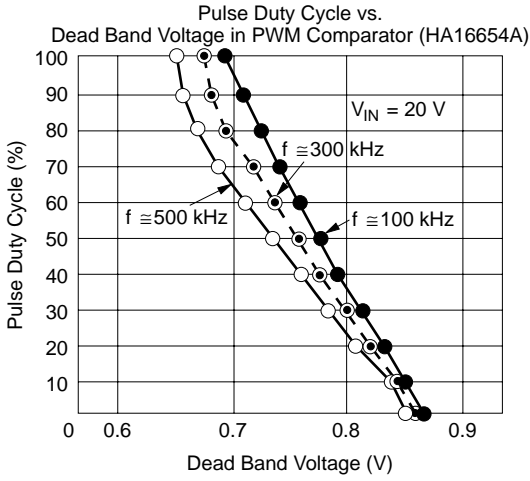

Figure 5 t_r • t_f Measurement Circuit

Characteristic Curves





Pulse Duty Cycle vs. Ambient Temperature (HA16654A)

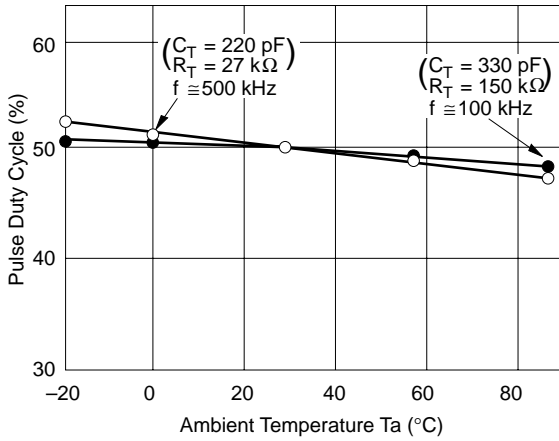

Δ ton/ton vs. Ambient Temperature (HA16654A)

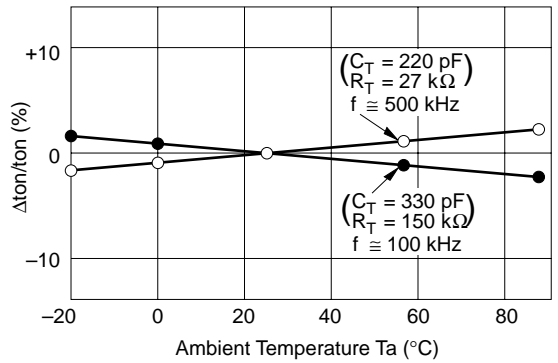

Pulse Duty Cycle vs. Ambient Temperature (HA16664A)

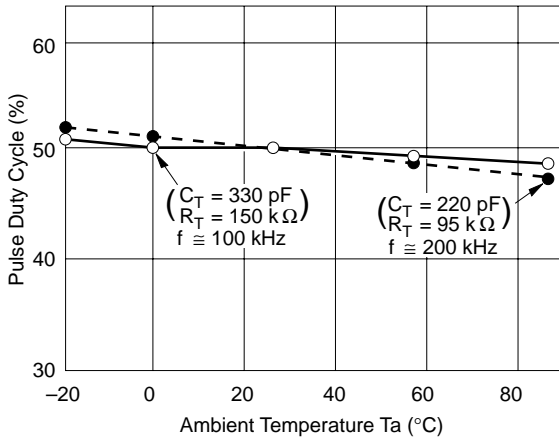

Δ ton/ton vs. Ambient Temperature (HA16664A)

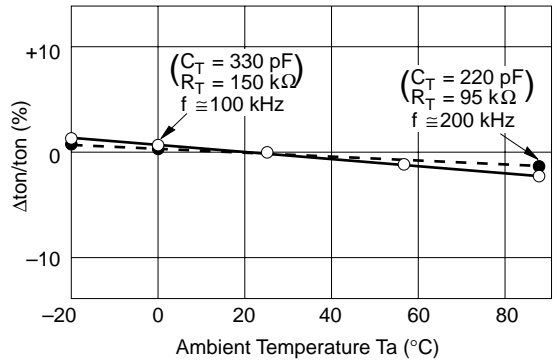

OSC Frequency vs. Timing Resistor (HA16654A)

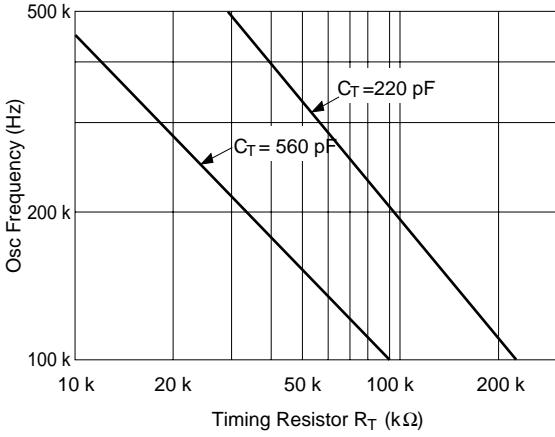

OSC Frequency vs. Timing Resistor (HA16664A)

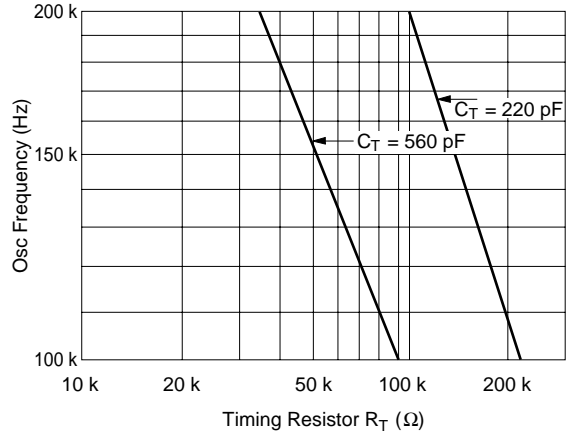

Formula for the oscillation frequency f

$$f = 1 / [\{ C_T (R_T + 1 \times 10^3) (a \cdot R_T + b) / (V_{ref} - V_{BE}) \} + 100 \times 10^{-9}]$$

C_T : Timing capacitor (F)

R_T : Timing resistor (Ω)

V_{ref} : Reference voltage 5.0 (V) (Typ)

V_{BE} : Base-emitter voltage 0.65 (V) (Typ)

The following table show empirical values of a and b for different values of C_T .

C_T (pF)	a	b
220	-2.30×10^{-6}	1.247
560	-8.37×10^{-6}	1.575

Also,

$$f \approx 4.35 / (C_T \cdot R_T)$$

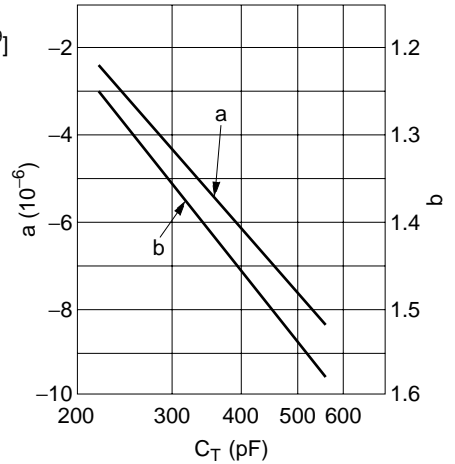

Package Dimensions

Unit: mm

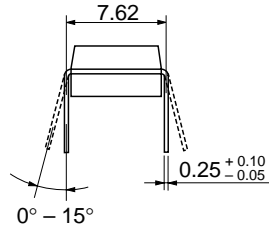
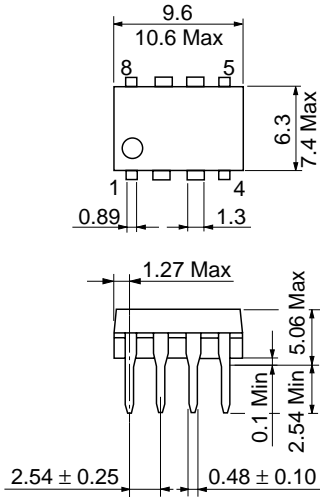

Hitachi Code	DP-8
JEDEC	Conforms
EIAJ	Conforms
Mass (reference value)	0.54 g

Unit: mm

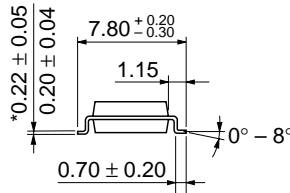
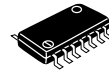
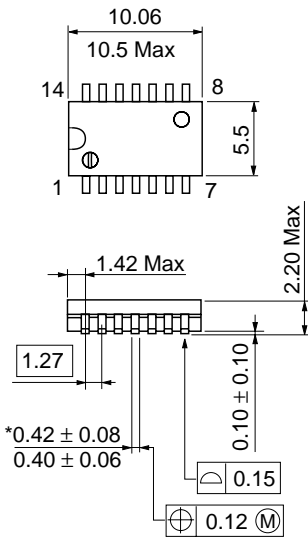

Hitachi Code	FP-14DA
JEDEC	—
EIAJ	Conforms
Mass (reference value)	0.23 g

*Dimension including the plating thickness
Base material dimension

Cautions

1. Hitachi neither warrants nor grants licenses of any rights of Hitachi's or any third party's patent, copyright, trademark, or other intellectual property rights for information contained in this document. Hitachi bears no responsibility for problems that may arise with third party's rights, including intellectual property rights, in connection with use of the information contained in this document.
2. Products and product specifications may be subject to change without notice. Confirm that you have received the latest product standards or specifications before final design, purchase or use.
3. Hitachi makes every attempt to ensure that its products are of high quality and reliability. However, contact Hitachi's sales office before using the product in an application that demands especially high quality and reliability or where its failure or malfunction may directly threaten human life or cause risk of bodily injury, such as aerospace, aeronautics, nuclear power, combustion control, transportation, traffic, safety equipment or medical equipment for life support.
4. Design your application so that the product is used within the ranges guaranteed by Hitachi particularly for maximum rating, operating supply voltage range, heat radiation characteristics, installation conditions and other characteristics. Hitachi bears no responsibility for failure or damage when used beyond the guaranteed ranges. Even within the guaranteed ranges, consider normally foreseeable failure rates or failure modes in semiconductor devices and employ systemic measures such as fail-safes, so that the equipment incorporating Hitachi product does not cause bodily injury, fire or other consequential damage due to operation of the Hitachi product.
5. This product is not designed to be radiation resistant.
6. No one is permitted to reproduce or duplicate, in any form, the whole or part of this document without written approval from Hitachi.
7. Contact Hitachi's sales office for any questions regarding this document or Hitachi semiconductor products.

HITACHI

Hitachi, Ltd.

Semiconductor & Integrated Circuits.
 Nippon Bldg., 2-6-2, Ohte-machi, Chiyoda-ku, Tokyo 100-0004, Japan
 Tel: Tokyo (03) 3270-2111 Fax: (03) 3270-5109

URL NorthAmerica : <http://semiconductor.hitachi.com/>
 Europe : <http://www.hitachi-eu.com/hel/ecg>
 Asia : <http://sicapac.hitachi-asia.com>
 Japan : <http://www.hitachi.co.jp/Sicd/indx.htm>

For further information write to:

Hitachi Semiconductor
 (America) Inc.
 179 East Tasman Drive,
 San Jose, CA 95134
 Tel: <1> (408) 433-1990
 Fax: <1> (408) 433-0223

Hitachi Europe GmbH
 Electronic Components Group
 Dornacher Straße 3
 D-85622 Feldkirchen, Munich
 Germany
 Tel: <49> (89) 9 9180-0
 Fax: <49> (89) 9 29 30 00

Hitachi Europe Ltd.
 Electronic Components Group.
 Whitebrook Park
 Lower Cookham Road
 Maidenhead
 Berkshire SL6 8YA, United Kingdom
 Tel: <44> (1628) 585000
 Fax: <44> (1628) 585160

Hitachi Asia Ltd.
 Hitachi Tower
 16 Collyer Quay #20-00,
 Singapore 049318
 Tel: <65>-538-6533/538-8577
 Fax : <65>-538-6933/538-3877
 URL : <http://www.hitachi.com.sg>

Hitachi Asia Ltd.
 (Taipei Branch Office)
 4/F, No. 167, Tun Hwa North Road,
 Hung-Kuo Building,
 Taipei (105), Taiwan
 Tel: <886>-(2)-2718-3666
 Fax : <886>-(2)-2718-8180
 Telex : 23222 HAS-TP
 URL : <http://www.hitachi.com.tw>

Hitachi Asia (Hong Kong) Ltd.
 Group III (Electronic Components)
 7/F., North Tower,
 World Finance Centre,
 Harbour City, Canton Road
 Tsim Sha Tsui, Kowloon,
 Hong Kong
 Tel : <852>-(2)-735-9218
 Fax : <852>-(2)-730-0281
 URL : <http://www.hitachi.com.hk>

Copyright © Hitachi, Ltd., 2000. All rights reserved. Printed in Japan.
 Colophon 2.0