

# HD74CDCV857

## 2.5-V Phase-lock Loop Clock Driver

# HITACHI

ADE-205-335E (Z)  
Preliminary  
6th Edition  
March 2001

### Description

The HD74CDCV857 is a high-performance, low-skew, low-jitter, phase locked loop clock driver. It is specifically designed for use with DDR (Double Data Rate) synchronous DRAMs.

### Features

- Supports 60 MHz to 200 MHz operation range
- Distributes one differential clock input pair to ten differential clock outputs pairs
- Supports spread spectrum clock requirements meeting the PC100 SDRAM registered DIMM specification
- External feedback pins ( $\overline{\text{FBIN}}$ ,  $\overline{\text{FBIN}}$ ) are used to synchronize the outputs to the clock input
- Supports 2.5V analog supply voltage ( $\text{AV}_{\text{CC}}$ ), and 2.5 V  $\text{V}_{\text{DDQ}}$
- No external RC network required
- Sleep mode detection
- 48pin TSSOP (Thin Shrink Small Outline Package)

### Function Table

Inputs				:	Outputs				:	PLL
$\text{AV}_{\text{CC}}$	$\overline{\text{PWRDWN}}$	CLK	$\overline{\text{CLK}}$	:	Y	$\overline{\text{Y}}$	FBOUT	$\overline{\text{FBOUT}}$	:	
GND	H	L	H	:	L	H	L	H	:	Bypassed / off <sup>*1</sup>
GND	H	H	L	:	H	L	H	L	:	Bypassed / off <sup>*1</sup>
X	L	L	H	:	Z	Z	Z	Z	:	off
X	L	H	L	:	Z	Z	Z	Z	:	off
2.5 V	H	L	H	:	H	L	H	L	:	on
2.5 V	H	H	L	:	H	L	H	L	:	on
2.5 V	X	0 MHz	0 MHz	:	Z	Z	Z	Z	:	off

H : High level

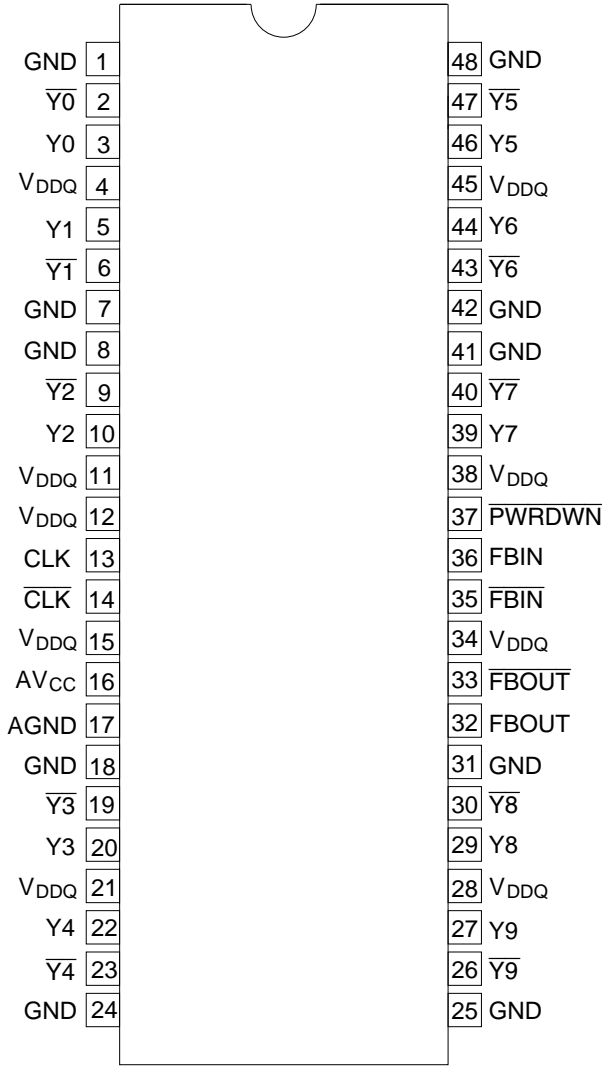
L : Low level

X : Don't care

Z : High impedance

Note: 1. Bypass mode is used for Hitachi test mode.

## Pin Arrangement

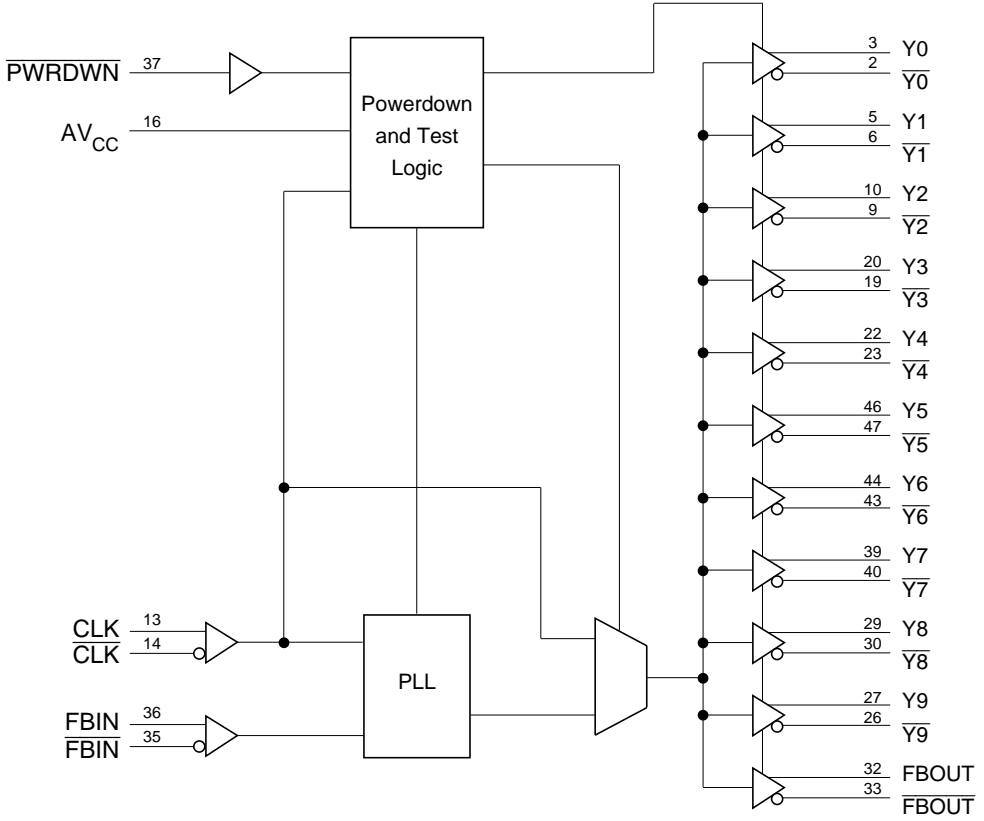


(Top view)

**Pin Function**

Pin name	No.	Type	Description
AGND	17	Ground	Analog ground. AGND provides the ground reference for the analog circuitry.
AV <sub>CC</sub>	16	Power	Analog power supply. AV <sub>CC</sub> provides the power reference for the analog circuitry. In addition, AV <sub>CC</sub> can be used to bypass the PLL for test purposes. When AV <sub>CC</sub> is strapped to ground, PLL is bypassed and CLK is buffered directly to the device outputs. This bypass mode is used for Hitachi test.
CLK, $\overline{\text{CLK}}$	13, 14	I Differential input	Clock input. CLK provides the clock signal to be distributed by the HD74CDCV857 clock driver. CLK is used to provide the reference signal to the integrated PLL that generates the clock output signals. CLK must have a fixed frequency and fixed phase for the PLL to obtain phase lock. Once the circuit is powered up and a valid CLK signal is applied, a stabilization time is required for the PLL to phase lock the feedback signal to its reference signal.
$\overline{\text{FBIN}}$ , FBIN	35, 36	I Differential input	Feedback input. FBIN provides the feedback signal to the internal PLL. FBIN must be hard-wired to FBOUT to complete the PLL. The integrated PLL synchronizes CLK and FBIN so that there is nominally zero phase error between CLK and FBIN.
FBOUT, $\overline{\text{FBOUT}}$	32, 33	O Differential output	Feedback output. FBOUT is dedicated for external feedback. It switches at the same frequency as CLK. When externally wired to FBIN, FBOUT completes the feedback loop of the PLL.
$\overline{\text{PWRDWN}}$	37	I	Output bank enable. $\overline{\text{PWRDWN}}$ is the output enable for all outputs. When $\overline{\text{PWRDWN}}$ is low, VCO will stop and all outputs are disabled to a high impedance state. When $\overline{\text{PWRDWN}}$ will be returned high, PLL will re-synchroniz to CLK frequency and all outputs are enabled.
GND	1, 7, 8, 18, 24, 25, 31, 41, 42, 48	Ground	Ground
V <sub>DDQ</sub>	4, 11, 12, 15, 21, 28, 34, 38, 45	Power	Power supply
Y	3, 5, 10, 20, 22, 27, 29, 39, 44, 46	O Differential output	Clock outputs. These outputs provide low-skew copies of CLK.
$\overline{\text{Y}}$	2, 6, 9, 19, 23, 26, 30, 40, 43, 47	O Differential output	Clock outputs. These outputs provide low-skew copies of $\overline{\text{CLK}}$ .

## Logic Diagram



Note: All inputs and outputs are associated with  $V_{DDQ} = 2.5\text{ V}$ .

**Absolute Maximum Ratings**

Item	Symbol	Ratings	Unit	Conditions
Supply voltage	$V_{DDQ}$	-0.5 to 3.6	V	
Input voltage	$V_I$	-0.5 to $V_{DDQ}+0.5$	V	
Output voltage <sup>1</sup>	$V_O$	-0.5 to $V_{DDQ}+0.5$	V	
Input clamp current	$I_{IK}$	-50	mA	$V_I < 0$
Output clamp current	$I_{OK}$	-50	mA	$V_O < 0$
Continuous output current	$I_O$	$\pm 50$	mA	$V_O = 0$ to $V_{DDQ}$
Supply current through each $V_{DDQ}$ or GND	$I_{VDDQ}$ or $I_{GND}$	$\pm 100$	mA	
Maximum power dissipation at $T_a = 55^\circ\text{C}$ (in still air)		0.7	W	
Storage temperature	$T_{stg}$	-65 to +150	$^\circ\text{C}$	

Notes: Stresses beyond those listed under "absolute maximum ratings" may cause permanent damage to the device. These are stress ratings only, and functional operation of the device at these or any other conditions beyond those indicated under "recommended operating conditions" is not implied. Exposure to absolute maximum rated conditions for extended periods may affect device reliability.

1. The input and output negative voltage ratings may be exceeded if the input and output clamp current ratings are observed.

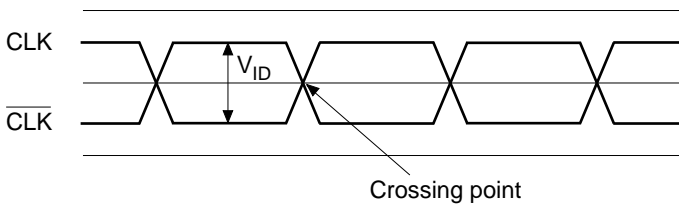
## Recommended Operating Conditions

Item	Symbol	Min	Typ	Max	Unit	Conditions
Supply voltage	$AV_{CC}$	2.3	2.5	2.7	V	
Output supply voltage	$V_{DDQ}$	2.3	2.5	2.7	V	
DC input signal voltage <sup>*1</sup>		-0.3	—	$V_{DDQ}+0.3$	V	All pins
High level input voltage	$V_{IHG}$	1.7	—	$V_{DDQ}+0.3$	V	$\overline{PWRDWN}$ input pin
Low level input voltage	$V_{ILG}$	-0.3	—	0.7	V	$\overline{PWRDWN}$ input pin
Differential input signal voltage	$V_{ID}$	0.36	—	$V_{DDQ}+0.6$	V	
Differential cross point voltage <sup>*2</sup>	$V_{IX}$ $V_{OX}$ <sup>*3</sup>	$0.5 \times V_{DDQ}$ -0.20	—	$0.5 \times V_{DDQ}$ +0.20	V	
Output current	$I_{OH}$	—	—	-12	mA	
	$I_{OL}$	—	—	12		
Input slew rate	SR	1	—	4	V/ns	20% – 80%
Operating temperature	$T_a$	0	—	70	°C	

Notes: Inputs pins must be prevent from floating.

Feedback inputs (FBIN,  $\overline{FBIN}$ ) may float when the device is in low power mode.

1. DC input signal voltage specifies the allowable dc execution of differential input.
2. Differential cross point voltage is expected to track variations of  $V_{DDQ}$  and is the voltage at which the differential signals must be crossing. (See figure1)
3. Guaranteed by design, not 100% tested in production.



**Figure 1 Differential input levels**

**Electrical Characteristics**

Item	Symbol	Min	Typ <sup>1</sup>	Max	Unit	Test Conditions
Input clamp voltage	CLK, $\overline{\text{CLK}}$ FBIN, $\overline{\text{FBIN}}$ , G	$V_{IK}$	—	—	–1.2	V $I_I = -18 \text{ mA}$ , $V_{DDQ} = 2.3 \text{ V}$
Output voltage	$V_{OH}$	$V_{DDQ} - 0.2$	—	—	—	$I_{OH} = -100 \mu\text{A}$ , $V_{DDQ} = 2.3 \text{ to } 2.7 \text{ V}$
		1.7	—	—	—	$I_{OH} = -12 \text{ mA}$ , $V_{DDQ} = 2.3 \text{ V}$
	$V_{OL}$	—	—	0.2	—	$I_{OL} = 100 \mu\text{A}$ , $V_{DDQ} = 2.3 \text{ to } 2.7 \text{ V}$
		—	—	0.6	—	$I_{OL} = 12 \text{ mA}$ , $V_{DDQ} = 2.3 \text{ V}$
Input current	$I_I$	—	—	$\pm 10$	$\mu\text{A}$ $V_I = 0 \text{ V to } 2.7 \text{ V}$ , $V_{DDQ} = 2.7 \text{ V}$	
Input capacitance	$C_I$	2.5	—	3.5	pF	CLK and $\overline{\text{CLK}}$ , FBIN and $\overline{\text{FBIN}}$
Delta input capacitance	$C_{DI}$	–0.25	—	0.25	pF	CLK and $\overline{\text{CLK}}$ , FBIN and $\overline{\text{FBIN}}$
Supply current	$DI_{CC}$	—	250	300	mA	$f = 170 \text{ MHz}$ , $V_{DDQ} = AV_{CC} = 2.7 \text{ V}$ ,
	$AI_{CC}$	—	9	12	—	All $Y_x$ , $\overline{Y_x}$ pin = open
Supply current in power down mode	$I_{CCpd}$	—	—	100	$\mu\text{A}$	

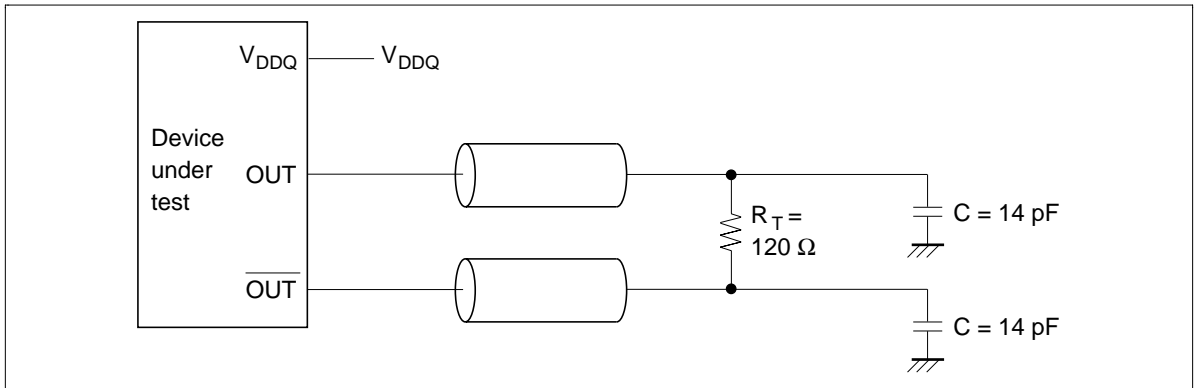
Note: 1. For conditions shown as Min or Max, use the appropriate value specified under recommended operating conditions.

**Switching Characteristics**

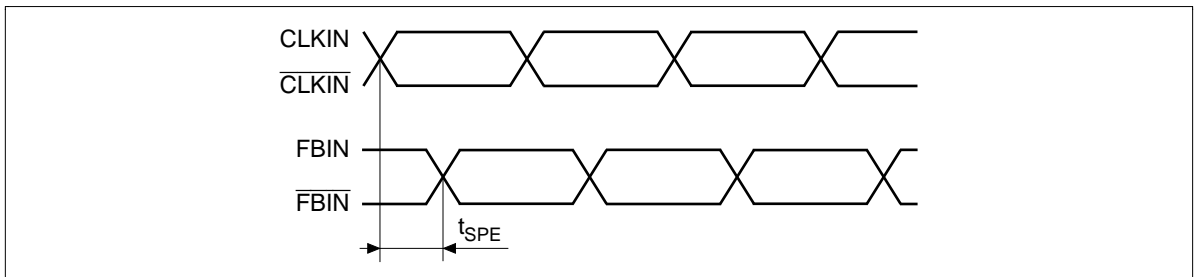
Item	Symbol	Min	Typ	Max	Unit	Test Conditions	Notes
Period jitter	$t_{PER}$	-75	—	75	ps	See figure 6, 9	7, 8
Half period jitter	$t_{HPER}$	-100	—	100	ps	See figure 7, 9	8, 10
Cycle to cycle jitter	$t_{CC}$	-75	—	75	ps	See figure 5, 9	10
Static phase offset	$t_{SPE}$	-75	—	75	ps	See figure 3, 9	4, 5, 9, 10
Output clock skew	$t_{sk}$	—	—	100	ps	See figure 4, 9	
Operating clock frequency	$f_{CLK(O)}$	60	—	200	MHz	See figure 9	1, 2
Application clock frequency	$f_{CLK(A)}$	95	133	170	MHz	See figure 9	1, 3
Slew rate	$t_{SL}$	1.0	—	2.0	V/ns	See figure 9	20% – 80%
PLL stabilization time	$t_{STAB}$	—	—	0.1	ms	See figure 9	6, 10

- Notes:
1. The PLL must be able to handle spread spectrum induced skew (the specification for this frequency modulation can be found in the latest Intel PC100 Registered DIMM specification)
  2. Operating clock frequency indicates a range over which the PLL must be able to lock, but in which it is not required to meet the other timing parameters.
  3. Application clock frequency indicates a range over which the PLL must meet all timing parameters.
  4. Assumes equal wire length and loading on the clock output and feedback path.
  5. Static phase offset does not include jitter.
  6. Stabilization time is the time required for the integrated PLL circuit to obtain phase lock of its feedback signal to its reference signal after power up.
  7. Period jitter defines the largest variation in clock period, around anominal clock period.
  8. Period jitter and half period jitter are independent from each other.
  9. Conditions at  $V_{DDQ} = 2.5\text{ V}$ ,  $T_a = 25^\circ\text{C}$ .
  10. Guaranteed by design, not 100% tested in production.

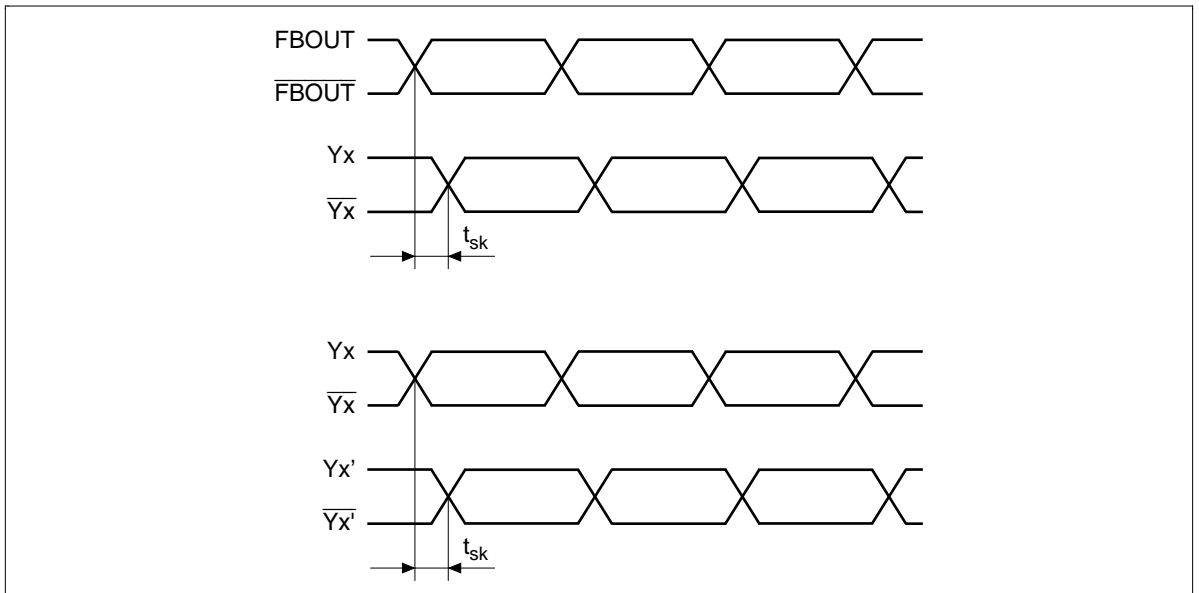
Differential clock outputs are directly terminated by a  $120\ \Omega$  resistor. Figure 2 is typical usage conditions of outputs load.



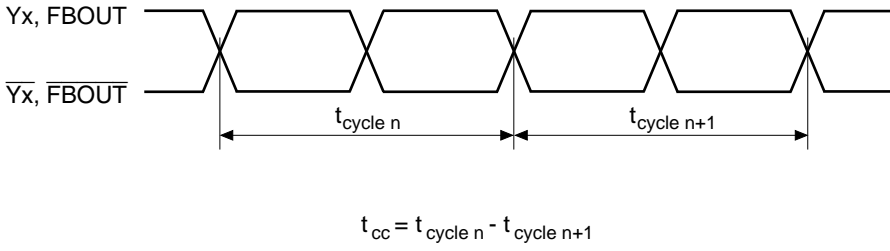
**Figure 2** Differential signal using direct termination resistor



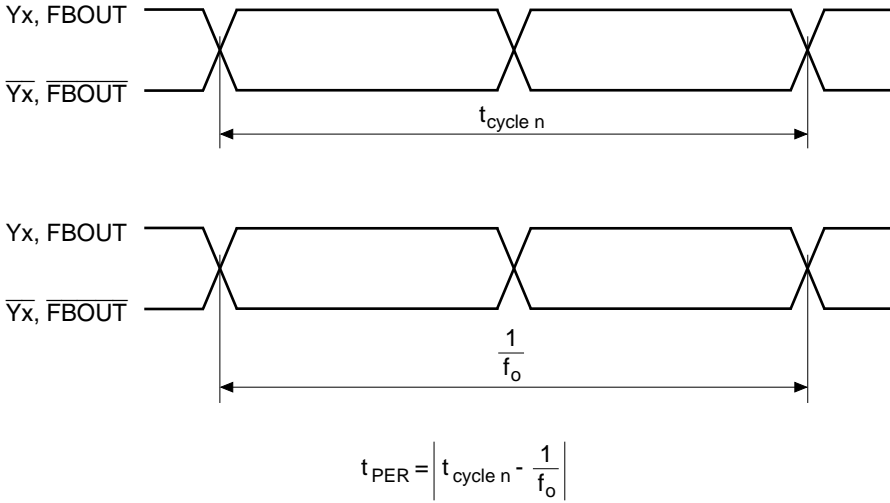
**Figure 3** Static phase offset



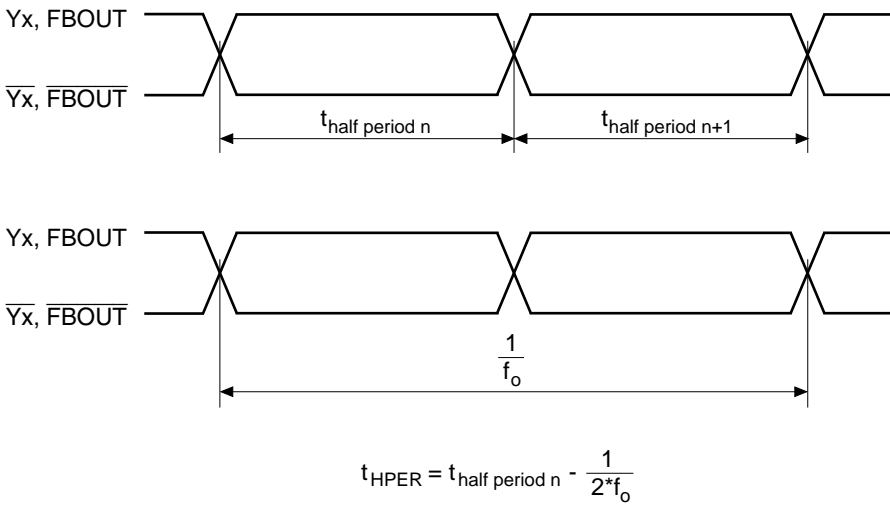
**Figure 4** Output skew



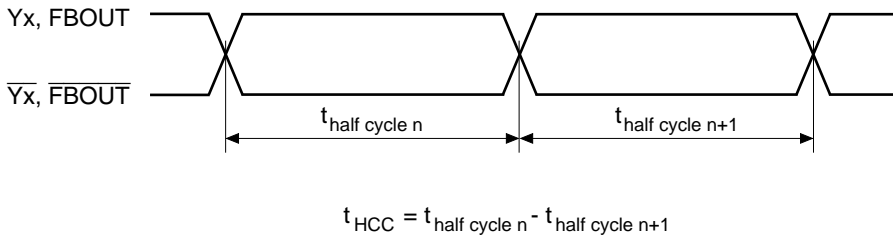
**Figure 5 Cycle to cycle jitter**



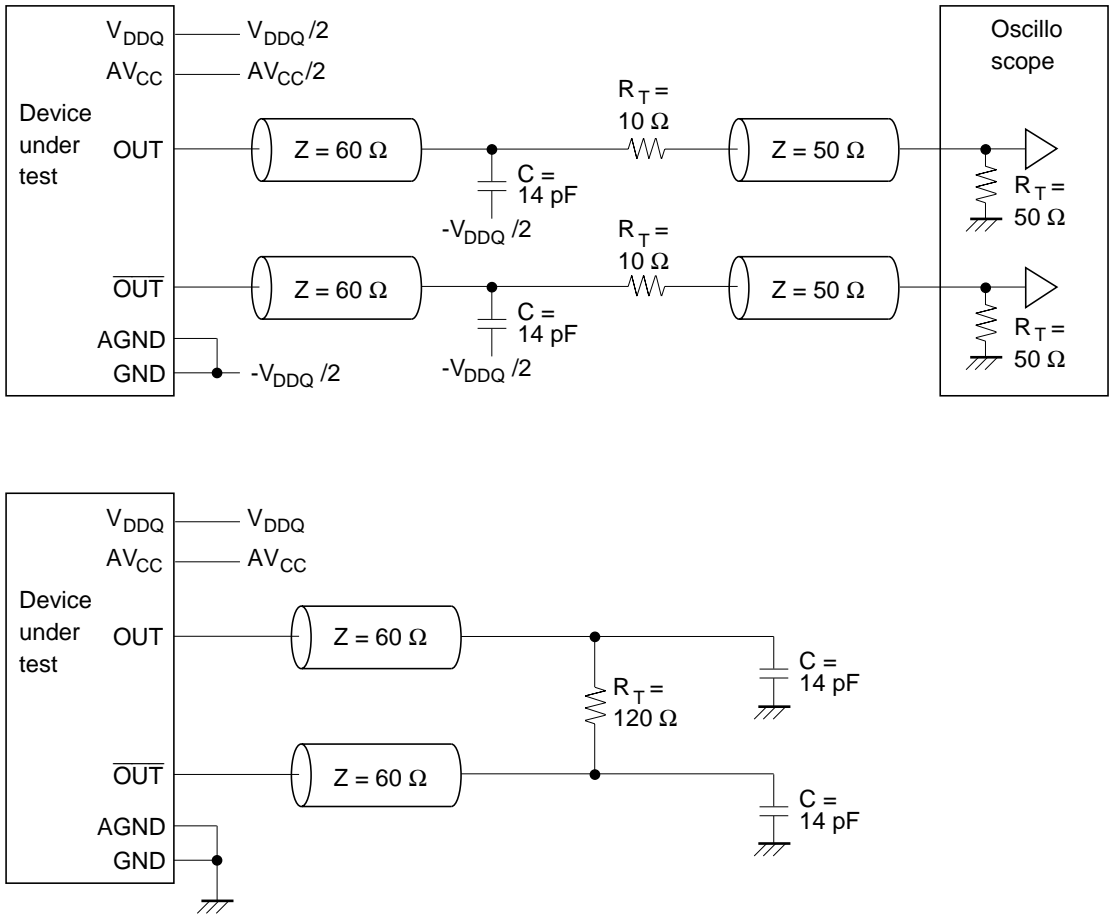
**Figure 6 Period jitter**



**Figure 7 Half period jitter**

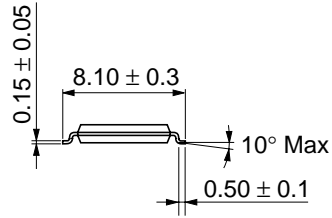
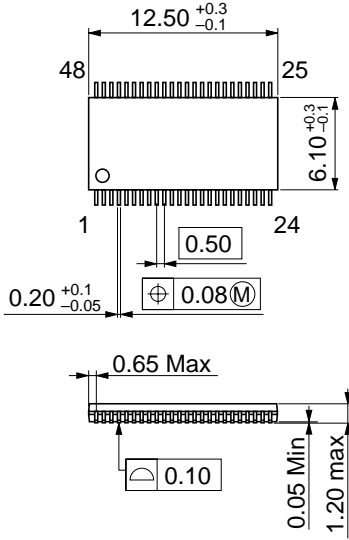


**Figure 8 Half cycle to cycle jitter**



## Package Dimensions

Unit : mm



Hitachi code	TTP-48DC
EIAJ code	—
JEDEC code	—

**Cautions**

1. Hitachi neither warrants nor grants licenses of any rights of Hitachi's or any third party's patent, copyright, trademark, or other intellectual property rights for information contained in this document. Hitachi bears no responsibility for problems that may arise with third party's rights, including intellectual property rights, in connection with use of the information contained in this document.
2. Products and product specifications may be subject to change without notice. Confirm that you have received the latest product standards or specifications before final design, purchase or use.
3. Hitachi makes every attempt to ensure that its products are of high quality and reliability. However, contact Hitachi's sales office before using the product in an application that demands especially high quality and reliability or where its failure or malfunction may directly threaten human life or cause risk of bodily injury, such as aerospace, aeronautics, nuclear power, combustion control, transportation, traffic, safety equipment or medical equipment for life support.
4. Design your application so that the product is used within the ranges guaranteed by Hitachi particularly for maximum rating, operating supply voltage range, heat radiation characteristics, installation conditions and other characteristics. Hitachi bears no responsibility for failure or damage when used beyond the guaranteed ranges. Even within the guaranteed ranges, consider normally foreseeable failure rates or failure modes in semiconductor devices and employ systemic measures such as fail-safes, so that the equipment incorporating Hitachi product does not cause bodily injury, fire or other consequential damage due to operation of the Hitachi product.
5. This product is not designed to be radiation resistant.
6. No one is permitted to reproduce or duplicate, in any form, the whole or part of this document without written approval from Hitachi.
7. Contact Hitachi's sales office for any questions regarding this document or Hitachi semiconductor products.

# HITACHI

**Hitachi, Ltd.**

Semiconductor & Integrated Circuits.  
 Nippon Bldg., 2-6-2, Ohte-machi, Chiyoda-ku, Tokyo 100-0004, Japan  
 Tel: Tokyo (03) 3270-2111 Fax: (03) 3270-5109

URL       NorthAmerica       : <http://semiconductor.hitachi.com/>  
           Europe                : <http://www.hitachi-eu.com/hel/ecg>  
           Asia                     : <http://sicapac.hitachi-asia.com>  
           Japan                    : <http://www.hitachi.co.jp/Sicd/indx.htm>

**For further information write to:**

Hitachi Semiconductor (America) Inc.  
 179 East Tasman Drive,  
 San Jose, CA 95134  
 Tel: <1> (408) 433-1990  
 Fax: <1> (408) 433-0223

Hitachi Europe Ltd.  
 Electronic Components Group.  
 Whitebrook Park  
 Lower Cookham Road  
 Maidenhead  
 Berkshire SL6 8YA, United Kingdom  
 Tel: <44> (1628) 585000  
 Fax: <44> (1628) 585200

Hitachi Europe GmbH  
 Electronic Components Group  
 Dornacher StraÙe 3  
 D-85622 Feldkirchen, Munich  
 Germany  
 Tel: <49> (89) 9 9180-0  
 Fax: <49> (89) 9 29 30 00

Hitachi Asia Ltd.  
 Hitachi Tower  
 16 Collyer Quay #20-00,  
 Singapore 049318  
 Tel : <65>-538-6533/538-8577  
 Fax : <65>-538-6933/538-3877  
 URL : <http://www.hitachi.com.sg>

Hitachi Asia Ltd.  
 (Taipei Branch Office)  
 4/F, No. 167, Tun Hwa North Road,  
 Hung-Kuo Building,  
 Taipei (105), Taiwan  
 Tel : <886>-(2)-2718-3666  
 Fax : <886>-(2)-2718-8180  
 Telex : 23222 HAS-TP  
 URL : <http://www.hitachi.com.tw>

Hitachi Asia (Hong Kong) Ltd.  
 Group III (Electronic Components)  
 7/F., North Tower,  
 World Finance Centre,  
 Harbour City, Canton Road  
 Tsim Sha Tsui, Kowloon,  
 Hong Kong  
 Tel : <852>-(2)-735-9218  
 Fax : <852>-(2)-730-0281  
 URL : <http://semiconductor.hitachi.com.hk>

Copyright © Hitachi, Ltd., 2001. All rights reserved. Printed in Japan.

Colophon 3.0