

---

# HM6264B Series

64 k SRAM (8-kword × 8-bit)

# HITACHI

ADE-203-454B (Z)

Rev. 2.0

Nov. 1997

---

## Description

The Hitachi HM6264B is 64k-bit static RAM organized 8-kword × 8-bit. It realizes higher performance and low power consumption by 1.5 μm CMOS process technology. The device, packaged in 450 mil SOP (foot print pitch width), 600 mil plastic DIP, 300 mil plastic DIP, is available for high density mounting.

## Features

- High speed  
Fast access time: 85/100 ns (max)
- Low power  
Standby: 10 μW (typ)  
Operation: 15 mW (typ) (f = 1 MHz)
- Single 5 V supply
- Completely static memory  
No clock or timing strobe required
- Equal access and cycle times
- Common data input and output  
Three state output
- Directly TTL compatible  
All inputs and outputs
- Battery backup operation capability

# HM6264B Series

## Ordering Information

Type No.	Access time	Package
HM6264BLP-8L	85 ns	600-mil, 28-pin plastic DIP (DP-28)
HM6264BLP-10L	100 ns	
HM6264BLSP-8L	85 ns	300-mil, 28-pin plastic DIP(DP-28N)
HM6264BLSP-10L	100 ns	
HM6264BLFP-8LT	85 ns	450-mil, 28-pin plastic SOP(FP-28DA)
HM6264BLFP-10LT	100 ns	

## Pin Arrangement

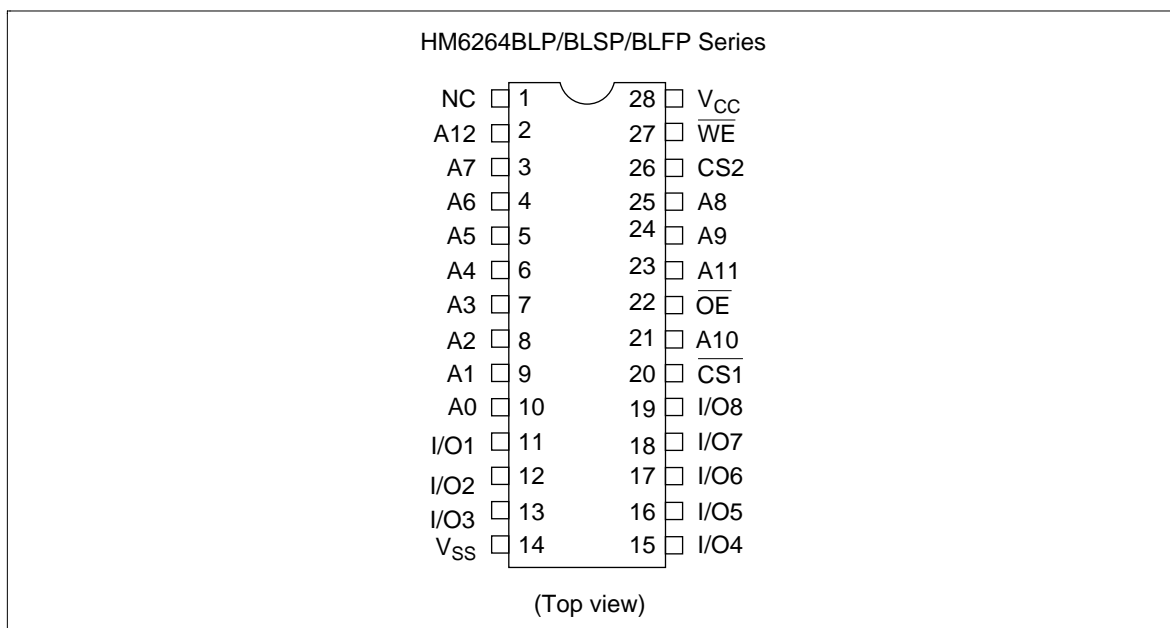

## Pin Description

Pin name	Function	Pin name	Function
A0 to A12	Address input	$\overline{WE}$	Write enable
I/O1 to I/O8	Data input/output	$\overline{OE}$	Output enable
$\overline{CS1}$	Chip select 1	NC	No connection
CS2	Chip select 2	$V_{CC}$	Power supply
		$V_{SS}$	Ground

Block Diagram

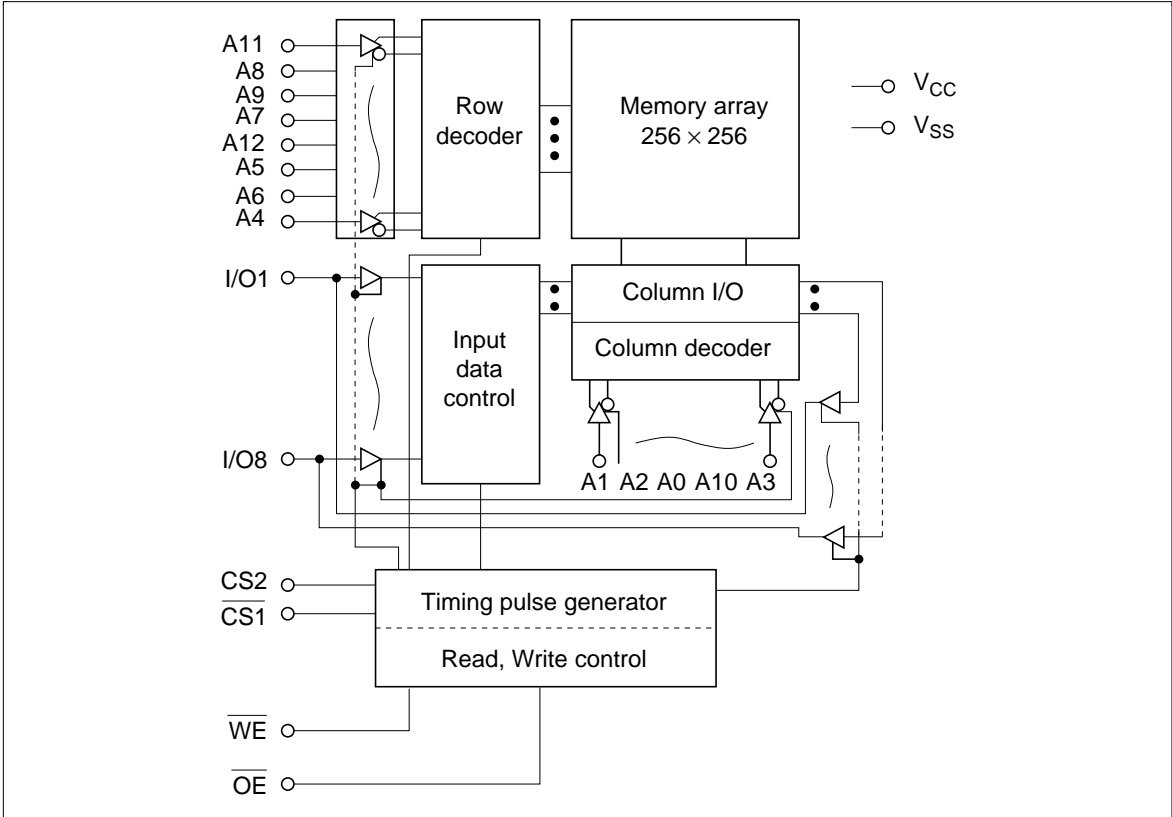

# HM6264B Series

## Function Table

$\overline{WE}$	$\overline{CS1}$	$CS2$	$\overline{OE}$	Mode	$V_{CC}$ current	I/O pin	Ref. cycle
×	H	×	×	Not selected (power down)	$I_{SB}, I_{SB1}$	High-Z	—
×	×	L	×	Not selected (power down)	$I_{SB}, I_{SB1}$	High-Z	—
H	L	H	H	Output disable	$I_{CC}$	High-Z	—
H	L	H	L	Read	$I_{CC}$	Dout	Read cycle (1)–(3)
L	L	H	H	Write	$I_{CC}$	Din	Write cycle (1)
L	L	H	L	Write	$I_{CC}$	Din	Write cycle (2)

Note: ×: H or L

## Absolute Maximum Ratings

Parameter	Symbol	Value	Unit
Power supply voltage <sup>1</sup>	$V_{CC}$	−0.5 to +7.0	V
Terminal voltage <sup>1</sup>	$V_T$	−0.5 <sup>2</sup> to $V_{CC} + 0.3$ <sup>3</sup>	V
Power dissipation	$P_T$	1.0	W
Operating temperature	Topr	0 to +70	°C
Storage temperature	Tstg	−55 to +125	°C
Storage temperature under bias	Tbias	−10 to +85	°C

Notes: 1. Relative to  $V_{SS}$

2.  $V_T$  min: −3.0 V for pulse half-width ≤ 50 ns

3. Maximum voltage is 7.0 V

## Recommended DC Operating Conditions (Ta = 0 to +70°C)

Parameter	Symbol	Min	Typ	Max	Unit
Supply voltage	$V_{CC}$	4.5	5.0	5.5	V
	$V_{SS}$	0	0	0	V
Input high voltage	$V_{IH}$	2.2	—	$V_{CC} + 0.3$	V
Input low voltage	$V_{IL}$	−0.3 <sup>1</sup>	—	0.8	V

Note: 1.  $V_{IL}$  min: −3.0 V for pulse half-width ≤ 50 ns

**DC Characteristics** ( $T_a = 0$  to  $+70^\circ\text{C}$ ,  $V_{CC} = 5\text{ V} \pm 10\%$ ,  $V_{SS} = 0\text{ V}$ )

Parameter	Symbol	Min	Typ <sup>1</sup>	Max	Unit	Test conditions
Input leakage current	$ I_{LI} $	—	—	2	$\mu\text{A}$	$V_{in} = V_{SS}$ to $V_{CC}$
Output leakage current	$ I_{LO} $	—	—	2	$\mu\text{A}$	$\overline{CS1} = V_{IH}$ or $CS2 = V_{IL}$ or $\overline{OE} = V_{IH}$ or $\overline{WE} = V_{IL}$ , $V_{IO} = V_{SS}$ to $V_{CC}$
Operating power supply current	$I_{CCDC}$	—	7	15	mA	$\overline{CS1} = V_{IL}$ , $CS2 = V_{IH}$ , $I_{IO} = 0\text{ mA}$ others = $V_{IH}/V_{IL}$
Average operating power supply current	$I_{CC1}$	—	30	45	mA	Min cycle, duty = 100%, $\overline{CS1} = V_{IL}$ , $CS2 = V_{IH}$ , $I_{IO} = 0\text{ mA}$ others = $V_{IH}/V_{IL}$
	$I_{CC2}$	—	3	5	mA	Cycle time = 1 $\mu\text{s}$ , duty = 100%, $I_{IO} = 0\text{ mA}$ $\overline{CS1} \leq 0.2\text{ V}$ , $CS2 \geq V_{CC} - 0.2\text{ V}$ , $V_{IH} \geq V_{CC} - 0.2\text{ V}$ , $V_{IL} \leq 0.2\text{ V}$
Standby power supply current	$I_{SB}$	—	1	3	mA	$\overline{CS1} = V_{IH}$ , $CS2 = V_{IL}$
	$I_{SB1}$	—	2	50	$\mu\text{A}$	$\overline{CS1} \geq V_{CC} - 0.2\text{ V}$ , $CS2 \geq V_{CC} - 0.2\text{ V}$ or $0\text{ V} \leq CS2 \leq 0.2\text{ V}$ , $0\text{ V} \leq V_{in}$
Output low voltage	$V_{OL}$	—	—	0.4	V	$I_{OL} = 2.1\text{ mA}$
Output high voltage	$V_{OH}$	2.4	—	—	V	$I_{OH} = -1.0\text{ mA}$

Notes: 1. Typical values are at  $V_{CC} = 5.0\text{ V}$ ,  $T_a = +25^\circ\text{C}$  and not guaranteed.

**Capacitance** ( $T_a = 25^\circ\text{C}$ ,  $f = 1.0\text{ MHz}$ )

Parameter	Symbol	Min	Typ	Max	Unit	Test conditions
Input capacitance <sup>1</sup>	$C_{in}$	—	—	5	pF	$V_{in} = 0\text{ V}$
Input/output capacitance <sup>1</sup>	$C_{IO}$	—	—	7	pF	$V_{IO} = 0\text{ V}$

Note: 1. This parameter is sampled and not 100% tested.

# HM6264B Series

**AC Characteristics** ( $T_a = 0$  to  $+70^\circ\text{C}$ ,  $V_{CC} = 5\text{ V} \pm 10\%$ , unless otherwise noted.)

## Test Conditions

- Input pulse levels: 0.8 V to 2.4 V
- Input and output timing reference level: 1.5 V
- Input rise and fall time: 10 ns
- Output load: 1 TTL Gate +  $C_L$  (100 pF) (Including scope & jig)

## Read Cycle

Parameter	Symbol	HM6264B-8L		HM6264B-10L		Unit	Notes
		Min	Max	Min	Max		
Read cycle time	$t_{RC}$	85	—	100	—	ns	
Address access time	$t_{AA}$	—	85	—	100	ns	
Chip select access time	$\overline{CS1}$ $t_{CO1}$	—	85	—	100	ns	
	CS2 $t_{CO2}$	—	85	—	100	ns	
Output enable to output valid	$t_{OE}$	—	45	—	50	ns	
Chip selection to output in low-Z	$\overline{CS1}$ $t_{LZ1}$	10	—	10	—	ns	2
	CS2 $t_{LZ2}$	10	—	10	—	ns	2
Output enable to output in low-Z	$t_{OLZ}$	5	—	5	—	ns	2
Chip deselection in to output in high-Z	$\overline{CS1}$ $t_{HZ1}$	0	30	0	35	ns	1, 2
	CS2 $t_{HZ2}$	0	30	0	35	ns	1, 2
Output disable to output in high-Z	$t_{OHZ}$	0	30	0	35	ns	1, 2
Output hold from address change	$t_{OH}$	10	—	10	—	ns	

Notes: 1.  $t_{HZ}$  is defined as the time at which the outputs achieve the open circuit conditions and are not referred to output voltage levels.

2. At any given temperature and voltage condition,  $t_{HZ}$  maximum is less than  $t_{LZ}$  minimum both for a given device and from device to device.

Read Timing Waveform (1) ( $\overline{WE} = V_{IH}$ )

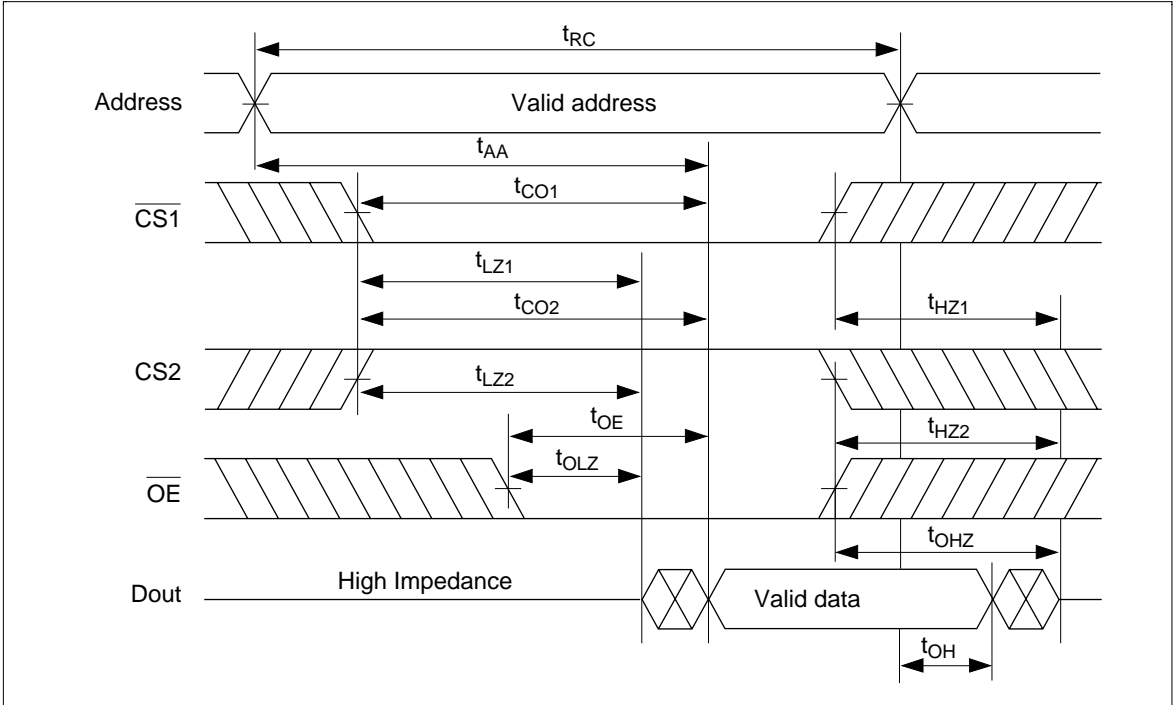

Read Timing Waveform (2) ( $\overline{WE} = V_{IH}, \overline{OE} = V_{IL}$ )

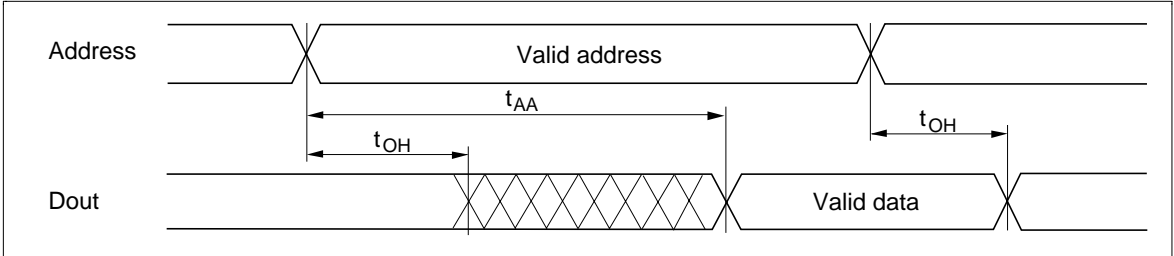

# HM6264B Series

## Read Timing Waveform (3) ( $\overline{WE} = V_{IH}, \overline{OE} = V_{IL}$ )\*<sup>1</sup>

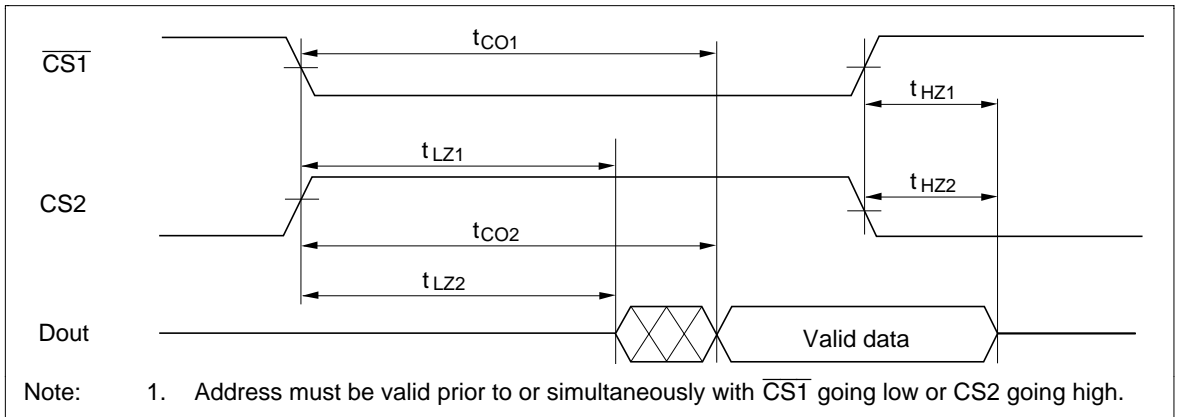

## Write Cycle

Parameter	Symbol	HM6264B-8L		HM6264B-10L		Unit	Notes
		Min	Max	Min	Max		
Write cycle time	$t_{WC}$	85	—	100	—	ns	
Chip selection to end of write	$t_{CW}$	75	—	80	—	ns	2
Address setup time	$t_{AS}$	0	—	0	—	ns	3
Address valid to end of write	$t_{AW}$	75	—	80	—	ns	
Write pulse width	$t_{WP}$	55	—	60	—	ns	1, 6
Write recovery time	$t_{WR}$	0	—	0	—	ns	4
$\overline{WE}$ to output in high-Z	$t_{WHZ}$	0	30	0	35	ns	5
Data to write time overlap	$t_{DW}$	40	—	40	—	ns	
Data hold from write time	$t_{DH}$	0	—	0	—	ns	
Output active from end of write	$t_{OW}$	5	—	5	—	ns	
Output disable to output in high-Z	$t_{OHZ}$	0	30	0	35	ns	5

- Notes:
1. A write occurs during the overlap of a low  $\overline{CS1}$ , and high CS2, and a high  $\overline{WE}$ . A write begins at the latest transition among  $\overline{CS1}$  going low, CS2 going high and  $\overline{WE}$  going low. A write ends at the earliest transition among  $\overline{CS1}$  going high CS2 going low and  $\overline{WE}$  going high. Time  $t_{WP}$  is measured from the beginning of write to the end of write.
  2.  $t_{CW}$  is measured from the later of  $\overline{CS1}$  going low or CS2 going high to the end of write.
  3.  $t_{AS}$  is measured from the address valid to the beginning of write.
  4.  $t_{WR}$  is measured from the earliest of  $\overline{CS1}$  or  $\overline{WE}$  going high or CS2 going low to the end of write cycle.
  5. During this period, I/O pins are in the output state, therefore the input signals of the opposite phase to the outputs must not be applied.
  6. In the write cycle with  $\overline{OE}$  low fixed,  $t_{WP}$  must satisfy the following equation to avoid a problem of data bus contention  

$$t_{WP} \geq t_{WHZ} \text{ max} + t_{DW} \text{ min.}$$

# HM6264B Series

## Write Timing Waveform (1) ( $\overline{\text{OE}}$ Clock)

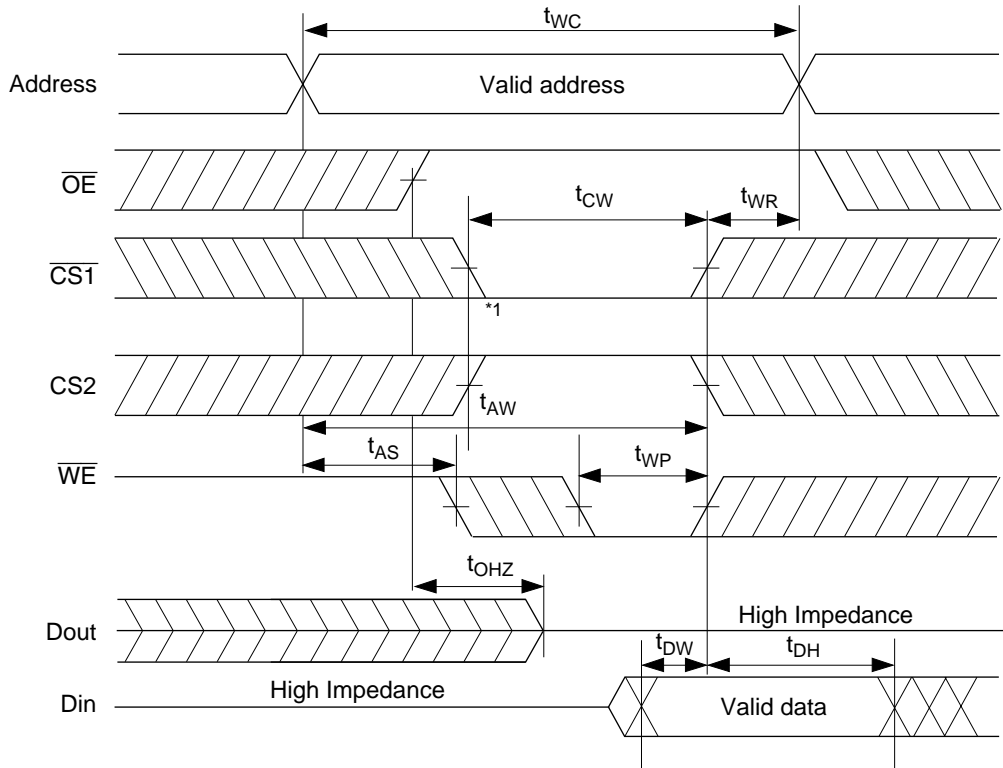

Note: 1. If  $\overline{\text{CS1}}$  goes low or CS2 goes high simultaneously with  $\overline{\text{WE}}$  going low or after  $\overline{\text{WE}}$  going low, the outputs remain in the high impedance state.

Write Timing Waveform (2) ( $\overline{OE}$  Low Fixed) ( $\overline{OE} = V_{IL}$ )

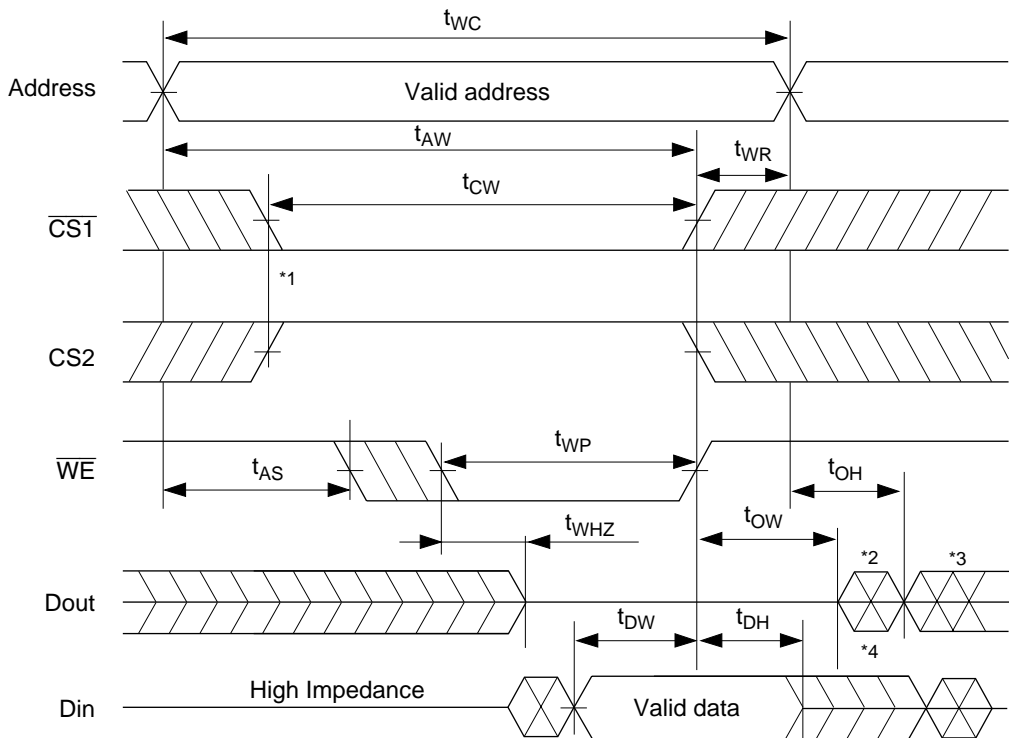

- Notes:
1. If  $\overline{CS1}$  goes low simultaneously with  $\overline{WE}$  going low or after  $\overline{WE}$  goes low, the outputs remain in high impedance state.
  2. Dout is the same phase of the written data in this write cycle.
  3. Dout is the read data of the next address.
  4. If  $\overline{CS1}$  is low and CS2 is high during this period, I/O pins are in the output state. Input signals of opposite phase to the outputs must not be applied to I/O pins.

## Low $V_{CC}$ Data Retention Characteristics ( $T_a = 0$ to $+70^\circ\text{C}$ )

Parameter	Symbol	Min	Typ <sup>1</sup>	Max	Unit	Test conditions <sup>4</sup>
$V_{CC}$ for data retention	$V_{DR}$	2.0	—	—	V	$\overline{CS1} \geq V_{CC} - 0.2 \text{ V}$ , $CS2 \geq V_{CC} - 0.2 \text{ V}$ or $CS2 \leq 0.2 \text{ V}$
Data retention current	$I_{CCDR}$	—	1 <sup>1</sup>	25 <sup>2</sup>	$\mu\text{A}$	$V_{CC} = 3.0 \text{ V}$ , $0 \text{ V} \leq V_{in} \leq V_{CC}$ $\overline{CS1} \geq V_{CC} - 0.2 \text{ V}$ , $CS2 \geq V_{CC} - 0.2 \text{ V}$ or $0 \text{ V} \leq CS2 \leq 0.2 \text{ V}$
Chip deselect to data retention time	$t_{CDR}$	0	—	—	ns	See retention waveform
Operation recovery time	$t_R$	$t_{RC}$ <sup>3</sup>	—	—	ns	

- Notes:
- Reference data at  $T_a = 25^\circ\text{C}$ .
  - 10  $\mu\text{A}$  max at  $T_a = 0$  to  $+40^\circ\text{C}$ .
  - $t_{RC}$  = read cycle time.
  - $CS2$  controls address buffer,  $\overline{WE}$  buffer,  $\overline{CS1}$  buffer,  $\overline{OE}$  buffer, and  $Din$  buffer. If  $CS2$  controls data retention mode,  $V_{in}$  levels (address,  $\overline{WE}$ ,  $\overline{OE}$ ,  $\overline{CS1}$ , I/O) can be in the high impedance state. If  $\overline{CS1}$  controls data retention mode,  $CS2$  must be  $CS2 \geq V_{CC} - 0.2 \text{ V}$  or  $0 \text{ V} \leq CS2 \leq 0.2 \text{ V}$ . The other input levels (address,  $\overline{WE}$ ,  $\overline{OE}$ , I/O) can be in the high impedance state.

### Low $V_{CC}$ Data Retention Timing Waveform (1) ( $\overline{CS1}$ Controlled)

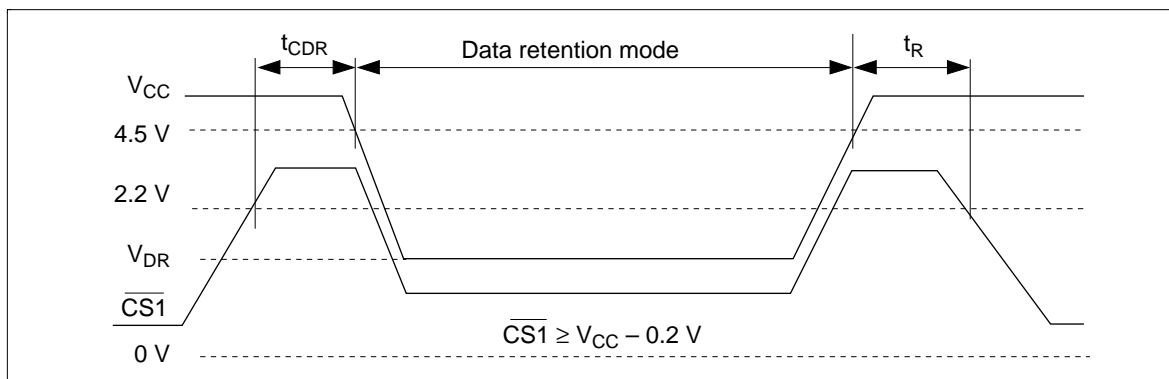

### Low $V_{CC}$ Data Retention Timing Waveform (2) ( $CS2$ Controlled)

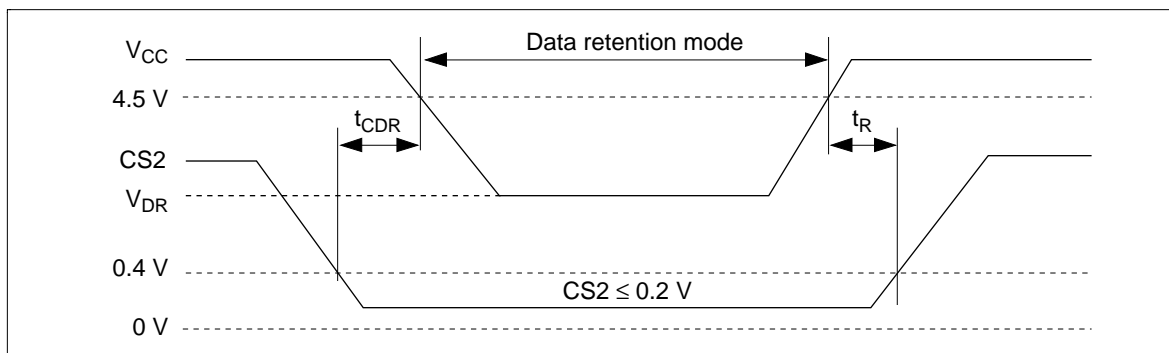

Package Dimensions

HM6264BLP Series (DP-28)

Unit: mm

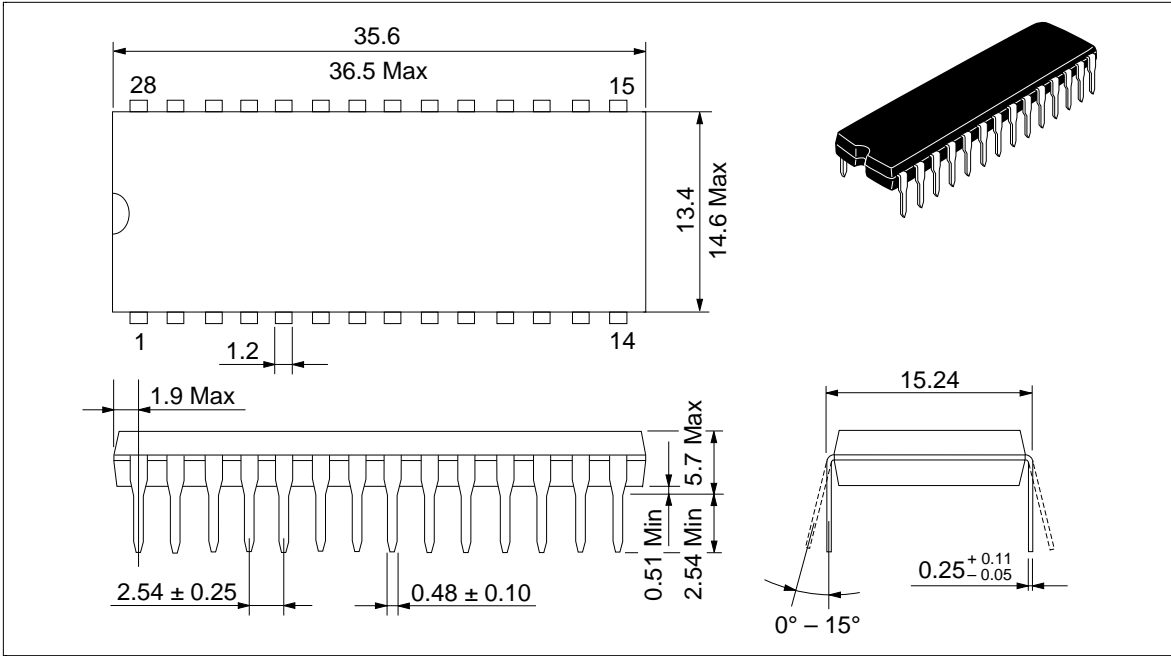

# HM6264B Series

## HM6264BLSP Series (DP-28N)

Unit: mm

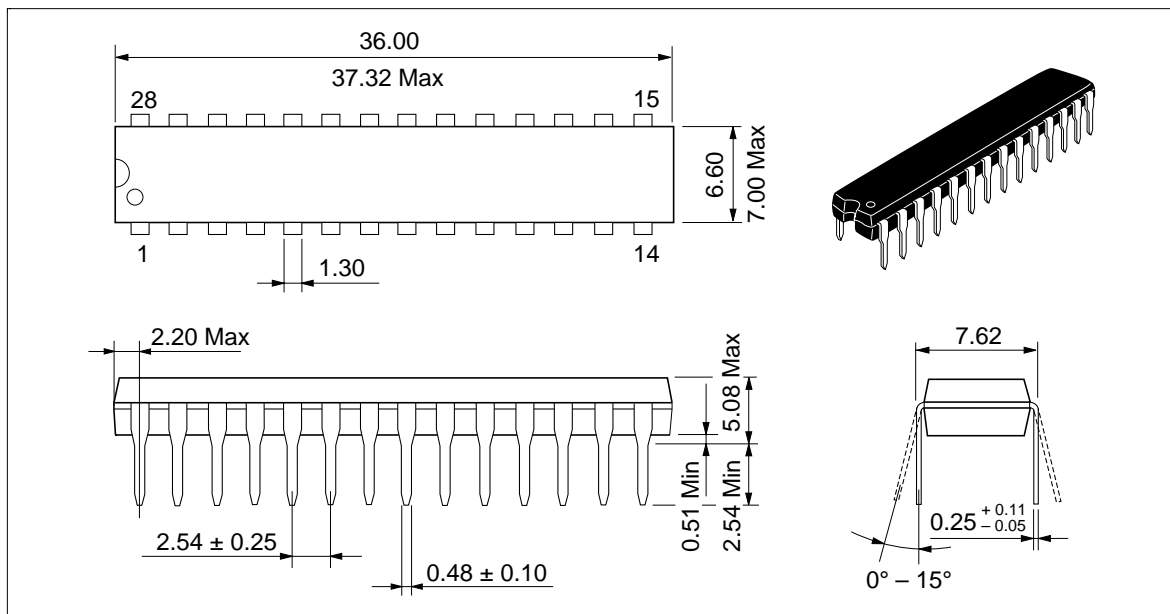

## HM6264BLTM Series (FP-28DA)

Unit: mm

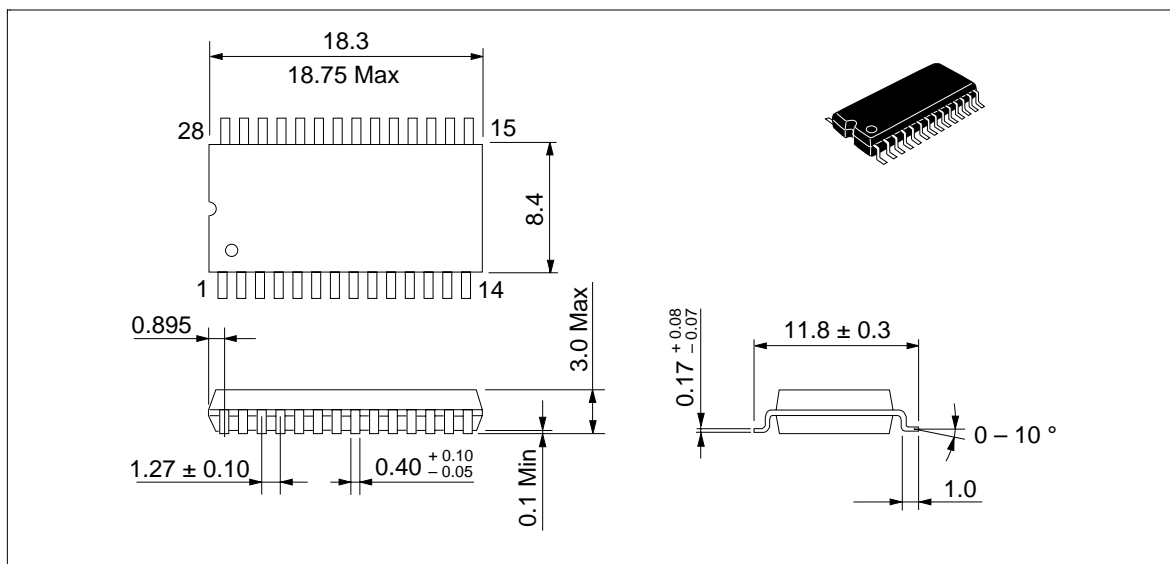

When using this document, keep the following in mind:

1. This document may, wholly or partially, be subject to change without notice.
2. All rights are reserved: No one is permitted to reproduce or duplicate, in any form, the whole or part of this document without Hitachi's permission.
3. Hitachi will not be held responsible for any damage to the user that may result from accidents or any other reasons during operation of the user's unit according to this document.
4. Circuitry and other examples described herein are meant merely to indicate the characteristics and performance of Hitachi's semiconductor products. Hitachi assumes no responsibility for any intellectual property claims or other problems that may result from applications based on the examples described herein.
5. No license is granted by implication or otherwise under any patents or other rights of any third party or Hitachi, Ltd.
6. **MEDICAL APPLICATIONS:** Hitachi's products are not authorized for use in **MEDICAL APPLICATIONS** without the written consent of the appropriate officer of Hitachi's sales company. Such use includes, but is not limited to, use in life support systems. Buyers of Hitachi's products are requested to notify the relevant Hitachi sales offices when planning to use the products in **MEDICAL APPLICATIONS**.

---

---

# HITACHI

## **Hitachi, Ltd.**

Semiconductor & IC Div.  
Nippon Bldg., 2-6-2, Ohte-machi, Chiyoda-ku, Tokyo 100, Japan  
Tel: Tokyo (03) 3270-2111  
Fax: (03) 3270-5109

### **For further information write to:**

Hitachi America, Ltd.  
Semiconductor & IC Div.  
2000 Sierra Point Parkway  
Brisbane, CA. 94005-1835  
U S A  
Tel: 415-589-8300  
Fax: 415-583-4207

Hitachi Europe GmbH  
Electronic Components Group  
Continental Europe  
Dornacher Straße 3  
D-85622 Feldkirchen  
München  
Tel: 089-9 91 80-0  
Fax: 089-9 29 30 00

Hitachi Europe Ltd.  
Electronic Components Div.  
Northern Europe Headquarters  
Whitebrook Park  
Lower Cookham Road  
Maidenhead  
Berkshire SL6 8YA  
United Kingdom  
Tel: 0628-585000  
Fax: 0628-778322

Hitachi Asia Pte. Ltd.  
16 Collyer Quay #20-00  
Hitachi Tower  
Singapore 0104  
Tel: 535-2100  
Fax: 535-1533

Hitachi Asia (Hong Kong) Ltd.  
Unit 706, North Tower,  
World Finance Centre,  
Harbour City, Canton Road  
Tsim Sha Tsui, Kowloon  
Hong Kong  
Tel: 27359218  
Fax: 27306071