

November 2003

## Features

- Supports AT&T TR62411 and Bellcore GR-1244-CORE Stratum 4 Enhanced and Stratum 4 timing for DS1 Interfaces
- Supports ETSI ETS 300 011, TBR 4, TBR 12 and TBR 13 timing for E1 Interfaces
- Selectable 1.544MHz, 2.048MHz or 8kHz input reference signals
- Provides C1.5, C2,  $\overline{C3}$ ,  $\overline{C4}$ , C8 and  $\overline{C16}$  output clock signals
- Provides 3 different styles of 8 KHz framing pulses
- Attenuates wander from 1.9 Hz

## Applications

- Synchronization and timing control for multitruunk T1 and E1 systems
- ST-BUS clock and frame pulse sources

### Ordering Information

MT9041BP 28 Pin PLCC

-40°C to +85°C

## Description

The MT9041B T1/E1 System Synchronizer contains a digital phase-locked loop (DPLL), which provides timing and synchronization signals for multitruunk T1 and E1 primary rate transmission links.

The MT9041B generates ST-BUS clock and framing signals that are phase locked to either a 2.048MHz, 1.544MHz, or 8kHz input reference.

The MT9041B is compliant with AT&T TR62411 and Bellcore GR-1244-CORE Stratum 4 Enhanced, Stratum 4, and ETSI ETS 300 011. It will meet the jitter tolerance, jitter transfer, intrinsic jitter, frequency accuracy, capture range and phase change slope requirements for these specifications.

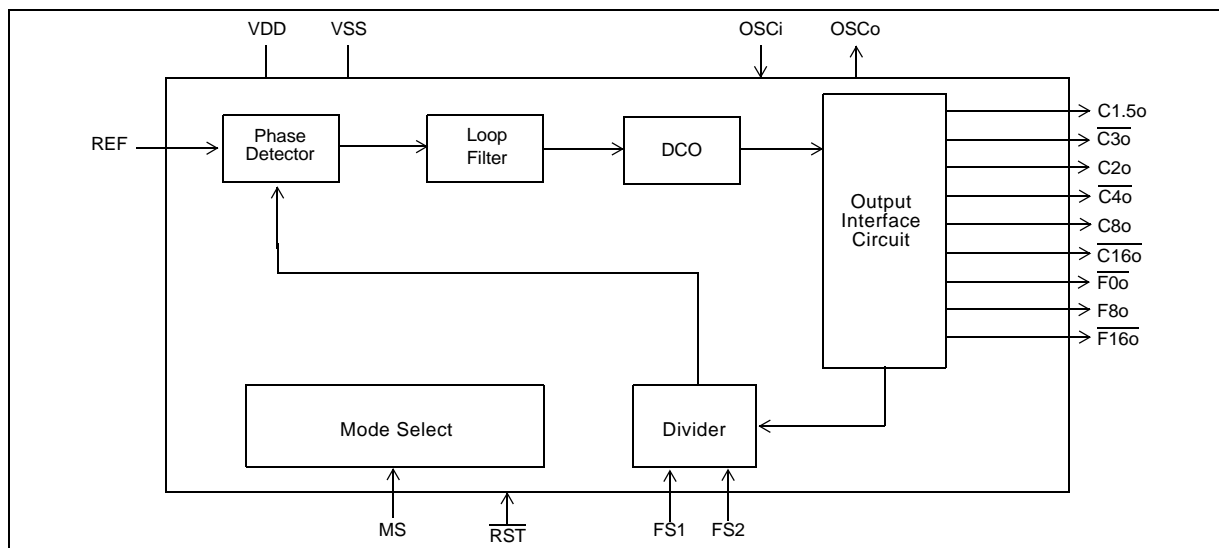

Figure 1 - Functional Block Diagram

Zarlink Semiconductor US Patent No. 5,602,884, UK Patent No. 0772912,  
 France Brevete S.G.D.G. 0772912; Germany DBP No. 69502724.7-08

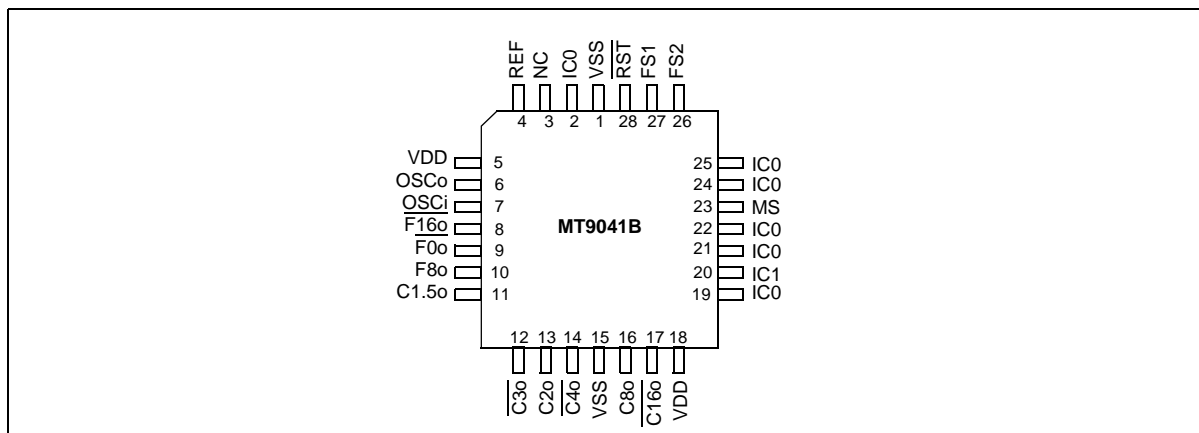

Figure 2 - Pin Connections

## Pin Description

Pin #	Name	Description
1	V <sub>SS</sub>	<b>Ground.</b> 0 Volts.
2	IC0	<b>Internal Connect.</b> Connect to Vss
3	NC	<b>No Connect.</b> Connect to Vss
4	REF	<b>Reference (TTL Input).</b> PLL reference clock.
5	V <sub>DD</sub>	<b>Positive Supply Voltage.</b> +5V <sub>DC</sub> nominal.
6	OSCo	<b>Oscillator Master Clock (CMOS Output).</b> For crystal operation, a 20MHz crystal is connected from this pin to OSCi, see Figure 6. For clock oscillator operation, this pin is left unconnected, see Figure 5.
7	OSCi	<b>Oscillator Master Clock (CMOS Input).</b> For crystal operation, a 20MHz crystal is connected from this pin to OSCo, see Figure 6. For clock oscillator operation, this pin is connected to a clock source, see Figure 5.
8	F16o	<b>Frame Pulse ST-BUS 16.384Mb/s (CMOS Output).</b> This is an 8kHz 61ns active low framing pulse, which marks the beginning of an ST-BUS frame. This is typically used for ST-BUS operation at 16.384Mb/s. See Figure 11.
9	F0o	<b>Frame Pulse ST-BUS 2.048Mb/s (CMOS Output).</b> This is an 8kHz 244ns active low framing pulse, which marks the beginning of an ST-BUS frame. This is typically used for ST-BUS operation at 2.048Mb/s and 4.096Mb/s. See Figure 11.
10	F8o	<b>Frame Pulse ST-BUS 8.192Mb/s (CMOS Output).</b> This is an 8kHz 122ns active high framing pulse, which marks the beginning of an ST-BUS frame. This is used for ST-BUS operation at 8.192Mb/s. See Figure 11.
11	C1.5o	<b>Clock 1.544MHz (CMOS Output).</b> This output is used in T1 applications.
12	C3o	<b>Clock 3.088MHz (CMOS Output).</b> This optional output is used in T1 applications.
13	C2o	<b>Clock 2.048MHz (CMOS Output).</b> This output is used for ST-BUS operation at 2.048Mb/s.
14	C4o	<b>Clock 4.096MHz (CMOS Output).</b> This output is used for ST-BUS operation at 2.048Mb/s and 4.096Mb/s.

**Pin Description (continued)**

Pin #	Name	Description
15	V <sub>SS</sub>	<b>Ground.</b> 0 Volts.
16	C8o	<b>Clock 8.192MHz (CMOS Output).</b> This output is used for ST-BUS operation at 8.192Mb/s.
17	$\overline{C16o}$	<b>Clock 16.384MHz (CMOS Output).</b> This output is used for ST-BUS operation at 16.384Mb/s.
18	V <sub>DD</sub>	<b>Positive Supply Voltage.</b> +5V <sub>DC</sub> nominal.
19	IC0	<b>Internal Connect.</b> Connect to Vss
20	IC1	<b>Internal Connect.</b> Leave open Circuit
21	IC0	<b>Internal Connect.</b> Connect to Vss
22	IC0	<b>Internal Connect.</b> Connect to Vss
23	MS	<b>Mode/Control Select (TTL Input).</b> This pin, determines the device's state (Normal, or Freerun) of operation. The logic level at this input is gated in by the rising edge of F8o. See Table 3.
24	IC0	<b>Internal Connect.</b> Connect to Vss
25	IC0	<b>Internal Connect.</b> Connect to Vss
26	FS2	<b>Frequency Select 2 (TTL Input).</b> This input, in conjunction with FS1, selects which of three possible frequencies (8kHz, 1.544MHz, or 2.048MHz) may be input to the REF input. See Table 1.
27	FS1	<b>Frequency Select 1 (TTL Input).</b> See pin description for FS2.
28	$\overline{RST}$	<b>Reset (Schmitt Input).</b> A logic low at this input resets the MT9041B. To ensure proper operation, the device must be reset after reference signal frequency changes and power-up. The RST pin should be held low for a minimum of 300ns. While the RST pin is low, all frame and clock outputs are at logic high. Following a reset, the input reference source and output clocks and frame pulses are phase aligned as shown in Figure 10.

**Functional Description**

The MT9041B is a System Synchronizer, providing timing (clock) and synchronization (frame) signals to interface circuits for T1 and E1 Primary Rate Digital Transmission links.

Figure 1 is a functional block diagram which is described in the following sections.

**Frequency Select MUX Circuit**

The MT9041B operates on the falling edges of one of three possible input reference frequencies (8kHz, 1.544MHz or 2.048MHz). The frequency select inputs (FS1 and FS2) determine which of the three frequencies may be used at the reference input (REF). A reset ( $\overline{RST}$ ) must be performed after every frequency select input change. Operation with FS1 and FS2 both at logic low is reserved and must not be used. See Table 1.

FS2	FS1	Input Frequency
0	0	Reserved
0	1	8kHz
1	0	1.544MHz
1	1	2.048MHz

**Table 1 - Input Frequency Selection**

### Digital Phase Lock Loop (DPLL)

The DPLL of the MT9041B consists of a Phase Detector, Limiter, Loop Filter, Digitally Controlled Oscillator, and a Control Circuit (see Figure 3).

**Phase Detector** - the Phase Detector compares the primary reference signal (REF) with the feedback signal from the Frequency Select MUX circuit, and provides an error signal corresponding to the phase difference between the two. This error signal is passed to the Limiter circuit. The Frequency Select MUX allows the proper feedback signal to be externally selected (e.g., 8kHz, 1.544MHz or 2.048MHz).

**Limiter** - the Limiter receives the error signal from the Phase Detector and ensures that the DPLL responds to all input transient conditions with a maximum output phase slope of 5ns per 125us. This is well within the maximum phase slope of 7.6ns per 125us or 81ns per 1.326ms specified by Bellcore GR-1244-CORE Stratum 4E.

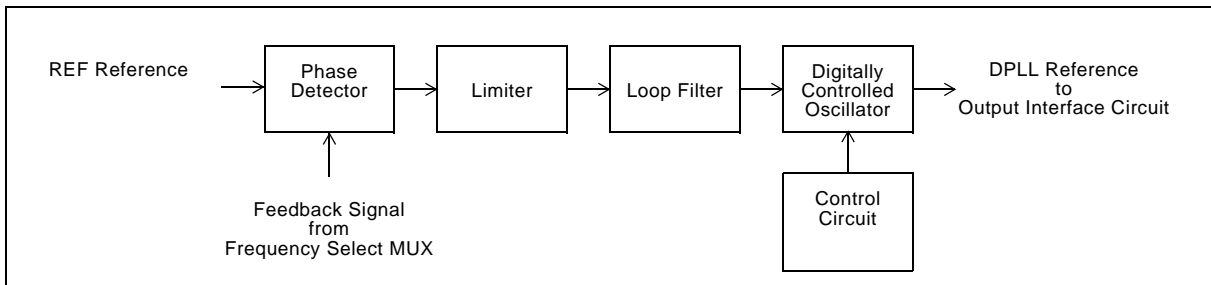

**Figure 3 - DPLL Block Diagram**

**Loop Filter** - the Loop Filter is similar to a first order low pass filter with a 1.9 Hz cutoff frequency for all three reference frequency selections (8kHz, 1.544MHz or 2.048MHz). This filter ensures that the jitter transfer requirements in ETS 300 011 and AT&T TR62411 are met.

**Control Circuit** - the Control Circuit sets the mode of the DPLL. The two possible modes are Normal and Freerun.

**Digitally Controlled Oscillator (DCO)** - the DCO receives the limited and filtered signal from the Loop Filter, and based on its value, generates a corresponding digital output signal. The synchronization method of the DCO is dependent on the state of the MT9041B.

In Normal Mode, the DCO provides an output signal which is frequency and phase locked to the selected input reference signal.

In Freerun Mode, the DCO is free running with an accuracy equal to the accuracy of the OSCi 20MHz source.

### Output Interface Circuit

The output of the DCO (DPLL) is used by the Output Interface Circuit to provide the output signals shown in Figure 4. The Output Interface Circuit uses two Tapped Delay Lines followed by a T1 Divider Circuit and an E1 Divider Circuit to generate the required output signals.

Two tapped delay lines are used to generate a 16.384MHz and a 12.352MHz signals.

The E1 Divider Circuit uses the 16.384MHz signal to generate four clock outputs and three frame pulse outputs. The C8o, C4o and C2o clocks are generated by simply dividing the C16o clock by two, four and eight respectively. These outputs have a nominal 50% duty cycle.

The T1 Divider Circuit uses the 12.384MHz signal to generate two clock outputs. C1.5o and C3o are generated by dividing the internal C12 clock by four and eight respectively. These outputs have a nominal 50% duty cycle.

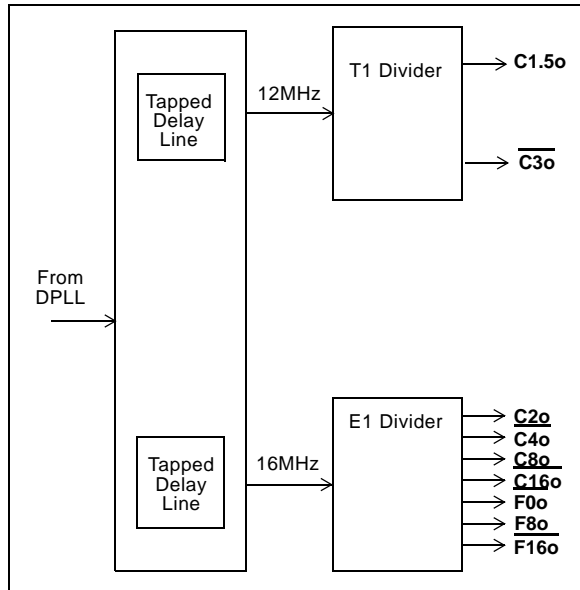

**Figure 4 - Output Interface Circuit Block Diagram**

The frame pulse outputs ( $\overline{F0o}$ ,  $\overline{F8o}$ ,  $\overline{F16o}$ ) are generated directly from the  $\overline{C16o}$  clock.

The T1 and E1 signals are generated from a common DPLL signal. Consequently, the clock outputs  $\overline{C1.5o}$ ,  $\overline{C3o}$ ,  $\overline{C2o}$ ,  $\overline{C4o}$ ,  $\overline{C8o}$ ,  $\overline{C16o}$ ,  $\overline{F0o}$  and  $\overline{F16o}$  are locked to one another for all operating states, and are also locked to the selected input reference in Normal Mode. See Figures 11 and 12.

All frame pulse and clock outputs have limited driving capability, and should be buffered when driving high capacitance (e.g. 30pF) loads.

**Master Clock**

The MT9041B can use either a clock or crystal as the master timing source. For recommended master timing circuits, see the Applications - Master Clock section.

**Control and Modes of Operation**

The MT9041B can operate either in Normal or Freerun modes.

As shown in Table 2, pin MS selects between NORMAL and FREERUN modes.

MS	Description of Operation
0	NORMAL
1	FREERUN

**Table 2 - Operating Modes**

### Normal Mode

Normal Mode is typically used when a slave clock source synchronized to the network is required.

In Normal Mode, the MT9041B provides timing ( $\overline{C1.5o}$ ,  $\overline{C2o}$ ,  $\overline{C3o}$ ,  $\overline{C4o}$ ,  $\overline{C8o}$  and  $\overline{C16o}$ ) and frame synchronization ( $\overline{F0o}$ ,  $\overline{F8o}$ ,  $\overline{F16o}$ ) signals, which are synchronized to reference input (REF). The input reference signal may have a nominal frequency of 8kHz, 1.544MHz or 2.048MHz.

From a reset condition, the MT9041B will take up to 25 seconds for the output signal to be phase locked to the reference.

The reference frequencies are selected by the frequency control pins FS2 and FS1 as shown in Table 1.

### Freerun Mode

Freerun Mode is typically used when a master clock source is required, or immediately following system power-up before network synchronization is achieved.

In Freerun Mode, the MT9041B provides timing and synchronization signals which are based on the master clock frequency (OSCi) only, and are not synchronized to the reference signal (REF).

The accuracy of the output clock is equal to the accuracy of the master clock (OSCi). So if a  $\pm 32$ ppm output clock is required, the master clock must also be  $\pm 32$ ppm. See Applications - Crystal and Clock Oscillator sections.

## MT9041B Measures of Performance

The following are some synchronizer performance indicators and their corresponding definitions.

### Intrinsic Jitter

Intrinsic jitter is the jitter produced by the synchronizing circuit and is measured at its output. It is measured by applying a reference signal with no jitter to the input of the device, and measuring its output jitter. Intrinsic jitter may also be measured when the device is in a non-synchronizing mode, i.e. free running mode, by measuring the output jitter of the device. Intrinsic jitter is usually measured with various bandlimiting filters depending on the applicable standards.

### Jitter Tolerance

Jitter tolerance is a measure of the ability of a PLL to operate properly (i.e., remain in lock and or regain lock), in the presence of large jitter magnitudes at various jitter frequencies applied to its reference. The applied jitter magnitude and jitter frequency depends on the applicable standards.

### Jitter Transfer

Jitter transfer or jitter attenuation refers to the magnitude of jitter at the output of a device for a given amount of jitter at the input of the device. Input jitter is applied at various amplitudes and frequencies, and output jitter is measured with various filters depending on the applicable standards.

For the MT9041B, two internal elements determine the jitter attenuation. This includes the internal 1.9Hz low pass loop filter and the phase slope limiter. The phase slope limiter limits the output phase slope to 5ns/125us. Therefore, if the input signal exceeds this rate, such as for very large amplitude low frequency input jitter, the maximum output phase slope will be limited (i.e., attenuated) to 5ns/125us.

The MT9041B has nine outputs with three possible input frequencies for a total of 27 possible jitter transfer functions. However, the data sheet section on AC Electrical Characteristics - Jitter Transfer specifies transfer values for only three cases, 8kHz to 8kHz, 1.544MHz to 1.544MHz and 2.048MHz to 2.048MHz. Since all outputs are derived from the same signal, these transfer values apply to all outputs.

It should be noted that 1UI at 1.544MHz is 644ns, which is not equal to 1UI at 2.048MHz, which is 488ns. Consequently, a transfer value using different input and output frequencies must be calculated in common units (e.g. seconds) as shown in the following example.

*What is the T1 and E1 output jitter when the T1 input jitter is 20UI (T1 UI Units) and the T1 to T1 jitter attenuation is 18dB?*

$$\begin{aligned} \text{OutputT1} &= \text{InputT1} \times 10^{\left(\frac{-A}{20}\right)} \\ \text{OutputT1} &= 20 \times 10^{\left(\frac{-18}{20}\right)} = 2.5\text{UI}(T1) \\ \text{OutputE1} &= \text{OutputT1} \times \frac{(1\text{UIT1})}{(1\text{UIE1})} \\ \text{OutputE1} &= \text{OutputT1} \times \frac{(644\text{ns})}{(488\text{ns})} = 3.3\text{UI}(T1) \end{aligned}$$

Using the above method, the jitter attenuation can be calculated for all combinations of inputs and outputs based on the three jitter transfer functions provided.

Note that the resulting jitter transfer functions for all combinations of inputs (8kHz, 1.544MHz, 2.048MHz) and outputs (8kHz, 1.544MHz, 2.048MHz, 4.096MHz, 8.192MHz, 16.384MHz) for a given input signal (jitter frequency and jitter amplitude) are the same.

Since intrinsic jitter is always present, jitter attenuation will appear to be lower for small input jitter signals than for large ones. Consequently, accurate jitter transfer function measurements are usually made with large input jitter signals (e.g. 75% of the specified maximum jitter tolerance).

### Frequency Accuracy

Frequency accuracy is defined as the absolute tolerance of an output clock signal when it is not locked to an external reference, but is operating in a free running mode. For the MT9041B, the Freerun accuracy is equal to the Master Clock (OSC<sub>i</sub>) accuracy.

### Capture Range

Also referred to as pull-in range. This is the input frequency range over which the synchronizer must be able to pull into synchronization. The MT9041B capture range is equal to  $\pm 230\text{ppm}$  minus the accuracy of the master clock (OSC<sub>i</sub>). For example, a  $\pm 32\text{ppm}$  master clock results in a capture range of  $\pm 198\text{ppm}$ .

### Lock Range

This is the input frequency range over which the synchronizer must be able to maintain synchronization. The lock range is equal to the capture range for the MT9041B.

### Phase Slope

Phase slope is measured in seconds per second and is the rate at which a given signal changes phase with respect to an ideal signal. The given signal is typically the output signal. The ideal signal is of constant frequency and is nominally equal to the value of the final output signal or final input signal.

### Phase Continuity

Phase continuity is the phase difference between a given timing signal and an ideal timing signal at the end of a particular observation period. Usually, the given timing signal and the ideal timing signal are of the same frequency. Phase continuity applies to the output of the synchronizer after a signal disturbance due to a reference switch or a mode change. The observation period is usually the time from the disturbance, to just after the synchronizer has settled to a steady state.

In the case of the MT9041B, the output signal phase continuity is maintained to within  $\pm 5\text{ns}$  at the instance (over one frame) of mode changes. The total phase shift may accumulate up to  $\pm 200\text{ns}$  over many frames. The rate of change of the  $\pm 200\text{ns}$  phase shift is limited to a maximum phase slope of approximately  $5\text{ns}/125\mu\text{s}$ . This meets the Bellcore GR-1244-CORE maximum phase slope requirement of  $7.6\text{ns}/125\mu\text{s}$  ( $81\text{ns}/1.326\text{ms}$ ).

### Phase Lock Time

This is the time it takes the synchronizer to phase lock to the input signal. Phase lock occurs when the input signal and output signal are not changing in phase with respect to each other (not including jitter).

Lock time is very difficult to determine because it is affected by many factors which include:

- i) initial input to output phase difference
- ii) initial input to output frequency difference
- iii) synchronizer loop filter
- iv) synchronizer limiter

Although a short lock time is desirable, it is not always possible to achieve due to other synchronizer requirements. For instance, better jitter transfer performance is achieved with a lower frequency loop filter which increases lock time. And better (smaller) phase slope performance (limiter) results in longer lock times. The MT9041B loop filter and limiter were optimized to meet the AT&T TR62411 jitter transfer and phase slope requirements. Consequently, phase lock time, which is not a standards requirement, may be longer than in other applications. See AC Electrical Characteristics - Performance for maximum phase lock time.

### MT9041B and Network Specifications

The MT9041B fully meets all applicable PLL requirements (intrinsic jitter, jitter tolerance, jitter transfer, frequency accuracy, capture range and phase change slope) for the following specifications.

1. Bellcore GR-1244-CORE Issue 1, June 1995 for Stratum 4 Enhanced and Stratum 4
2. AT&T TR62411 (DS1) December 1990 for Stratum 4 Enhanced and Stratum 4
3. ANSI T1.101 (DS1) February 1994 for Stratum 4 Enhanced and Stratum 4
4. ETSI 300 011 (E1) April 1992 for Single Access and Multi Access
5. TBR 4 November 1995
6. TBR 12 December 1993
7. TBR 13 January 1996
8. ITU-T I.431 March 1993

### Applications

This section contains MT9041B application specific details for clock and crystal operation, reset operation and power supply decoupling.

### Master Clock

The MT9041B can use either a clock or crystal as the master timing source.

In Freerun Mode, the frequency tolerance at the clock outputs is identical to the frequency tolerance of the source at the OSCi pin. For applications not requiring an accurate Freerun Mode, tolerance of the master timing source may be  $\pm 100\text{ppm}$ . For applications requiring an accurate Freerun Mode, such as Bellcore GR-1244-CORE, the tolerance of the master timing source must be no greater than  $\pm 32\text{ppm}$ .

Another consideration in determining the accuracy of the master timing source is the desired capture range. The sum of the accuracy of the master timing source and the capture range of the MT9041B will always equal  $\pm 230\text{ppm}$ . For example, if the master timing source is  $\pm 100\text{ppm}$ , then the capture range will be  $\pm 130\text{ppm}$ .

**Clock Oscillator** - when selecting a Clock Oscillator, numerous parameters must be considered. These include absolute frequency, frequency change over temperature, output rise and fall times, output levels and duty cycle. See AC Electrical Characteristics.

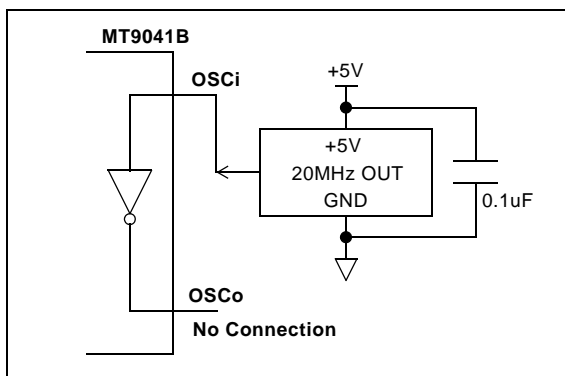

**Figure 5 - Clock Oscillator Circuit**

For applications requiring  $\pm 32\text{ppm}$  clock accuracy, the following clock oscillator module may be used.

*CTS CXO-65-HG-5-C-20.0MHz*

*Frequency: 20MHz*

*Tolerance: 25ppm 0C to 70C*

*Rise & Fall Time: 8ns (0.5V 4.5V 50pF)*

*Duty Cycle: 45% to 55%*

The output clock should be connected directly (not AC coupled) to the OSCi input of the MT9041B, and the OSCo output should be left open as shown in Figure 5.

**Crystal Oscillator** - Alternatively, a Crystal Oscillator may be used. A complete oscillator circuit made up of a crystal, resistor and capacitors is shown in Figure 6.

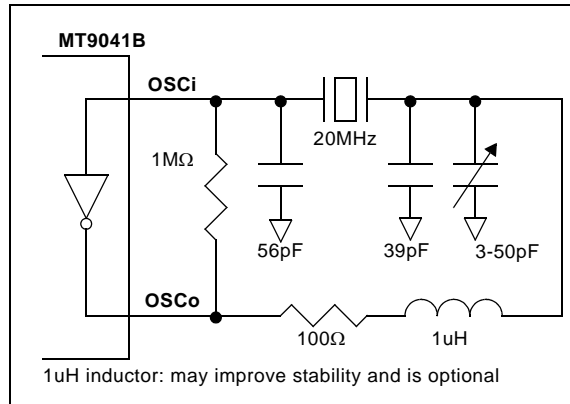

**Figure 6 - Crystal Oscillator Circuit**

The accuracy of a crystal oscillator depends on the crystal tolerance as well as the load capacitance tolerance. Typically, for a 20MHz crystal specified with a 32pF load capacitance, each 1pF change in load capacitance contributes approximately 9ppm to the frequency deviation. Consequently, capacitor tolerances, and stray capacitances have a major effect on the accuracy of the oscillator frequency.

The trimmer capacitor shown in Figure 6 may be used to compensate for capacitive effects. If accuracy is not a concern, then the trimmer may be removed, the 39pF capacitor may be increased to 56pF, and a wider tolerance crystal may be substituted.

The crystal should be a fundamental mode type - not an overtone. The fundamental mode crystal permits a simpler oscillator circuit with no additional filter components and is less likely to generate spurious responses. The crystal specification is as follows.

<i>Frequency:</i>	<i>20MHz</i>
<i>Tolerance:</i>	<i>As required</i>
<i>Oscillation Mode:</i>	<i>Fundamental</i>
<i>Resonance Mode:</i>	<i>Parallel</i>
<i>Load Capacitance:</i>	<i>32pF</i>
<i>Maximum Series Resistance:</i>	<i>35Ω</i>
<i>Approximate Drive Level:</i>	<i>1mW</i>
<i>e.g., CTS R1027-2BB-20.0MHZ</i>	
<i>(±20ppm absolute, ±6ppm 0C to 50C, 32pF, 25Ω)</i>	

**Reset Circuit**

A simple power up reset circuit with about a 50us reset low time is shown in Figure 7. Resistor  $R_P$  is for protection only and limits current into the  $\overline{RST}$  pin during power down conditions. The reset low time is not critical but should be greater than 300ns.

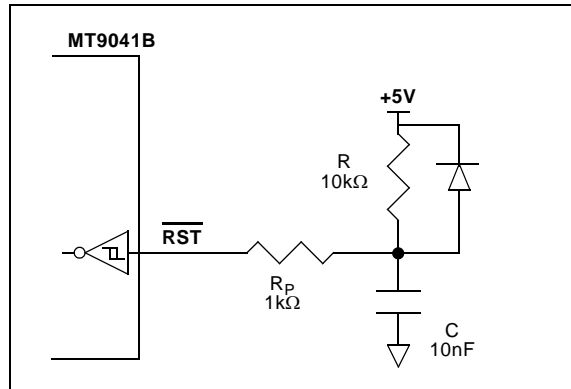

**Figure 7 - Power-Up Reset Circuit**

**Power Supply Decoupling**

The MT9041B has two VDD (+5V) pins and two VSS (GND) pins. Power and decoupling capacitors should be included as shown in Figure 8.

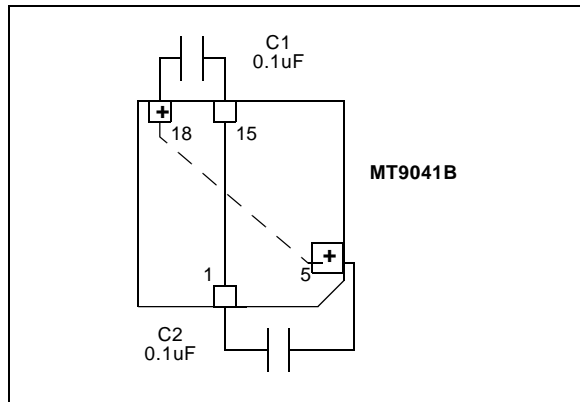

**Figure 8 - Power Supply Decoupling**

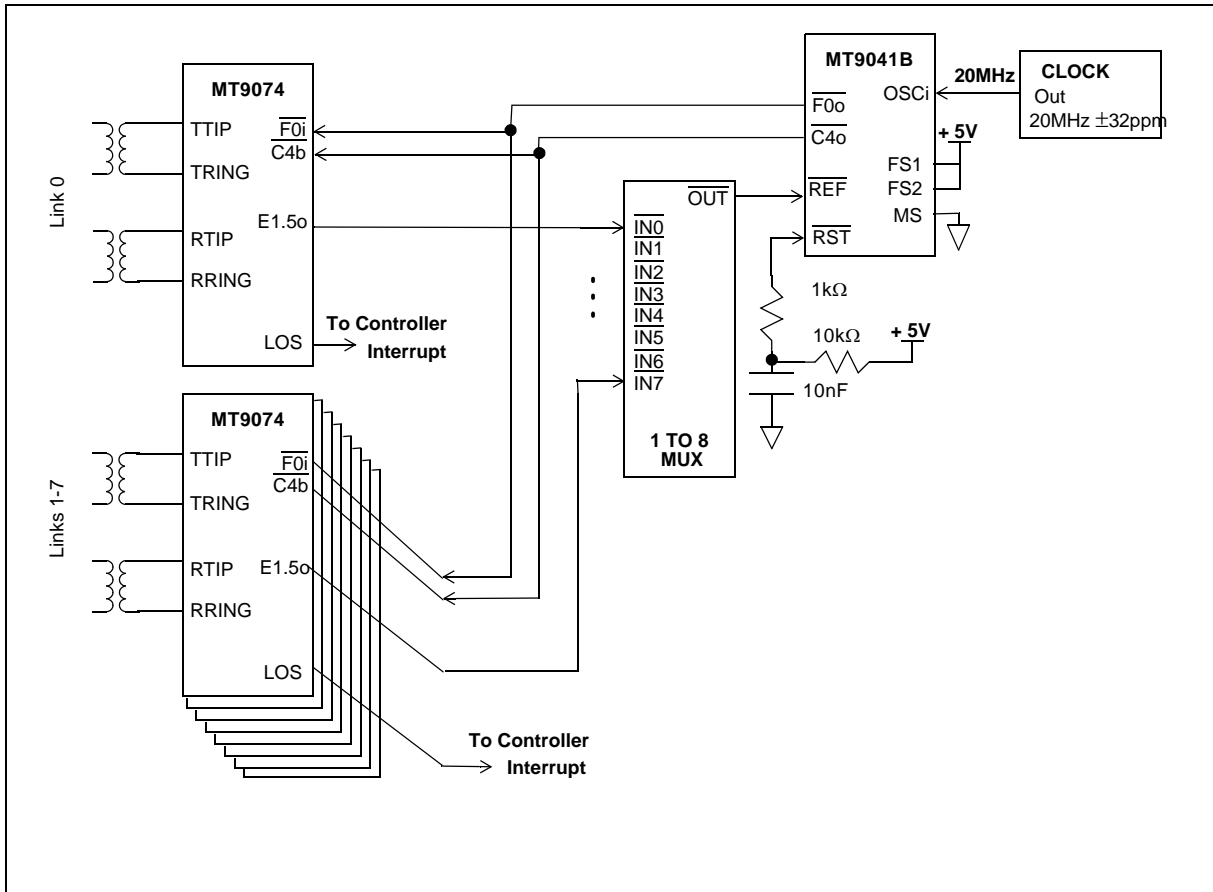

Figure 9 - Multiple E1 Reference Sources with MT9041B

**Multiple E1 Reference Sources with MT9041B**

In this example 8 E1 link framers (MT9074) are connected to a common system backplane clock using the MT9041B. Each of the extracted clocks E1.50 go to a mux which selects one of the eight input clocks as the reference to the MT9041B. The clock choice is made by a controller using the loss of signal pin LOS from the MT9074s to qualify potential references. In the event of loss of signal by one of the framers, an interrupt signals the controller to choose a different reference clock. Disturbances in the generated system backplane clocks C4b and F0b are minimized by the phase slope limitations of the MT9041B PLL. This ensures system integrity and minimizes the effect of clock switchover on downstream trunks.

**Absolute Maximum Ratings\*** - Voltages are with respect to ground ( $V_{SS}$ ) unless otherwise stated.

	Parameter	Symbol	Min	Max	Units
1	Supply voltage	$V_{DD}$	-0.3	7.0	V
2	Voltage on any pin	$V_{PIN}$	-0.3	$V_{DD}+0.3$	V
3	Current on any pin	$I_{PIN}$		20	mA
4	Storage temperature	$T_{ST}$	-55	125	°C
5	PLCC package power dissipation	$P_{PD}$		900	mW

\* Exceeding these values may cause permanent damage. Functional operation under these conditions is not implied.

**Recommended Operating Conditions** - Voltages are with respect to ground ( $V_{SS}$ ) unless otherwise stated

	Characteristics	Sym	Min	Typ	Max	Units
1	Supply voltage	$V_{DD}$	4.5	5.0	5.5	V
2	Operating temperature	$T_A$	-40	25	85	°C

**DC Electrical Characteristics\*** - Voltages are with respect to ground ( $V_{SS}$ ) unless otherwise stated.

	Characteristics	Sym	Min	Max	Units	Conditions/Notes
1	Supply current with: $OSC_i = 0V$	$I_{DDS}$		0.5	mA	Outputs unloaded
2	$OSC_i = \text{Clock}$	$I_{DD}$		60	mA	Outputs unloaded
3	TTL high-level input voltage	$V_{IH}$	2.0		V	
4	TTL low-level input voltage	$V_{IL}$		0.8	V	
5	CMOS high-level input voltage	$V_{CIH}$	$0.7V_{DD}$		V	$OSC_i$
6	CMOS low-level input voltage	$V_{CIL}$		$0.3V_{DD}$	V	$OSC_i$
7	Schmitt high-level input voltage	$V_{SIH}$	2.3		V	$\overline{RST}$
8	Schmitt low-level input voltage	$V_{SIL}$		0.8	V	$\overline{RST}$
9	Schmitt hysteresis voltage	$V_{HYS}$	0.4		V	$\overline{RST}$
10	Input leakage current	$I_{IL}$	-50	+50	$\mu A$	$V_i = V_{DD}$ or $0V$
11	High-level output voltage	$V_{OH}$	2.4V		V	$I_{OH} = 10mA$
12	Low-level output voltage	$V_{OL}$		0.4V	V	$I_{OL} = 10mA$

\* Supply voltage and operating temperature are as per Recommended Operating Conditions.

**AC Electrical Characteristics - Performance**

	Characteristics	Sym	Min	Max	Units	Conditions/Notes†
1	Freerun Mode accuracy with OSCi at:	0ppm	-0	+0	ppm	2-5
2		±32ppm	-32	+32	ppm	2-5
3		±100ppm	-100	+100	ppm	2-5
4	Capture range with OSCi at:	±0ppm	-230	+230	ppm	1,3-5,37
5		±32ppm	-198	+198	ppm	1,3-5, 37
6		±100ppm	-130	+130	ppm	1,3-5,37
7	Phase lock time			30	s	1, 3-11
8	Output phase continuity with:					
9		mode switch to Normal		200	ns	1-11
10		mode switch to Freerun		200	ns	1, 3-11
11	Output phase slope			45	us/s	1-11, 24

† See "Notes" following AC Electrical Characteristics tables.

**AC Electrical Characteristics - Timing Parameter Measurement Voltage Levels\*** - Voltages are with respect to ground (VSS) unless otherwise stated

	Characteristics	Sym	Schmitt	TTL	CMOS	Units
1	Threshold Voltage	$V_T$	1.5	1.5	$0.5V_{DD}$	V
2	Rise and Fall Threshold Voltage High	$V_{HM}$	2.3	2.0	$0.7V_{DD}$	V
3	Rise and Fall Threshold Voltage Low	$V_{LM}$	0.8	0.8	$0.3V_{DD}$	V

\* Supply voltage and operating temperature are as per Recommended Operating Conditions.  
 \* Timing for input and output signals is based on the worst Chislehurst of the combination of TTL and CMOS thresholds.  
 \* See Figure 10.

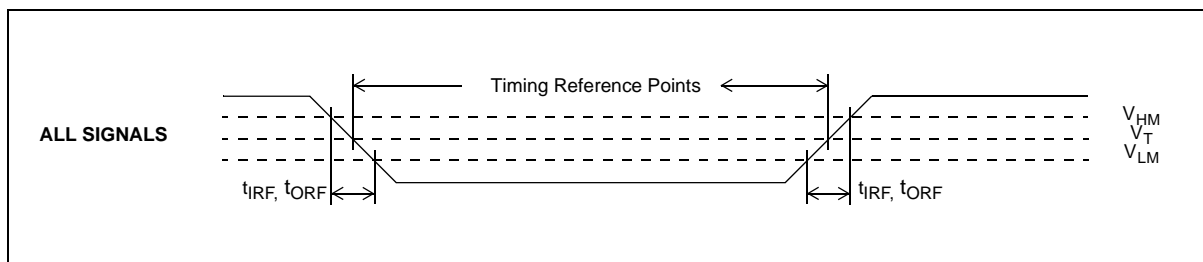

**Figure 10 - Timing Parameter Measurement Voltage Levels**

**AC Electrical Characteristics - Input/Output Timing**

	Characteristics	Sym	Min	Max	Units
1	Reference input pulse width high or low	$t_{RW}$	100		ns
2	Reference input rise or fall time	$t_{IRF}$		10	ns
3	8kHz reference input to F8o delay	$t_{R8D}$	-21	6	ns
4	1.544MHz reference input to F8o delay	$t_{R15D}$	337	363	ns
5	2.048MHz reference input to F8o delay	$t_{R2D}$	222	238	ns
6	F8o to $\overline{F0o}$ delay	$t_{F0D}$	110	134	ns
7	$\overline{F16o}$ setup to $\overline{C16o}$ falling	$t_{F16S}$	11	35	ns
8	$\overline{F16o}$ hold from $\overline{C16o}$ rising	$t_{F16H}$	0	20	ns
9	F8o to C1.5o delay	$t_{C15D}$	-51	-37	ns
10	F8o to $\overline{C3o}$ delay	$t_{C3D}$	-51	-37	ns
11	F8o to C2o delay	$t_{C2D}$	-13	2	ns
12	F8o to $\overline{C4o}$ delay	$t_{C4D}$	-13	2	ns
13	F8o to C8o delay	$t_{C8D}$	-13	2	ns
14	F8o to $\overline{C16o}$ delay	$t_{C16D}$	-13	2	ns
15	C1.5o pulse width high or low	$t_{C15W}$	309	339	ns
16	$\overline{C3o}$ pulse width high or low	$t_{C3W}$	149	175	ns
17	C2o pulse width high or low	$t_{C2W}$	230	258	ns
18	$\overline{C4o}$ pulse width high or low	$t_{C4W}$	111	133	ns
19	C8o pulse width high or low	$t_{C8W}$	52	70	ns
20	$\overline{C16o}$ pulse width high or low	$t_{C16WL}$	24	35	ns
21	$\overline{F0o}$ pulse width low	$t_{F0WL}$	230	258	ns
22	F8o pulse width high	$t_{F8WH}$	111	133	ns
23	$\overline{F16o}$ pulse width low	$t_{F16WL}$	52	70	ns
24	Output clock and frame pulse rise or fall time	$t_{ORF}$		9	ns
25	Input Controls Setup Time	$t_S$	100		ns
26	Input Controls Hold Time	$t_H$	100		ns

† See "Notes" following AC Electrical Characteristics tables.

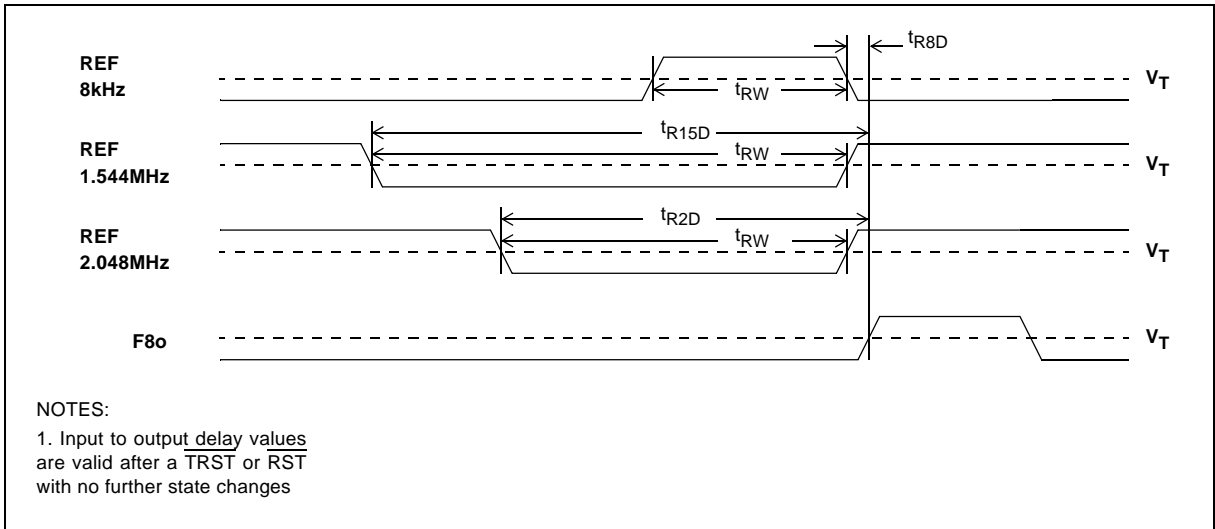

Figure 11 - Input to Output Timing (Normal Mode)

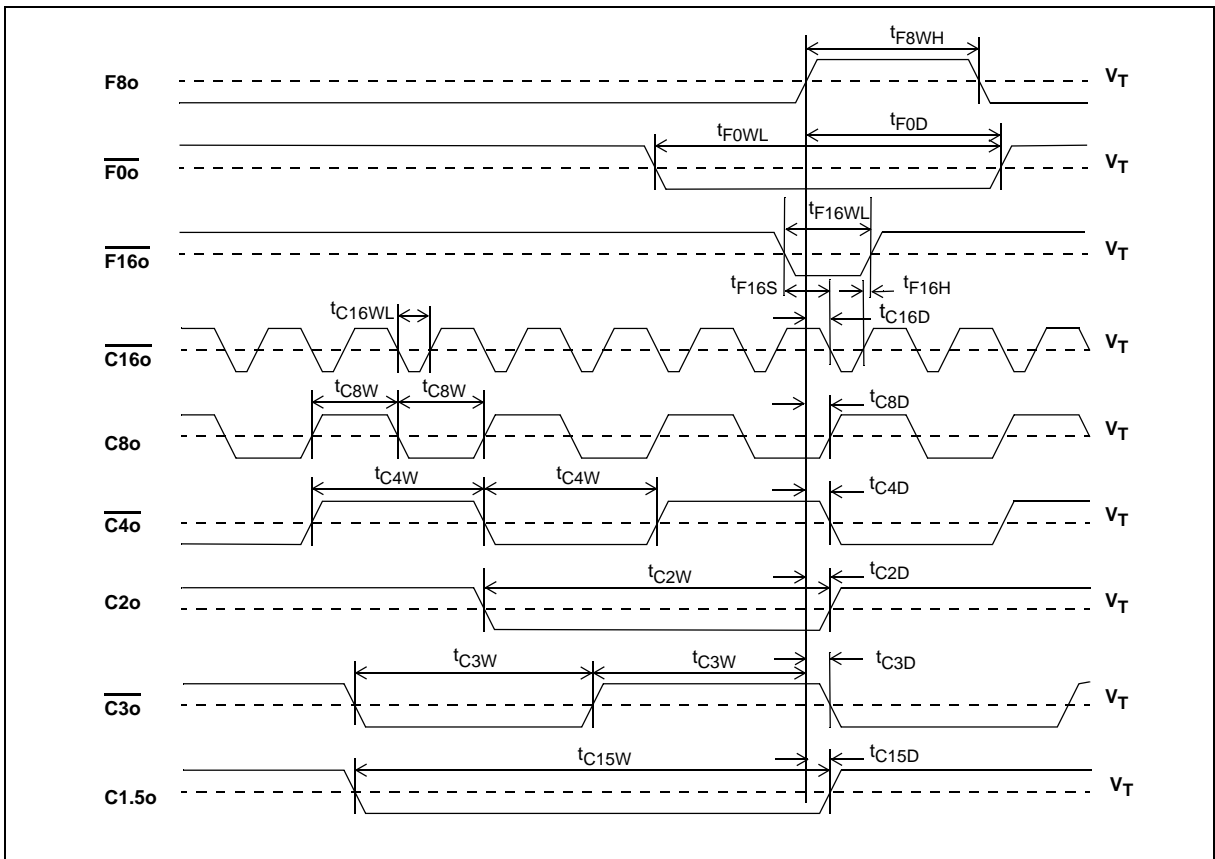

Figure 12 - Output Timing 1

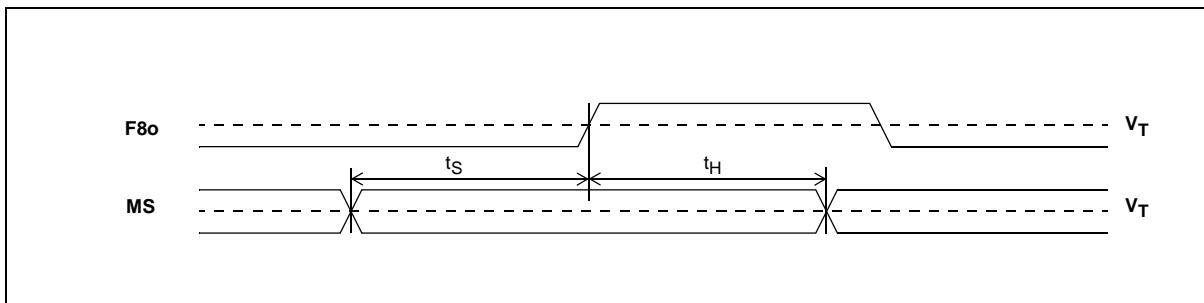

Figure 13 - Input Controls Setup and Hold Timing

**AC Electrical Characteristics - Intrinsic Jitter Unfiltered**

	Characteristics	Sym	Min	Max	Units	Conditions/Notes†
1	Intrinsic jitter at F8o (8kHz)			0.0002	U <sub>Ipp</sub>	1-11,18-21,25
2	Intrinsic jitter at $\overline{F0o}$ (8kHz)			0.0002	U <sub>Ipp</sub>	1-11,18-21,25
3	Intrinsic jitter at $\overline{F16o}$ (8kHz)			0.0002	U <sub>Ipp</sub>	1-11,18-21,25
4	Intrinsic jitter at C1.5o (1.544MHz)			0.030	U <sub>Ipp</sub>	1-11,18-21,26
5	Intrinsic jitter at C2o (2.048MHz)			0.040	U <sub>Ipp</sub>	1-11,18-21,27
6	Intrinsic jitter at $\overline{C3o}$ (3.088MHz)			0.060	U <sub>Ipp</sub>	1-11,18-21,28
7	Intrinsic jitter at $\overline{C4o}$ (4.096MHz)			0.080	U <sub>Ipp</sub>	1-11,18-21,29
8	Intrinsic jitter at C8o (8.192MHz)			0.160	U <sub>Ipp</sub>	1-11,18-21,30
9	Intrinsic jitter at $\overline{C16o}$ (16.384MHz)			0.320	U <sub>Ipp</sub>	1-11,18-21,33

† See "Notes" following AC Electrical Characteristics tables.

**AC Electrical Characteristics - C1.5o (1.544MHz) Intrinsic Jitter Filtered**

	Characteristics	Sym	Min	Max	Units	Conditions/Notes†
1	Intrinsic jitter (4Hz to 100kHz filter)			0.015	U <sub>Ipp</sub>	1-11,18-21,26
2	Intrinsic jitter (10Hz to 40kHz filter)			0.010	U <sub>Ipp</sub>	1-11,18-21,26
3	Intrinsic jitter (8kHz to 40kHz filter)			0.010	U <sub>Ipp</sub>	1-11,18-21,26
4	Intrinsic jitter (10Hz to 8kHz filter)			0.005	U <sub>Ipp</sub>	1-11,18-21,26

† See "Notes" following AC Electrical Characteristics tables.

**AC Electrical Characteristics - C2o (2.048MHz) Intrinsic Jitter Filtered**

	Characteristics	Sym	Min	Max	Units	Conditions/Notes†
1	Intrinsic jitter (4Hz to 100kHz filter)			0.015	U <sub>Ipp</sub>	1-11, 18-21, 27
2	Intrinsic jitter (10Hz to 40kHz filter)			0.010	U <sub>Ipp</sub>	1-11, 18-21, 27
3	Intrinsic jitter (8kHz to 40kHz filter)			0.010	U <sub>Ipp</sub>	1-11, 18-21, 27
4	Intrinsic jitter (10Hz to 8kHz filter)			0.005	U <sub>Ipp</sub>	1-11, 18-21, 27

† See "Notes" following AC Electrical Characteristics tables.

**AC Electrical Characteristics - 8kHz Input to 8kHz Output Jitter Transfer**

	Characteristics	Sym	Min	Max	Units	Conditions/Notes†
1	Jitter attenuation for 1Hz@0.01UIpp input		0	6	dB	1,3,6-11,18-19,21,25,32
2	Jitter attenuation for 1Hz@0.54UIpp input		6	16	dB	1,3,6-11,18-19,21,25,32
3	Jitter attenuation for 10Hz@0.10UIpp input		12	22	dB	1,3,6-11,18-19,21,25,32
4	Jitter attenuation for 60Hz@0.10UIpp input		28	38	dB	1,3,6-11,18-19,21,25,32
5	Jitter attenuation for 300Hz@0.10UIpp input		42		dB	1,3,6-11,18-19,21,25,32
6	Jitter attenuation for 3600Hz@0.005UIpp input		45		dB	1,3,6-11,18-19,21,25,32

† See "Notes" following AC Electrical Characteristics tables.

**AC Electrical Characteristics - 1.544MHz Input to 1.544MHz Output Jitter Transfer**

	Characteristics	Sym	Min	Max	Units	Conditions/Notes†
1	Jitter attenuation for 1Hz@20UIpp input		0	6	dB	1,4,6-11,18-19,21,26,32
2	Jitter attenuation for 1Hz@104UIpp input		6	16	dB	1,4,6-11,18-19,21,26,32
3	Jitter attenuation for 10Hz@20UIpp input		12	22	dB	1,4,6-11,18-19,21,26,32
4	Jitter attenuation for 60Hz@20UIpp input		28	38	dB	1,4,6-11,18-19,21,26,32
5	Jitter attenuation for 300Hz@20UIpp input		42		dB	1,4,6-11,18-19,21,26,32
6	Jitter attenuation for 10kHz@0.3UIpp input		45		dB	1,4,6-11,18-19,21,26,32
7	Jitter attenuation for 100kHz@0.3UIpp input		45		dB	1,4,6-11,18-19,21,26,32

† See "Notes" following AC Electrical Characteristics tables.

**AC Electrical Characteristics - 2.048MHz Input to 2.048MHz Output Jitter Transfer**

	Characteristics	Sym	Min	Max	Units	Conditions/Notes†
1	Jitter at output for 1Hz@3.00U <sub>Ipp</sub> input			2.9	U <sub>Ipp</sub>	1,5,6-11,18-19,21,27,32
2	with 40Hz to 100kHz filter			0.09	U <sub>Ipp</sub>	1-5,6-11,18-19, 21,27,33
3	Jitter at output for 3Hz@2.33U <sub>Ipp</sub> input			1.3	U <sub>Ipp</sub>	1,5,6-11,18-19,21,27,32
4	with 40Hz to 100kHz filter			0.10	U <sub>Ipp</sub>	1-5,6-11,18-19,21,27,33
5	Jitter at output for 5Hz@2.07U <sub>Ipp</sub> input			0.80	U <sub>Ipp</sub>	1,5,6-11,18-19,21,27,32
6	with 40Hz to 100kHz filter			0.10	U <sub>Ipp</sub>	1-5,6-11,18-19, 21,27,33
7	Jitter at output for 10Hz@1.76U <sub>Ipp</sub> input			0.40	U <sub>Ipp</sub>	1,5,6-11,18-19,21,27,32
8	with 40Hz to 100kHz filter			0.10	U <sub>Ipp</sub>	1-5,6-11,18-19, 21,27,33
9	Jitter at output for 100Hz@1.50U <sub>Ipp</sub> input			0.06	U <sub>Ipp</sub>	1,5,6-11,18-19,21,27,32
10	with 40Hz to 100kHz filter			0.05	U <sub>Ipp</sub>	1-5,6-11,18-19, 21,27,33
11	Jitter at output for 2400Hz@1.50U <sub>Ipp</sub> input			0.04	U <sub>Ipp</sub>	1,5,6-11,18-19,21,27,32
12	with 40Hz to 100kHz filter			0.03	U <sub>Ipp</sub>	1-5,6-11,18-19,21,27,33
13	Jitter at output for 100kHz@0.20U <sub>Ipp</sub> input			0.04	U <sub>Ipp</sub>	1,5,6-11,18-19,21,27,32
14	with 40Hz to 100kHz filter			0.02	U <sub>Ipp</sub>	1-5,6-11,18-19,21,27,33

† See "Notes" following AC Electrical Characteristics tables.

**AC Electrical Characteristics - 8kHz Input Jitter Tolerance**

	Characteristics	Sym	Min	Max	Units	Conditions/Notes†
1	Jitter tolerance for 1Hz input		0.80		U <sub>Ipp</sub>	1,3,6-11,18-19,21-23,25
2	Jitter tolerance for 5Hz input		0.70		U <sub>Ipp</sub>	1,3,6-11,18-19,21-23,25
3	Jitter tolerance for 20Hz input		0.60		U <sub>Ipp</sub>	1,3,6-11,18-19,21-23,25
4	Jitter tolerance for 300Hz input		0.20		U <sub>Ipp</sub>	1,3,6-11,18-19,21-23,25
5	Jitter tolerance for 400Hz input		0.15		U <sub>Ipp</sub>	1,3,6-11,18-19,21-23,25
6	Jitter tolerance for 700Hz input		0.08		U <sub>Ipp</sub>	1,3,6-11,18-19,21-23,25
7	Jitter tolerance for 2400Hz input		0.02		U <sub>Ipp</sub>	1,3,6-11,18-19,21-23,25
8	Jitter tolerance for 3600Hz input		0.01		U <sub>Ipp</sub>	1,3,6-11,18-19,21-23,25

† See "Notes" following AC Electrical Characteristics tables.

**AC Electrical Characteristics - 1.544MHz Input Jitter Tolerance**

	Characteristics	Sym	Min	Max	Units	Conditions/Notes†
1	Jitter tolerance for 1Hz input		150		U <sub>Ipp</sub>	1,4,6-11,18-19,21-23,26
2	Jitter tolerance for 5Hz input		140		U <sub>Ipp</sub>	1,4,6-11,18-19,21-23,26
3	Jitter tolerance for 20Hz input		130		U <sub>Ipp</sub>	1,4,6-11,18-19,21-23,26
4	Jitter tolerance for 300Hz input		35		U <sub>Ipp</sub>	1,4,6-11,18-19,21-23,26
5	Jitter tolerance for 400Hz input		25		U <sub>Ipp</sub>	1,4,6-11,18-19,21-23,26
6	Jitter tolerance for 700Hz input		15		U <sub>Ipp</sub>	1,4,6-11,18-19,21-23,26
7	Jitter tolerance for 2400Hz input		4		U <sub>Ipp</sub>	1,4,6-11,18-19,21-23,26
8	Jitter tolerance for 10kHz input		1		U <sub>Ipp</sub>	1,4,6-11,18-19,21-23,26
9	Jitter tolerance for 100kHz input		0.5		U <sub>Ipp</sub>	1,4,6-11,18-19,21-23,26

† See "Notes" following AC Electrical Characteristics tables.

**AC Electrical Characteristics - 2.048MHz Input Jitter Tolerance**

	Characteristics	Sym	Min	Max	Units	Conditions/Notes†
1	Jitter tolerance for 1Hz input		150		U <sub>Ipp</sub>	1,5,6-11,18-19,21-23,27
2	Jitter tolerance for 5Hz input		140		U <sub>Ipp</sub>	1,5,6-11,18-19,21-23,27
3	Jitter tolerance for 20Hz input		130		U <sub>Ipp</sub>	1,5,6-11,18-19,21-23,27
4	Jitter tolerance for 300Hz input		50		U <sub>Ipp</sub>	1,5,6-11,18-19,21-23,27
5	Jitter tolerance for 400Hz input		40		U <sub>Ipp</sub>	1,5,6-11,18-19,21-23,27
6	Jitter tolerance for 700Hz input		20		U <sub>Ipp</sub>	1,5,6-11,18-19,21-23,27
7	Jitter tolerance for 2400Hz input		5		U <sub>Ipp</sub>	1,5,6-11,18-19,21-23,27
8	Jitter tolerance for 10kHz input		1		U <sub>Ipp</sub>	1,5,6-11,18-19,21-23,27
9	Jitter tolerance for 100kHz input		1		U <sub>Ipp</sub>	1,5,6-11,18-19,21-23,27

† See "Notes" following AC Electrical Characteristics tables.

**AC Electrical Characteristics - OSC<sub>i</sub> 20MHz Master Clock Input**

	Characteristics	Sym	Min	Typ	Max	Units	Conditions/Notes†
1	Frequency accuracy (20 MHz nominal)		-0	0	+0	ppm	15,18
2			-32	0	+32	ppm	16,19
3			-100	0	+100	ppm	17,20
4	Duty cycle		40	50	60	%	
5	Rise time				10	ns	
6	Fall time				10	ns	

† See "Notes" following AC Electrical Characteristics tables.

**† Notes:**

Voltages are with respect to ground ( $V_{SS}$ ) unless otherwise stated.  
Supply voltage and operating temperature are as per Recommended Operating Conditions.  
Timing parameters are as per AC Electrical Characteristics - Timing Parameter Measurement Voltage Levels

1. Normal Mode selected.
2. Freerun Mode selected.
3. 8kHz Frequency Mode selected.
4. 1.544MHz Frequency Mode selected.
5. 2.048MHz Frequency Mode selected.
6. Master clock input OSCi at 20MHz  $\pm 0$ ppm.
7. Master clock input OSCi at 20MHz  $\pm 32$ ppm.
8. Master clock input OSCi at 20MHz  $\pm 100$ ppm.
9. Selected reference input at  $\pm 0$ ppm.
10. Selected reference input at  $\pm 32$ ppm.
11. Selected reference input at  $\pm 100$ ppm.
12. For Freerun Mode of  $\pm 0$ ppm.
13. For Freerun Mode of  $\pm 32$ ppm.
14. For Freerun Mode of  $\pm 100$ ppm.
15. For capture range of  $\pm 230$ ppm.
16. For capture range of  $\pm 198$ ppm.
17. For capture range of  $\pm 130$ ppm.
18. 25pF capacitive load.
19. OSCi Master Clock jitter is less than 2nspp, or 0.04UIpp  
where  $1UIpp = 1/20MHz$ .
20. Jitter on reference input is less than 7nspp.
21. Applied jitter is sinusoidal.
22. Minimum applied input jitter magnitude to regain synchronization.
23. Loss of synchronization is obtained at slightly higher input  
jitter amplitudes.
24. Within 10ms of the state, reference or input change.
25.  $1UIpp = 125\mu s$  for 8kHz signals.
26.  $1UIpp = 648ns$  for 1.544MHz signals.
27.  $1UIpp = 488ns$  for 2.048MHz signals.
28.  $1UIpp = 323ns$  for 3.088MHz signals.
29.  $1UIpp = 244ns$  for 4.096MHz signals.
30.  $1UIpp = 122ns$  for 8.192MHz signals.
31.  $1UIpp = 61ns$  for 16.384MHz signals.
32. No filter.
33. 40Hz to 100kHz bandpass filter.
34. With respect to reference input signal frequency.
35. After a RST or TRST.
36. Master clock duty cycle 40% to 60%.

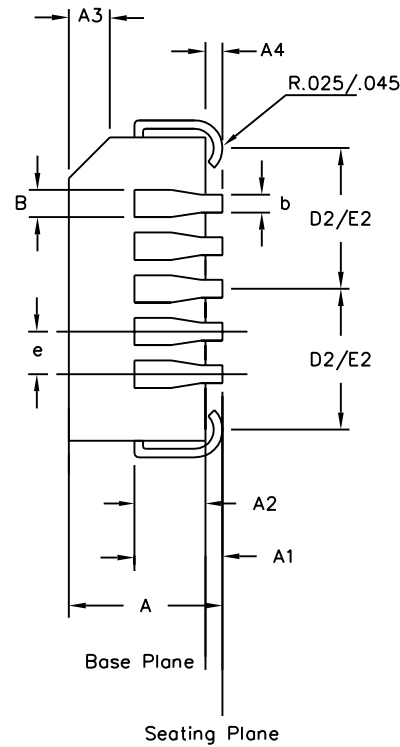
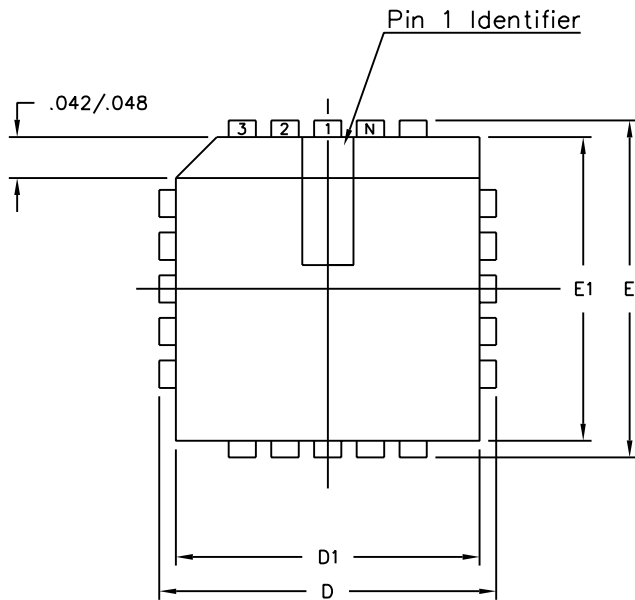

Symbol	Control Dimensions in inches		Altern. Dimensions in millimetres	
	MIN	MAX	MIN	MAX
A	0.165	0.180	4.19	4.57
A1	0.090	0.120	2.29	3.05
A2	0.062	0.083	1.57	2.11
A3	0.042	0.056	1.07	1.42
A4	0.020	—	0.51	—
D	0.485	0.495	12.32	12.57
D1	0.450	0.456	11.43	11.58
D2	0.191	0.219	4.85	5.56
E	0.485	0.495	12.32	12.57
E1	0.450	0.456	11.43	11.58
E2	0.191	0.219	4.85	5.56
B	0.026	0.032	0.66	0.81
b	0.013	0.021	0.33	0.53
e	0.050	BSC	1.27	BSC
Pin features				
ND	7			
NE	7			
N	28			
Note	Square			
Conforms to JEDEC MS-018AB Iss. A				

**Notes:**

1. All dimensions and tolerances conform to ANSI Y14.5M-1982
2. Dimensions D1 and E1 do not include mould protrusions.  
Allowable mould protrusion is 0.010" per side. Dimensions D1 and E1 include mould protrusion mismatch and are determined at the parting line, that is D1 and E1 are measured at the extreme material condition at the upper or lower parting line.
3. Controlling dimensions in Inches.
4. "N" is the number of terminals.
5. Not To Scale
6. Dimension R required for 120° minimum bend.

© Zarlink Semiconductor 2002 All rights reserved.

ISSUE	1	2	3
ACN	5958	207469	212422
DATE	15Aug94	10Sep99	22Mar02
APPRD.			



Previous package codes

HP / P

Package Code QA

Package Outline for  
28 lead PLCC

GPD00002



**For more information about all Zarlink products  
visit our Web Site at  
[www.zarlink.com](http://www.zarlink.com)**

Information relating to products and services furnished herein by Zarlink Semiconductor Inc. or its subsidiaries (collectively "Zarlink") is believed to be reliable. However, Zarlink assumes no liability for errors that may appear in this publication, or for liability otherwise arising from the application or use of any such information, product or service or for any infringement of patents or other intellectual property rights owned by third parties which may result from such application or use. Neither the supply of such information or purchase of product or service conveys any license, either express or implied, under patents or other intellectual property rights owned by Zarlink or licensed from third parties by Zarlink, whatsoever. Purchasers of products are also hereby notified that the use of product in certain ways or in combination with Zarlink, or non-Zarlink furnished goods or services may infringe patents or other intellectual property rights owned by Zarlink.

This publication is issued to provide information only and (unless agreed by Zarlink in writing) may not be used, applied or reproduced for any purpose nor form part of any order or contract nor to be regarded as a representation relating to the products or services concerned. The products, their specifications, services and other information appearing in this publication are subject to change by Zarlink without notice. No warranty or guarantee express or implied is made regarding the capability, performance or suitability of any product or service. Information concerning possible methods of use is provided as a guide only and does not constitute any guarantee that such methods of use will be satisfactory in a specific piece of equipment. It is the user's responsibility to fully determine the performance and suitability of any equipment using such information and to ensure that any publication or data used is up to date and has not been superseded. Manufacturing does not necessarily include testing of all functions or parameters. These products are not suitable for use in any medical products whose failure to perform may result in significant injury or death to the user. All products and materials are sold and services provided subject to Zarlink's conditions of sale which are available on request.

Purchase of Zarlink's I<sup>2</sup>C components conveys a licence under the Philips I<sup>2</sup>C Patent rights to use these components in and I<sup>2</sup>C System, provided that the system conforms to the I<sup>2</sup>C Standard Specification as defined by Philips.

Zarlink, ZL and the Zarlink Semiconductor logo are trademarks of Zarlink Semiconductor Inc.

Copyright Zarlink Semiconductor Inc. All Rights Reserved.

**TECHNICAL DOCUMENTATION - NOT FOR RESALE**

---