

Features

- Supports AT&T TR62411 and Bellcore GR-1244-CORE, Stratum 4 Enhanced and Stratum 4 timing for DS1 interfaces
- Supports ETSI ETS 300 011, TBR 4, TBR 12 and TBR 13 timing for E1 interfaces
- Selectable 19.44 MHz, 1.544 MHz, 2.048 MHz or 8kHz input reference signals
- Provides C1.5, C2, C4, C6, C8, C16, and C19 (STS-3/OC3 clock divided by 8) output clock signals
- Provides 5 styles of 8 KHz framing pulses
- Holdover frequency accuracy of 0.2 PPM
- Holdover indication
- Attenuates wander from 1.9 Hz
- Fast lock mode
- Provides Time Interval Error (TIE) correction
- Accepts reference inputs from two independent sources
- JTAG Boundary Scan

Ordering Information

MT9046AN 48 pin SSOP

-40°C to +85°C
Applications

- Synchronization and timing control for Customer Premises Equipment (CPE)
- ST-BUS clock and frame pulse sources

Description

The MT9046 T1/E1 System Synchronizer contains a digital phase-locked loop (DPLL), which provides timing and synchronization signals for multitruunk T1 and E1 primary rate transmission links. The device has reference switching and frequency holdover capabilities to help maintain connectivity during temporary synchronization interruptions.

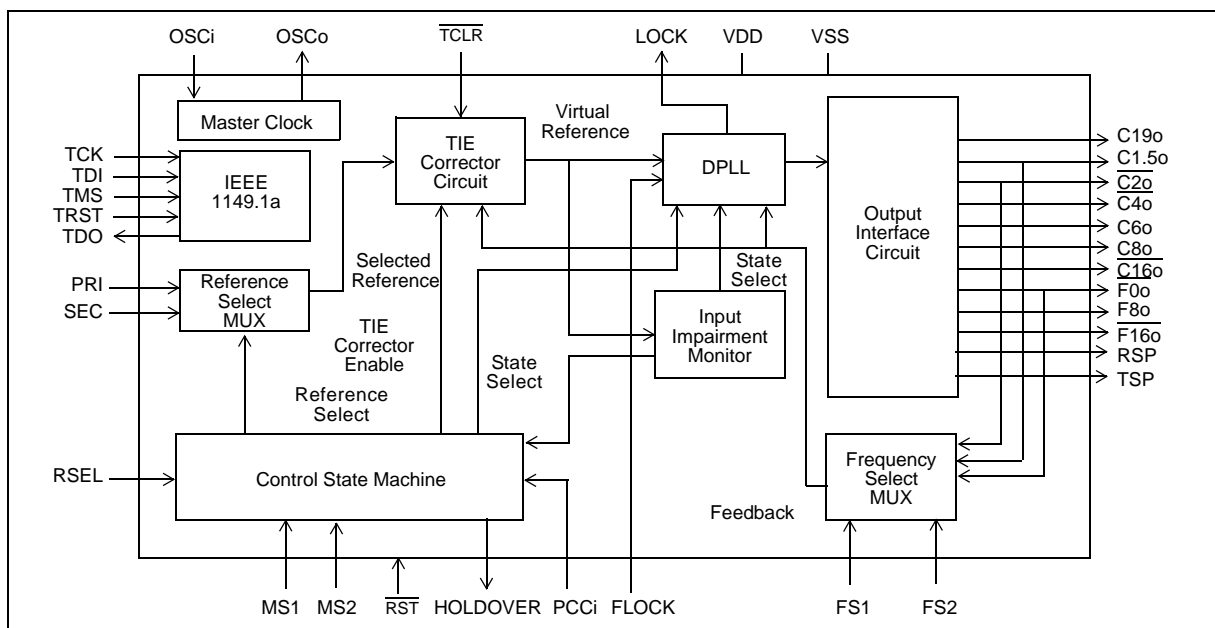
Figure 1 - Functional Block Diagram

**Zarlink Semiconductor US Patent No. 5,602,884, UK Patent No. 0772912,
 France Brevete S.G.D.G. 0772912; Germany DBP No. 69502724.7-08**

The MT9046 generates ST-BUS clock and framing signals that are phase locked to either a 19.44 MHz, 2.048 MHz, 1.544 MHz, or 8 kHz input reference.

The MT9046 is compliant with AT&T TR62411 and Bellcore GR-1244-CORE Stratum 4 Enhanced, and Stratum 4 and ETSI ETS 300 011 interfaces. It will meet the jitter tolerance, jitter transfer, intrinsic jitter, frequency accuracy, capture range, phase change slope frequency and MTIE requirements for these specifications.

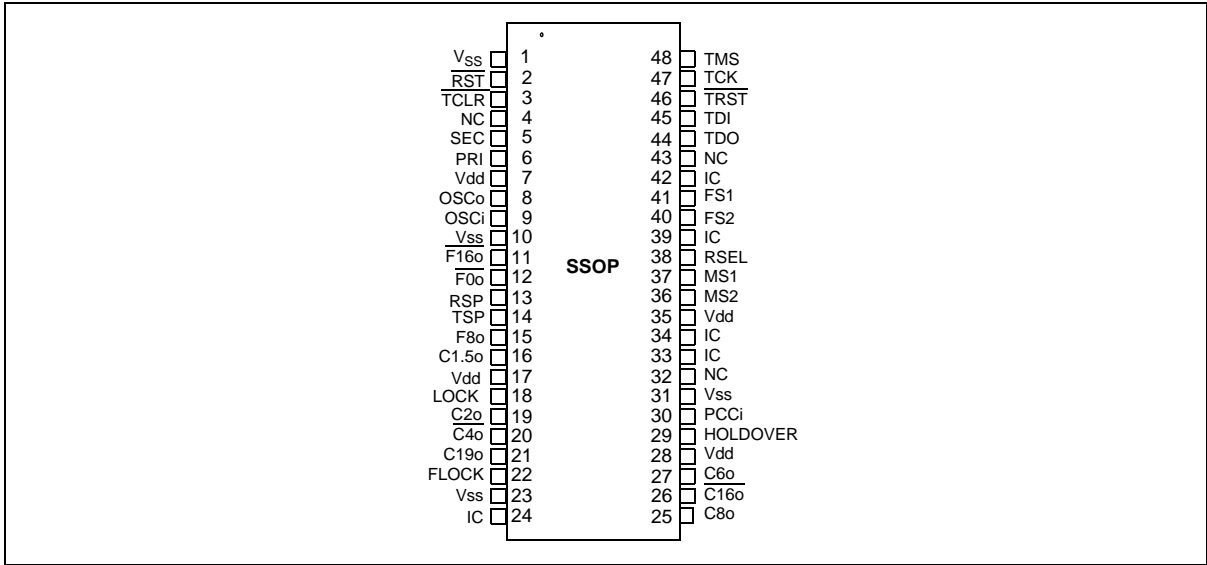

Figure 2 - Pin Connections

Pin Description

Pin #	Name	Description
1,10, 23,31	V _{SS}	Ground. 0 Volts. (Vss pads).
2	$\overline{\text{RST}}$	Reset (Input). A logic low at this input resets the MT9046. To ensure proper operation, the device must be reset after reference signal frequency changes and power-up. The RST pin should be held low for a minimum of 300 ns. While the RST pin is low, all frame pulses except RST and TSP and all clock outputs except C6o, C16o and C19o are at logic high. The RST, TSP, C6o and C16o are at logic low during reset. The C19o is free-running during reset. Following a reset, the input reference source, output clocks and frame pulses are phase aligned as shown in Figure 13.
3	$\overline{\text{TCLR}}$	TIE Circuit Reset (Input). A logic low at this input resets the Time Interval Error (TIE) correction circuit resulting in a realignment of input phase with output phase as shown in Figure 13. The $\overline{\text{TCLR}}$ pin should be held low for a minimum of 300 ns. This pin is internally pulled down to VSS.
4	NC	No Connection. Leave open Circuit
5	SEC	Secondary Reference (Input). This is one of two (PRI & SEC) input reference sources (falling edge) used for synchronization. One of four possible frequencies (8 kHz, 1.544 MHz, 2.048 MHz or 19.44 MHz) may be used. The selection of the input reference is based upon the MS1, MS2, RSEL, and PCCi control inputs. This pin is internally pulled up to V _{DD} .
6	PRI	Primary Reference (Input). See pin description for SEC. This pin is internally pulled up to V _{DD} .
7,17 28,35	V _{DD}	Positive Supply Voltage. +3.3 V _{DC} nominal.
8	OSCo	Oscillator Master Clock (CMOS Output). For crystal operation, a 20 MHz crystal is connected from this pin to OSCi, see Figure 9. For clock oscillator operation, this pin is left unconnected, see Figure 8.
9	OSCi	Oscillator Master Clock (CMOS Input). For crystal operation, a 20 MHz crystal is connected from this pin to OSCo, see Figure 9. For clock oscillator operation, this pin is connected to a clock source, see Figure 8.
11	$\overline{\text{F16o}}$	Frame Pulse ST-BUS 8.192 Mb/s (CMOS Output). This is an 8 kHz 61 ns active low framing pulse, which marks the beginning of an ST-BUS frame. This is typically used for ST-BUS operation at 8.192 Mb/s. See Figure 14.
12	$\overline{\text{F0o}}$	Frame Pulse ST-BUS 2.048 Mb/s (CMOS Output). This is an 8 kHz 244 ns active low framing pulse, which marks the beginning of an ST-BUS frame. This is typically used for ST-BUS operation at 2.048 Mb/s and 4.096 Mb/s. See Figure 14.
13	RSP	Receive Sync Pulse (CMOS Output). This is an 8 kHz 488 ns active high framing pulse, which marks the beginning of an ST-BUS frame. This is typically used for connection to the Siemens MUNICH-32 device. See Figure 15.
14	TSP	Transmit Sync Pulse (CMOS Output). This is an 8 kHz 488 ns active high framing pulse, which marks the beginning of an ST-BUS frame. This is typically used for connection to the Siemens MUNICH-32 device. See Figure 15.
15	F8o	Frame Pulse (CMOS Output). This is an 8 kHz 122 ns active high framing pulse, which marks the beginning of a frame. See Figure 14.
16	C1.5o	Clock 1.544 MHz (CMOS Output). This output is used in T1 applications.

Pin Description (continued)

Pin #	Name	Description
18	LOCK	Lock Indicator (CMOS Output). This output goes high when the PLL is frequency locked to the input reference.
19	C2o	Clock 2.048 MHz (CMOS Output). This output is used for ST-BUS operation at 2.048 Mb/s.
20	C4o	Clock 4.096 MHz (CMOS Output). This output is used for ST-BUS operation at 2.048 Mb/s and 4.096 Mb/s.
21	C19o	Clock 19.44 MHz (CMOS Output). This output is used in OC3/STS3 applications.
22	FLOCK	Fast Lock Mode (Input). Set high to allow the PLL to quickly lock to the input reference (less than 500 ms locking time).
24	IC	Internal Connection. Tie low for normal operation.
25	C8o	Clock 8.192 MHz (CMOS Output). This output is used for ST-BUS operation at 8.192 Mb/s.
26	C16o	Clock 16.384 MHz (CMOS Output). This output is used for ST-BUS operation with a 16.384 MHz clock.
27	C6o	Clock 6.312 Mhz (CMOS Output). This output is used for DS2 applications.
29	HOLD OVER	Holdover (CMOS Output). This output goes to a logic high whenever the PLL goes into holdover mode.
30	PCCi	Phase Continuity Control Input (Input). The signal at this pin affects the state changes between Primary Holdover Mode and Primary Normal Mode, and Primary Holdover Mode and Secondary Normal Mode. The logic level at this input is gated in by the rising edge of F8o. See Table 4.
32	NC	No connection. Leave open circuit
33,34	IC	Internal Connection. Tie low for normal operation.
36	MS2	Mode/Control Select 2 (Input). This input determines the state (Normal, Holdover or Freerun) of operation. The logic level at this input is gated in by the rising edge of F8o. See Table 3.
37	MS1	Mode/Control Select 1 (Input). The logic level at this input is gated in by the rising edge of F8o. See pin description for MS2. This pin is internally pulled down to VSS.
38	RSEL	Reference Source Select (Input). A logic low selects the PRI (primary) reference source as the input reference signal and a logic high selects the SEC (secondary) input. The logic level at this input is gated in by the rising edge of F8o. See Table 2. This pin is internally pulled down to VSS.
39	IC	Internal Connection. Tie low for normal operation.
40	FS2	Frequency Select 2 (Input). This input, in conjunction with FS1, selects which of four possible frequencies (8 kHz, 1.544 MHz, 2.048 MHz or 19.44 MHz) may be input to the PRI and SEC inputs. See Table 1.
41	FS1	Frequency Select 1 (Input). See pin description for FS2.
42	IC	Internal Connection. Tie low for normal operation.
43	NC	No Connection. Leave open Circuit
44	TDO	Test Serial Data Out (CMOS Output). JTAG serial data is output on this pin on the falling edge of TCK. This pin is held in high impedance state when JTAG scan is not enable.

Pin Description (continued)

Pin #	Name	Description
45	TDI	Test Serial Data In (Input). JTAG serial test instructions and data are shifted in on this pin. This pin is internally pulled up to V_{DD} .
46	$\overline{\text{TRST}}$	Test Reset (Input). Asynchronously initializes the JTAG TAP controller by putting it in the Test-Logic-Reset state. If not used, this pin should be held low.
47	TCK	Test Clock (Input): Provides the clock to the JTAG test logic. This pin is internally pulled up to V_{DD} .
48	TMS	Test Mode Select (Input). JTAG signal that controls the state transitions of the TAP controller. This pin is internally pulled up to V_{DD} .

Functional Description

The MT9046 is a Multitrunk System Synchronizer with frequency holdover capability, providing timing (clock) and synchronization (frame) signals to interface circuits for T1 and E1 Primary Rate Digital Transmission links. Figure 1 is a functional block diagram which is described in the following sections.

Reference Select MUX Circuit

The MT9046 accepts two simultaneous reference input signals and operates on their falling edges. Either the primary reference (PRI) signal or the secondary reference (SEC) signal can be selected as input to the TIE Corrector Circuit. The selection is based on the Control, Mode and Reference Selection of the device. See Table 1 and Table 4.

Frequency Select MUX Circuit

The MT9046 operates with one of four possible input reference frequencies (8 kHz, 1.544 MHz, 2.048 MHz or 19.44 MHz). The frequency select inputs (FS1 and FS2) determine which of the four frequencies may be used at the reference inputs (PRI and SEC). Both inputs must have the same frequency applied to them. A reset ($\overline{\text{RST}}$) must be performed after every frequency select input change. See Table 1.

FS2	FS1	Input Frequency
0	0	19.44 MHz
0	1	8 kHz
1	0	1.544 MHz
1	1	2.048 MHz

Table 1 - Input Frequency Selection

Time Interval Error (TIE) Corrector Circuit

The TIE corrector circuit, when enabled, prevents a step change in phase on the input reference signals (PRI or SEC) from causing a step change in phase at the input of the DPLL block of Figure 1.

During reference input rearrangement, such as during a switch from the primary reference (PRI) to the secondary reference (SEC), a step change in phase on the input signals will occur. A phase step at the input of the DPLL would lead to unacceptable phase changes in the output signal.

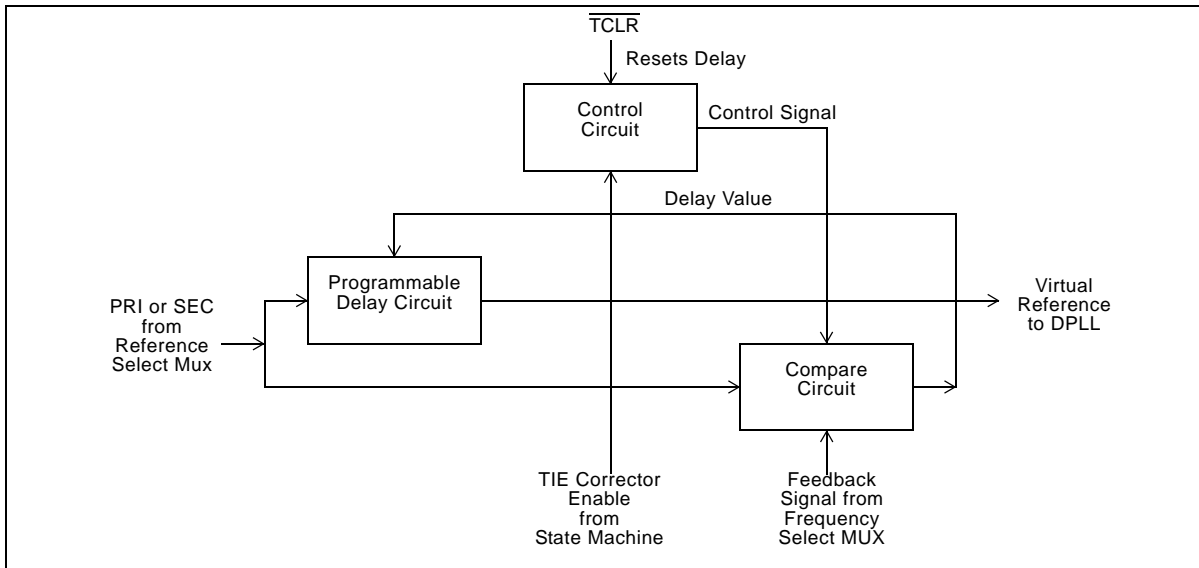

Figure 3 - TIE Corrector Circuit

As shown in Figure 3, the TIE Corrector Circuit receives one of the two reference (PRI or SEC) signals, passes the signal through a programmable delay line, and uses this delayed signal as an internal virtual reference, which is input to the DPLL. Therefore, the virtual reference is a delayed version of the selected reference.

During a switch from one reference to the other, the State Machine first changes the mode of the device

from Normal to Holdover. In Holdover Mode, the DPLL no longer uses the virtual reference signal, but generates an accurate clock signal using storage techniques. The Compare Circuit then measures the phase delay between the current phase (feedback signal) and the phase of the new reference signal. This delay value is passed to the Programmable Delay Circuit (See Figure 3). The new virtual reference signal is now at the same phase position as the previous reference signal would have been if the reference switch not taken place. The State Machine then returns the device to Normal Mode.

The DPLL now uses the new virtual reference signal, and since no phase step took place at the input of the DPLL, no phase step occurs at the output of the DPLL. In other words, reference switching will not create a phase change at the input of the DPLL, or at the output of the DPLL.

Since internal delay circuitry maintains the alignment between the old virtual reference and the new virtual reference, a phase error may exist between the selected input reference signal and the output signal of the DPLL. This phase error is a function of the difference in phase between the two input reference signals during reference rearrangements. Each time a reference switch is made, the delay between input signal and output signal will change. The value of this delay is the accumulation of the error measured during each reference switch.

The programmable delay circuit can be zeroed by applying a logic low pulse to the TIE Circuit Reset ($\overline{\text{TCLR}}$) pin. A minimum reset pulse width is 300 ns. This results in a phase alignment between the input reference signal and the output signal as shown in Figure 14. The speed of the phase alignment correction is limited to 5 ns per 125 us, and convergence is in the direction of least phase travel.

The state diagram of Figure 7 indicates which state changes the TIE Corrector Circuit is activated.

Digital Phase Lock Loop (DPLL)

As shown in Figure 4, the DPLL of the MT9046 consists of a Phase Detector, Limiter, Loop Filter, Digitally Controlled Oscillator, and a Control Circuit.

Phase Detector - the Phase Detector compares the virtual reference signal from the TIE Corrector circuit with the feedback signal from the Frequency Select MUX circuit, and provides an error signal corresponding to the phase difference between the two. This error signal is passed to the Limiter circuit. The Frequency Select MUX allows the proper feedback signal to be externally selected (e.g., 8 kHz, 1.544 MHz, 2.048 MHz or 19.44 MHz).

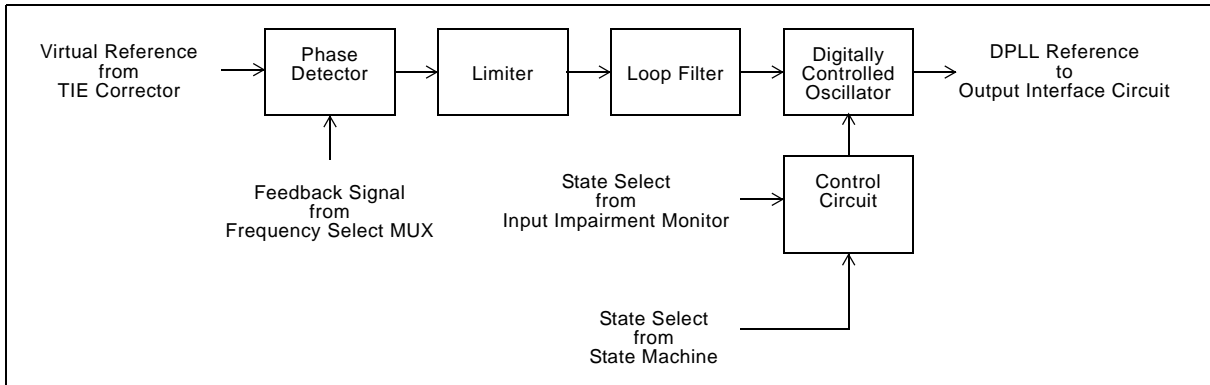

Figure 4 - DPLL Block Diagram

Limiter - the Limiter receives the error signal from the Phase Detector and ensures that the DPLL responds to all input transient conditions with a maximum output phase slope of 5 ns per 125 us. This is well within the maximum phase slope of 7.6 ns per 125 us or 81 ns per 1.326 ms specified by AT&T TR62411 and Bellcore GR-1244-CORE, respectively.

Loop Filter - the Loop Filter is similar to a first order low pass filter with a 1.9 Hz cutoff frequency for all four reference frequency selections (8 kHz, 1.544 MHz, 2.048 MHz or 19.44 MHz). This filter ensures that the jitter transfer requirements in ETS 300 011 and AT&T TR62411 are met.

Control Circuit - the Control Circuit uses status and control information from the State Machine and the Input Impairment Circuit to set the mode of the DPLL. The three possible modes are Normal, Holdover and Freerun.

Digitally Controlled Oscillator (DCO) - the DCO receives the limited and filtered signal from the Loop Filter, and based on its value, generates a corresponding digital output signal. The synchronization method of the DCO is dependent on the state of the MT9046.

In Normal Mode, the DCO provides an output signal which is frequency and phase locked to the selected input reference signal.

In Holdover Mode, the DCO is free running at a frequency equal to the last (less 30 ms to 60 ms) frequency the DCO was generating while in Normal Mode.

In Freerun Mode, the DCO is free running with an accuracy equal to the accuracy of the OSCi 20 MHz source.

Lock Indicator - If the PLL is in frequency lock (frequency lock means the center frequency of the PLL is identical to the line frequency), and the input phase offset is small enough such that no phase slope limiting is exhibited, then the lock signal will be set high. For specific Lock Indicator design recommendations see the Applications - Lock Indicator section.

Output Interface Circuit

The output of the DCO (DPLL) is used by the Output Interface Circuit to provide the output signals shown in Figure 5. The Output Interface Circuit uses four Tapped Delay Lines followed by a T1 Divider Circuit, an E1 Divider Circuit, and a DS2 Divider Circuit to generate the required output signals.

Four tapped delay lines are used to generate 16.384 MHz, 12.352 MHz, 12.624 MHz and 19.44 MHz signals.

The E1 Divider Circuit uses the 16.384 MHz signal to generate four clock outputs and three frame pulse outputs. The C8o, C4o and C2o clocks are generated by simply dividing the C16o clock by two, four and eight respectively. These outputs have a nominal 50% duty cycle.

The T1 Divider Circuit uses the 12.384 MHz signal to generate the C1.5o clock by dividing the internal C12 clock by eight. This output has a nominal 50% duty cycle.

The DS2 Divider Circuit uses the 12.624 MHz signal to generate the clock output C6o. This output has a nominal 50% duty cycle.

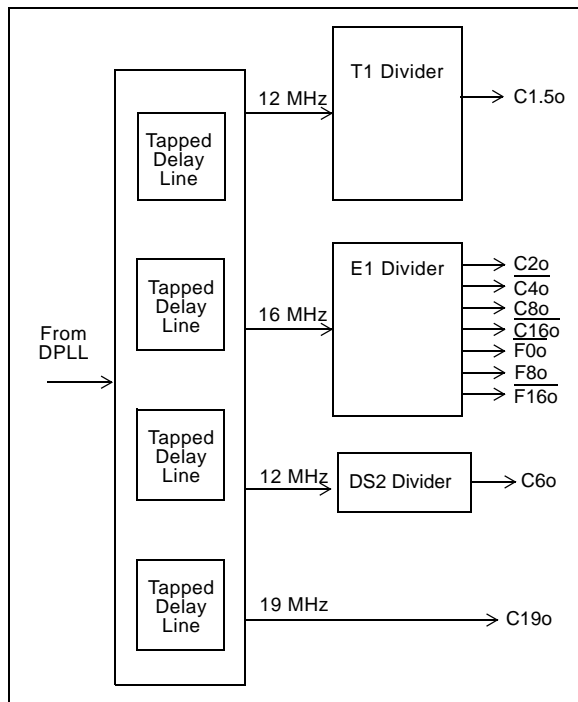

Figure 5 - Output Interface Circuit Block Diagram

The frame pulse outputs ($\overline{F0o}$, F8o, $\overline{F16o}$, TSP, and RSP) are generated directly from the C16 clock.

The T1 and E1 signals are generated from a common DPLL signal. Consequently, all frame pulse and clock outputs are locked to one another for all operating states, and are also locked to the selected input reference in Normal Mode. See Figures 14 & 16.

All frame pulse and clock outputs have limited driving capability, and should be buffered when driving high capacitance (e.g., 30 pF) loads.

Input Impairment Monitor

This circuit monitors the input signal to the DPLL and automatically enables the Holdover Mode (Auto-Holdover) when the frequency of the incoming signal is outside the Auto-Holdover capture range. (See AC Electrical Characteristics - Performance). This includes a complete loss of incoming signal, or a large frequency shift in the incoming signal. When the incoming signal returns to normal, the DPLL is returned to Normal Mode with the output signal locked to the input signal. The holdover output signal in the MT9046 is based on the incoming signal 30 ms minimum to 60 ms prior to entering the Holdover Mode. The amount of phase drift while in holdover is negligible

because the Holdover Mode is very accurate (e.g., ± 0.2 ppm). Consequently, the phase delay between the input and output after switching back to Normal Mode is preserved.

State Machine Control

As shown in Figure 1, this state machine controls the Reference Select MUX, the TIE Corrector Circuit and the DPLL. Control is based on the logic levels at the control inputs RSEL, MS1, MS2 and PCCi (See Figure 6). When switching from Primary Holdover to Primary Normal, the TIE Corrector Circuit is enabled when PCCi = 1, and disabled when PCCi = 0.

All state machine changes occur synchronously on the rising edge of F8o. See the Control and Mode of Operation section for full details.

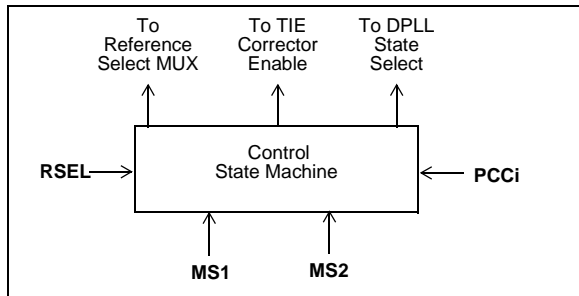

Figure 6 - Control State Machine Block Diagram

Master Clock

The MT9046 can use either a clock or crystal as the master timing source. For recommended master timing circuits, see the Applications - Master Clock section.

Control and Mode of Operation

The active reference input (PRI or SEC) is selected by the RSEL pin as shown in Table 2.

RSEL	Input Reference
0	PRI
1	SEC

Table 2 - Input Reference Selection

MS2	MS1	Mode
0	0	NORMAL
0	1	HOLDOVER
1	0	FREERUN
1	1	Reserved

Table 3 - Operating Modes and States

The MT9046 has three possible modes of operation, Normal, Holdover and Freerun.

As shown in Table 3, Mode/Control Select pins MS2 and MS1 select the mode and method of control. Refer to Table 4 and Figure 7 for details of the state change sequences.

Normal Mode

Normal Mode is typically used when a slave clock source, synchronized to the network is required.

In Normal Mode, the MT9046 provides timing ($C1.5o$, $C2o$, $C4o$, $C8o$, $C16o$ and $C19o$) and frame synchronization ($F0o$, $F8o$, $F16o$, TSP and RSP) signals, which are synchronized to one of two reference inputs (PRI or SEC). The input reference signal may have a nominal frequency of 8 kHz, 1.544 MHz, 2.048 MHz or 19.44 MHz.

From a reset condition, the MT9046 will take up to 30 seconds (see AC Electrical Characteristics) of input reference signal to output signals which are synchronized (phase locked) to the reference input.

The selection of input references is control dependent as shown in state Table 4. The reference frequencies are selected by the frequency control pins FS2 and FS1 as shown in Table 1.

Fast Lock Mode

Fast Lock Mode is a submode of Normal Mode, it is used to allow the MT9046 to lock to a reference more quickly than Normal Mode will allow. Typically, the PLL will lock to the incoming reference within 500 ms if the FLOCK pin is set high.

Holdover Mode

Holdover Mode is typically used for short durations (e.g., 2 seconds) while network synchronization is temporarily disrupted.

In Holdover Mode, the MT9046 provides timing and synchronization signals, which are not locked to an external reference signal, but are based on storage techniques. The storage value is determined while the device is in Normal Mode and locked to an external reference signal

When in Normal Mode, and locked to the input reference signal, a numerical value corresponding to the MT9046 output reference frequency is stored alternately in two memory locations every 30 ms. When the device is switched into Holdover Mode, the value in memory from between 30 ms and 60 ms is used to set the output frequency of the device.

The frequency accuracy of Holdover Mode is ± 0.2 ppm, which translates to a worst case 1 frame (125 us) slip in 10 minutes.

Two factors affect the accuracy of Holdover Mode. One is drift on the Master Clock while in Holdover Mode, drift on the Master Clock directly affects the Holdover Mode accuracy. Note that the absolute Master Clock (OSC_i) accuracy does not affect Holdover accuracy, only the change in OSC_i accuracy while in Holdover. For example, a ± 32 ppm master clock may have a temperature coefficient of ± 0.1 ppm per degree C. So a ± 10 degree change in temperature, while the MT9046 is in Holdover Mode may result in an additional offset (over the ± 0.2 ppm) in frequency accuracy of ± 1 ppm.

The other factor affecting accuracy is large jitter on the reference input prior (30 ms to 60 ms) to the mode switch. For instance, jitter of 7.5 UI at 700 Hz may reduce the Holdover Mode accuracy from ± 0.2 ppm to ± 0.25 ppm.

Freerun Mode

Freerun Mode is typically used when a master clock source is required, or immediately following system power-up before network synchronization is achieved.

In Freerun Mode, the MT9046 provides timing and synchronization signals which are based on the master clock frequency (OSCi) only, and are not synchronized to the reference signals (PRI and SEC).

The accuracy of the output clock is equal to the accuracy of the master clock (OSCi). So if a ± 32 ppm output clock is required, the master clock must also be ± 32 ppm. See Applications - Crystal and Clock Oscillator sections.

MT9046 Measures of Performance

The following are some synchronizer performance indicators and their corresponding definitions.

Intrinsic Jitter

Intrinsic jitter is the jitter produced by the synchronizing circuit and is measured at its output. It is measured by applying a reference signal with no jitter to the input of the device, and measuring its output jitter. Intrinsic jitter may also be measured when the device is in a non-synchronizing mode, such as free running or holdover, by measuring the output jitter of the device. Intrinsic jitter is usually measured with various bandlimiting filters depending on the applicable standards. In the MT9046, the intrinsic Jitter is limited to less than 0.02 UI on the 2.048 MHz and 1.544 MHz clocks.

Jitter Tolerance

Jitter tolerance is a measure of the ability of a PLL to operate properly (i.e., remain in lock and or regain lock in the presence of large jitter magnitudes at various jitter frequencies) when jitter is applied to its reference. The applied jitter magnitude and jitter frequency depends on the applicable standards.

Jitter Transfer

Jitter transfer or jitter attenuation refers to the magnitude of jitter at the output of a device for a given amount of jitter at the input of the device. Input jitter is applied at various amplitudes and frequencies, and output jitter is measured with various filters depending on the applicable standards.

For the MT9046, two internal elements determine the jitter attenuation. This includes the internal 1.9 Hz low pass loop filter and the phase slope limiter. The phase slope limiter limits the output phase slope to 5 ns/125 us. Therefore, if the input signal exceeds this rate, such as for very large amplitude low frequency input jitter, the maximum output phase slope will be limited (i.e., attenuated) to 5 ns/125 us.

The MT9046 has twelve outputs with three possible input frequencies (except for 19.44 MHz, which is internally divided to 8 KHz) for a total of 36 possible jitter transfer functions. Since all outputs are derived from the same signal, the jitter transfer values for the four cases, 8 kHz to 8 kHz, 1.544 MHz to 1.544 MHz and 2.048 MHz to 2.048 MHz can be applied to all outputs.

It should be noted that 1 UI at 1.544 MHz is 644 ns, which is not equal to 1 UI at 2.048 MHz, which is 488 ns. Consequently, a transfer value using different input and output frequencies must be calculated in common units (e.g., seconds) as shown in the following example.

What is the T1 and E1 output jitter when the T1 input jitter is 20UI (T1 UI Units) and the T1 to T1 jitter attenuation is 18 dB?

Using the above method, the jitter attenuation can be calculated for all combinations of inputs and outputs based on the three jitter transfer functions provided.

$$\begin{aligned} \text{OutputT1} &= \text{InputT1} \times 10^{\left(\frac{-A}{20}\right)} \\ \text{OutputT1} &= 20 \times 10^{\left(\frac{-18}{20}\right)} = 2.5\text{UI(T1)} \\ \text{OutputE1} &= \text{OutputT1} \times \frac{(1\text{UIT1})}{(1\text{UIE1})} \\ \text{OutputE1} &= \text{OutputT1} \times \frac{(644\text{ns})}{(488\text{ns})} = 3.3\text{UI(T1)} \end{aligned}$$

Note that the resulting jitter transfer functions for all combinations of inputs (8 kHz, 1.544 MHz, 2.048 MHz) and outputs (8 kHz, 1.544 MHz, 2.048 MHz, 4.096 MHz, 8.192 MHz, 16.384 MHz, 19.44 MHz) for a given input signal (jitter frequency and jitter amplitude) are the same.

Since intrinsic jitter is always present, jitter attenuation will appear to be lower for small input jitter signals than for large ones. Consequently, accurate jitter transfer function measurements are usually made with large input jitter signals (e.g., 75% of the specified maximum jitter tolerance).

Frequency Accuracy

Frequency accuracy is defined as the absolute tolerance of an output clock signal when it is not locked to an external reference, but is operating in a free running mode. For the MT9046, the Freerun accuracy is equal to the Master Clock (OSCi) accuracy.

Holdover Accuracy

Holdover accuracy is defined as the absolute tolerance of an output clock signal, when it is not locked to an external reference signal, but is operating using storage techniques. For the MT9046, the storage value is determined while the device is in Normal Mode and locked to an external reference signal.

The absolute Master Clock (OSCi) accuracy of the MT9046 does not affect Holdover accuracy, but the change in OSCi accuracy while in Holdover Mode does.

Capture Range

Also referred to as pull-in range. This is the input frequency range over which the synchronizer must be able to pull into synchronization. The MT9046 capture range is equal to ± 230 ppm minus the accuracy of the master clock (OSCi). For example, a 32 ppm master clock results in a capture range of 198 ppm.

Lock Range

This is the input frequency range over which the synchronizer must be able to maintain synchronization. The lock range is equal to the capture range for the MT9046.

Phase Slope

Phase slope is measured in seconds per second and is the rate at which a given signal changes phase with respect to an ideal signal. The given signal is typically the output signal. The ideal signal is of constant frequency and is nominally equal to the value of the final output signal or final input signal.

Time Interval Error (TIE)

TIE is the time delay between a given timing signal and an ideal timing signal.

Maximum Time Interval Error (MTIE)

MTIE is the maximum peak to peak delay between a given timing signal and an ideal timing signal within a particular observation period.

$$MTIE(S) = TIE_{max}(t) - TIE_{min}(t)$$

Phase Continuity

Phase continuity is the phase difference between a given timing signal and an ideal timing signal at the end of a particular observation period. Usually, the given timing signal and the ideal timing signal are of the same frequency. Phase continuity applies to the output of the synchronizer after a signal disturbance due to a reference switch or a mode change. The observation period is usually the time from the disturbance, to just after the synchronizer has settled to a steady state.

In the case of the MT9046, the output signal phase continuity is maintained to within ± 5 ns at the instance (over one frame) of all reference switches and all mode changes. The total phase shift, depending on the switch or type of mode change, may accumulate up to 200 ns over many frames. The rate of change of the 200 ns phase shift is limited to a maximum phase slope of approximately 5 ns/125 us. This meets the AT&T TR62411 maximum phase slope requirement of 7.6 ns/125 us and Bellcore GR-1244-CORE (81 ns/1.326 ms).

Phase Lock Time

This is the time it takes the synchronizer to phase lock to the input signal. Phase lock occurs when the input signal and output signal are not changing in phase with respect to each other (not including jitter).

Lock time is very difficult to determine because it is affected by many factors which include:

- initial input to output phase difference
- initial input to output frequency difference
- synchronizer loop filter
- synchronizer limiter

Although a short lock time is desirable, it is not always possible to achieve due to other synchronizer requirements. For instance, better jitter transfer performance is achieved with a lower frequency loop filter which increases lock time. And better (smaller) phase slope performance (limiter) results in longer lock times. The MT9046 loop filter and limiter were optimized to meet the AT&T TR62411 jitter transfer and phase slope requirements. Consequently, phase lock time, which is not a standards requirement, may be longer than in other applications. See AC Electrical Characteristics - Performance for Maximum Phase Lock Time.

MT9046 provides a fast lock pin (FLOCK), which, when set high enables the PLL to lock to an incoming reference within approximately 500 ms.

MT9046 Measures of Performance

The following are some synchronizer performance indicators and their corresponding definitions.

Intrinsic Jitter

Intrinsic jitter is the jitter produced by the synchronizing circuit and is measured at its output. It is measured by applying a reference signal with no jitter to the input of the device, and measuring its output jitter. Intrinsic jitter may also be measured when the device is in a non-synchronizing mode, such as free running or holdover, by measuring the output jitter of the device. Intrinsic jitter is usually measured with various bandlimiting filters depending on the applicable standards. In the MT9046, the intrinsic Jitter is limited to less than 0.02 UI on the 2.048 MHz and 1.544 MHz clocks.

Jitter Tolerance

Jitter tolerance is a measure of the ability of a PLL to operate properly (i.e., remain in lock and or regain lock in the presence of large jitter magnitudes at various jitter frequencies) when jitter is applied to its reference. The applied jitter magnitude and jitter frequency depends on the applicable standards.

Jitter Transfer

Jitter transfer or jitter attenuation refers to the magnitude of jitter at the output of a device for a given amount of jitter at the input of the device. Input jitter is applied at various amplitudes and frequencies, and output jitter is measured with various filters depending on the applicable standards.

For the MT9046, two internal elements determine the jitter attenuation. This includes the internal 1.9 Hz low pass loop filter and the phase slope limiter. The phase slope limiter limits the output phase slope to 5 ns/125 us. Therefore, if the input signal exceeds this rate, such as for very large amplitude low frequency input jitter, the maximum output phase slope will be limited (i.e., attenuated) to 5 ns/125 us.

The MT9046 has twelve outputs with three possible input frequencies (except for 19.44 MHz, which is internally divided to 8 KHz) for a total of 36 possible jitter transfer functions. Since all outputs are derived from the same signal, the jitter transfer values for the four cases, 8 kHz to 8 kHz, 1.544 MHz to 1.544 MHz and 2.048 MHz to 2.048 MHz can be applied to all outputs.

It should be noted that 1 UI at 1.544 MHz is 644 ns, which is not equal to 1 UI at 2.048 MHz, which is 488 ns. Consequently, a transfer value using different input and output frequencies must be calculated in common units (e.g., seconds) as shown in the following example.

What is the T1 and E1 output jitter when the T1 input jitter is 20 UI (T1 UI Units) and the T1 to T1 jitter attenuation is 18 dB?

$$\begin{aligned} \text{OutputT1} &= \text{InputT1} \times 10^{\left(\frac{-A}{20}\right)} \\ \text{OutputT1} &= 20 \times 10^{\left(\frac{-18}{20}\right)} = 2.5\text{UI(T1)} \\ \text{OutputE1} &= \text{OutputT1} \times \frac{(1\text{UIT1})}{(1\text{UIE1})} \\ \text{OutputE1} &= \text{OutputT1} \times \frac{(644\text{ns})}{(488\text{ns})} = 3.3\text{UI(T1)} \end{aligned}$$

Using the above method, the jitter attenuation can be calculated for all combinations of inputs and outputs based on the three jitter transfer functions provided.

Note that the resulting jitter transfer functions for all combinations of inputs (8 kHz, 1.544 MHz, 2.048 MHz) and outputs (8 kHz, 1.544 MHz, 2.048 MHz, 4.096 MHz, 8.192 MHz, 16.384 MHz, 19.44 MHz) for a given input signal (jitter frequency and jitter amplitude) are the same.

Since intrinsic jitter is always present, jitter attenuation will appear to be lower for small input jitter signals than for large ones. Consequently, accurate jitter transfer function measurements are usually made with large input jitter signals (e.g., 75% of the specified maximum jitter tolerance).

Frequency Accuracy

Frequency accuracy is defined as the absolute tolerance of an output clock signal when it is not locked to an external reference, but is operating in a free running mode. For the MT9046, the Freerun accuracy is equal to the Master Clock (OSCi) accuracy.

Holdover Accuracy

Holdover accuracy is defined as the absolute tolerance of an output clock signal, when it is not locked to an external reference signal, but is operating using storage techniques. For the MT9046, the storage value is determined while the device is in Normal Mode and locked to an external reference signal.

The absolute Master Clock (OSCi) accuracy of the MT9046 does not affect Holdover accuracy, but the change in OSCi accuracy while in Holdover Mode does.

Capture Range

Also referred to as pull-in range. This is the input frequency range over which the synchronizer must be able to pull into synchronization. The MT9046 capture range is equal to ± 230 ppm minus the accuracy of the master clock (OSCi). For example, a 32 ppm master clock results in a capture range of 198 ppm.

Lock Range

This is the input frequency range over which the synchronizer must be able to maintain synchronization. The lock range is equal to the capture range for the MT9046.

Phase Slope

Phase slope is measured in seconds per second and is the rate at which a given signal changes phase with respect to an ideal signal. The given signal is typically the output signal. The ideal signal is of constant frequency and is nominally equal to the value of the final output signal or final input signal.

Time Interval Error (TIE)

TIE is the time delay between a given timing signal and an ideal timing signal.

Maximum Time Interval Error (MTIE)

MTIE is the maximum peak to peak delay between a given timing signal and an ideal timing signal within a particular observation period.

$$MTIE(S) = TIE_{max}(t) - TIE_{min}(t)$$

Phase Continuity

Phase continuity is the phase difference between a given timing signal and an ideal timing signal at the end of a particular observation period. Usually, the given timing signal and the ideal timing signal are of the same frequency. Phase continuity applies to the output of the synchronizer after a signal disturbance due to a reference switch or a mode change. The observation period is usually the time from the disturbance, to just after the synchronizer has settled to a steady state.

In the case of the MT9046, the output signal phase continuity is maintained to within ± 5 ns at the instance (over one frame) of all reference switches and all mode changes. The total phase shift, depending on the switch or type of mode change, may accumulate up to 200 ns over many frames. The rate of change of the 200 ns phase shift is limited to a maximum phase slope of approximately 5 ns/125 us. This meets the AT&T TR62411 maximum phase slope requirement of 7.6 ns/125 us and Bellcore GR-1244-CORE (81 ns/1.326 ms).

Phase Lock Time

This is the time it takes the synchronizer to phase lock to the input signal. Phase lock occurs when the input signal and output signal are not changing in phase with respect to each other (not including jitter).

Lock time is very difficult to determine because it is affected by many factors which include:

- initial input to output phase difference
- initial input to output frequency difference
- synchronizer loop filter
- synchronizer limiter

Although a short lock time is desirable, it is not always possible to achieve due to other synchronizer requirements. For instance, better jitter transfer performance is achieved with a lower frequency loop filter which increases lock time. And better (smaller) phase slope performance (limiter) results in longer lock times. The MT9046 loop filter and limiter were optimized to meet the AT&T TR62411 jitter transfer and phase slope requirements. Consequently, phase lock time, which is not a standards requirement, may be longer than in other applications. See AC Electrical Characteristics - Performance for Maximum Phase Lock Time.

MT9046 provides a fast lock pin (FLOCK), which, when set high enables the PLL to lock to an incoming reference within approximately 500 ms.

Description				State				
Input Controls				Freerun	Normal (PRI)	Normal (SEC)	Holdover (PRI)	Holdover (SEC)
MS2	MS1	RSEL	PCCi	S0	S1	S2	S1H	S2H
0	0	0	0	S1	-	S1 MTIE	S1	S1 MTIE
0	0	0	1	S1	-	S1 MTIE	S1 MTIE	S1 MTIE
0	0	1	X	S2	S2 MTIE	-	S2 MTIE	S2 MTIE
0	1	0	X	/	S1H	/	-	/
0	1	1	X	/	S2H	S2H	/	-
1	0	X	X	-	S0	S0	S0	S0

Legend:
 - No Change
 / Not Valid
 MTIE State change occurs with TIE Corrector Circuit
 Refer to Control State Diagram for state changes to and from Auto-Holdover State

Table 4 - Control State Table

Applications

This section contains MT9046 application specific details for clock and crystal operation, reset operation, power supply decoupling, and control operation.

Master Clock

The MT9046 can use either a clock or crystal as the master timing source.

In Freerun Mode, the frequency tolerance at the clock outputs is identical to the frequency tolerance of the source at the OSCi pin. For applications not requiring an accurate Freerun Mode, tolerance of the master timing source may be ± 100 ppm. For applications requiring an accurate Freerun Mode, such as AT&T TR62411, the tolerance of the master timing source must be no greater than ± 32 ppm.

Another consideration in determining the accuracy of the master timing source is the desired capture range. The sum of the accuracy of the master timing source and the capture range of the MT9046 will always equal 230 ppm. For example, if the master timing source is 100 ppm, then the capture range will be 130 ppm.

Clock Oscillator - when selecting a Clock Oscillator, numerous parameters must be considered. This includes absolute frequency, frequency change over temperature, output rise and fall times, output levels and duty cycle.

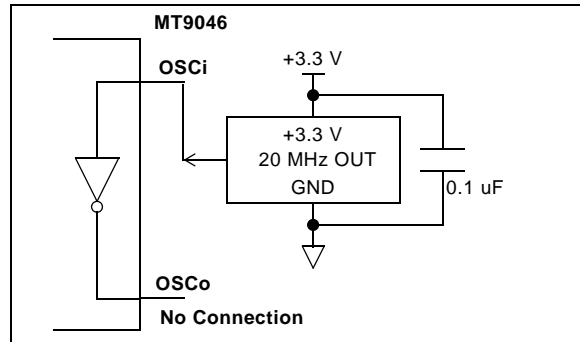

Figure 8 - Clock Oscillator Circuit

For applications requiring ± 32 ppm clock accuracy, the following clock oscillator module may be used.

FOX F7C-2E3-20.0 MHz

Frequency:	20 MHz
Tolerance:	25 ppm 0C to 70C
Rise & Fall Time:	10 ns (0.33 V 2.97 V 15 pF)
Duty Cycle:	40% to 60%

The output clock should be connected directly (not AC coupled) to the OSCi input of the MT9046, and the OSCo output should be left open as shown in Figure 8.

Crystal Oscillator - Alternatively, a Crystal Oscillator may be used. A complete oscillator circuit made up of a crystal, resistor and capacitors is shown in Figure 9.

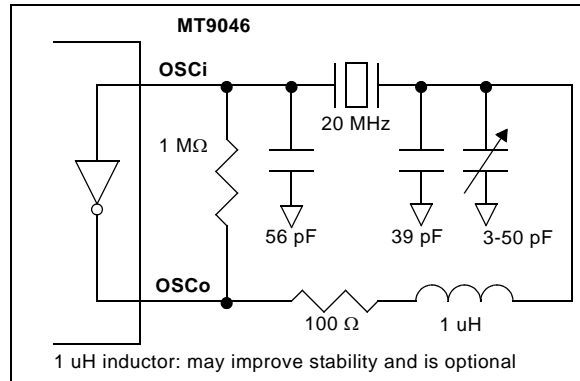

Figure 9 - Crystal Oscillator Circuit

The accuracy of a crystal oscillator depends on the crystal tolerance as well as the load capacitance tolerance. Typically, for a 20 MHz crystal specified with a 32 pF load capacitance, each 1 pF change in load capacitance contributes approximately 9 ppm to the frequency deviation. Consequently, capacitor tolerances, and stray capacitances have a major effect on the accuracy of the oscillator frequency.

The trimmer capacitor shown in Figure 9 may be used to compensate for capacitive effects. If accuracy is not a concern, then the trimmer may be removed, the 39 pF capacitor may be increased to 56 pF, and a wider tolerance crystal may be substituted.

The crystal should be a fundamental mode type - not an overtone. The fundamental mode crystal permits a simpler oscillator circuit with no additional filter components and is less likely to generate spurious responses. The crystal specification is as follows.

Frequency:	20 MHz
Tolerance:	As required
Oscillation Mode:	Fundamental
Resonance Mode:	Parallel
Load Capacitance:	32 pF
Maximum Series Resistance:	35 Ω
Approximate Drive Level:	1 mW
e.g., R1B23B32-20.0 MHz	
(20 ppm absolute, ±6 ppm 0C to 50C, 32 pF, 25 Ω)	

TIE Correction (using PCCi)

When Primary Holdover Mode is entered for short time periods, TIE correction should not be enabled. This will prevent unwanted accumulated phase change between the input and output.

For instance, 10 Normal to Holdover to Normal mode change sequences occur, and in each case Holdover was entered for 2s. Each mode change sequence could account for a phase change as large as 350 ns. Thus, the accumulated phase change could be as large as 3.5 us, and, the overall MTIE could be as large as 3.5 us.

$$\text{Phase}_{\text{hold}} = 0.2\text{ppm} \times 2\text{s} = 400\text{ns}$$

$$\text{Phase}_{\text{state}} = 50\text{ns} + 200\text{ns} = 250\text{ns}$$

$$\text{Phase}_{10} = 10 \times (250\text{ns} + 400\text{ns}) = 6.5\mu\text{s}$$

- 0.2 ppm is the accuracy of Holdover Mode
- 50 ns is the maximum phase continuity of the MT9046 from Normal Mode to Holdover Mode
- 200 ns is the maximum phase continuity of the MT9046 from Holdover Mode to Normal Mode (with or without TIE Corrector Circuit)

When 10 Normal to Holdover to Normal mode change sequences occur without MTIE enabled, and in each case holdover was entered for 2s, each mode change sequence could still account for a phase change as large as 650 ns. However, there would be no accumulated phase change, since the input to output phase is re-aligned after every Holdover to Normal state change. The overall MTIE would only be 650 ns.

Reset Circuit

A simple power up reset circuit with about a 50 us reset low time is shown in Figure 10. Resistor R_P is for protection only and limits current into the RST pin during power down conditions. The reset low time is not critical but should be greater than 300 ns.

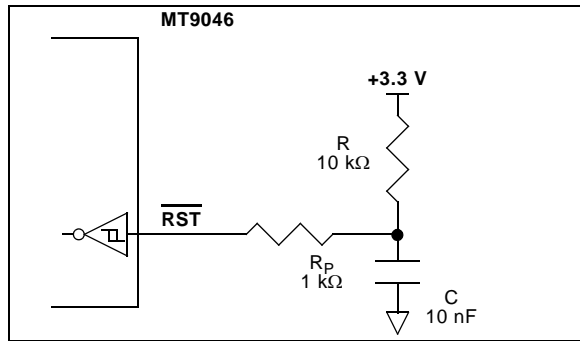

Figure 10 - Power-Up Reset Circuit

Lock Indicator

The LOCK pin toggles at a random rate when the PLL is frequency locked to the input reference. In Figure 11 the RC-time-constant circuit can be used to hold the high state of the LOCK pin.

Once the PLL is frequency locked to the input reference, the minimum duration of LOCK pin's high state would be 32 ms and the maximum duration of LOCK pin's low state would not exceed 1 second. The following equations can be used to calculate the charge and discharge times of the capacitor.

$$t_C = -R_D C \ln(1 - V_{T+}/V_{DD}) = 240 \mu\text{s}$$

t_C = Capacitor's charge time

R_D = Dynamic resistance of the diode (100 Ω)

C = Capacitor value (1 μF)

V_{T+} = Positive going threshold voltage of the Schmitt Trigger (3.0 V)

$V_{DD} = 3.3\text{ V}$

$t_D = -R C \ln(V_T / V_{DD}) = 1.65\text{ seconds}$

t_D = Capacitor's discharge time

R = Resistor value (3.3 M Ω)

C = Capacitor value (1 μ F)

V_T = Negative going threshold voltage of the Schmitt Trigger (2.0 V)

$V_{DD} = 3.3\text{ V}$

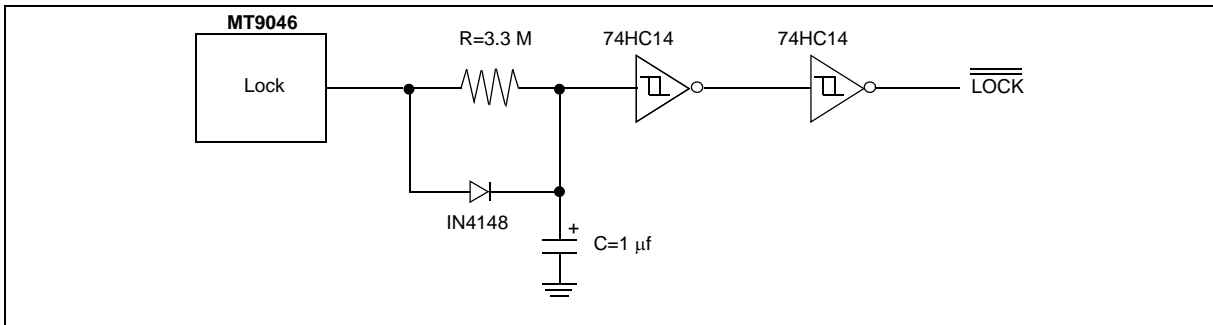

Figure 11 - Time-constant Circuit

A digital alternative to the RC-time-constant circuit is presented in Figure 12. The circuit in Figure 12 can be used to generate a steady lock signal. The circuit monitors the MT9046's LOCK pin, as long as it detects a positive pulse every 1.024 seconds or less, the Advanced Lock output will remain high. If no positive pulse is detected on the LOCK output within 1.024 seconds, the Advanced LOCK output will go low.

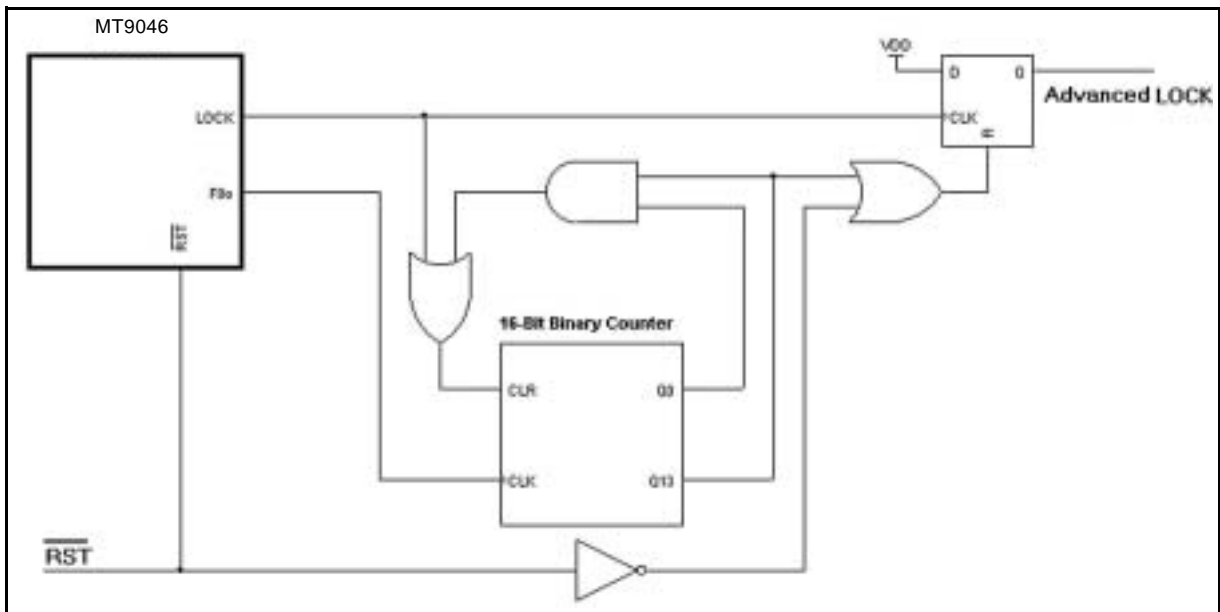

Figure 12 - Digital Lock Pin Circuit

Absolute Maximum Ratings* - Voltages are with respect to ground (V_{SS}) unless otherwise stated.

	Parameter	Symbol	Min.	Max.	Units
1	Supply voltage	V_{DD}	-0.3	7.0	V
2	Voltage on any pin	V_{PIN}	-0.3	$V_{DD} + 0.3$	V
3	Current on any pin	I_{PIN}		30	mA
4	Storage temperature	T_{ST}	-55	125	° C
5	48 SSOP package power dissipation	P_{PD}		200	mW

* Exceeding these values may cause permanent damage. Functional operation under these conditions is not implied.

Recommended Operating Conditions - Voltages are with respect to ground (V_{SS}) unless otherwise stated.

	Characteristics	Sym.	Min.	Max.	Units
1	Supply voltage	V_{DD}	3.0	3.6	V
2	Operating temperature	T_A	-40	85	° C

DC Electrical Characteristics* - Voltages are with respect to ground (V_{SS}) unless otherwise stated.

	Characteristics	Sym.	Min.	Max.	Units	Conditions/Notes
1	Supply current with: $OSC_i = 0\text{ V}$	I_{DDS}		1.8	mA	Outputs unloaded
2	$OSC_i = \text{Clock}$	I_{DD}		50	mA	Outputs unloaded
3	CMOS high-level input voltage	V_{CIH}	$0.7V_{DD}$		V	OSC_i
4	CMOS low-level input voltage	V_{CIL}		$0.3V_{DD}$	V	OSC_i
5	Input leakage current	I_{IL}	-15	15	μA	$V_I = V_{DD}$ or 0 V
6	High-level output voltage	V_{OH}	2.4		V	$I_{OH} = 10\text{ mA}$
7	Low-level output voltage	V_{OL}		0.4	V	$I_{OL} = 10\text{ mA}$

* Supply voltage and operating temperature are as per Recommended Operating Conditions.

AC Electrical Characteristics - Performance

	Characteristics	Sym.	Min.	Max.	Units	Conditions/ Notes†
1	Freerun Mode accuracy with OSCi at: ± 0 ppm		-0	+0	ppm	5-9
2	± 32 ppm		-32	+32	ppm	5-9
3	± 100 ppm		-100	+100	ppm	5-9
4	Holdover Mode accuracy with OSCi at: ± 0 ppm		-0.2	+0.2	ppm	1,2,4,6-9,41
5	± 32 ppm		-0.2	+0.2	ppm	1,2,4,6-9,41
6	± 100 ppm		-0.2	+0.2	ppm	1,2,4,6-9,41
7	Capture range with OSCi at: ± 0 ppm		-230	+230	ppm	1-3,6-9
8	± 32 ppm		-198	+198	ppm	1-3,6-9
9	± 100 ppm		-130	+130	ppm	1-3,6-9
10	Phase lock time			30	s	1-3,6-15
11	Output phase continuity with: reference switch			200	ns	1-3,6-15
12	mode switch to Normal			200	ns	1-2,4-15
13	mode switch to Freerun			200	ns	1-,4,6-15
14	mode switch to Holdover			50	ns	1-3,6-15
15	MTIE (maximum time interval error)			600	ns	1-15,28
16	Output phase slope			45	us/s	1-15,28
17	Reference input for Auto-Holdover with: 8kHz, 19.44 MHz		-30 k	+30 k	ppm	1-3,6,9,10-12
18	1.544 MHz		-30 k	+30 k	ppm	1-3,7,10-12
19	2.048 MHz		-30 k	+30 k	ppm	1-3,8,10-12

† See "Notes" following AC Electrical Characteristics tables.

AC Electrical Characteristics - Timing Parameter Measurement Voltage Levels* - Voltages are with respect to ground (V_{SS}) unless otherwise stated

	Characteristics	Sym.	CMOS	Units
1	Threshold Voltage	V_T	$0.5 V_{DD}$	V
2	Rise and Fall Threshold Voltage High	V_{HM}	$0.7 V_{DD}$	V
3	Rise and Fall Threshold Voltage Low	V_{LM}	$0.3 V_{DD}$	V

* Supply voltage and operating temperature are as per Recommended Operating Conditions.

* Timing for input and output signals is based on the worst case result of the CMOS thresholds.

* See Figure 12.

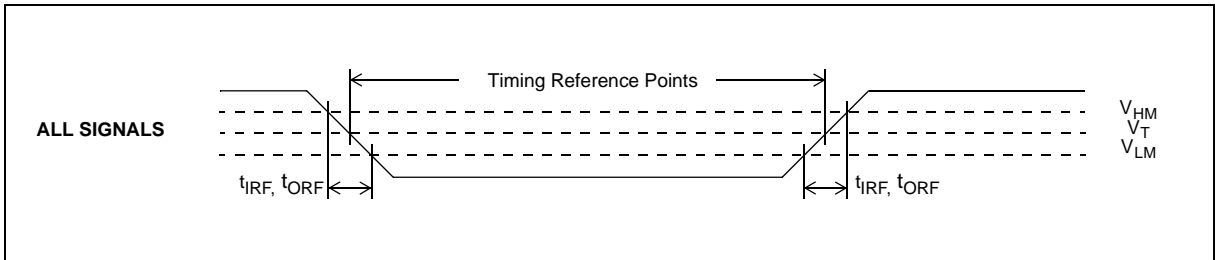

Figure 13 - Timing Parameter Measurement Voltage Levels

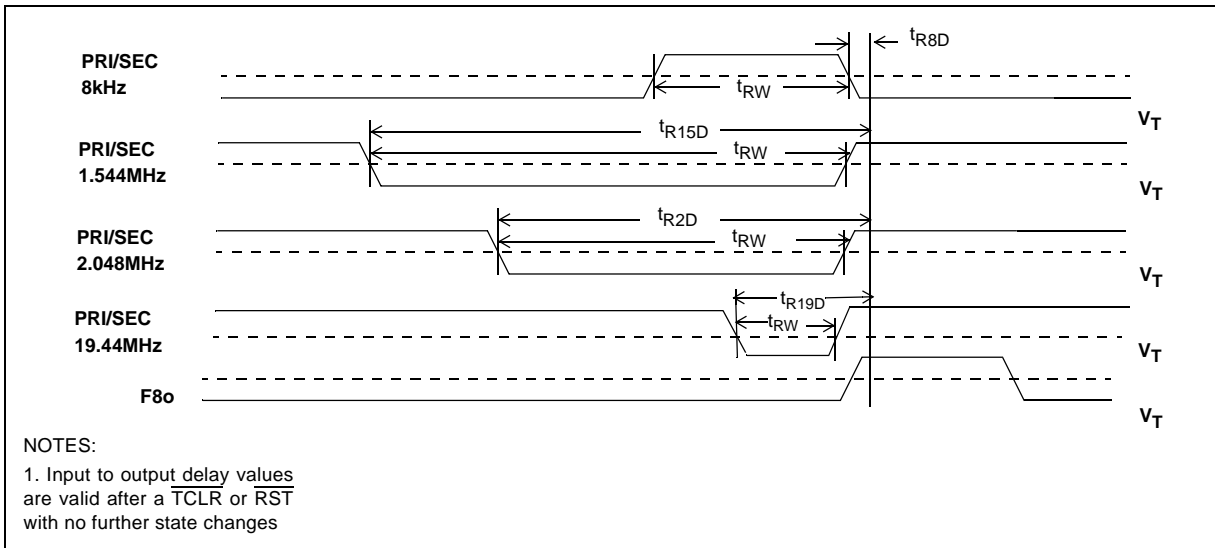

Figure 14 - Input to Output Timing (Normal Mode)

AC Electrical Characteristics - Input/Output Timing

	Characteristics	Sym.	Min.	Max.	Units
1	Reference input pulse width high or low	t_{RW}	100		ns
2	Reference input rise or fall time	t_{IRF}		10	ns
3	8kHz reference input to F8o delay	t_{R8D}	-21	6	ns
4	1.544 MHz reference input to F8o delay	t_{R15D}	337	363	ns
5	2.048 MHz reference input to F8o delay	t_{R2D}	222	238	ns
6	19.44 MHz reference input to F8o delay	t_{R19D}	46	57	ns
7	F8o to $\overline{F0o}$ delay	t_{F0D}	111	130	ns
8	$\overline{F16o}$ setup to C16o falling	t_{F16S}	25	40	ns
9	$\overline{F16o}$ hold to C16o rising	t_{F16H}	-10	10	ns
10	F8o to C1.5o delay	t_{C15D}	-45	-25	ns
11	F8o to C6o delay	t_{C6D}	-10	10	ns
12	F8o to C2o delay	t_{C2D}	-11	5	ns
13	F8o to C4o delay	t_{C4D}	-11	5	ns
14	F8o to C8o delay	t_{C8D}	-11	5	ns
15	F8o to C16o delay	t_{C16D}	-11	5	ns
16	F8o to TSP delay	t_{TSPD}	-6	10	ns
17	F8o to RSP delay	t_{RSPD}	-8	8	ns
18	F8o to C19o delay	t_{C19D}	-15	5	ns
19	C1.5o pulse width high or low	t_{C15W}	309	339	ns
20	C6o pulse width high or low	t_{C6W}	70	86	ns
21	C2o pulse width high or low	t_{C2W}	230	258	ns
22	C4o pulse width high or low	t_{C4W}	111	133	ns
23	C8o pulse width high or low	t_{C8W}	52	70	ns
24	C16o pulse width high or low	t_{C16WL}	24	35	ns
25	TSP pulse width high	t_{TSPW}	478	494	ns
26	RSP pulse width high	t_{RSPW}	474	491	ns
27	C19o pulse width high	t_{C19WH}	25	35	ns
28	C19o pulse width low	t_{C19WL}	17	25	ns
29	$\overline{F0o}$ pulse width low	t_{F0WL}	234	254	ns
30	F8o pulse width high	t_{F8WH}	109	135	ns
31	$\overline{F16o}$ pulse width low	t_{F16WL}	47	75	ns
32	Output clock and frame pulse rise or fall time	t_{ORF}		9	ns
33	Input Controls Setup Time	t_S	100		ns
34	Input Controls Hold Time	t_H	100		ns

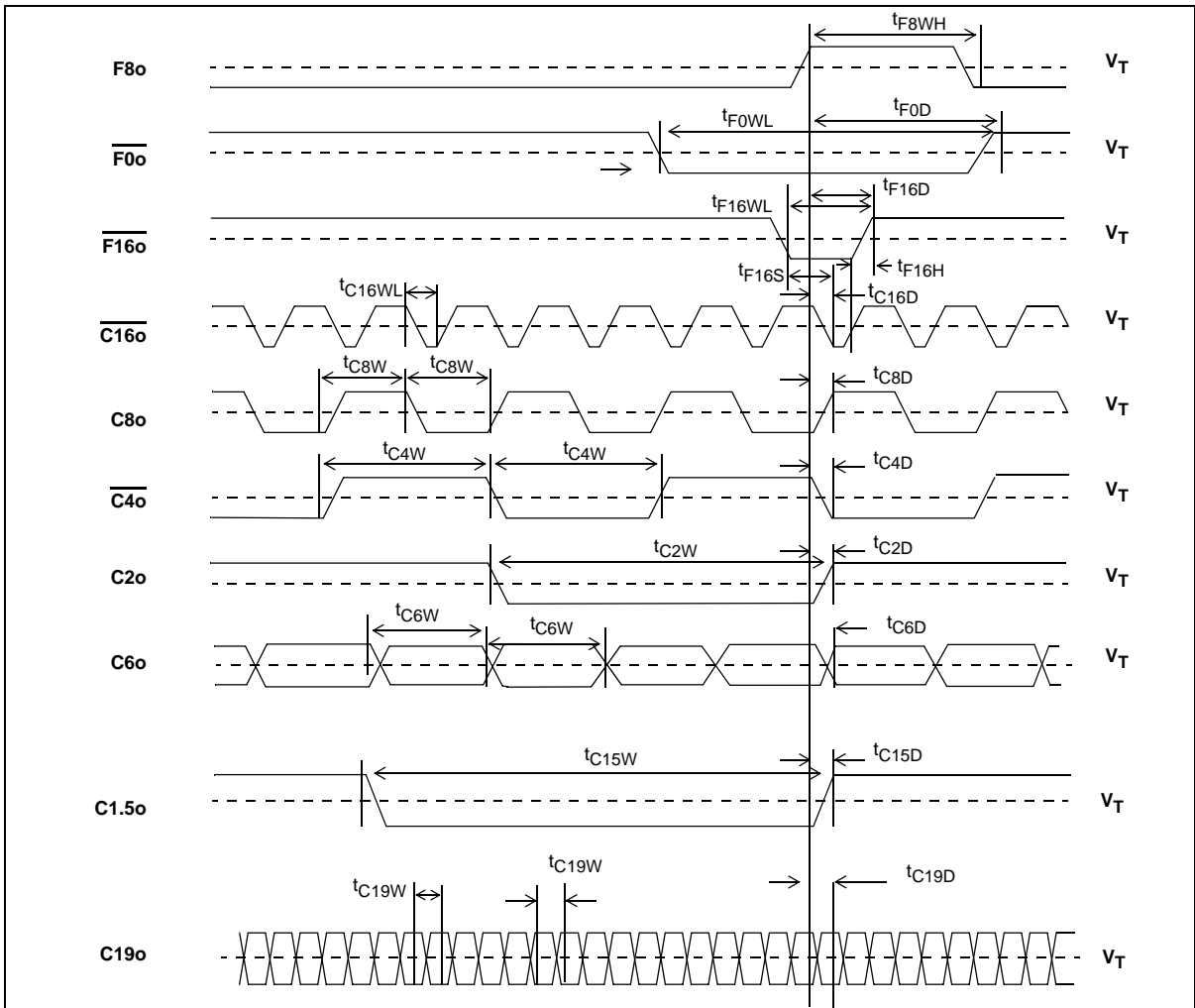

Figure 15 - Output Timing 1

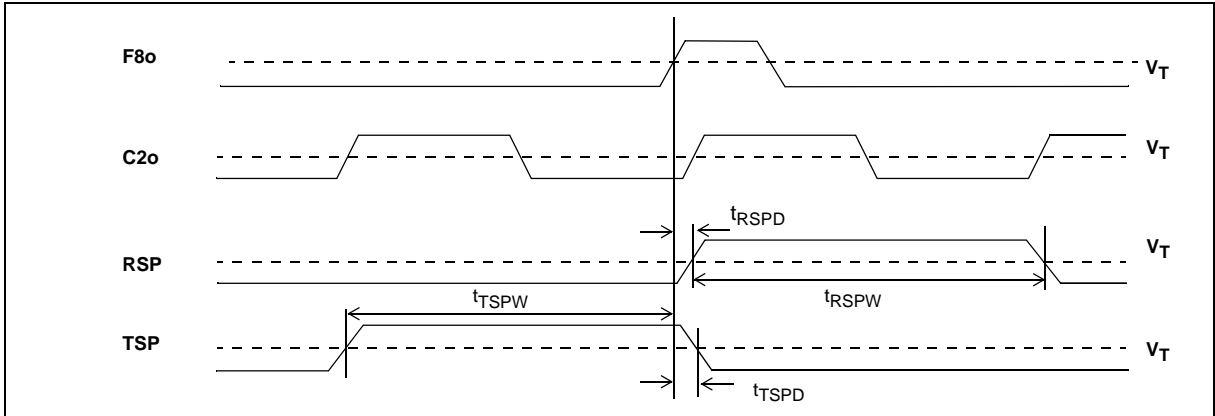

Figure 15 - Output Timing 2

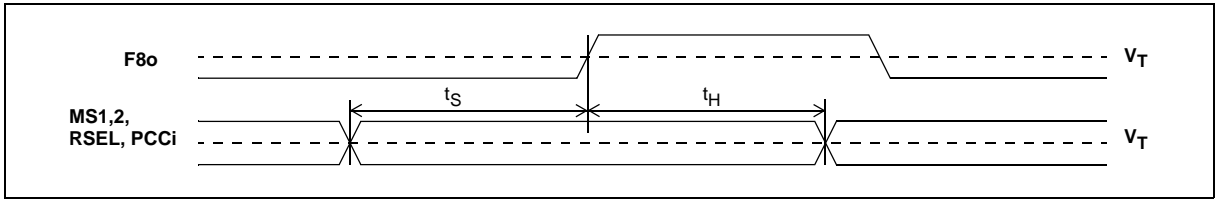

Figure 16 - Input Controls Setup and Hold Timing

AC Electrical Characteristics - Intrinsic Jitter Unfiltered

	Characteristics	Sym.	Max.	Units	Conditions/Notes†
1	Intrinsic jitter at F8o (8 kHz)		0.0002	U _{lpp}	1-15,22-25,29
2	Intrinsic jitter at $\overline{F0o}$ (8 kHz)		0.0002	U _{lpp}	1-15,22-25,29
3	Intrinsic jitter at $\overline{F16o}$ (8 kHz)		0.0002	U _{lpp}	1-15,22-25,29
4	Intrinsic jitter at C1.5o (1.544 MHz)		0.030	U _{lpp}	1-15,22-25,30
5	Intrinsic jitter at C2o (2.048 MHz)		0.040	U _{lpp}	1-15,22-25,31
6	Intrinsic jitter at C6o (6.312 MHz)		0.120	U _{lpp}	1-15,22-25,32
7	Intrinsic jitter at $\overline{C4o}$ (4.096 MHz)		0.080	U _{lpp}	1-15,22-25,33
8	Intrinsic jitter at C8o (8.192 MHz)		0.104	U _{lpp}	1-15,22-25,34
9	Intrinsic jitter at $\overline{C16o}$ (16.384 MHz)		0.104	U _{lpp}	1-15,22-25,35
10	Intrinsic jitter at TSP (8 kHz)		0.0002	U _{lpp}	1-15,22-25,35
11	Intrinsic jitter at RSP (8 kHz)		0.0002	U _{lpp}	1-15,22-25,35
12	Intrinsic jitter at C19o (19.44 MHz)		0.27	U _{lpp}	1-15,22-25,36

† See "Notes" following AC Electrical Characteristics tables.

AC Electrical Characteristics - C1.5o (1.544 MHz) Intrinsic Jitter Filtered

	Characteristics	Sym.	Min.	Max.	Units	Conditions/Notes†
1	Intrinsic jitter (4 Hz to 100 kHz filter)			0.015	UIpp	1-15,22-25,30
2	Intrinsic jitter (10 Hz to 40 kHz filter)			0.010	UIpp	1-15,22-25,30
3	Intrinsic jitter (8 kHz to 40 kHz filter)			0.010	UIpp	1-15,22-25,30
4	Intrinsic jitter (10 Hz to 8 kHz filter)			0.005	UIpp	1-15,22-25,30

† See "Notes" following AC Electrical Characteristics tables.

AC Electrical Characteristics - C2o (2.048 MHz) Intrinsic Jitter Filtered

	Characteristics	Sym.	Min.	Max.	Units	Conditions/Notes†
1	Intrinsic jitter (4 Hz to 100 kHz filter)			0.015	UIpp	1-15,22-25,31
2	Intrinsic jitter (10 Hz to 40 kHz filter)			0.010	UIpp	1-15,22-25,31
3	Intrinsic jitter (8 kHz to 40 kHz filter)			0.010	UIpp	1-15,22-25,31
4	Intrinsic jitter (10 Hz to 8 kHz filter)			0.005	UIpp	1-15,22-25,31

† See "Notes" following AC Electrical Characteristics tables.

AC Electrical Characteristics - 8 kHz Input to 8 kHz Output Jitter Transfer

	Characteristics	Sym.	Min.	Max.	Units	Conditions/Notes†
1	Jitter attenuation for 1 Hz@0.01 UIpp input		0	6	dB	1-3, 6, 10 -15, 22-23, 25, 29, 37
2	Jitter attenuation for 1 Hz@0.54 UIpp input		6	16	dB	1-3,6,10 -15, 22-23, 25, 29, 37
3	Jitter attenuation for 10 Hz@0.10 UIpp input		12	22	dB	1-3, 6,10 -15, 22-23,25,29,37
4	Jitter attenuation for 60 Hz@0.10 UIpp input		28	38	dB	1-3,6,10-15, 22-23,25,29,37
5	Jitter attenuation for 300 Hz@0.10 UIpp input		42		dB	1-3,6,10 -15, 22-23,25,29,37
6	Jitter attenuation for 3600 Hz@0.005 UIpp input		45		dB	1-3,6,10 -15, 22-23,25,29,37

† See "Notes" following AC Electrical Characteristics tables.

AC Electrical Characteristics - 1.544 MHz Input to 1.544 MHz Output Jitter Transfer

	Characteristics	Sym.	Min.	Max.	Units	Conditions/Notes†
1	Jitter attenuation for 1 Hz@20 U _{Ipp} input		0	6	dB	1-3,7,10 -15, 22-23,25,30,37
2	Jitter attenuation for 1 Hz@104 U _{Ipp} input		6	16	dB	1-3,7,10 -15, 22-23,25,30,37
3	Jitter attenuation for 10 Hz@20 U _{Ipp} input		12	22	dB	1-3,7,10 -15, 22-23,25,30,37
4	Jitter attenuation for 60 Hz@20 U _{Ipp} input		28	38	dB	1-3,7,10 -15, 22-23,25,30,37
5	Jitter attenuation for 300 Hz@20 U _{Ipp} input		42		dB	1-3,7,10-15, 22-23,25,30,37
6	Jitter attenuation for 10 kHz@0.3 U _{Ipp} input		45		dB	1-3,7,10-15, 22-23,25,30,37
7	Jitter attenuation for 100 kHz@0.3 U _{Ipp} input		45		dB	1-3,7,10-15, 22-23,25,30,37

† See "Notes" following AC Electrical Characteristics tables.

AC Electrical Characteristics - 2.048 MHz Input to 2.048 MHz Output Jitter Transfer

	Characteristics	Sym.	Min.	Max.	Units	Conditions/Notes†
1	Jitter at output for 1 Hz@3.00 Ulpp input			2.9	Ulpp	1-3,8,10-15, 22-23,25,31,37
2	with 40 Hz to 100 kHz filter			0.09	Ulpp	1-3,8,10-15, 22-23,25,31,38
3	Jitter at output for 3 Hz@2.33 Ulpp input			1.3	Ulpp	1-3,8,10-15, 22-23,25,31,37
4	with 40 Hz to 100 kHz filter			0.10	Ulpp	1-3,8,10-15, 22-23,25,31,38
5	Jitter at output for 5 Hz@2.07 Ulpp input			0.80	Ulpp	1-3,8,10-15, 22-23,25,31,37
6	with 40 Hz to 100 kHz filter			0.10	Ulpp	1-3,8,10-15, 22-23,25,31,38
7	Jitter at output for 10 Hz@1.76 Ulpp input			0.40	Ulpp	1-3,8,10-15, 22-23,25,31,37
8	with 40 Hz to 100 kHz filter			0.10	Ulpp	1-3,8,10-15, 22-23,25,31,38
9	Jitter at output for 100 Hz@1.50 Ulpp input			0.06	Ulpp	1-3,8,10-15, 22-23,25,31,37
10	with 40 Hz to 100 kHz filter			0.05	Ulpp	1-3,8,10-15, 22-23,25,31,38
11	Jitter at output for 2400 Hz@1.50 Ulpp input			0.04	Ulpp	1-3,8,10-15, 22-23,25,31,37
12	with 40 Hz to 100 kHz filter			0.03	Ulpp	1-3,8,10-15, 22-23,25,31,38
13	Jitter at output for 100 kHz@0.20 Ulpp input			0.04	Ulpp	1-3,8,10-15, 22-23,25,31,37
14	with 40 Hz to 100 kHz filter			0.02	Ulpp	1-3,8,10-15, 22-23,25,31,36

† See "Notes" following AC Electrical Characteristics tables.

AC Electrical Characteristics - 8 kHz Input Jitter Tolerance

	Characteristics	Sym.	Min.	Max.	Units	Conditions/Notes†
1	Jitter tolerance for 1 Hz input		0.80		Ulpp	1-3,6,10 -15,22-23,25-27,29
2	Jitter tolerance for 5 Hz input		0.70		Ulpp	1-3,6,10 -15,22-23,25-27,29
3	Jitter tolerance for 20 Hz input		0.60		Ulpp	1-3,6,10 -15,22-23,25-27,29
4	Jitter tolerance for 300 Hz input		0.20		Ulpp	1-3,6,10 -15,22-23,25-27,29
5	Jitter tolerance for 400 Hz input		0.15		Ulpp	1-3,6,10 -15,22-23,25-27,29
6	Jitter tolerance for 700 Hz input		0.08		Ulpp	1-3,6,10 -15,22-23,25-27,29
7	Jitter tolerance for 2400 Hz input		0.02		Ulpp	1-3,6,10 -15,22-23,25-27,29
8	Jitter tolerance for 3600 Hz input		0.01		Ulpp	1-3,6,10 -15,22-23,25-27,29

† See "Notes" following AC Electrical Characteristics tables.

AC Electrical Characteristics - 1.544 MHz Input Jitter Tolerance

	Characteristics	Sym.	Min.	Max.	Units	Conditions/Notes†
1	Jitter tolerance for 1 Hz input		150		Ulpp	1-3,7,10 -15,22-23,25-27,30
2	Jitter tolerance for 5 Hz input		140		Ulpp	1-3,7,10 -15,22-23,25-27,30
3	Jitter tolerance for 20 Hz input		130		Ulpp	1-3,7,10 -15,22-23,25-27,30
4	Jitter tolerance for 300 Hz input		35		Ulpp	1-3,7,10 -15,22-23,25-27,30
5	Jitter tolerance for 400 Hz input		25		Ulpp	1-3,7,10 -15,22-23,25-27,30
6	Jitter tolerance for 700 Hz input		15		Ulpp	1-3,7,10 -15,22-23,25-27,30
7	Jitter tolerance for 2400 Hz input		4		Ulpp	1-3,7,10 -15,22-23,25-27,30
8	Jitter tolerance for 10 kHz input		1		Ulpp	1-3,7,10 -15,22-23,25-27,30
9	Jitter tolerance for 100 kHz input		0.5		Ulpp	1-3,7,10 -15,22-23,25-27,30

† See "Notes" following AC Electrical Characteristics tables.

AC Electrical Characteristics - 2.048 MHz Input Jitter Tolerance

	Characteristics	Sym.	Min.	Max.	Units	Conditions/Notes†
1	Jitter tolerance for 1 Hz input		150		Ulpp	1-3,8,10 -15,22-23,25-27,31
2	Jitter tolerance for 5 Hz input		140		Ulpp	1-3,8,10 -15,22-23,25-27,31
3	Jitter tolerance for 20 Hz input		130		Ulpp	1-3,8,10 -15,22-23,25-27,31
4	Jitter tolerance for 300 Hz input		50		Ulpp	1-3,8,10 -15,22-23,25-27,31
5	Jitter tolerance for 400 Hz input		40		Ulpp	1-3,8,10 -15,22-23,25-27,31
6	Jitter tolerance for 700 Hz input		20		Ulpp	1-3,8,10 -15,22-23,25-27,31
7	Jitter tolerance for 2400 Hz input		5		Ulpp	1-3,8,10 -15,22-23,25-27,31
8	Jitter tolerance for 10 kHz input		1		Ulpp	1-3,8,10 -15,22-23,25-27,31
9	Jitter tolerance for 100 kHz input		1		Ulpp	1-3,8,10 -15,22-23,25-27,31

† See "Notes" following AC Electrical Characteristics tables.

AC Electrical Characteristics - OSCi 20 MHz Master Clock Input

	Characteristics	Sym.	Min.	Max.	Units	Conditions/Notes†
1	Tolerance		-0	+0	ppm	16,19
2			-32	+32	ppm	17,20
3			-100	+100	ppm	18,21
4	Duty cycle		40	60	%	
5	Rise time			10	ns	
6	Fall time			10	ns	

† See "Notes" following AC Electrical Characteristics tables.

† Notes:

Voltages are with respect to ground (V_{SS}) unless otherwise stated.
 Supply voltage and operating temperature are as per Recommended Operating Conditions.
 Timing parameters are as per AC Electrical Characteristics - Timing Parameter Measurement Voltage Levels

1. PRI reference input selected.
2. SEC reference input selected.
3. Normal Mode selected.
4. Holdover Mode selected.
5. Freerun Mode selected.
6. 8kHz Frequency Mode selected.
7. 1.544 MHz Frequency Mode selected.
8. 2.048 MHz Frequency Mode selected.
9. 19.44 MHz Frequency Mode selected.
10. Master clock input OSCi at 20 MHz ± 0 ppm.
11. Master clock input OSCi at 20 MHz ± 32 ppm.
12. Master clock input OSCi at 20 MHz ± 100 ppm.
13. Selected reference input at ± 0 ppm.
14. Selected reference input at ± 32 ppm.
15. Selected reference input at ± 100 ppm.
16. For Freerun Mode of ± 0 ppm.
17. For Freerun Mode of ± 32 ppm.
18. For Freerun Mode of ± 100 ppm.
19. For capture range of ± 230 ppm.
20. For capture range of ± 198 ppm.
21. For capture range of ± 130 ppm.
22. 25 pF capacitive load.
23. OSCi Master Clock jitter is less than 2 nspp, or 0.04 Ulpp where 1 Ulpp=1/20 MHz.
24. Jitter on reference input is less than 7 nspp.
25. Applied jitter is sinusoidal.
26. Minimum applied input jitter magnitude to regain synchronization.
27. Loss of synchronization is obtained at slightly higher input jitter amplitudes.
28. Within 10 ms of the state, reference or input change.
29. 1 Ulpp = 125 us for 8 kHz signals.
30. 1 Ulpp = 648 ns for 1.544 MHz signals.
31. 1 Ulpp = 488 ns for 2.048 MHz signals.
32. 1 Ulpp = 323 ns for 3.088 MHz signals.
33. 1 Ulpp = 244 ns for 4.096 MHz signals.
34. 1 Ulpp = 122 ns for 8.192 MHz signals.
35. 1 Ulpp = 61 ns for 16.384 MHz signals.
36. 1 Ulpp = 51.44 ns for 19.44 MHz signals.
37. No filter.
38. 40 Hz to 100 kHz bandpass filter.
39. With respect to reference input signal frequency.
40. After a RST or TCLR.
41. Master clock duty cycle 40% to 60%.
42. Prior to Holdover Mode, device was in Normal Mode and phase locked.

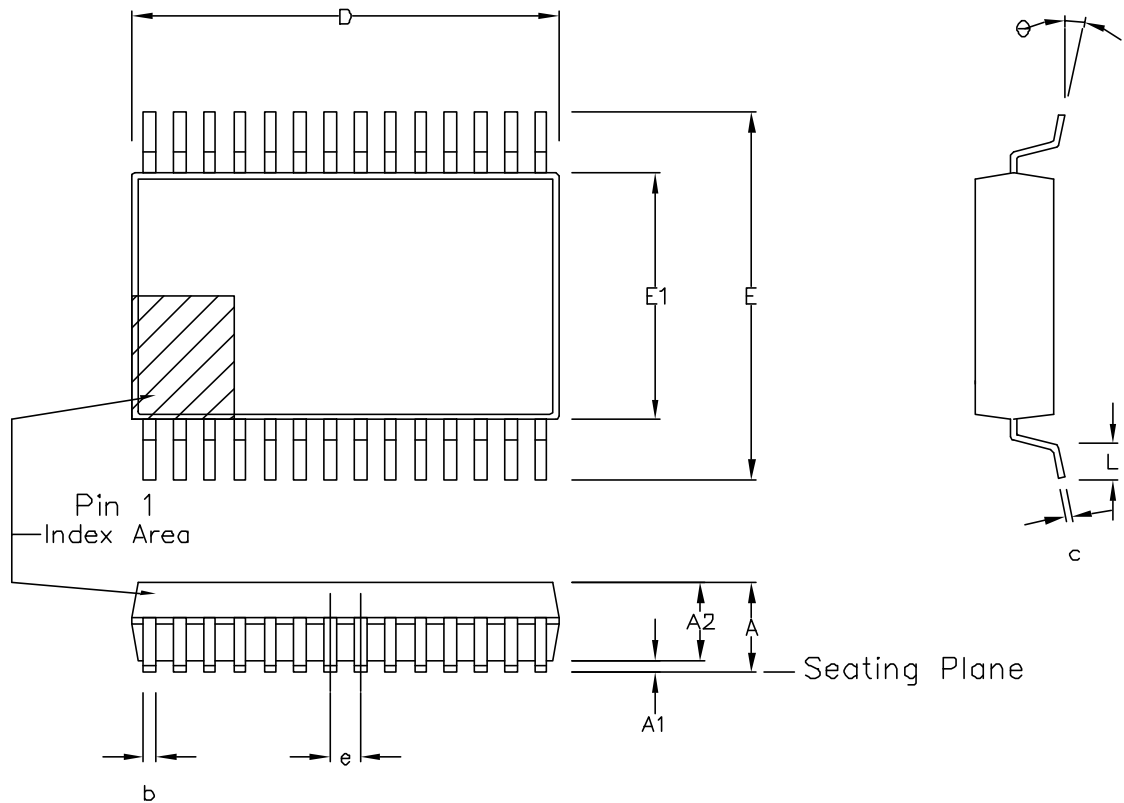

Symbol	Control Dimensions in millimetres			Altern. Dimensions in inches		
	MIN	Nominal	MAX	MIN	Nominal	MAX
A	2.41	2.59	2.79	0.095	0.102	0.110
A1	0.20	0.30	0.40	0.008	0.012	0.016
A2	2.26	2.39	2.52	0.089	0.094	0.099
D	15.75	15.88	16.00	0.620	0.625	0.630
E	10.03	10.31	10.67	0.395	0.406	0.420
E1	7.39	7.49	7.59	0.291	0.295	0.299
L	0.51	0.76	1.02	0.020	0.030	0.040
e	0.64 BSC.			0.025 BSC.		
b	0.20	0.25	0.34	0.008	0.010	0.0135
c	0.13	0.20	0.25	0.005	0.008	0.010
θ	0°		8°	0°		8°
Pin features						
N	48					
Conforms to JEDEC MO-118 AA Iss. A						

Notes:

1. A visual index feature, e.g. a dot, must be located within the cross-hatched area.
2. Controlling dimension are in millimeters.
3. Dimensions D and $E1$ do not include mould flash or protrusion. Mould flash or protrusion shall not exceed 0.15 mm per side. D and $E1$ are maximum plastic body size dimensions including mould mismatch.

© Zarlink Semiconductor 2003 All rights reserved.					Package Code	DD
ISSUE	1				Previous package codes	NP / N
ACN	213915				Package Outline for 48 lead SSOP (300 mil Body Width)	
DATE	13-01-03				GPD00816	
APPRD.						



**For more information about all Zarlink products
visit our Web Site at
www.zarlink.com**

Information relating to products and services furnished herein by Zarlink Semiconductor Inc. or its subsidiaries (collectively "Zarlink") is believed to be reliable. However, Zarlink assumes no liability for errors that may appear in this publication, or for liability otherwise arising from the application or use of any such information, product or service or for any infringement of patents or other intellectual property rights owned by third parties which may result from such application or use. Neither the supply of such information or purchase of product or service conveys any license, either express or implied, under patents or other intellectual property rights owned by Zarlink or licensed from third parties by Zarlink, whatsoever. Purchasers of products are also hereby notified that the use of product in certain ways or in combination with Zarlink, or non-Zarlink furnished goods or services may infringe patents or other intellectual property rights owned by Zarlink.

This publication is issued to provide information only and (unless agreed by Zarlink in writing) may not be used, applied or reproduced for any purpose nor form part of any order or contract nor to be regarded as a representation relating to the products or services concerned. The products, their specifications, services and other information appearing in this publication are subject to change by Zarlink without notice. No warranty or guarantee express or implied is made regarding the capability, performance or suitability of any product or service. Information concerning possible methods of use is provided as a guide only and does not constitute any guarantee that such methods of use will be satisfactory in a specific piece of equipment. It is the user's responsibility to fully determine the performance and suitability of any equipment using such information and to ensure that any publication or data used is up to date and has not been superseded. Manufacturing does not necessarily include testing of all functions or parameters. These products are not suitable for use in any medical products whose failure to perform may result in significant injury or death to the user. All products and materials are sold and services provided subject to Zarlink's conditions of sale which are available on request.

Purchase of Zarlink's I²C components conveys a licence under the Philips I²C Patent rights to use these components in and I²C System, provided that the system conforms to the I²C Standard Specification as defined by Philips.

Zarlink, ZL and the Zarlink Semiconductor logo are trademarks of Zarlink Semiconductor Inc.

Copyright Zarlink Semiconductor Inc. All Rights Reserved.

TECHNICAL DOCUMENTATION - NOT FOR RESALE
