

The SP8904 is one of a range of very high speed low power prescalers for professional applications. The dividing elements are static D type flip flops and therefore allow operation down to DC if the drive signal is a pulse waveform with fast risetime. The output stage has a differential current output and provides a direct drive into a 50 ohm load.

Ordering Information
 SP8904/KG/MP1S (tubes)
 SP8904/KG/MP1T (tape and reel)

Features

- Very High Operating Speed
- Operation down to DC with Square Wave Input
- Silicon Technology for Low Phase Noise
(Typically better than -140dBc/Hz at 1KHz)
- 5V Single Supply Operation
- Low Power Dissipation: 350mW (Typ.)
- Surface Mount Plastic Package

Absolute Maximum Ratings

Supply voltage, V_{CC}	6.5V
Storage temperature	-65°C to $+150^{\circ}\text{C}$
Maximum junction temperature	$+150^{\circ}\text{C}$
Prescaler input voltage	$2.5\text{V}_{\text{p-p}}$
Operating temperature	KG -40°C to $+85^{\circ}\text{C}$ T_{CASE}

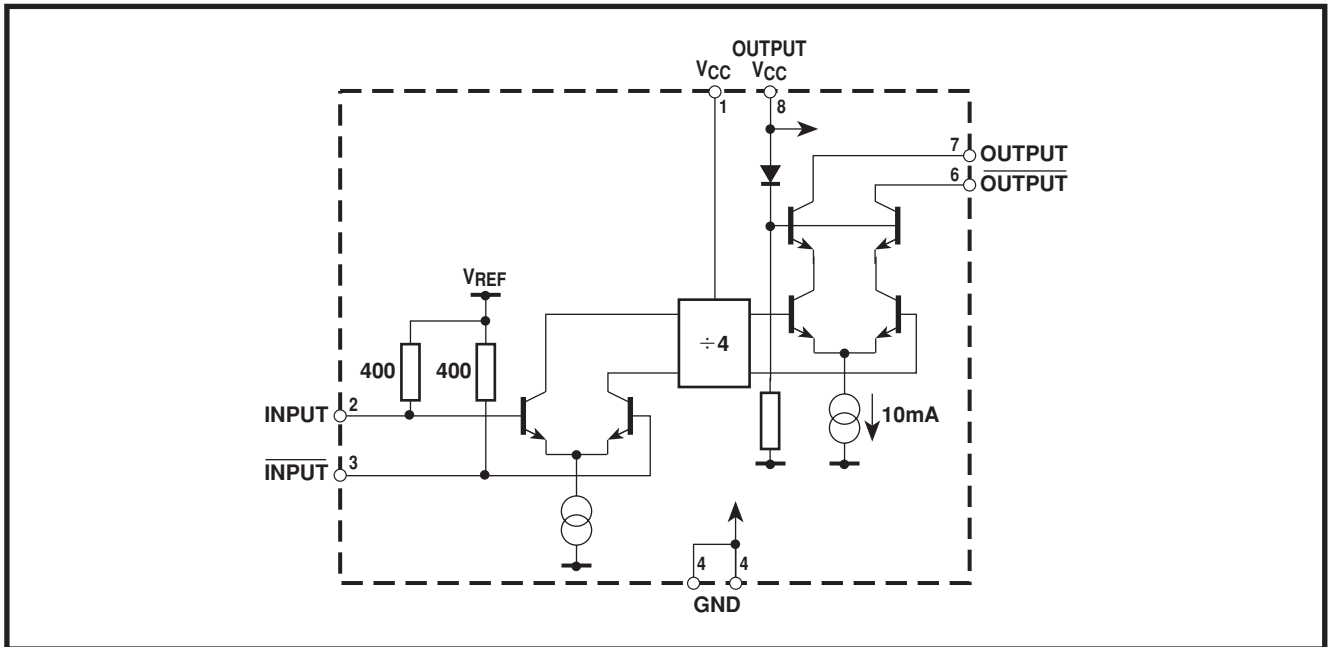

Figure 1 block diagram

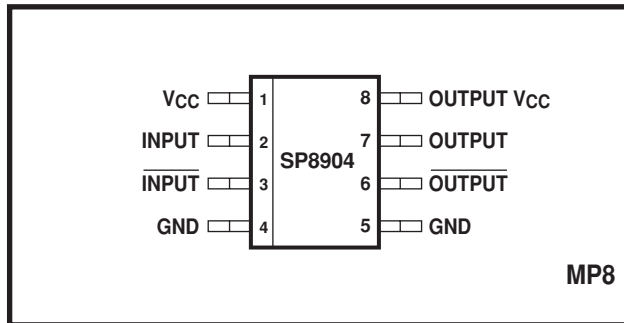

Figure 2 Pin connections - top view

Electrical Characteristics

These characteristics are guaranteed by either production test or design over the following range of operating conditions unless otherwise stated: $T_{AMB} = -40^{\circ}\text{C}$ to $+85^{\circ}\text{C}$, $V_{CC} = 4.75\text{V}$ to 5.25V

Characteristic	Pin	Value			Units	Conditions
		Min.	Typ.	Max.		
Supply current	1, 8	-	70	95	mA	
Input frequency	2, 3	1.0	-	5.0	GHz	RMS sinewave
Input sensitivity	2, 3	-	-	180	mVrms	$f_{IN} = 1\text{GHz}$ and 4.2GHz
Input sensitivity	2, 3	-	-	570	mVrms	$f_{IN} = 5\text{GHz}$
Input overload	2, 3	440	-	-	mVrms	$f_{IN} = 1\text{GHz}$ and 3GHz
Input overload	2, 3	700	-	-	mVrms	$f_{IN} = 5.0\text{GHz}$ and 3.8GHz
Output voltage	6, 7	-	0.5	-	Vp-p	Into 50Ω pullup resistor
Output power	6, 7	-10.0	0	+2.0	dBm	$f_{IN} = 1\text{GHz}$ and 5GHz (see note 1)

NOTE

1. Measured into 50Ω measuring instrument in parallel with 50Ω pullup resistor. See Figure 5.

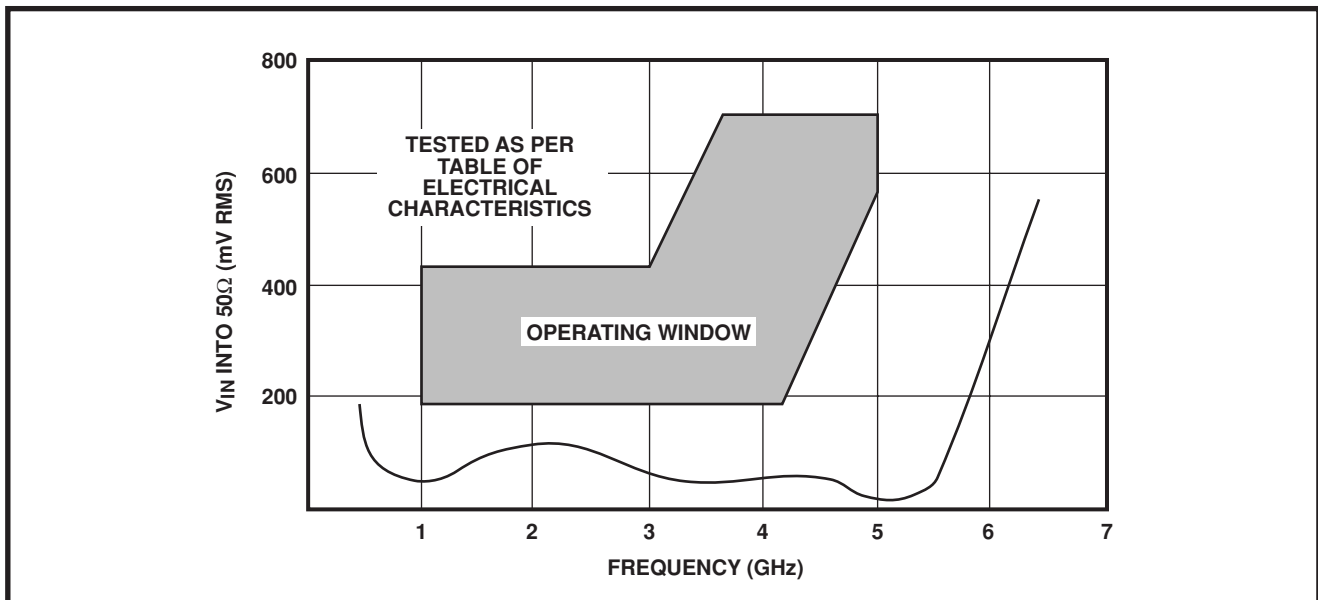

Figure3 Typical input sensitivity (sinewave drive)

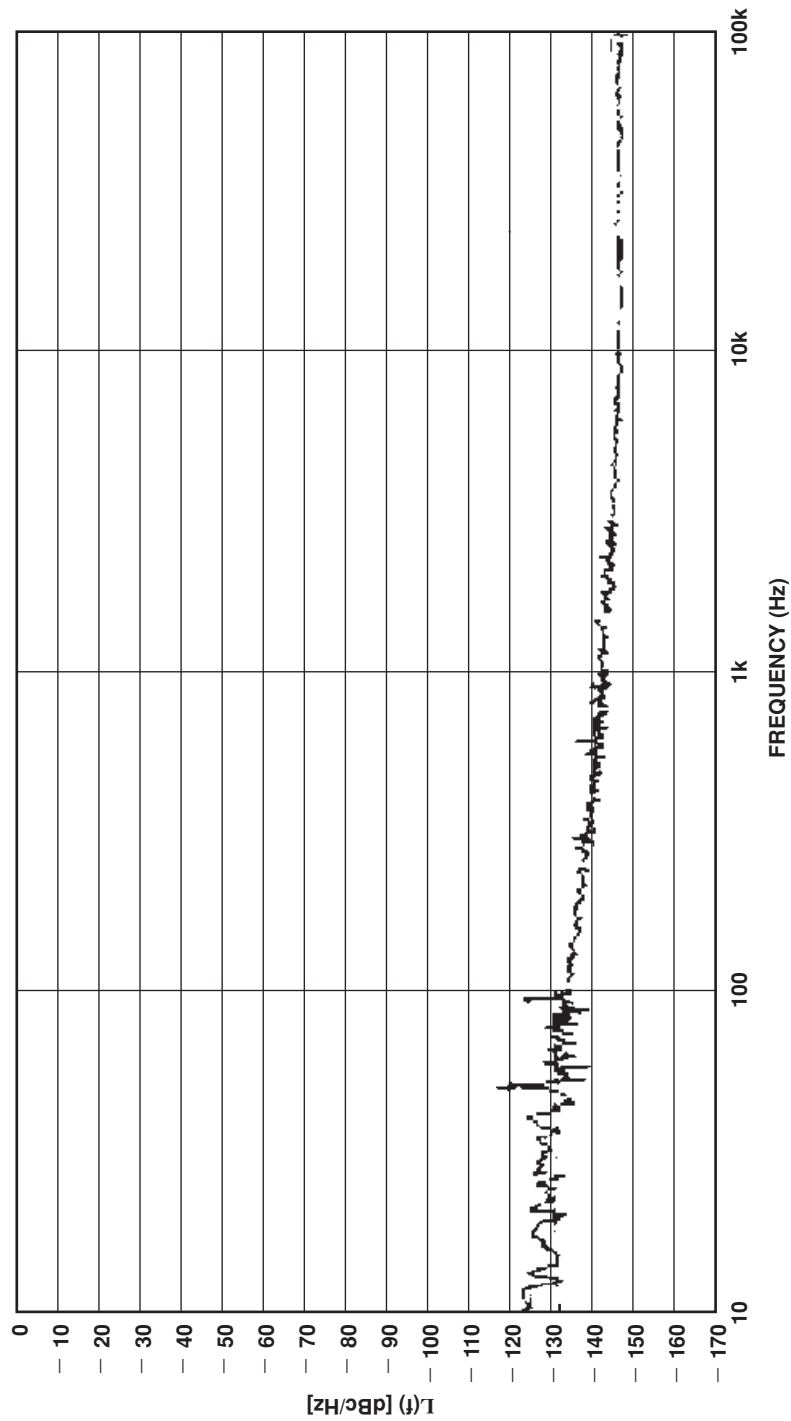
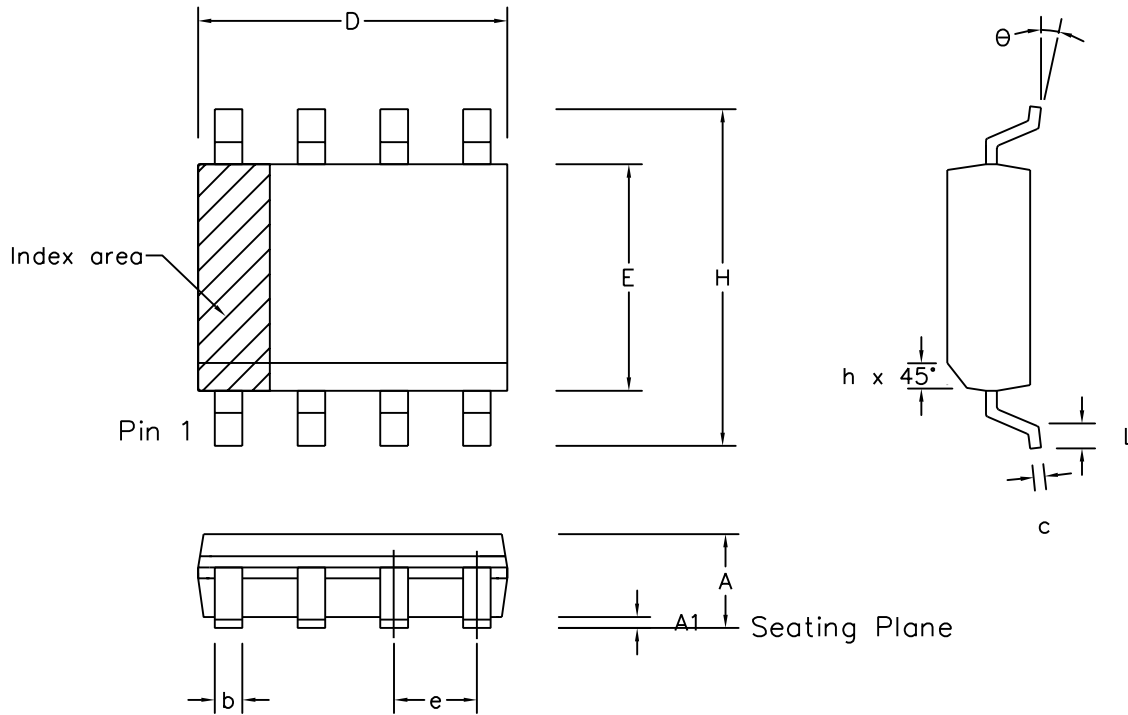

Figure 6 Typical phase noise, input frequency = 3GHz



	Min mm	Max mm	Min inch	Max inch
A	1.35	1.75	0.053	0.069
A1	0.10	0.25	0.004	0.010
D	4.80	5.00	0.189	0.197
H	5.80	6.20	0.228	0.244
E	3.80	4.00	0.150	0.157
L	0.40	1.27	0.016	0.050
e	1.27 BSC		0.050 BSC	
b	0.33	0.51	0.013	0.020
c	0.19	0.25	0.008	0.010
O	0°	8°	0°	8°
h	0.25	0.50	0.010	0.020
Pin Features				
N	8		8	
Conforms to JEDEC MS-012AA Iss. C				

Notes:

1. The chamfer on the body is optional. If not present, a visual index feature, e.g. a dot, must be located within the cross-hatched area.
2. Controlling dimensions are in inches.
3. Dimension D do not include mould flash, protusion or gate burrs. These shall not exceed 0.006" per side.
4. Dimension E1 do not include inter-lead flash or protusion. These shall not exceed 0.010" per side.
5. Dimension b does not include dambar protusion / intrusion. Allowable dambar protusion shall be 0.004" total in excess of b dimension.

© Zarlink Semiconductor 2002 All rights reserved.							Package Code DC
ISSUE	1	2	3	4	5		Previous package codes
ACN	6745	201936	202595	203705	212424		MP / S
DATE	5Apr95	27Feb97	12Jun97	9Dec97	22Mar02		Package Outline for 8 lead SOIC (0.150" Body width)
APPRD.							GPD00010



**For more information about all Zarlink products
visit our Web Site at
www.zarlink.com**

Information relating to products and services furnished herein by Zarlink Semiconductor Inc. or its subsidiaries (collectively "Zarlink") is believed to be reliable. However, Zarlink assumes no liability for errors that may appear in this publication, or for liability otherwise arising from the application or use of any such information, product or service or for any infringement of patents or other intellectual property rights owned by third parties which may result from such application or use. Neither the supply of such information or purchase of product or service conveys any license, either express or implied, under patents or other intellectual property rights owned by Zarlink or licensed from third parties by Zarlink, whatsoever. Purchasers of products are also hereby notified that the use of product in certain ways or in combination with Zarlink, or non-Zarlink furnished goods or services may infringe patents or other intellectual property rights owned by Zarlink.

This publication is issued to provide information only and (unless agreed by Zarlink in writing) may not be used, applied or reproduced for any purpose nor form part of any order or contract nor to be regarded as a representation relating to the products or services concerned. The products, their specifications, services and other information appearing in this publication are subject to change by Zarlink without notice. No warranty or guarantee express or implied is made regarding the capability, performance or suitability of any product or service. Information concerning possible methods of use is provided as a guide only and does not constitute any guarantee that such methods of use will be satisfactory in a specific piece of equipment. It is the user's responsibility to fully determine the performance and suitability of any equipment using such information and to ensure that any publication or data used is up to date and has not been superseded. Manufacturing does not necessarily include testing of all functions or parameters. These products are not suitable for use in any medical products whose failure to perform may result in significant injury or death to the user. All products and materials are sold and services provided subject to Zarlink's conditions of sale which are available on request.

Purchase of Zarlink's I²C components conveys a licence under the Philips I²C Patent rights to use these components in and I²C System, provided that the system conforms to the I²C Standard Specification as defined by Philips.

Zarlink, ZL and the Zarlink Semiconductor logo are trademarks of Zarlink Semiconductor Inc.

Copyright Zarlink Semiconductor Inc. All Rights Reserved.

TECHNICAL DOCUMENTATION - NOT FOR RESALE
