

October 2004

## Features

- 1024 channel x 1024 channel non-blocking digital Time Division Multiplex (TDM) switch at 4.096, 8.192 or 16.384 Mbps
- 16 serial TDM input, 16 serial TDM output streams
- Output streams can be configured as bi-directional for connection to backplanes
- Exceptional input clock cycle to cycle variation tolerance (20 ns for all rates)
- Per-stream input bit delay with flexible sampling point selection
- Per-stream output bit and fractional bit advancement
- Per-channel constant or variable throughput delay for frame integrity and low latency applications
- Per-channel high impedance output control
- Per-channel message mode
- Input clock: 4.096 MHz, 8.192 MHz, 16.384 MHz
- Input frame pulses: 61 ns, 122 ns, 244 ns
- Control interface compatible with Intel and Motorola 16-bit non-multiplexed buses

## Ordering Information

ZL50017GAC 256-ball PBGA  
 ZL50017QCC 256-lead LQFP  
**-40°C to +85°C**

- Connection memory block programming
- Supports ST-BUS and GCI-Bus standards for input and output timing
- IEEE-1149.1 (JTAG) test port
- 3.3 V I/O with 5 V tolerant inputs; 1.8 V core voltage

## Applications

- PBX and IP-PBX
- Small and medium digital switching platforms
- Remote access servers and concentrators
- Wireless base stations and controllers
- Multi service access platforms
- Digital Loop Carriers
- Computer Telephony Integration

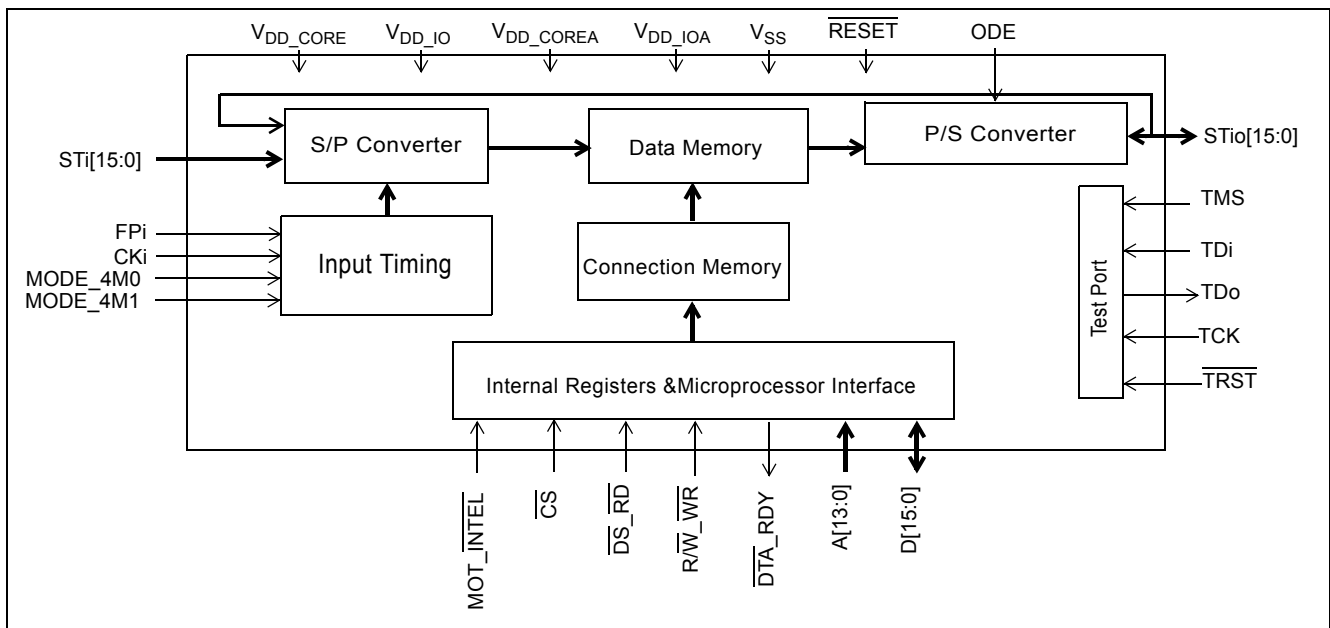

**Figure 1 - ZL50017 Functional Block Diagram**

## Description

The ZL50017 is a maximum 1024 x 1024 channel non-blocking digital Time Division Multiplex (TDM) switch. It has sixteen input streams (STi0 - 15) and sixteen output streams (STio0 - 15). The device can switch 64 kbps and Nx64 kbps TDM channels from any input stream to any output stream. All of the input and output streams operate at the same data rate and can be programmed at any of the following data rates: 2.048 Mbps, 4.096 Mbps, 8.192 Mbps or 16.384 Mbps. The output streams can be configured to operate in bi-directional mode, in which case STi0 - 15 will be ignored.

The device contains two types of internal memory - data memory and connection memory. There are three modes of operation - Connection Mode, Message Mode and high impedance mode. In Connection Mode, the contents of the connection memory define, for each output stream and channel, the source stream and channel (the actual data to be output is stored in the data memory). In Message Mode, the connection memory is used for the storage of microprocessor data. Using Zarlink's Message Mode capability, microprocessor data can be broadcast to the data output streams on a per-channel basis. This feature is useful for transferring control and status information for external circuits or other TDM devices. In high impedance mode the selected output channel can be put into a high impedance state.

The configurable non-multiplexed microprocessor port allows users to program various device operating modes and switching configurations. Users can employ the microprocessor port to perform register read/write, connection memory read/write and data memory read operations. The port is configurable to interface with either Motorola or Intel-type microprocessors.

The device also supports the mandatory requirements of the IEEE-1149.1 (JTAG) standard via the test port.

## Table of Contents

<b>1.0 Changes Summary</b> .....	<b>6</b>
<b>2.0 Pinout Diagrams</b> .....	<b>7</b>
2.1 BGA Pinout .....	7
2.2 QFP Pinout .....	8
<b>3.0 Pin Description</b> .....	<b>9</b>
<b>4.0 Device Overview</b> .....	<b>14</b>
<b>5.0 Data Rates and Timing</b> .....	<b>14</b>
5.1 Input Clock (CKi) and Input Frame Pulse (FPi) Timing .....	15
5.2 ST-BUS and GCI-Bus Timing .....	17
<b>6.0 Data Input Delay and Data Output Advancement</b> .....	<b>17</b>
6.1 Input Bit Delay Programming .....	18
6.2 Input Bit Sampling Point Programming .....	19
6.3 Output Advancement Programming .....	20
6.4 Fractional Output Bit Advancement Programming .....	21
<b>7.0 Data Delay Through the Switching Paths</b> .....	<b>22</b>
7.1 Variable Delay Mode .....	22
7.2 Constant Delay Mode .....	23
<b>8.0 Connection Memory Description</b> .....	<b>23</b>
<b>9.0 Connection Memory Block Programming</b> .....	<b>24</b>
9.1 Memory Block Programming Procedure .....	24
<b>10.0 Microprocessor Port</b> .....	<b>24</b>
<b>11.0 Device Reset and Initialization</b> .....	<b>25</b>
11.1 Power-up Sequence .....	25
11.2 Device Initialization on Reset .....	25
11.3 Software Reset .....	25
<b>12.0 JTAG Port</b> .....	<b>25</b>
12.1 Test Access Port (TAP) .....	25
12.2 Instruction Register .....	26
12.3 Test Data Registers .....	26
12.4 BSDL .....	26
<b>13.0 Register Address Mapping</b> .....	<b>27</b>
<b>14.0 Detailed Register Description</b> .....	<b>28</b>
<b>15.0 Memory</b> .....	<b>34</b>
15.1 Memory Address Mappings .....	34
15.2 Connection Memory Low (CM_L) Bit Assignment .....	35
<b>16.0 DC Parameters</b> .....	<b>37</b>
<b>17.0 AC Parameters</b> .....	<b>38</b>

## List of Figures

Figure 1 - ZL50017 Functional Block Diagram	1
Figure 2 - ZL50017 256-Ball 17 mm x 17 mm PBGA (as viewed through top of package)	7
Figure 3 - ZL50017 256-Lead 28 mm x 28 mm LQFP (top view)	8
Figure 4 - Input Timing when CKIN1 - 0 bits = "10" in the CR	16
Figure 5 - Input Timing when CKIN1 - 0 bits = "01" in the CR	16
Figure 6 - Input Timing when CKIN1 - 0 = "00" in the CR	17
Figure 7 - Input Bit Delay Timing Diagram (ST-BUS)	18
Figure 8 - Input Bit Sampling Point Programming	19
Figure 9 - Input Bit Delay and Fractional Sampling Point	20
Figure 10 - Output Bit Advancement Timing Diagram (ST-BUS)	21
Figure 11 - Output Fractional Bit Advancement Timing Diagram (ST-BUS)	21
Figure 12 - Data Throughput Delay for Variable Delay	22
Figure 13 - Data Throughput Delay for Constant Delay	23
Figure 14 - Timing Parameter Measurement Voltage Levels	38
Figure 15 - Motorola Non-Multiplexed Bus Timing - Read Access	39
Figure 16 - Motorola Non-Multiplexed Bus Timing - Write Access	40
Figure 17 - Intel Non-Multiplexed Bus Timing - Read Access	41
Figure 18 - Intel Non-Multiplexed Bus Timing - Write Access	42
Figure 19 - JTAG Test Port Timing Diagram	43
Figure 20 - Frame Pulse Input and Clock Input Timing Diagram (ST-BUS)	45
Figure 21 - Frame Pulse Input and Clock Input Timing Diagram (GCI-Bus)	45
Figure 22 - ST-BUS Input and Output Timing Diagram when Operated at 2, 4, 8 and 16 Mbps	47
Figure 23 - GCI-Bus Input and Output Timing Diagram when Operated at 2, 4, 8 and 16 Mbps	48

---

## List of Tables

Table 1 - CKi and FPi Configurations . . . . .	15
Table 2 - Delay for Variable Delay Mode . . . . .	22
Table 3 - Connection Memory Low After Block Programming . . . . .	24
Table 4 - Address Map for Registers (A13 = 0) . . . . .	27
Table 5 - Control Register (CR) Bits . . . . .	28
Table 6 - Internal Mode Selection Register (IMS) Bits . . . . .	30
Table 7 - Software Reset Register (SRR) Bits . . . . .	31
Table 8 - Data Rate Selection Register . . . . .	31
Table 9 - Internal Flag Register (IFR) Bits - Read Only . . . . .	32
Table 10 - Stream Input Control Register 0 - 15 (SICR0 - 15) Bits . . . . .	32
Table 11 - Stream Output Control Register 0 - 15 (SOCR0 - 15) Bits . . . . .	33
Table 12 - Address Map for Memory Locations (A13 = 1) . . . . .	34
Table 13 - Connection Memory Low (CM_L) Bit Assignment when CMM = 0 . . . . .	35
Table 14 - Connection Memory Low (CM_L) Bit Assignment when CMM = 1 . . . . .	36

## 1.0 Changes Summary

Page	Item	Change
7	Figure 2, "ZL50017 256-Ball 17 mm x 17 mm PBGA (as viewed through top of package)"	<ul style="list-style-type: none"> <li>• Re-labeled IC_OPEN to MODE_4M0 Location: Ball M14</li> <li>• Re-labeled IC_OPEN to MODE_4M1 Location: Ball R13</li> </ul>
8	Figure 3, "ZL50017 256-Lead 28 mm x 28 mm LQFP (top view)"	<ul style="list-style-type: none"> <li>• Re-labeled IC_OPEN to MODE_4M0 Location: Pin 46</li> <li>• Re-labeled IC_OPEN to MODE_4M1 Location: Pin 48</li> </ul>
9	3.0, "Pin Description"	<ul style="list-style-type: none"> <li>• Added MODE_4M0 &amp; MODE_4M1 descriptions</li> </ul>
27	13.0, "Register Address Mapping"	<ul style="list-style-type: none"> <li>• Added Reg 0010H to list</li> </ul>
28	14.0, "Detailed Register Description"	<ul style="list-style-type: none"> <li>• Changed Bits 6-5 Description - Added MODE 4M0/1 reference</li> </ul>

## 2.0 Pinout Diagrams

### 2.1 BGA Pinout

	1	2	3	4	5	6	7	8	9	10	11	12	13	14	15	16	
A	V <sub>SS</sub>	NC	NC	NC	NC	NC	NC	NC	NC	NC	NC	NC	NC	NC	NC	V <sub>SS</sub>	A
B	NC	STi10	STi5	STi4	NC	STi0	NC	NC	V <sub>DD_COREA</sub>	FPI	CKi	IC_Open	IC_Open	IC_GND	ODE	NC	B
C	NC	STi9	V <sub>SS</sub>	STi7	STi6	STi1	NC	NC	V <sub>SS</sub>	IC_Open	IC_Open	IC_Open	IC_GND	V <sub>SS</sub>	STi15	NC	C
D	NC	STi11	V <sub>DD_IO</sub>	STi3	STi2	NC	NC	NC	NC	V <sub>SS</sub>	NC	IC_GND	STi13	V <sub>DD_IO</sub>	STi14	NC	D
E	NC	STi14	STi8	V <sub>DD_IO</sub>	V <sub>SS</sub>	V <sub>DD_CORE</sub>	NC	NC	NC	NC	V <sub>DD_CORE</sub>	V <sub>SS</sub>	V <sub>DD_IO</sub>	STi12	NC	NC	E
F	NC	STi15	STi12	STi13	V <sub>DD_IO</sub>	V <sub>DD_CORE</sub>	V <sub>DD_CORE</sub>	V <sub>SS</sub>	V <sub>SS</sub>	V <sub>DD_CORE</sub>	V <sub>DD_CORE</sub>	V <sub>DD_IO</sub>	IC_Open	NC	NC	NC	F
G	NC	$\overline{\text{RESET}}$	IC_GND	IC_Open	TDo	V <sub>DD_IO</sub>	V <sub>SS</sub>	V <sub>SS</sub>	V <sub>SS</sub>	V <sub>SS</sub>	V <sub>DD_IO</sub>	A12	A13	NC	NC	NC	G
H	NC	V <sub>SS</sub>	V <sub>SS</sub>	V <sub>DD_COREA</sub>	NC	V <sub>SS</sub>	V <sub>SS</sub>	V <sub>SS</sub>	V <sub>SS</sub>	V <sub>SS</sub>	A7	A9	A10	NC	A11	NC	H
J	NC	V <sub>DD_IOA</sub>	V <sub>DD_IOA</sub>	V <sub>SS</sub>	V <sub>SS</sub>	NC	V <sub>SS</sub>	V <sub>SS</sub>	V <sub>SS</sub>	V <sub>SS</sub>	A3	A4	A5	A8	A6	NC	J
K	NC	V <sub>SS</sub>	TMS	V <sub>SS</sub>	V <sub>DD_COREA</sub>	V <sub>DD_IO</sub>	V <sub>SS</sub>	V <sub>SS</sub>	V <sub>SS</sub>	V <sub>SS</sub>	V <sub>DD_IO</sub>	IC_Open	A0	A2	A1	NC	K
L	NC	V <sub>DD_COREA</sub>	$\overline{\text{TRST}}$	TCK	V <sub>DD_IO</sub>	V <sub>DD_CORE</sub>	V <sub>DD_CORE</sub>	V <sub>SS</sub>	V <sub>SS</sub>	V <sub>DD_CORE</sub>	V <sub>DD_CORE</sub>	V <sub>DD_IO</sub>	STi10	STi11	STi9	NC	L
M	NC	NC	TDi	D0	V <sub>SS</sub>	V <sub>DD_CORE</sub>	V <sub>DD_CORE</sub>	D6	D10	V <sub>DD_CORE</sub>	V <sub>DD_CORE</sub>	V <sub>SS</sub>	$\overline{\text{MOT\_INTEL}}$	MODE_4M0	STi8	NC	M
N	NC	NC	V <sub>DD_IO</sub>	STi0	NC	D1	D5	D7	D11	D13	$\overline{\text{R/W\_WR}}$	$\overline{\text{DTA\_RDY}}$	STi4	V <sub>DD_IO</sub>	NC	NC	N
P	NC	NC	V <sub>SS</sub>	STi1	STi3	NC	D3	D8	D14	NC	STi5	NC	NC	V <sub>SS</sub>	NC	NC	P
R	NC	NC	NC	STi2	NC	D2	D4	D9	D12	D15	$\overline{\text{CS}}$	$\overline{\text{DS\_RD}}$	MODE_4M1	STi6	STi7	NC	R
T	V <sub>SS</sub>	NC	NC	NC	NC	NC	NC	NC	NC	NC	NC	NC	NC	NC	NC	V <sub>SS</sub>	T
	1	2	3	4	5	6	7	8	9	10	11	12	13	14	15	16	

**Note:** A1 corner identified by metallized marking.  
**Note:** Pinout is shown as viewed through top of package.

**Figure 2 - ZL50017 256-Ball 17 mm x 17 mm PBGA (as viewed through top of package)**

2.2 QFP Pinout

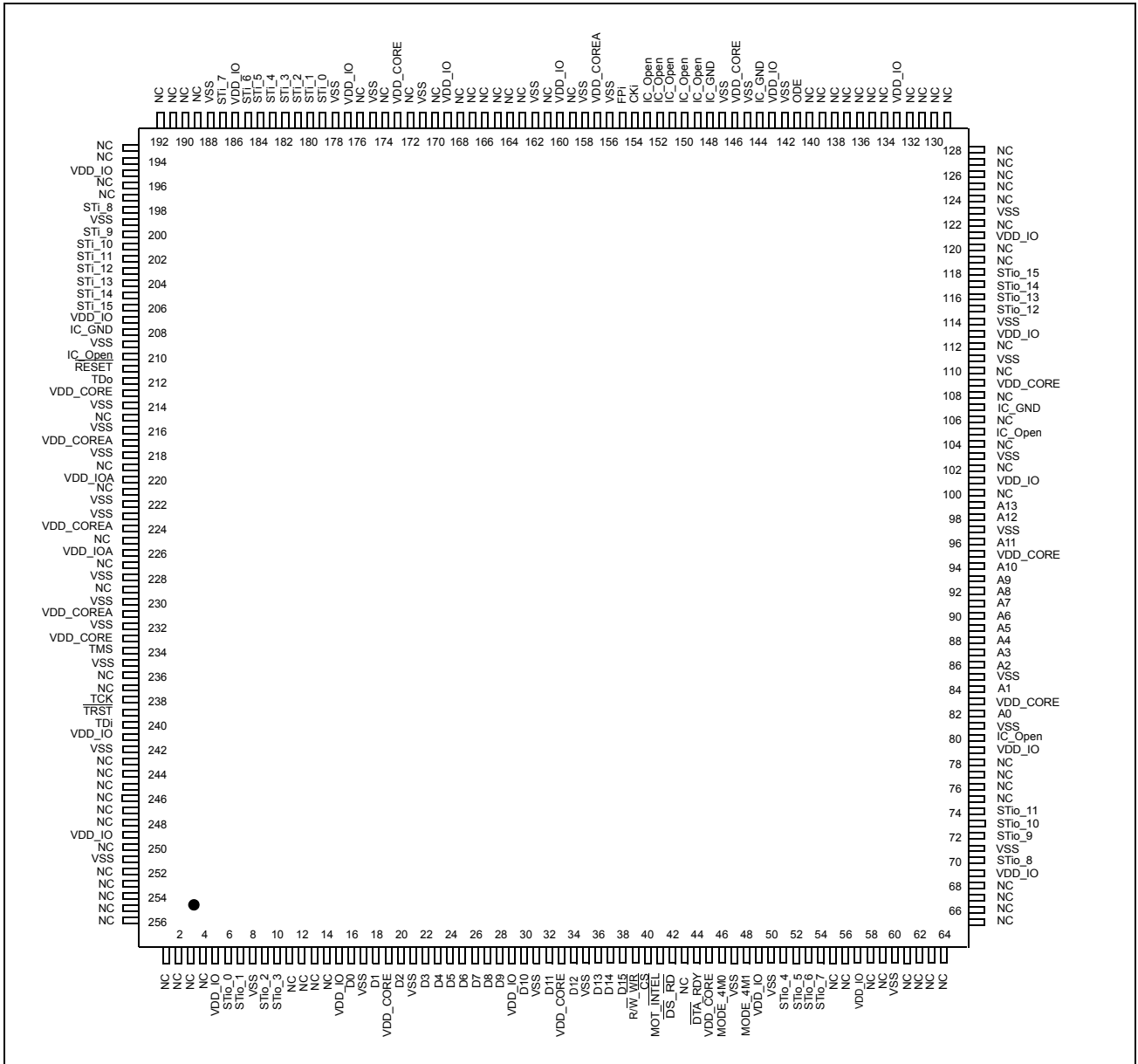

Figure 3 - ZL50017 256-Lead 28 mm x 28 mm LQFP (top view)

### 3.0 Pin Description

PBGA Pin Number	LQFP Pin Number	Pin Name	Description
E6, E11, F6, F7, F10, F11, L6, L7, L10, L11, M6, M7, M10, M11	19, 33, 45, 83, 95, 109, 146, 173, 213, 233	$V_{DD\_CORE}$	<b>Power Supply for the core logic: +1.8 V</b>
H4, K5, B9, L2	217, 231, 157, 224	$V_{DD\_COREA}$	<b>Power Supply for analog circuitry: +1.8 V</b>
D3, D14, E4, E13, F5, F12, G6, G11, K6, K11, L5, L12, N3, N14	5, 15, 29, 49, 57, 69, 79, 101, 113, 121, 133, 143, 160, 169, 177, 186, 195, 207, 241, 249	$V_{DD\_IO}$	<b>Power Supply for I/O: +3.3 V</b>
J2, J3	220, 226	$V_{DD\_IOA}$	<b>Power Supply for the CKo5 and CKo3 outputs: +3.3 V</b>
A1, A16, C3, C9, C14, D10, E5, E12, F8, F9, G7, G8, G9, G10, H2, H3, H6, H7, H8, H9, H10, J4, J5, J7, J8, J9, J10, K2, K4, K7, K8, K9, K10, L8, L9, M5, M12, P3, P14, T1, T16	8, 17, 21, 31, 35, 47, 50, 60, 71, 81, 85, 97, 103, 111, 114, 123, 142, 145, 147, 156, 158, 162, 171, 175, 178, 188, 199, 209, 214, 216, 218, 222, 223, 228, 230, 232, 235, 242, 251	$V_{SS}$	<b>Ground</b>

PBGA Pin Number	LQFP Pin Number	Pin Name	Description
K3	234	TMS	<b>Test Mode Select (5 V-Tolerant Input with Internal Pull-up)</b> JTAG signal that controls the state transitions of the TAP controller. This pin is pulled high by an internal pull-up resistor when it is not driven.
L4	238	TCK	<b>Test Clock (5 V-Tolerant Schmitt-Triggered Input with Internal Pull-up)</b> Provides the clock to the JTAG test logic.
L3	239	$\overline{\text{TRST}}$	<b>Test Reset (5 V-Tolerant Input with Internal Pull-up)</b> Asynchronously initializes the JTAG TAP controller by putting it in the Test-Logic-Reset state. This pin should be pulsed low during power-up to ensure that the device is in the normal functional mode. When JTAG is not being used, this pin should be pulled low during normal operation.
M3	240	TDi	<b>Test Serial Data In (5 V-Tolerant Input with Internal Pull-up)</b> JTAG serial test instructions and data are shifted in on this pin. This pin is pulled high by an internal pull-up resistor when it is not driven.
G5	212	TDo	<b>Test Serial Data Out (5 V-Tolerant Three-state Output)</b> JTAG serial data is output on this pin on the falling edge of TCK. This pin is held in high impedance state when JTAG is not enabled.
B12, B13, C10, C11, F13, G4, K12, C12,	80, 105, 150, 151, 152, 153, 210, 149	IC_Open	<b>Internal Test Mode (5 V-Tolerant Input with Internal Pull-down)</b> These pins may be left unconnected.
G3, D12, C13, B14	144, 107, 148, 208	IC_GND	<b>Internal Test Mode Enable (5 V-Tolerant Input)</b> These pins <b>MUST</b> be low.

PBGA Pin Number	LQFP Pin Number	Pin Name	Description
A8, A9, A14, A15, E10, M2, N2, P2, P16, R2, R16, T6, T7, T8, T9, T10, T11, T12, T13, T14, T15, D16, E16, C16, B16, A13, A12, A10, A11, N1, M1, P1, R1, T2, T3, T5, T4, N16, M16, L16, K16, H16, J16, G16, F16, D9, E8, C8, E7, D6, H5, P10, G15, G14, E15, F14, H14, D11, F15, B7, C7, B5, J6, R3, P6, R5, N5, P12, N15, P13, P15, E1, D1, G1, F1, J1, H1, K1, L1, A7, A5, A6, A4, A3, A2, C1, B1, E9, D8, B8, D7	61, 62, 63, 64, 65, 66, 67, 68, 134, 135, 136, 137, 138, 139, 140, 215, 219, 225, 229, 236, 237, 125, 126, 127, 128, 129, 130, 131, 132, 253, 254, 255, 256, 1, 2, 3, 4, 75, 76, 77, 78, 119, 120, 122, 124, 159, 163, 165, 167, 176, 221, 43, 102, 106, 110, 112, 100, 104, 108, 170, 172, 174, 227, 11, 12, 13, 14, 55, 56, 58, 59, 243, 244, 245, 246, 247, 248, 250, 252, 189, 190, 191, 192, 193, 194, 196, 197, 161, 164, 166, 168	NC	<b>No Connect</b> These pins <b>MUST</b> be left unconnected.

PBGA Pin Number	LQFP Pin Number	Pin Name	Description															
M14, R13	46, 48	MODE_4M0, MODE_4M1	<p><b>4 M Input Clock Mode 0 to 1 (5 V-Tolerant Input with internal pull-down)</b> These two pins should be tied together.</p> <table border="1"> <thead> <tr> <th>MODE_4M1</th> <th>MODE_4M0</th> <th>Operation</th> </tr> </thead> <tbody> <tr> <td>0</td> <td>0</td> <td>CKi = 8.192 MHz or 16.384 MHz</td> </tr> <tr> <td>1</td> <td>1</td> <td>CKi = 4.096 MHz</td> </tr> <tr> <td>0</td> <td>1</td> <td>Reserved</td> </tr> <tr> <td>1</td> <td>0</td> <td>Reserved</td> </tr> </tbody> </table> <p>See Table 5, "Control Register (CR) Bits" on page 28 for CKi and FPi selection using the CKIN1 - 0 bits.</p>	MODE_4M1	MODE_4M0	Operation	0	0	CKi = 8.192 MHz or 16.384 MHz	1	1	CKi = 4.096 MHz	0	1	Reserved	1	0	Reserved
MODE_4M1	MODE_4M0	Operation																
0	0	CKi = 8.192 MHz or 16.384 MHz																
1	1	CKi = 4.096 MHz																
0	1	Reserved																
1	0	Reserved																
B10	155	FPI	<p><b>ST-BUS/GCI-Bus Frame Pulse Input (5 V-Tolerant Schmitt-Triggered Input)</b></p> <p>This pin accepts the frame pulse which stays active for 61 ns, 122 ns or 244 ns at the frame boundary. The frame pulse frequency is 8 kHz. The frame pulse associated with the CKi must be applied to this pin. By default, the device accepts a negative frame pulse in ST-BUS format, but it can accept a positive frame pulse instead if the FPINP bit is set high in the Control Register (CR). It can accept a GCI-formatted frame pulse by programming the FPINPOS bit in the Control Register (CR) to high.</p>															
B11	154	CKi	<p><b>ST-BUS/GCI-Bus Clock Input (5 V-Tolerant Schmitt-Triggered Input)</b></p> <p>This pin accepts a 4.096 MHz, 8.192 MHz or 16.384 MHz clock. The clock frequency applied to this pin must be <b>twice the highest input or output</b> data rate. The exception is, when data is running at 16.384 Mbps, a 16.384 MHz clock must be used. By default, the clock falling edge defines the input frame boundary, but the device allows the clock rising edge to define the frame boundary by programming the CKINP bit in the Control Register (CR).</p>															
B6, C6, D5, D4, B4, B3, C5, C4, E3, C2, B2, D2, F3, F4, E2, F2	179, 180, 181, 182, 183, 184, 185, 187, 198, 200, 201, 202, 203, 204, 205, 206	STi0 - 15	<p><b>Serial Input Streams 0 to 15 (5 V-Tolerant Inputs with Internal Pull-downs)</b></p> <p>The data rate of all the input streams are programmed through the "Data Rate Selection Register" on page 31. In the 2.048 Mbps mode, these pins accept serial TDM data streams at 2.048 Mbps with 32 channels per frame. In the 4.096 Mbps mode, these pins accept serial TDM data streams at 4.096 Mbps with 64 channels per frame. In the 8.192 Mbps mode, these pins accept serial TDM data streams at 8.192 Mbps with 128 channels per frame. In the 16.384 Mbps mode, these pins accept serial TDM data streams at 16.384 Mbps with 256 channels per frame.</p>															

PBGA Pin Number	LQFP Pin Number	Pin Name	Description
N4, P4, R4, P5, N13, P11, R14, R15, M15, L15, L13, L14, E14, D13, D15, C15	6, 7, 9, 10, 51, 52, 53, 54, 70, 72, 73, 74, 115, 116, 117, 118	STio 0 - 15	<b>Serial Output Streams 0 to 15 (5 V-Tolerant Slew-Rate-Limited Three-state I/Os with Enabled Internal Pull-downs)</b> The data rate of all the output streams are programmed through the "Data Rate Selection Register" on page 31. In the 2.048 Mbps mode, these pins output serial TDM data streams at 2.048 Mbps with 32 channels per frame. In the 4.096 Mbps mode, these pins output serial TDM data streams at 4.096 Mbps with 64 channels per frame. In the 8.192 Mbps mode, these pins output serial TDM data streams at 8.192 Mbps with 128 channels per frame. In the 16.384 Mbps mode, these pins output serial TDM data streams at 16.384 Mbps with 256 channels per frame. These output streams can be used as bi-directionals by programming BDH (bit 7) and BDL (bit 6) of Internal Mode Selection (IMS) register.
B15	141	ODE	<b>Output Drive Enable (5 V-Tolerant Input with Internal Pull-up)</b> This is the output enable control for STio0 - 15. When it is high, STio0 - 15 are enabled. When it is low, STio0 - 15 are tristated.
M4, N6, R6, P7, R7, N7, M8, N8, P8, R8, M9, N9, R9, N10, P9, R10	16, 18, 20, 22, 23, 24, 25, 26, 27, 28, 30, 32, 34, 36, 37, 38	D0 - 15	<b>Data Bus 0 to 15 (5 V-Tolerant Slew-Rate-Limited Three-state I/Os)</b> These pins form the 16-bit data bus of the microprocessor port.
N12	44	$\overline{\text{DTA\_RDY}}$	<b>Data Transfer Acknowledgment_Ready (5 V-Tolerant Three-state Output)</b> This active low output indicates that a data bus transfer is complete for the Motorola interface. For the Intel interface, it indicates a transfer is completed when this pin goes from low to high. An external pull-up resistor <b>MUST</b> hold this pin at HIGH level for the Motorola mode. An external pull-down resistor <b>MUST</b> hold this pin at LOW level for the Intel mode.
R11	40	$\overline{\text{CS}}$	<b>Chip Select (5 V-Tolerant Input)</b> Active low input used by the Motorola or Intel microprocessor to enable the microprocessor port access.
N11	39	$\overline{\text{R/W\_WR}}$	<b>Read/Write_Write (5 V-Tolerant Input)</b> This input controls the direction of the data bus lines (D0 - 15) during a microprocessor access. For the Motorola interface, this pin is set high and low for the read and write access respectively. For the Intel interface, a write access is indicated when this pin goes low.
R12	42	$\overline{\text{DS\_RD}}$	<b>Data Strobe_Read (5 V-Tolerant Input)</b> This active low input works in conjunction with $\overline{\text{CS}}$ to enable the microprocessor port read and write operations for the Motorola interface. A read access is indicated when it goes low for the Intel interface.

PBGA Pin Number	LQFP Pin Number	Pin Name	Description
K13, K15, K14, J11, J12, J13, J15, H11, J14, H12, H13, H15, G12, G13	82, 84, 86, 87, 88, 89, 90, 91, 92, 93, 94, 96, 98, 99	A0 - 13	<b>Address 0 to 13 (5 V-Tolerant Inputs)</b> These pins form the 14-bit address bus to the internal memories and registers.
M13	41	MOT_INTEL	<b>Motorola_Intel (5 V-Tolerant Input with Internal Pull-up)</b> This pin selects the Motorola or Intel microprocessor interface to be connected to the device. When this pin is unconnected or connected to high, Motorola interface is assumed. When this pin is connected to ground, Intel interface should be used.
G2	211	RESET	<b>Device Reset (5 V-Tolerant Input with Internal Pull-up)</b> This input (active LOW) puts the device in its reset state that disables the STio0 - 15 drivers. It also preloads registers with default values and clears all internal counters. To ensure proper reset action, the reset pin must be low for longer than 1 $\mu$ s. Upon releasing the reset signal to the device, the first microprocessor access cannot take place for at least 500 $\mu$ s due to the time required to stabilize the device from the power-down state. Refer to Section Section 11.2 on page 25 for details.

## 4.0 Device Overview

The device has sixteen ST-BUS/GCI-Bus inputs (STi0 - 15) and sixteen ST-BUS/GCI-Bus outputs (STio0 - 15). STio0 - 15 can also be configured as bi-directional pins, in which case STi0 - 15 will be ignored. It is a non-blocking digital switch with 1024 64 kbps channels. The ST-BUS/GCI-Bus inputs and outputs accept serial input data streams with data rates of 2.048 Mbps, 4.096 Mbps, 8.192 Mbps and 16.384 Mbps.

By using Zarlink's message mode capability, microprocessor data stored in the connection memory can be broadcast to the output streams on a per-channel basis. This feature is useful for transferring control and status information for external circuits or other ST-BUS/GCI-Bus devices.

The device uses the ST-BUS/GCI-Bus input frame pulse (FPI) and the ST-BUS/GCI-Bus input clock (CKi) to define the input frame boundary and timing for sampling the ST-BUS/GCI-Bus input streams with various data rates. The output data streams will be driven by and have their timing defined by FPI and CKi. A Motorola or Intel compatible non-multiplexed microprocessor port allows users to program the device to operate in various modes under different switching configurations. Users can use the microprocessor port to perform internal register and memory read and write operations. The microprocessor port has a 16-bit data bus, a 14-bit address bus and six control signals (MOT\_INTEL, CS, DS\_RD, R/W\_WR and DTA\_RDY).

The device supports the mandatory requirements of the IEEE-1149.1 (JTAG) standard via the test port.

## 5.0 Data Rates and Timing

The ZL50017 has 16 serial data inputs and 16 serial data outputs. All streams are programmed to operate at 2.048 Mbps, 4.096 Mbps, 8.192 Mbps or 16.384 Mbps. Depending on the data rate there will be 32 channels, 64 channels, 128 channels or 256 channels, respectively, during a 125  $\mu$ s frame.

The output streams can be programmed to operate as bi-directional streams. By setting BDL (bit 6) in the Internal Mode Selection (IMS) register, the input streams 0 - 15 (STI0 - 15) are internally tied low, and the output streams 0 - 15 (STIo0 - 15) are set to operate in a bi-directional mode. The input data rate is set on a per-stream basis by programming STIN[n]DR3 - 0 (bits 3 - 0) in the Stream Input Control Register 0 - 15 (SICR0 - 15). The output data rate is set on a per-stream basis by programming STO[n]DR3 - 0 (bits 3 - 0) in the Stream Output Control Register 0 - 15 (SOCR0 - 15). The output data rates do not have to match or follow the input data rates. The maximum number of channels switched is limited to 1024 channels. If all 16 input streams were operating at 8.192 Mbps (128 channels per stream), this would result in 2048 channels. Memory limitations prevent the device from operating at this capacity. A maximum capacity of 1024 channels will occur if four streams are operating at 16.384 Mbps, eight streams are operating at 8.192 Mbps or all sixteen streams are operating at 4.096 Mbps. With all streams operating at 2.048 Mbps, the capacity will be reduced to 512 channels. It should be noted that only full streams can be enabled, the device does not allow partial streams configuration (i.e., cannot have all the streams operating at 16.384 Mbps but only access the half the channels).

### 5.1 Input Clock (CKi) and Input Frame Pulse (FPi) Timing

The frequency of the input clock (CKi) for the ZL50017 must be at least twice the input/output data rate. For example, if the input/output data rate is 8.192 Mbps, the input clock, CKi, must be 16.384 MHz. Following the example above, if the input/output data rate is 4.096 Mbps, the input clock, CKi, must be 8.192 MHz. The only exception to this is for 16.384 Mbps input/output data. In this case, the input clock, CKi, is equal to the data rate. The input frame pulse, FPi, must always follow CKi. CKIN1 - 0 (bits 6 - 5) in the Control Register (CR) are used to program the width of the input frame pulse and the frequency of the input clock supplied to the device.

Highest <i>Input or Output</i> Data Rate	CKIN 1-0 Bits	Input Clock Rate (CKi)	Input Frame Pulse (FPi)
16.384 Mbps or 8.192 Mbps	00	16.384 MHz	8 kHz (61 ns wide pulse)
4.096 Mbps	01	8.192 MHz	8 kHz (122 ns wide pulse)
2.048 Mbps	10	4.096 MHz	8 kHz (244 ns wide pulse)

**Table 1 - CKi and FPi Configurations**

The ZL50017 accepts positive and negative ST-BUS/GCI-Bus input clock and input frame pulse formats via the programming of CKINP (bit 8) and FPINP (bit 7) in the Control Register (CR). By default, the device accepts the negative input clock format and ST-BUS format frame pulses. However, the switch can also accept a positive-going clock format by programming CKINP (bit 8) in the Control Register (CR). A GCI-Bus format frame pulse can be used by programming FPINPOS (bit 9) and FPINP (bit 7) in the Control Register (CR).

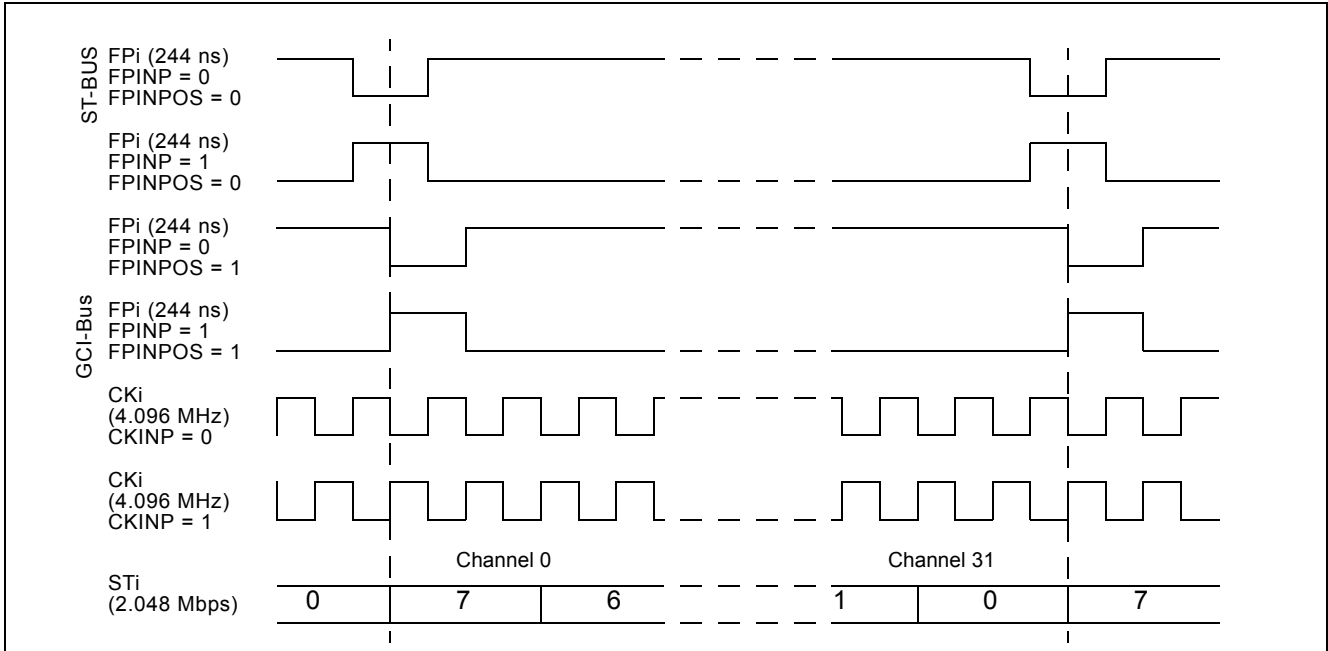

Figure 4 - Input Timing when CKIN1 - 0 bits = "10" in the CR

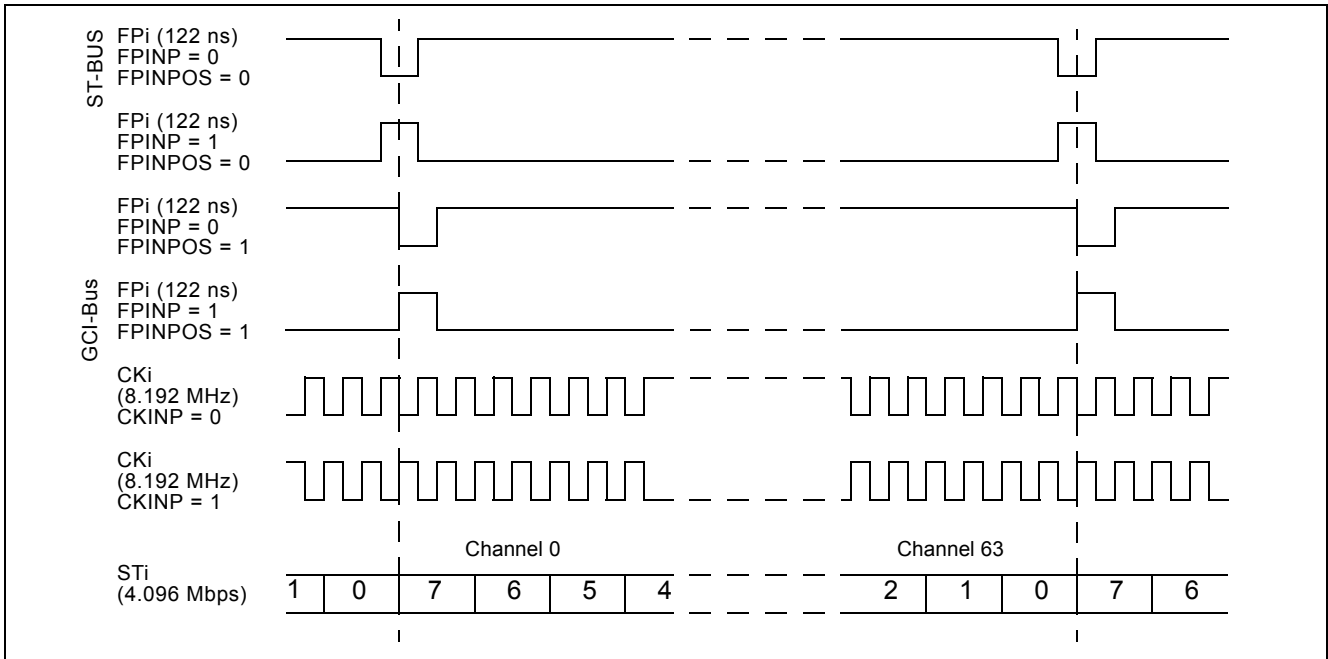

Figure 5 - Input Timing when CKIN1 - 0 bits = "01" in the CR

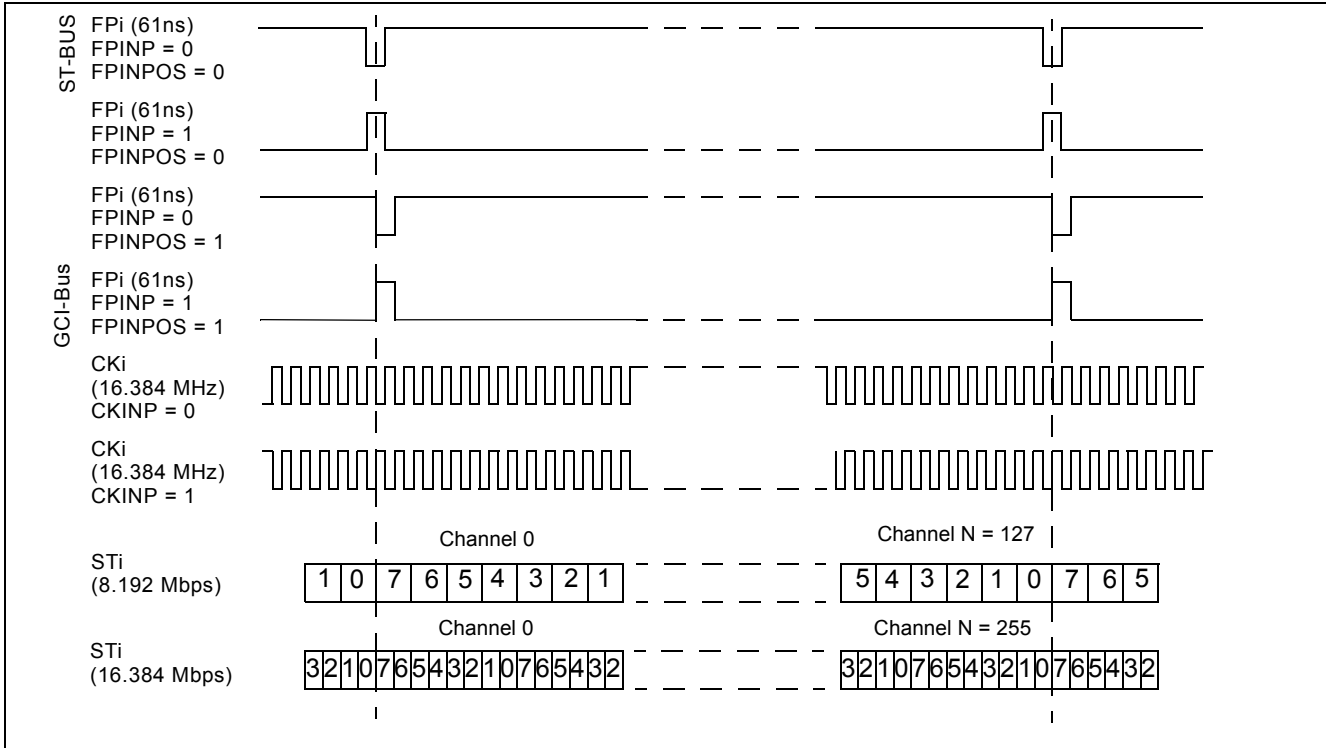

Figure 6 - Input Timing when CKIN1 - 0 = "00" in the CR

## 5.2 ST-BUS and GCI-Bus Timing

The ZL50017 is capable of operating using either the ST-BUS or GCI-Bus standards. By default, the ZL50017 is configured for ST-BUS input and output timing. To set the input timing to conform to the GCI-Bus standard, FPINPOS (bit 9) and FPINP (bit 7) in the Control Register (CR) must be set.

## 6.0 Data Input Delay and Data Output Advancement

Various registers are provided to adjust the input delay and output advancement for each input and output data stream. The input bit delay and output bit advancement can vary from 0 to 7 bits for each individual stream.

If input delay of less than a bit is desired, different sampling points can be used to handle the adjustments. The sampling point can vary from 1/4 to 4/4 with a 1/4-bit increment for all input streams. By default, the sampling point is set to the 3/4-bit location.

The fractional output bit advancement can vary from 0 to 3/4 bits, again with a 1/4 bit increment. By default, there is 0 output bit advancement.

Although input delay or output advancement features are available on streams which are operating in bi-directional mode it is not recommended, as it can easily cause bus contention. If users require this function, special attention must be given to the timing to ensure contention is minimized.

### 6.1 Input Bit Delay Programming

The input bit delay programming feature provides users with the flexibility of handling different wire delays when designing with source streams for different devices.

By default, all input streams have zero bit delay, such that bit 7 is the first bit that appears after the input frame boundary (assuming ST-BUS formatting). The input delay is enabled by STIN[n]BD2-0 (bits 8 - 6) in the Stream Input Control Register 0 - 15 (SICR0 - 15) as described in Table 10 on page 32. The input bit delay can range from 0 to 7 bits.

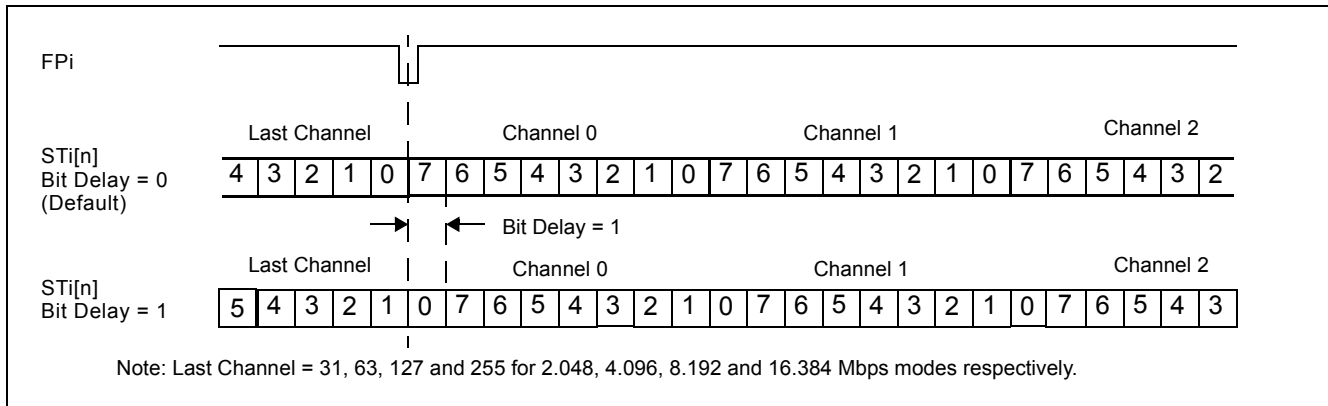

Figure 7 - Input Bit Delay Timing Diagram (ST-BUS)

### 6.2 Input Bit Sampling Point Programming

In addition to the input bit delay feature, the ZL50017 allows users to change the sampling point of the input bit by programming STIN[n]SMP 1-0 (bits 5 - 4) in the Stream Input Control Register 0 - 15 (SICR0 - 15). For input streams the default sampling point is at 3/4 bit and users can change the sampling point to 1/4, 1/2, 3/4 or 4/4 bit position.

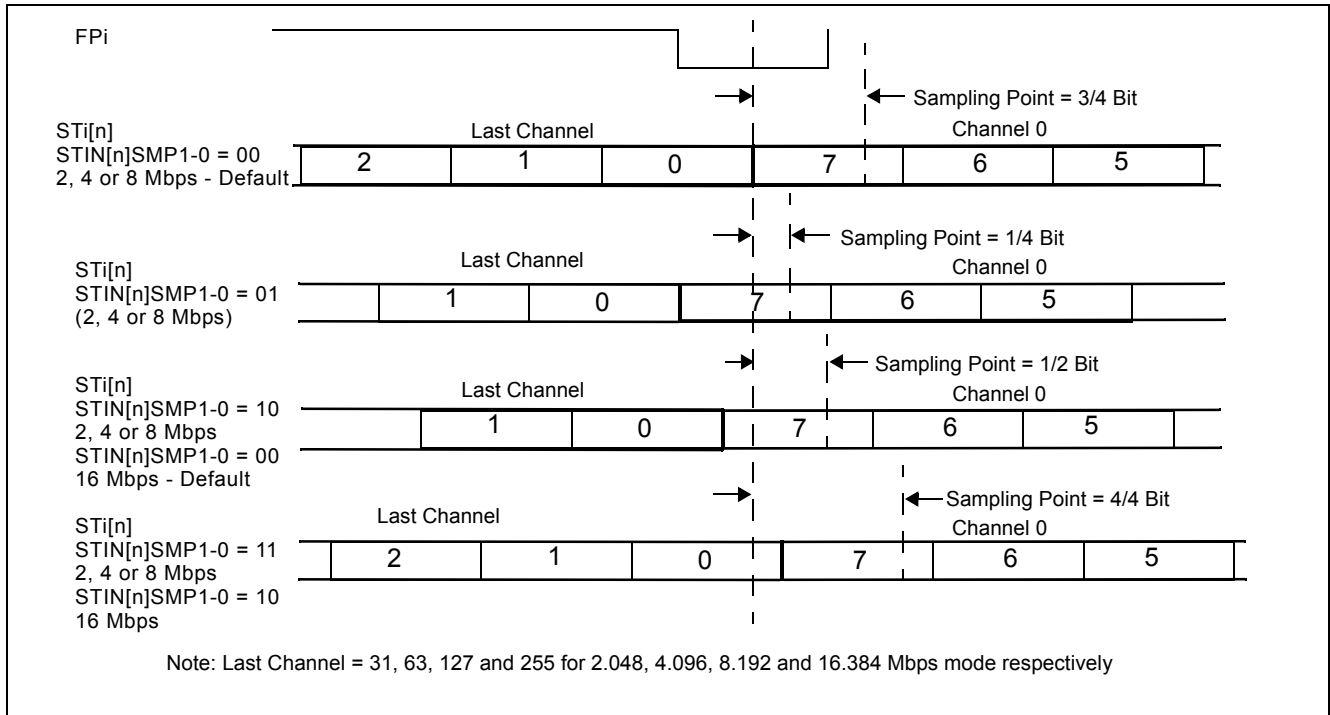
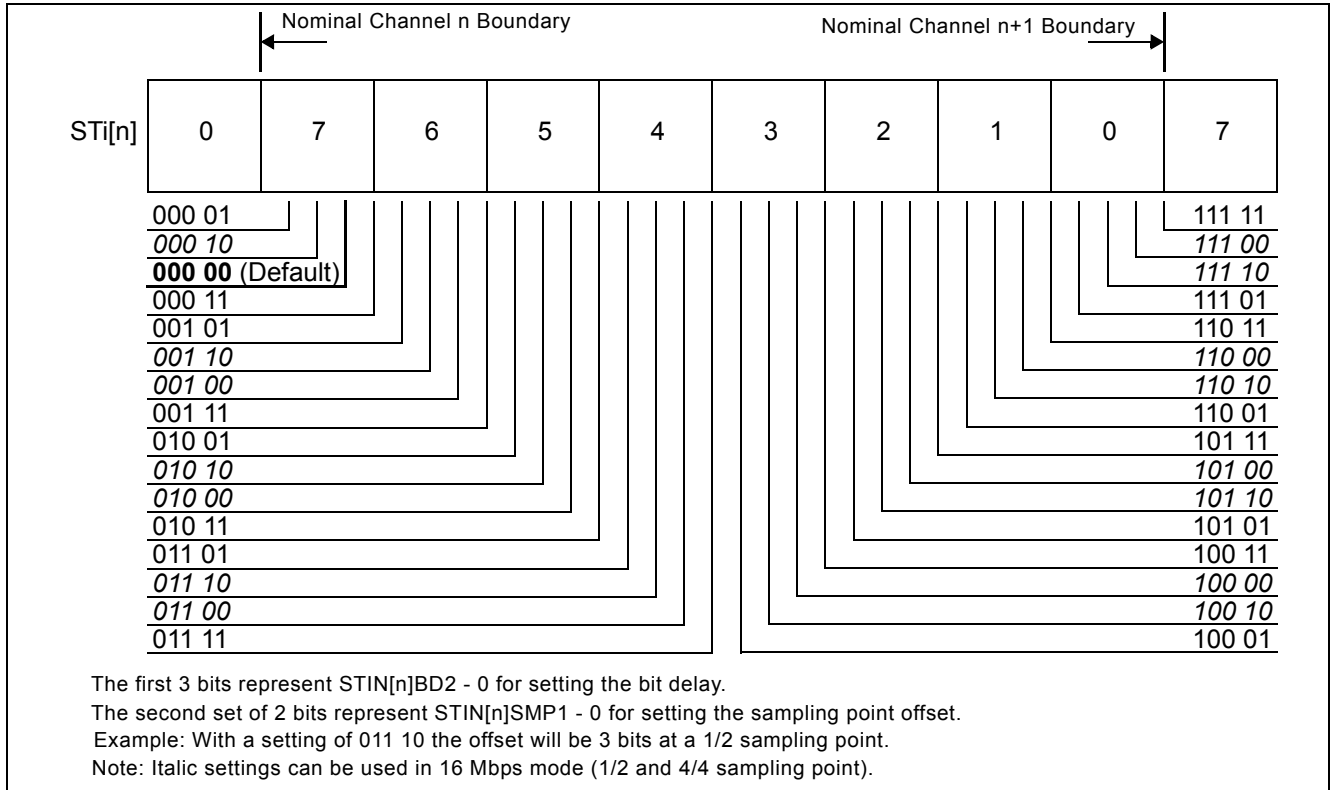

Figure 8 - Input Bit Sampling Point Programming

The input delay is controlled by STIN[n]BD2-0 (bits 8 - 6) to control the bit shift and STIN[n]SMP1 - 0 (bits 5 - 4) to control the sampling point in the Stream Input Control Register 0 - 15 (SICR0 - 15).



**Figure 9 - Input Bit Delay and Fractional Sampling Point**

### 6.3 Output Advancement Programming

This feature is used to advance the output data of individual output streams with respect to the input frame boundary. Each output stream has its own bit advancement value which can be programmed in the Stream Output Control Register 0 - 15 (SOCR0 - 15).

By default, all output streams have zero bit advancement such that bit 7 is the first bit that appears after the input frame boundary (assuming ST-BUS formatting). The output advancement is enabled by STO[n]AD 2 - 0 (bits 6 - 4) of the Stream Output Control Register 0 - 15 (SOCR0 - 15) as described in Table 11 on page 33. The output bit advancement can vary from 0 to 7 bits.

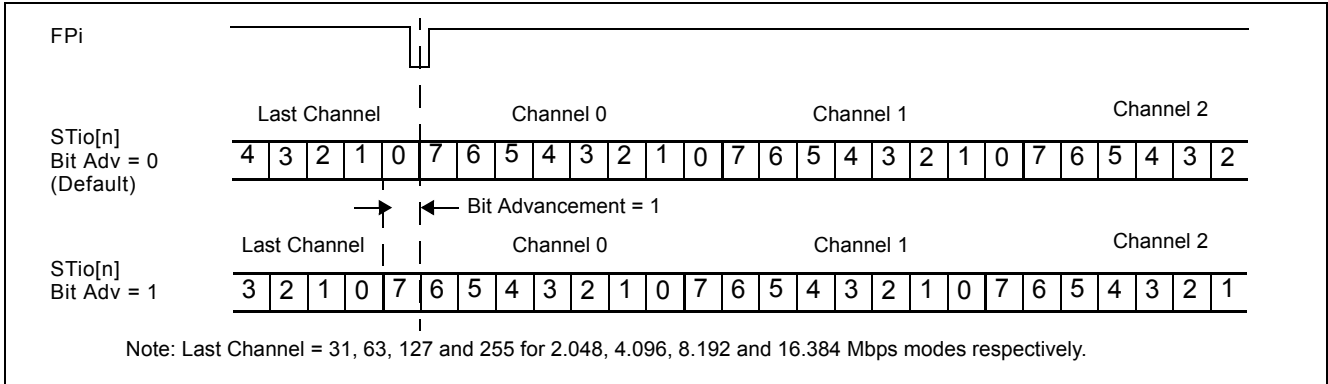

Figure 10 - Output Bit Advancement Timing Diagram (ST-BUS)

### 6.4 Fractional Output Bit Advancement Programming

In addition to the output bit advancement, the device has a fractional output bit advancement feature that offers better resolution. The fractional output bit advancement is useful in compensating for varying parasitic load on the serial data output pins.

By default all of the streams have zero fractional bit advancement such that bit 7 is the first bit that appears after the output frame boundary. The fractional output bit advancement is enabled by STO[n]FA 1 - 0 (bits 8 - 7) in the Stream Output Control Register 0 - 15 (SOCR0 - 15). For all streams the fractional bit advancement can vary from 0, 1/4, 1/2 to 3/4 bits.

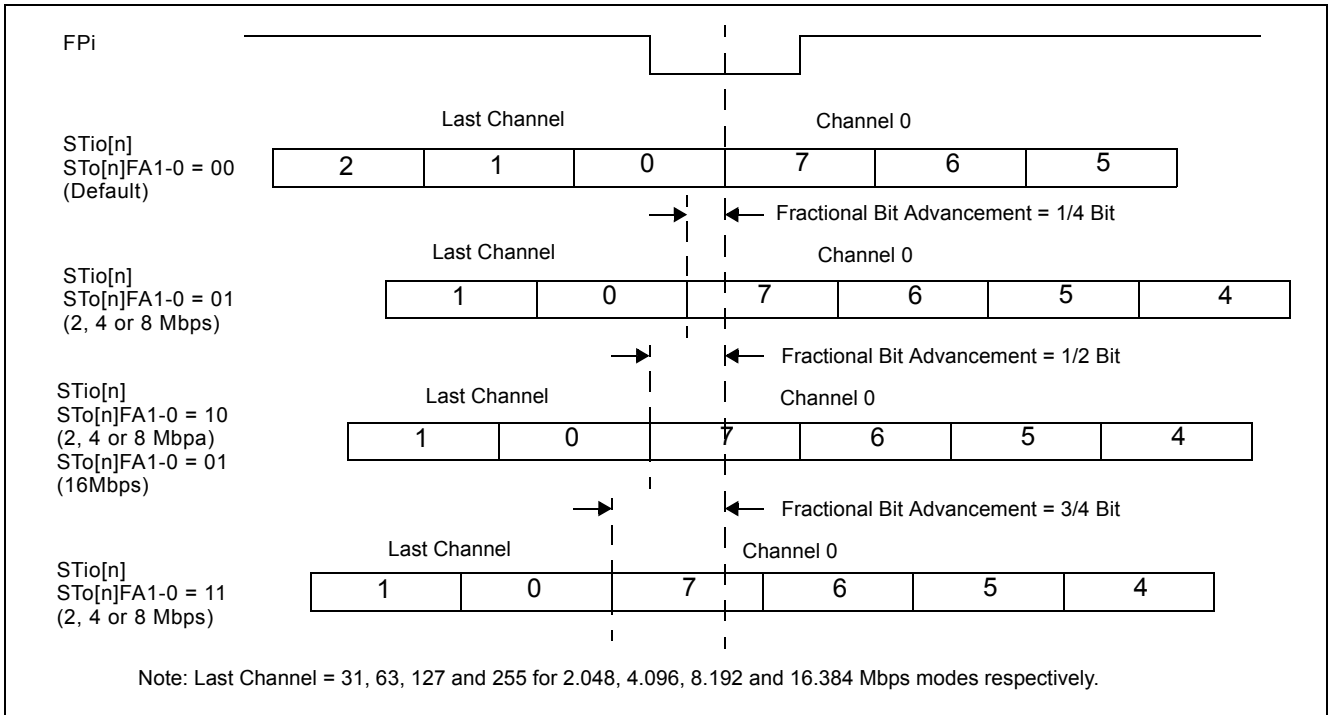

Figure 11 - Output Fractional Bit Advancement Timing Diagram (ST-BUS)

## 7.0 Data Delay Through the Switching Paths

The switching of information from the input serial streams to the output serial streams results in a throughput delay. The device can be programmed to perform timeslot interchange functions with different throughput delay capabilities on a per-channel basis. For voice applications, select variable throughput delay to ensure minimum delay between input and output data. In wideband data applications, select constant delay to maintain the frame integrity of the information through the switch. The delay through the device varies according to the type of throughput delay selected by the  $V/\overline{C}$  (bit 14) in the Connection Memory Low when CMM = 0.

### 7.1 Variable Delay Mode

Variable delay mode causes the output channel to be transmitted as soon as possible. This is a useful mode for voice applications where the minimum throughput delay is more important than frame integrity. The delay through the switch can vary from 7 channels to 1 frame + 7 channels. To set the device into variable delay mode, VAREN (bit 4) in the Control Register (CR) must be set before  $V/\overline{C}$  (bit 14) in the Connection Memory Low when CMM = 0. If the VAREN bit is not set and the device is programmed for variable delay mode, the information read on the output stream will not be valid.

In variable delay mode, the delay depends on the combination of the source and destination channels of the input and output streams.

m = input channel number n = output channel number	n-m ≤ 0	0 < n-m < 7	n-m = 7		n-m > 7
			STio < STi	STio ≥ STi	
T = Delay between input and output	1 frame - (m-n)	1 frame + (n-m)	n-m		

Table 2 - Delay for Variable Delay Mode

For example, if Stream 4 Channel 2 is switched to Stream 5 Channel 9 with variable delay, the data will be output in the same 125 μs frame. Contrarily, if Stream 6 Channel 1 is switched to Stream 9 Channel 3, the information will appear in the following frame.

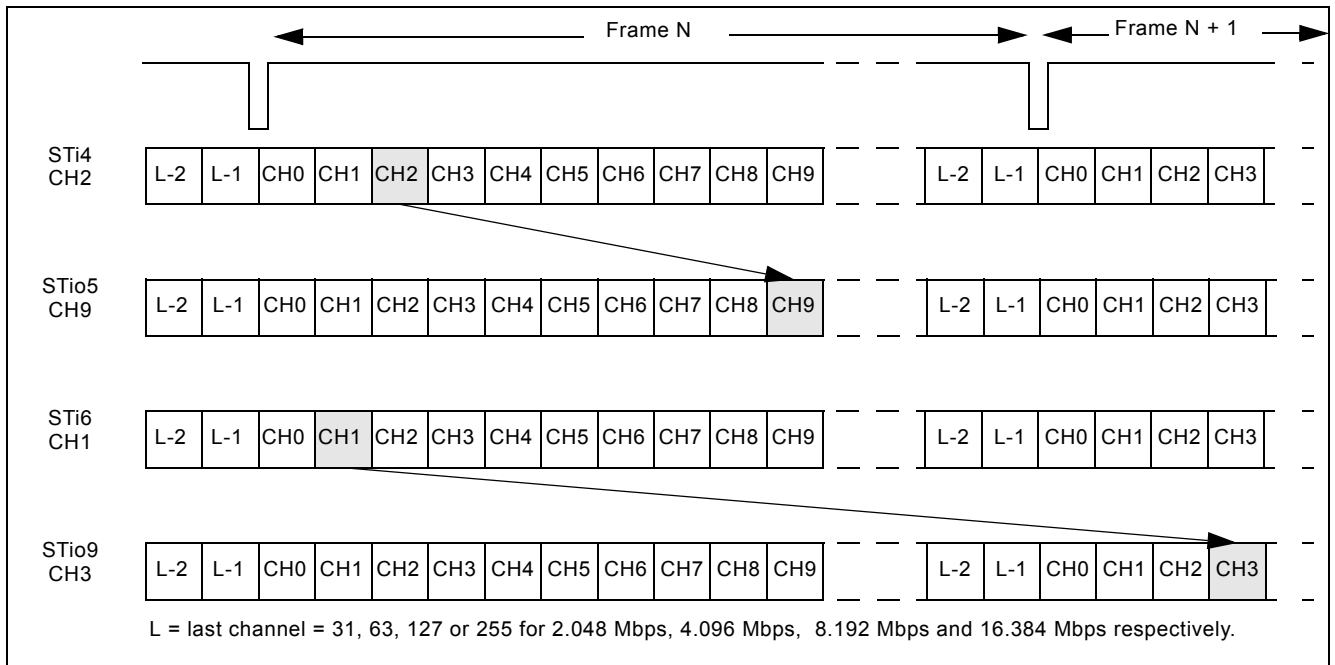

Figure 12 - Data Throughput Delay for Variable Delay

### 7.2 Constant Delay Mode

In this mode, frame integrity is maintained in all switching configurations. The delay through the switch is 2 frames - Input Channel + Output Channel. This can result in a minimum of 1 frame + 1 channel delay if the last channel on a stream is switched to the first channel of a stream. The maximum delay is 3 frames - 1 channel. This occurs when the first channel of a stream is switched to the last channel of a stream. The constant delay mode is available for all output channels.

The data throughput delay is expressed as a function of ST-BUS/GCI-Bus frames, input channel number (m) and output channel number (n). The data throughput delay (T) is:

$$T = 2 \text{ frames} + (n - m)$$

The constant delay mode is controlled by  $\overline{V/C}$  (bit 14) in the Connection Memory Low when CMM = 0. When this bit is set low, the channel is in constant delay mode. If VAREN (bit 4) in the Control Register (CR) is set (to enable variable throughput delay on a chip-wide basis), the device can still be programmed to operate in constant delay mode.

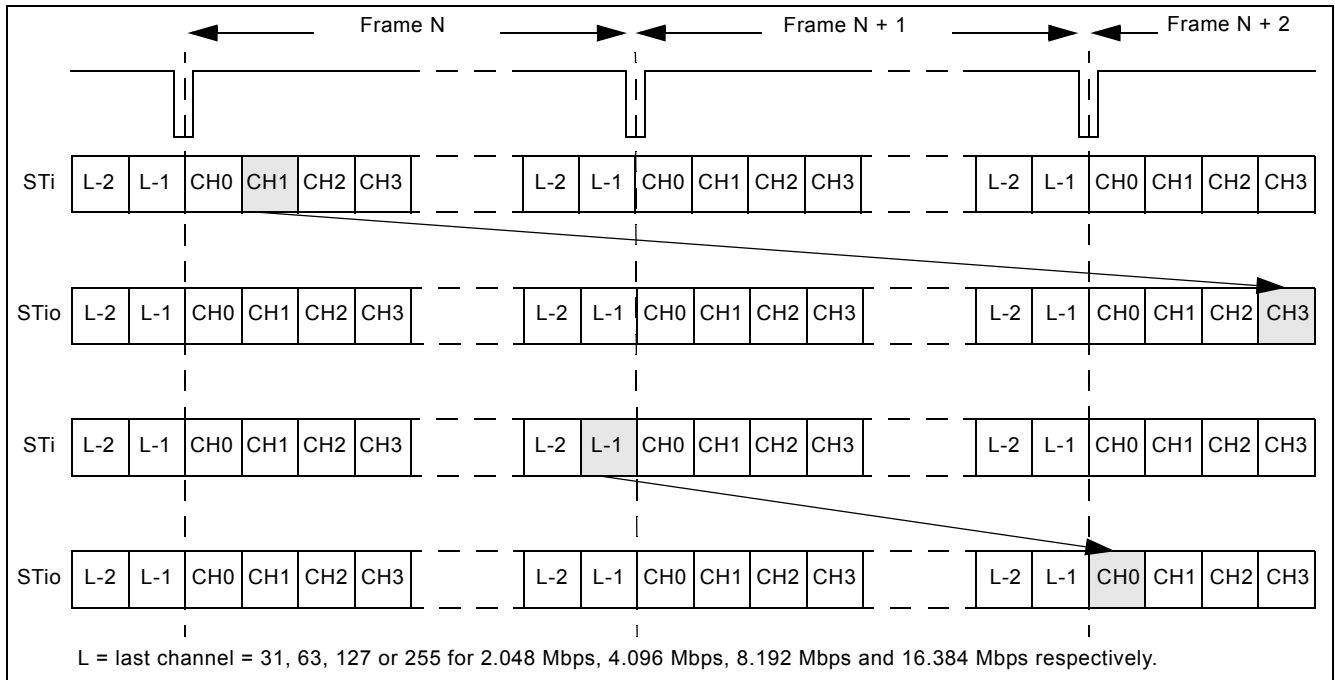

Figure 13 - Data Throughput Delay for Constant Delay

### 8.0 Connection Memory Description

The connection memory consists of two blocks, Connection Memory Low (CM\_L). The CM\_L is 16 bits wide and is used for channel switching and other special modes. Each connection memory location of the CM\_L or CM\_H can be read or written via the 16 bit microprocessor port within one microprocessor access cycle. See Table 12 on page 34 for the address mapping of the connection memory. Any unused bits will be reset to zero on the 16-bit data bus.

For the normal channel switching operation, CMM (bit 0) of the Connection Memory Low (CM\_L) is programmed low. SCA7 - 0 (bits 8 - 1) indicate the source (input) channel address and SSA4 - 0 (bits 13 - 9) indicate the source (input) stream address. When CMM (bit 0) of the Connection Memory Low (CM\_L) is programmed high, the ZL50017 will operate in one of the special modes described in Table 14 on page 36. When the per-channel message mode is enabled, MSG7 - 0 (bit 10 - 3) in the Connection Memory Low (CM\_L) will be output via the serial data stream as message output data.

## 9.0 Connection Memory Block Programming

This feature allows for fast initialization of the connection memory after power up.

### 9.1 Memory Block Programming Procedure

1. Set MBPE (bit 3) in the Control Register (CR) from low to high.
2. Configure BPD2 - 0 (bits 3 - 1) in the Internal Mode Selection (IMS) register to the desired values to be loaded into CM\_L.
3. Start the block programming by setting MBPS (bit 0) in the Internal Mode Selection Register (IMS) high. The values stored in BPD2 - 0 will be loaded into bits 2 - 0 of all CM\_L positions. The remaining CM\_L locations (bits 15 - 3).

The following tables show the resulting values that are in the CM\_L and CM\_H connection memory locations.

Bit	15	14	13	12	11	10	9	8	7	6	5	4	3	2	1	0
Value	0	0	0	0	0	0	0	0	0	0	0	0	0	BPD2	BPD1	BPD0

**Table 3 - Connection Memory Low After Block Programming**

It takes at least two frame periods (250  $\mu$ s) to complete a block program cycle.

MBPS (bit 0) in the Control Register (CR) will automatically reset to a low position after the block programming process has completed.

MBPE (bit 3) in the Internal Mode Selection (IMS) register must be cleared from high to low to terminate the block programming process. This is not an automatic action taken by the device and must be performed manually.

**Note:** Once the block program has been initiated, it can be terminated at any time prior to completion by setting MBPS (bit 0) in the Control Register (CR) or MBPE (bit 3) in the Internal Mode Selection (IMS) register to low.

## 10.0 Microprocessor Port

The device provides access to the internal registers, connection memories and data memories via the microprocessor port. The microprocessor port is capable of supporting both Motorola and Intel non-multiplexed microprocessors. The microprocessor port consists of a 16-bit parallel data bus (D15 - 0), 14 bit address bus (A13 - 0) and six control signals (MOT\_INTEL, CS, DS\_RD, R/W\_WR and DTA\_RDY).

The data memory can only be read from the microprocessor port. For a data memory read operation, D7 - 0 will be used and D15 - 8 will output zeros.

For a CM\_L read or write operation, all bits (D15 - 0) of the data bus will be used. For a CM\_H write operation, D4 - 0 of the data bus must be configured and D15 - 5 are ignored. D15 - 5 must be driven either high or low. For a CM\_H read operation, D4 - 0 will be used and D15 - 5 will output zeros.

Refer to Figure 15 on page 39, Figure 16 on page 40, Figure 17 on page 41 and Figure 18 on page 42 for the microprocessor timing.

## 11.0 Device Reset and Initialization

The  $\overline{\text{RESET}}$  pin is used to reset the ZL50017. When this pin is low, the following functions are performed:

- synchronously puts the microprocessor port in a reset state
- tristates the STio0 - 15 outputs
- preloads all internal registers with their default values (refer to the individual registers for default values)
- clears all internal counters

### 11.1 Power-up Sequence

The recommended power-up sequence is for the  $V_{\text{DD\_IO}}$  supply (normally +3.3 V) to be established before the power-up of the  $V_{\text{DD\_CORE}}$  supply (normally +1.8 V). The  $V_{\text{DD\_CORE}}$  supply may be powered up at the same time as  $V_{\text{DD\_IO}}$ , but should not “lead” the  $V_{\text{DD\_IO}}$  supply by more than 0.3 V.

### 11.2 Device Initialization on Reset

Upon power up, the ZL50017 should be initialized as follows:

- Set the ODE pin to low to disable the STio0 - 15 outputs
- Set the  $\overline{\text{TRST}}$  pin to low to disable the JTAG TAP controller
- Reset the device by pulsing the  $\overline{\text{RESET}}$  pin to zero for longer than 1  $\mu\text{s}$
- After releasing the  $\overline{\text{RESET}}$  pin from low to high, wait for a certain period of time (see Note below) for the device to stabilize from the power down state before the first microprocessor port access can occur
- Wait at least 500  $\mu\text{s}$  prior to the next microport access (see Note below)
- Use the block programming mode to initialize the connection memory
- Release the ODE pin from low to high after the connection memory is programmed

**Note:** If CKi is 16.384 MHz, the waiting time is 500  $\mu\text{s}$ ; if CKi is 8.192 MHz, the waiting time is 1 ms; if CKi is 4.096 MHz, the waiting time is 2 ms.

### 11.3 Software Reset

In addition to the hardware reset from the  $\overline{\text{RESET}}$  pin, the device can also be reset by using software reset SRSTSW (bit 1) in the Software Reset Register (SRR).

## 12.0 JTAG Port

The JTAG test port is implemented to meet the mandatory requirements of the IEEE-1149.1 (JTAG) standard. The operation of the boundary-scan circuitry is controlled by an external Test Access Port (TAP) Controller.

### 12.1 Test Access Port (TAP)

The Test Access Port (TAP) accesses the ZL50017 test functions. It consists of three input pins and one output pin as follows:

- **Test Clock Input (TCK)** - TCK provides the clock for the test logic. TCK does not interfere with any on-chip clock and thus remains independent in the functional mode. TCK permits shifting of test data into or out of the Boundary-Scan register cells concurrently with the operation of the device and without interfering with the on-chip logic.

- **Test Mode Selection Inputs (TMS)** - The TAP Controller uses the logic signals received at the TMS input to control test operations. The TMS signals are sampled at the rising edge of the TCK pulse. This pin is internally pulled to high when it is not driven from an external source.
- **Test Data Input (TDi)** - Serial input data applied to this port is fed either into the instruction register or into a test data register, depending on the sequence previously applied to the TMS input. The registers are described in a subsequent section. The received input data is sampled at the rising edge of the TCK pulse. This pin is internally pulled to high when it is not driven from an external source.
- **Test Data Output (TDo)** - Depending on the sequence previously applied to the TMS input, the contents of either the instruction register or test data register are serially shifted out towards TDo. The data from TDo is clocked on the falling edge of the TCK pulses. When no data is shifted through the boundary scan cells, the TDo driver is set to a high impedance state.
- **Test Reset (TRST)** - Resets the JTAG scan structure. This pin is internally pulled to high when it is not driven from an external source.

## 12.2 Instruction Register

The ZL50017 uses the public instructions defined in the IEEE-1149.1 standard. The JTAG interface contains a four-bit instruction register. Instructions are serially loaded into the instruction register from the TDi when the TAP Controller is in its shifted-OR state. These instructions are subsequently decoded to achieve two basic functions: to select the test data register that may operate while the instruction is current and to define the serial test data register path that is used to shift data between TDi and TDo during data register scanning.

## 12.3 Test Data Registers

As specified in the IEEE-1149.1 standard, the ZL50017 JTAG interface contains three test data registers:

- **The Boundary-Scan Register** - The Boundary-Scan register consists of a series of boundary-scan cells arranged to form a scan path around the boundary of the ZL50017 core logic.
- **The Bypass Register** - The Bypass register is a single stage shift register that provides a one-bit path from TDi to TDo.
- **The Device Identification Register** - The JTAG device ID for the ZL50017 is 0C36114B<sub>H</sub>

Version	<31:28>	0000
Part Number	<27:12>	1100 0011 0110 0001
Manufacturer ID	<11:1>	0001 0100 101
LSB	<0>	1

## 12.4 BSDL

A Boundary Scan Description Language (BSDL) file is available from Zarlink Semiconductor to aid in the use of the IEEE-1149.1 test interface.

### 13.0 Register Address Mapping

Address A13 - A0	CPU Access	Register Name	Abbreviation	Reset By
0000 <sub>H</sub>	R/W	Control Register	CR	Switch/Hardware
0001 <sub>H</sub>	R/W	Internal Mode Selection Register	IMS	Switch/Hardware
0002 <sub>H</sub>	R/W	Software Reset Register	SRR	Hardware Only
0008 <sub>H</sub>	R/W	Data Rate Selection Register	DRSR	Switch/Hardware
0010 <sub>H</sub>	R Only	Internal Flag Register	IFR	Switch/Hardware
0100 <sub>H</sub> - 010F <sub>H</sub>	R/W	Stream Input Control Registers 0 - 15	SICR0 - 15	Switch/Hardware
0200 <sub>H</sub> - 020F <sub>H</sub>	R/W	Stream Output Control Registers 0 - 15	SOCR0 - 15	Switch/Hardware

**Table 4 - Address Map for Registers (A13 = 0)**

## 14.0 Detailed Register Description

External Read/Write Address: 0000 <sub>H</sub> Reset Value: 0000 <sub>H</sub>																														
15	14	13	12	11	10	9	8	7	6	5	4	3	2	1	0															
0	0	0	0	0	0	FPIN POS	CKINP	FPINP	CKIN 1	CKIN 0	VAR EN	MBPE	OSB	MS1	MS0															
Bit	Name	Description																												
15 - 10	Unused	<b>Reserved.</b> In normal functional mode, these bits <b>MUST</b> be set to zero.																												
9	FPINPOS	<b>Input Frame Pulse (FPI) Position</b> When this bit is low, FPI straddles frame boundary (as defined by ST-BUS). When this bit is high, FPI starts from frame boundary (as defined by GCI-Bus)																												
8	CKINP	<b>Clock Input (CKi) Polarity</b> When this bit is low, the CKi falling edge aligns with the frame boundary. When this bit is high, the CKi rising edge aligns with the frame boundary.																												
7	FPINP	<b>Frame Pulse Input (FPI) Polarity</b> When this bit is low, the input frame pulse FPI has the negative frame pulse format. When this bit is high, the input frame pulse FPI has the positive frame pulse format.																												
6 - 5	CKIN1 - 0	<b>Input Clock (CKi) and Frame Pulse (FPI) Selection</b>																												
		<table border="1"> <thead> <tr> <th>CKIN1 - 0</th><th>FPI Active Period</th><th>CKi</th></tr> </thead> <tbody> <tr> <td>00</td><td>61 ns</td><td>16.384 MHz</td></tr> <tr> <td>01</td><td>122 ns</td><td>8.192 MHz</td></tr> <tr> <td>10</td><td>244 ns</td><td>4.096 MHz</td></tr> <tr> <td>11</td><td colspan="2">Reserved</td></tr> </tbody> </table>			CKIN1 - 0	FPI Active Period	CKi	00	61 ns	16.384 MHz	01	122 ns	8.192 MHz	10	244 ns	4.096 MHz	11	Reserved												
CKIN1 - 0	FPI Active Period	CKi																												
00	61 ns	16.384 MHz																												
01	122 ns	8.192 MHz																												
10	244 ns	4.096 MHz																												
11	Reserved																													
		The MODE_4M0 and MODE_4M1 pins, as described in “Pin Description” on page 9, should also be set to define the input clock mode.																												
4	VAREN	<b>Variable Delay Mode Enable</b> When this bit is low, the variable delay mode is disabled on a device-wide basis. When this bit is high, the variable delay mode is enabled on a device-wide basis.																												
3	MBPE	<b>Memory Block Programming Enable</b> When this bit is high, the connection memory block programming mode is enabled to program the connection memory. When it is low, the memory block programming mode is disabled.																												

**Table 5 - Control Register (CR) Bits**

External Read/Write Address: 0000 <sub>H</sub> Reset Value: 0000 <sub>H</sub>															
15	14	13	12	11	10	9	8	7	6	5	4	3	2	1	0
0	0	0	0	0	0	FPIN POS	CKINP	FPINP	CKIN 1	CKIN 0	VAR EN	MBPE	OSB	MS1	MS0

Bit	Name	Description																														
2	OSB	<p><b>Output Stand By Bit:</b>                      This bit enables the STio0 - 1 serial outputs. The following table describes the HiZ control of the serial data outputs:</p> <table border="1" style="margin-left: auto; margin-right: auto; border-collapse: collapse;"> <thead> <tr> <th style="text-align: center;">RESET Pin</th> <th style="text-align: center;">SRSTSW (in SRR)</th> <th style="text-align: center;">ODE Pin</th> <th style="text-align: center;">OSB Bit</th> <th style="text-align: center;">STio0 - 15</th> </tr> </thead> <tbody> <tr> <td style="text-align: center;">0</td> <td style="text-align: center;">X</td> <td style="text-align: center;">X</td> <td style="text-align: center;">X</td> <td style="text-align: center;">HiZ</td> </tr> <tr> <td style="text-align: center;">1</td> <td style="text-align: center;">1</td> <td style="text-align: center;">X</td> <td style="text-align: center;">X</td> <td style="text-align: center;">HiZ</td> </tr> <tr> <td style="text-align: center;">1</td> <td style="text-align: center;">0</td> <td style="text-align: center;">0</td> <td style="text-align: center;">X</td> <td style="text-align: center;">HiZ</td> </tr> <tr> <td style="text-align: center;">1</td> <td style="text-align: center;">0</td> <td style="text-align: center;">1</td> <td style="text-align: center;">0</td> <td style="text-align: center;">HiZ</td> </tr> <tr> <td style="text-align: center;">1</td> <td style="text-align: center;">0</td> <td style="text-align: center;">1</td> <td style="text-align: center;">1</td> <td style="text-align: center;">Active (Controlled by CM)</td> </tr> </tbody> </table> <p>Note: Unused output streams are tristated (STio = HiZ). Refer to SOCR0 - 15 (bit 2 - 0).</p>	RESET Pin	SRSTSW (in SRR)	ODE Pin	OSB Bit	STio0 - 15	0	X	X	X	HiZ	1	1	X	X	HiZ	1	0	0	X	HiZ	1	0	1	0	HiZ	1	0	1	1	Active (Controlled by CM)
RESET Pin	SRSTSW (in SRR)	ODE Pin	OSB Bit	STio0 - 15																												
0	X	X	X	HiZ																												
1	1	X	X	HiZ																												
1	0	0	X	HiZ																												
1	0	1	0	HiZ																												
1	0	1	1	Active (Controlled by CM)																												
1 - 0	MS1 - 0	<p><b>Memory Select Bits</b>                      These two bits are used to select connection memory low, connection high or data memory for access by CPU:</p> <table border="1" style="margin-left: auto; margin-right: auto; border-collapse: collapse;"> <thead> <tr> <th style="text-align: center;">MS1 - 0</th> <th style="text-align: center;">Memory Selection</th> </tr> </thead> <tbody> <tr> <td style="text-align: center;">00</td> <td style="text-align: center;">Connection Memory Low Read/Write</td> </tr> <tr> <td style="text-align: center;">01</td> <td style="text-align: center;">Reserved</td> </tr> <tr> <td style="text-align: center;">10</td> <td style="text-align: center;">Data Memory Read</td> </tr> <tr> <td style="text-align: center;">11</td> <td style="text-align: center;">Reserved</td> </tr> </tbody> </table>	MS1 - 0	Memory Selection	00	Connection Memory Low Read/Write	01	Reserved	10	Data Memory Read	11	Reserved																				
MS1 - 0	Memory Selection																															
00	Connection Memory Low Read/Write																															
01	Reserved																															
10	Data Memory Read																															
11	Reserved																															

**Table 5 - Control Register (CR) Bits (continued)**

External Read/Write Address: 0001 <sub>H</sub> Reset Value: 0000 <sub>H</sub>															
15	14	13	12	11	10	9	8	7	6	5	4	3	2	1	0
0	0	0	0	0	0	0	STIO_PD_EN	0	BD	0	0	BPD 2	BPD 1	BPD 0	MBPS
Bit	Name	Description													
15 - 9	Unused	<b>Reserved.</b> In normal functional mode, these bits <b>MUST</b> be set to zero.													
8	STIO_PD_EN	<b>STio Pull-down Enable</b> When this bit is low, the pull-down resistors on all STio pads will be disabled. When this bit is high, the pull-down resistors on all STio pads will be enabled.													
7	Unused	<b>Reserved.</b> In normal functional mode, these bits <b>MUST</b> be set to zero.													
6	BD	<b>Bi-directional Control</b> <table border="1" data-bbox="676 845 1139 1079"> <thead> <tr> <th>BDL</th><th>STio0 - 15 Operation</th></tr> </thead> <tbody> <tr> <td>0</td><td>normal operation: STi0-15 are inputs STio0-15 are outputs</td></tr> <tr> <td>1</td><td>bi-directional operation: STi0-15 tied low internally STio0-15 are bi-directional</td></tr> </tbody> </table>	BDL	STio0 - 15 Operation	0	normal operation: STi0-15 are inputs STio0-15 are outputs	1	bi-directional operation: STi0-15 tied low internally STio0-15 are bi-directional							
BDL	STio0 - 15 Operation														
0	normal operation: STi0-15 are inputs STio0-15 are outputs														
1	bi-directional operation: STi0-15 tied low internally STio0-15 are bi-directional														
5 - 4	Unused	<b>Reserved.</b> In normal functional mode, these bits <b>MUST</b> be set to zero.													
3 - 1	BPD2 - 0	<b>Block Programming Data</b> These bits refer to the value to be loaded into the connection memory, whenever the memory block programming feature is activated. After the MBPE bit in the Control Register is set to high and the MBPS bit in this register is set to high, the contents of the bits BPD2 - 0 are loaded into bits 2 - 0 of the Connection Memory Low. Bits 15 - 3 of the Connection Memory Low.													
0	MBPS	<b>Memory Block Programming Start:</b> A zero to one transition of this bit starts the memory block programming function. The MBPS and BPD2 - 0 bits in this register must be defined in the same write operation. Once the MBPE bit in the Control Register is set to high, the device requires two frames to complete the block programming. After the programming function has finished, the MBPS bit returns to low, indicating the operation is completed. When MBPS is high, MBPS or MBPE can be set to low to abort the programming operation. Whenever the microprocessor writes a one to the MBPS bit, the block programming function is started. As long as this bit is high, the user must maintain the same logical value to the other bits in this register to avoid any change in the device setting.													

**Table 6 - Internal Mode Selection Register (IMS) Bits**

External Read/Write Address: 0002 <sub>H</sub> Reset Value: 0000 <sub>H</sub>															
15	14	13	12	11	10	9	8	7	6	5	4	3	2	1	0
0	0	0	0	0	0	0	0	0	0	0	0	0	0	SRST SW	0
Bit	Name	Description													
15 - 2	Unused	<b>Reserved</b> In normal functional mode, these bits <b>MUST</b> be set to zero.													
1	SRSTSW	<b>Software Reset Bit for Switch</b> When this bit is low, switching blocks are in normal operation. When this bit is high, switching blocks are in software reset state. Refer to Table 12, "Address Map for Registers (A13 = 0)" on page 32 for details regarding which registers are affected.													
0	Unused	<b>Reserved</b> In normal functional mode, these bits <b>MUST</b> be set to zero.													

**Table 7 - Software Reset Register (SRR) Bits**

External Read/Write Address: 0008 <sub>H</sub> Reset Value: 0000 <sub>H</sub>																															
15	14	13	12	11	10	9	8	7	6	5	4	3	2	1	0																
0	0	0	0	0	0	0	0	0	0	0	0	DR3	DR2	DR1	DR0																
Bit	Name	Description																													
15 - 4	Unused	<b>Reserved</b> In normal functional mode, these bits <b>MUST</b> be set to zero.																													
3 - 0	DR3 - 0	<b>Input/Output Data Rate Selection Bits:</b> These bits set the data rate for both input and output streams																													
		<table border="1"> <thead> <tr> <th>DR3 - 0</th><th>STio0 - 15 Operation</th></tr> </thead> <tbody> <tr> <td>0000</td><td>Reserved</td></tr> <tr> <td>0001</td><td>2.048 Mbps</td></tr> <tr> <td>0010</td><td>4.096 Mbps</td></tr> <tr> <td>0011</td><td>8.192 Mbps</td></tr> <tr> <td>0100</td><td>16.384 Mbps</td></tr> <tr> <td>0101 - 1111</td><td>Reserved</td></tr> </tbody> </table>		DR3 - 0	STio0 - 15 Operation	0000	Reserved	0001	2.048 Mbps	0010	4.096 Mbps	0011	8.192 Mbps	0100	16.384 Mbps	0101 - 1111	Reserved														
DR3 - 0	STio0 - 15 Operation																														
0000	Reserved																														
0001	2.048 Mbps																														
0010	4.096 Mbps																														
0011	8.192 Mbps																														
0100	16.384 Mbps																														
0101 - 1111	Reserved																														

**Table 8 - Data Rate Selection Register**

External Read Address: 0010 <sub>H</sub> Reset Value: 0000 <sub>H</sub>																
15	14	13	12	11	10	9	8	7	6	5	4	3	2	1	0	
0	0	0	0	0	0	0	0	0	0	0	0	0	0	0	0	PERR
Bit	Name	Description														
15 - 1	Unused	<b>Reserved</b> In normal functional mode, these bits are zero.														
0	PERR	<b>Program Error (Read Only)</b> This bit is set high when the total number of input/output channels is programmed to be more than the maximum capacity of 1024, in which case the input/output channels beyond the maximum capacity should be disabled. This bit will be cleared automatically after the total number of active streams/channels is correctly programmed to be 1024 channels or below.														

Table 9 - Internal Flag Register (IFR) Bits - Read Only

External Read/Write Address: 0100 <sub>H</sub> - 010F <sub>H</sub> Reset Value: 0000 <sub>H</sub>																
15	14	13	12	11	10	9	8	7	6	5	4	3	2	1	0	
0	0	0	0	0	0	0	0	STIN[n] BD2	STIN[n] BD1	STIN[n] BD0	STIN[n] SMP1	STIN[n] SMP0	0	0	0	STIN[n] EN
Bit	Name	Description														
15 - 9	Unused	<b>Reserved</b> In normal functional mode, these bits <b>MUST</b> be set to zero.														
8 - 6	STIN[n]BD2 - 0	<b>Input Stream[n] Bit Delay Bits.</b> The binary value of these bits refers to the number of bits that the input stream will be delayed relative to FPi. The maximum value is 7. Zero means no delay.														
5 - 4	STIN[n]SMP1 - 0	<b>Input Data Sampling Point Selection Bits</b>														
		STIN[n]SMP1-0			Sampling Point (2.048 Mbps, 4.096 Mbps, 8.192 Mbps streams)				Sampling Point 16.384 Mbps streams)							
		00			3/4 point				1/2 point							
		01			1/4 point											
		10			2/4 point				4/4 point							
		11			4/4 point											
3 - 1	Unused	<b>Reserved</b> In normal functional mode, these bits <b>MUST</b> be set to zero.														

Table 10 - Stream Input Control Register 0 - 15 (SICR0 - 15) Bits

External Read/Write Address: 0100 <sub>H</sub> - 010F <sub>H</sub> Reset Value: 0000 <sub>H</sub>																
15	14	13	12	11	10	9	8	7	6	5	4	3	2	1	0	
0	0	0	0	0	0	0	0	STIN[n] BD2	STIN[n] BD1	STIN[n] BD0	STIN[n] SMP1	STIN[n] SMP0	0	0	0	STIN[n] EN
Bit	Name		Description													
0	STIN[n]EN		<b>Input Stream Enable Bit</b> When this bit is high the input stream is enabled. When this bit is low the input stream is ignored													
Note: [n] denotes input stream from 0 - 15.																

**Table 10 - Stream Input Control Register 0 - 15 (SICR0 - 15) Bits (continued)**

External Read/Write Address: 0200 <sub>H</sub> - 020F <sub>H</sub> Reset Value: 0000 <sub>H</sub>																
15	14	13	12	11	10	9	8	7	6	5	4	3	2	1	0	
0	0	0	0	0	0	0	0	STO[n] FA1	STO[n] FA0	STO[n] AD2	STO[n] AD1	STO[n] AD0	0	0	0	STO[n] EN
Bit	Name		Description													
15 - 9	Unused		<b>Reserved</b> In normal functional mode, these bits <b>MUST</b> be set to zero.													
8 - 7	STO[n]FA1 - 0		<b>Output Stream[n] Fractional Advancement Bits</b>													
			STO[n]FA1-0				Advancement (2.048 Mbps, 4.096 Mbps, 8.192 Mbps streams)					Advancement (16.384 Mbps streams)				
			00				0					0				
			01				1/4 bit					2/4				
			10				2/4 bit					Reserved				
			11				3/4 bit									
6 - 4	STO[n]AD2 - 0		<b>Output Stream[n] Bit Advancement Selection Bits</b> The binary value of these bits refers to the number of bits that the output stream is to be advanced relative to FPi. The maximum value is 7. Zero means no advancement.													
3 - 1	Unused		<b>Reserved</b> In normal functional mode, these bits <b>MUST</b> be set to zero.													
0	STO[n]EN		<b>Output Stream Enable Bit</b> When this bit is high the output stream is enabled. When this bit is low the output stream is set to high impedance													
Note: [n] denotes output stream from 0 - 15.																

**Table 11 - Stream Output Control Register 0 - 15 (SOCR0 - 15) Bits**

**15.0 Memory**

**15.1 Memory Address Mappings**

When A13 is high, the data or connection memory can be accessed by the microprocessor port. Bit 1 - 0 in the Control Register determine the access to the data or connection memory (CM\_L or CM\_H).

MSB (Note 1)	Stream Address (St0 - 15)						Channel Address (Ch0 - 255)									
	A13	A12	A11	A10	A9	A8	Stream [n]	A7	A6	A5	A4	A3	A2	A1	A0	Channel [n]
1	0	0	0	0	0	0	Stream 0	0	0	0	0	0	0	0	0	Ch 0
1	0	0	0	0	0	1	Stream 1	0	0	0	0	0	0	0	1	Ch 1
1	0	0	0	0	1	0	Stream 2	.	.	.	.	.	.	.	.	.
1	0	0	0	0	1	1	Stream 3	.	.	.	.	.	.	.	.	.
1	0	0	0	1	0	0	Stream 4	0	0	0	1	1	1	1	0	Ch 30
1	0	0	0	1	0	1	Stream 5	0	0	0	1	1	1	1	1	Ch 31 (Note 2)
1	0	0	0	1	1	0	Stream 6	0	0	1	0	0	0	0	0	Ch 32
1	0	0	0	1	1	1	Stream 7	0	0	1	0	0	0	0	1	Ch 33
1	0	1	0	0	0	0	Stream 8	.	.	.	.	.	.	.	.	.
.	.	.	.	.	.	.	.	.	.	.	.	.	.	.	.	.
.	.	.	.	.	.	.	.	0	0	1	1	1	1	1	0	Ch 62
.	.	.	.	.	.	.	.	0	0	1	1	1	1	1	1	Ch 63 (Note 3)
.	.	.	.	.	.	.	.	.	.	.	.	.	.	.	.	.
.	.	.	.	.	.	.	.	.	.	.	.	.	.	.	.	.
1	0	1	1	1	1	0	Stream 14	0	1	1	1	1	1	1	0	Ch126
1	0	1	1	1	1	1	Stream 15	0	1	1	1	1	1	1	1	Ch 127 (Note 4)
.	.	.	.	.	.	.	.	.	.	.	.	.	.	.	.	.
.	.	.	.	.	.	.	.	.	.	.	.	.	.	.	.	.
.	.	.	.	.	.	.	.	.	.	.	.	.	.	.	.	.
.	.	.	.	.	.	.	.	.	.	.	.	.	.	.	.	.
.	.	.	.	.	.	.	.	1	1	1	1	1	1	1	0	Ch 254
.	.	.	.	.	.	.	.	1	1	1	1	1	1	1	1	Ch 255 (Note 5)

Notes:  
 1. A13 must be high for access to data and connection memory positions. A13 must be low to access internal registers.  
 2. Channels 0 to 31 are used when serial stream is at 2.048 Mbps.  
 3. Channels 0 to 63 are used when serial stream is at 4.096 Mbps.  
 4. Channels 0 to 127 are used when serial stream is at 8.192 Mbps.  
 5. Channels 0 to 255 are used when serial stream is at 16.384 Mbps.

**Table 12 - Address Map for Memory Locations (A13 = 1)**

## 15.2 Connection Memory Low (CM\_L) Bit Assignment

When the CMM bit (bit 0) in the connection memory low is zero, the per-channel transmission is set to the normal channel-switching. The connection memory low bit assignment for the channel transmission mode is shown in Table 13 on page 35.

15	14	13	12	11	10	9	8	7	6	5	4	3	2	1	0
0	V $\bar{C}$	0	SSA 3	SSA 2	SSA 1	SSA 0	SCA 7	SCA 6	SCA 5	SCA 4	SCA 3	SCA 2	SCA 1	SCA 0	<b>CMM =0</b>
Bit	Name	Description													
15	Unused	<b>Reserved</b> In normal functional mode, these bits <b>MUST</b> be set to zero.													
14	V $\bar{C}$	<b>Variable/Constant Delay Control</b> When this bit is low, the output data for this channel will be taken from constant delay memory. When this bit is set to high, the output data for this channel will be taken from variable delay memory. Note that VAREN must be set in Control Register first.													
13	Unused	<b>Reserved.</b> In normal functional mode, this bit <b>MUST</b> be set to zero.													
12 - 9	SSA3 - 0	<b>Source Stream Address</b> The binary value of these 4 bits represents the input stream number.													
8 - 1	SCA7 - 0	<b>Source Channel Address</b> The binary value of these 8 bits represents the input channel number.													
0	CMM = 0	<b>Connection Memory Mode = 0</b> If this is low, the connection memory is in the normal switching mode. Bit 13 - 1 are the source stream number and channel number.													

**Table 13 - Connection Memory Low (CM\_L) Bit Assignment when CMM = 0**

When CMM is one, the device is programmed to perform one of the special per-channel transmission modes. Bits PCC0 and PCC1 from connection memory are used to select the per-channel tristate or message mode as shown in Table 14 on page 36.

	15	14	13	12	11	10	9	8	7	6	5	4	3	2	1	0
	0	0	0	0	0	MSG 7	MSG 6	MSG 5	MSG 4	MSG 3	MSG 2	MSG 1	MSG 0	PCC 1	PCC 0	<b>CMM =1</b>

Bit	Name	Description															
15 - 11	Unused	<b>Reserved</b> In normal functional mode, these bits <b>MUST</b> be set to zero.															
10 - 3	MSG7 - 0	<b>Message Data Bits</b> 8-bit data for the message mode. Not used in the per-channel tristate.															
2 - 1	PCC1 - 0	<b>Per-Channel Control Bits</b> These two bits control the corresponding entry's value on the STio stream. <table border="1" style="margin: 10px auto; border-collapse: collapse; text-align: center;"> <thead> <tr> <th style="width: 5%;">PC C1</th> <th style="width: 5%;">PC C0</th> <th style="width: 90%;">Channel Output Mode</th> </tr> </thead> <tbody> <tr> <td>0</td> <td>0</td> <td>Per Channel Tristate</td> </tr> <tr> <td>0</td> <td>1</td> <td>Message Mode</td> </tr> <tr> <td>1</td> <td>0</td> <td>Reserved</td> </tr> <tr> <td>1</td> <td>1</td> <td>Reserved</td> </tr> </tbody> </table>	PC C1	PC C0	Channel Output Mode	0	0	Per Channel Tristate	0	1	Message Mode	1	0	Reserved	1	1	Reserved
PC C1	PC C0	Channel Output Mode															
0	0	Per Channel Tristate															
0	1	Message Mode															
1	0	Reserved															
1	1	Reserved															
0	CMM = 1	<b>Connection Memory Mode = 1</b> If this is high, the connection memory is in the per-channel control mode which is per-channel tristate or per-channel message mode.															

**Table 14 - Connection Memory Low (CM\_L) Bit Assignment when CMM = 1**

## 16.0 DC Parameters

### Absolute Maximum Ratings\*

	Parameter	Symbol	Min.	Max.	Units
1	I/O Supply Voltage	$V_{DD\_IO}$	-0.5	5.0	V
2	Core Supply Voltage	$V_{DD\_CORE}$	-0.5	2.5	V
3	Input Voltage	$V_{I\_3V}$	-0.5	$V_{DD} + 0.5$	V
4	Input Voltage (5 V-tolerant inputs)	$V_{I\_5V}$	-0.5	7.0	V
5	Continuous Current at Digital Outputs	$I_o$		15	mA
6	Package Power Dissipation	$P_D$		1.5	W
7	Storage Temperature	$T_S$	- 55	+125	°C

\* Exceeding these values may cause permanent damage. Functional operation under these conditions is not implied.

### Recommended Operating Conditions - Voltages are with respect to ground ( $V_{SS}$ ) unless otherwise stated.

	Characteristics	Sym.	Min.	Typ.‡	Max.	Units
1	Operating Temperature	$T_{OP}$	-40	25	+85	°C
2	Positive Supply	$V_{DD\_IO}$	3.0	3.3	3.6	V
3	Positive Supply	$V_{DD\_CORE}$	1.71	1.8	1.89	V
4	Input Voltage	$V_I$	0	3.3	$V_{DD\_IO}$	V
5	Input Voltage on 5 V-Tolerant Inputs	$V_{I\_5V}$	0	5.0	5.5	V

‡ Typical figures are at 25°C and are for design aid only: not guaranteed and not subject to production testing.

### DC Electrical Characteristics† - Voltages are with respect to ground ( $V_{SS}$ ) unless otherwise stated.

	Characteristics	Sym.	Min.	Typ.‡	Max.	Units	Test Conditions
1	Supply Current - $V_{DD\_CORE}$	$I_{DD\_CORE}$			75	mA	
2	Supply Current - $V_{DD\_IO}$	$I_{DD\_IO}$			40	mA	$C_L=30pF$
3	Input High Voltage	$V_{IH}$	2.0			V	
4	Input Low Voltage	$V_{IL}$			0.8	V	
5	Input Leakage (input pins) Input Leakage (bi-directional pins)	$I_{IL}$ $I_{BL}$			5 5	$\mu A$ $\mu A$	$0 \leq V_{IN} \leq V_{DD\_IO}$ See Note 1
6	Weak Pullup Current	$I_{PU}$		-33		$\mu A$	Input at 0 V
7	Weak Pulldown Current	$I_{PD}$		33		$\mu A$	Input at $V_{DD\_IO}$
8	Input Pin Capacitance	$C_I$		3		pF	
9	Output High Voltage	$V_{OH}$	2.4			V	$I_{OH} = 8 \text{ mA}$
10	Output Low Voltage	$V_{OL}$			0.4	V	$I_{OL} = 8 \text{ mA}$
11	Output High Impedance Leakage	$I_{OZ}$			5	$\mu A$	$0 < V < V_{DD}$
12	Output Pin Capacitance	$C_O$		5	10	pF	

† Characteristics are over recommended operating conditions unless otherwise stated.

‡ Typical figures are at 25°C,  $V_{DD\_CORE}$  at 1.8 V and  $V_{DD\_IO}$  at 3.3 V and are for design aid only: not guaranteed and not subject to production testing.

\* Note 1: Maximum leakage on pins (output or I/O pins in high impedance state) is over an applied voltage ( $V_{IN}$ ).

17.0 AC Parameters

AC Electrical Characteristics<sup>†</sup> - Timing Parameter Measurement Voltage Levels

	Characteristics	Sym.	Level	Units	Conditions
1	CMOS Threshold	$V_{CT}$	$0.5 V_{DD\_IO}$	V	
2	Rise/Fall Threshold Voltage High	$V_{HM}$	$0.7 V_{DD\_IO}$	V	
3	Rise/Fall Threshold Voltage Low	$V_{LM}$	$0.3 V_{DD\_IO}$	V	

<sup>†</sup> Characteristics are over recommended operating conditions unless otherwise stated.

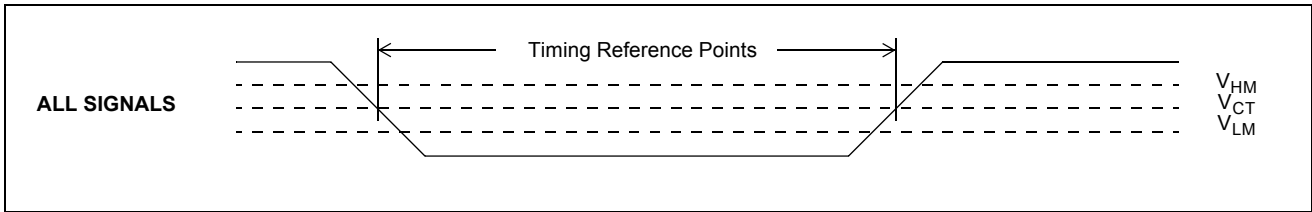

Figure 14 - Timing Parameter Measurement Voltage Levels

**AC Electrical Characteristics<sup>†</sup> - Motorola Non-Multiplexed Bus Mode - Read Access**

	Characteristics	Sym.	Min.	Typ. <sup>‡</sup>	Max.	Units	Test Conditions <sup>2</sup>
1	$\overline{CS}$ de-asserted time	$t_{CSD}$	15			ns	
2	$\overline{DS}$ de-asserted time	$t_{DSD}$	15			ns	
3	$\overline{CS}$ setup to $\overline{DS}$ falling	$t_{CSS}$	0			ns	
4	R/W setup to $\overline{DS}$ falling	$t_{RWS}$	10			ns	
5	Address setup to $\overline{DS}$ falling	$t_{AS}$	5			ns	
6	$\overline{CS}$ hold after $\overline{DS}$ rising	$t_{CSH}$	0			ns	
7	R/W hold after $\overline{DS}$ rising	$t_{RWH}$	0			ns	
8	Address hold after $\overline{DS}$ rising	$t_{AH}$	0			ns	
9	Data setup to $\overline{DTA}$ Low	$t_{DS}$	8			ns	$C_L = 50$ pF
10	Data Active to High Impedance	$t_{DHZ}$			8	ns	$C_L = 50$ pF, $R_L = 1$ K (Note 1)
11	Acknowledgement delay time. From $\overline{DS}$ low to $\overline{DTA}$ low: Registers Memory	$t_{AKD}$			75 185	ns ns	$C_L = 50$ pF $C_L = 50$ pF
12	Acknowledgement hold time. From $\overline{DS}$ high to $\overline{DTA}$ high	$t_{AKH}$	4		12	ns	$C_L = 50$ pF, $R_L = 1$ K (Note 1)
13	$\overline{DTA}$ drive high to HiZ	$t_{AKZ}$			8	ns	

Note 1: High impedance is measured by pulling to the appropriate rail with  $R_L$ , with timing corrected to cancel time taken to discharge  $C_L$ .

Note 2: A delay of 500  $\mu$ s to 2 ms (see Section 11.2 on page 25) must be applied before the first microprocessor access is performed after the RESET pin is set high.

<sup>†</sup> Characteristics are over recommended operating conditions unless otherwise stated.

<sup>‡</sup> Typical figures are at 25°C, VDD\_CORE at 1.8 V and VDD\_IO at 3.3 V and are for design aid only: not guaranteed and not subject to production testing.

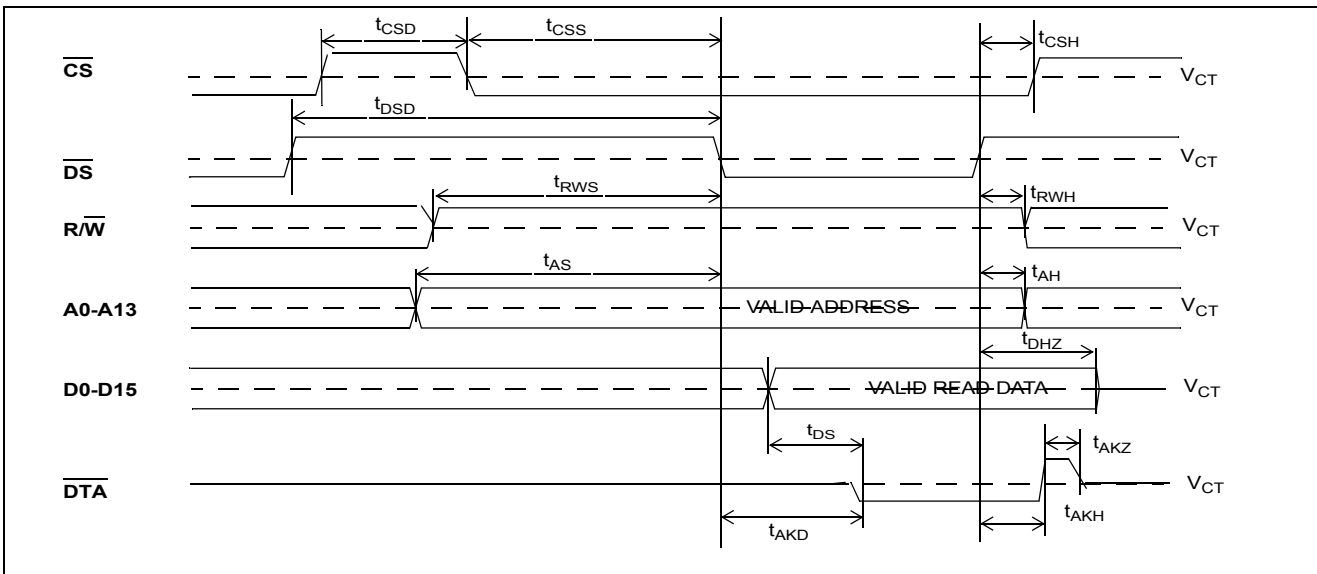

**Figure 15 - Motorola Non-Multiplexed Bus Timing - Read Access**

**AC Electrical Characteristics<sup>†</sup> - Motorola Non-Multiplexed Bus Mode - Write Access**

	Characteristics	Sym.	Min.	Typ. <sup>‡</sup>	Max.	Units	Test Conditions <sup>2</sup>
1	$\overline{CS}$ de-asserted time	$t_{CSD}$	15			ns	
2	$\overline{DS}$ de-asserted time	$t_{DSD}$	15			ns	
3	$\overline{CS}$ setup to $\overline{DS}$ falling	$t_{CSS}$	0			ns	
4	R/W setup to $\overline{DS}$ falling	$t_{RWS}$	10			ns	
5	Address setup to $\overline{DS}$ falling	$t_{AS}$	5			ns	
6	Data setup to $\overline{DS}$ falling	$t_{DS}$	0			ns	$C_L = 50$ pF
7	$\overline{CS}$ hold after $\overline{DS}$ rising	$t_{CSH}$	0			ns	
8	R/W hold after $\overline{DS}$ rising	$t_{RWH}$	0			ns	
9	Address hold after $\overline{DS}$ rising	$t_{AH}$	0			ns	
10	Data hold from $\overline{DS}$ rising	$t_{DH}$	5			ns	$C_L = 50$ pF, $R_L = 1$ K (Note 1)
11	Acknowledgement delay time. From $\overline{DS}$ low to DTA low: Registers Memory	$t_{AKD}$			55 150	ns ns	$C_L = 50$ pF $C_L = 50$ pF
12	Acknowledgement hold time. From $\overline{DS}$ high to DTA high	$t_{AKH}$	4		12	ns	$C_L = 50$ pF, $R_L = 1$ K (Note 1)
13	DTA drive high to HiZ	$t_{AKZ}$			8	ns	

Note 1: High impedance is measured by pulling to the appropriate rail with  $R_L$ , with timing corrected to cancel time taken to discharge  $C_L$ .

Note 2: A delay of 500  $\mu$ s to 2 ms (see Section 11.2 on page 25) must be applied before the first microprocessor access is performed after the RESET pin is set high.

<sup>†</sup> Characteristics are over recommended operating conditions unless otherwise stated.

<sup>‡</sup> Typical figures are at 25°C, VDD\_CORE at 1.8 V and VDD\_IO at 3.3 V and are for design aid only: not guaranteed and not subject to production testing.

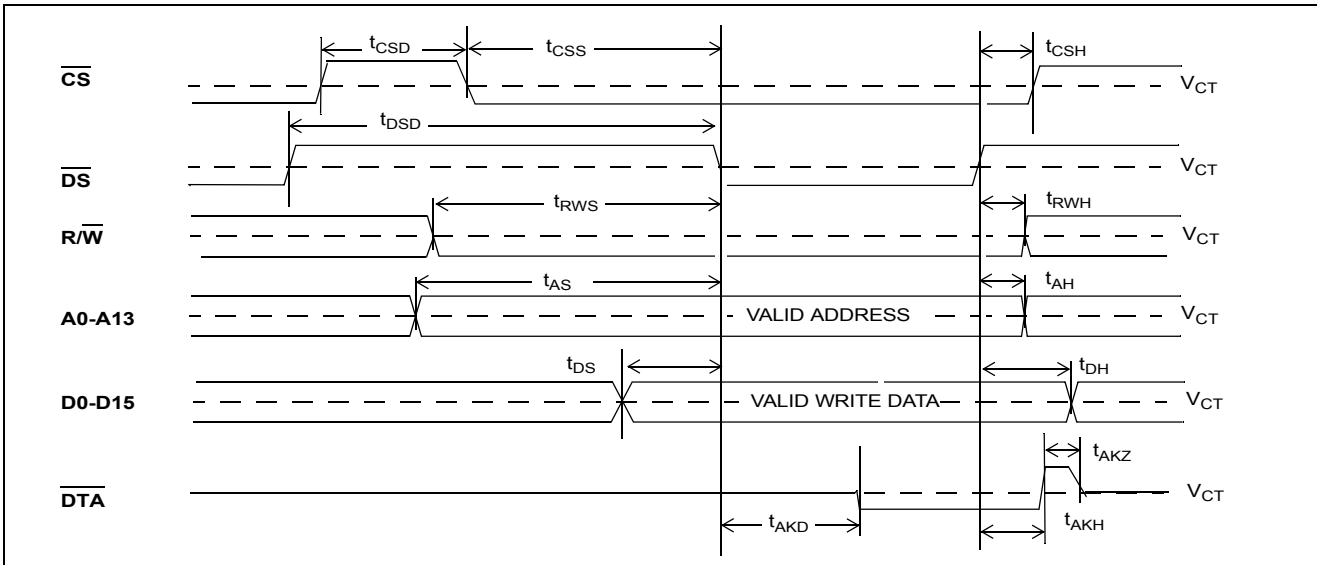

**Figure 16 - Motorola Non-Multiplexed Bus Timing - Write Access**

**AC Electrical Characteristics<sup>†</sup> - Intel Non-Multiplexed Bus Mode - Read Access**

	Characteristics	Sym.	Min.	Typ. <sup>‡</sup>	Max.	Units	Test Conditions <sup>2</sup>
1	$\overline{\text{CS}}$ de-asserted time	$t_{\text{CSD}}$	15			ns	
2	$\overline{\text{RD}}$ setup to $\overline{\text{CS}}$ falling	$t_{\text{RS}}$	10			ns	
3	$\overline{\text{WR}}$ setup to $\overline{\text{CS}}$ falling	$t_{\text{WS}}$	10			ns	
4	Address setup to $\overline{\text{CS}}$ falling	$t_{\text{AS}}$	5			ns	
5	$\overline{\text{RD}}$ hold after $\overline{\text{CS}}$ rising	$t_{\text{RH}}$	0			ns	
6	$\overline{\text{WR}}$ hold after $\overline{\text{CS}}$ rising	$t_{\text{WH}}$	0			ns	
7	Address hold after $\overline{\text{CS}}$ rising	$t_{\text{AH}}$	0			ns	
8	Data setup to RDY high	$t_{\text{DS}}$	8			ns	$C_L = 50 \text{ pF}$
9	Data Active to High Impedance	$t_{\text{CSZ}}$	7			ns	$C_L = 50 \text{ pF}, R_L = 1 \text{ K}$ (Note 1)
10	Acknowledgement delay time. From $\overline{\text{CS}}$ low to RDY high: Registers Memory	$t_{\text{AKD}}$			175 185	ns ns	$C_L = 50 \text{ pF}$ $C_L = 50 \text{ pF}$
11	Acknowledgement hold time. From $\overline{\text{CS}}$ high to RDY low	$t_{\text{AKH}}$	4		12	ns	$C_L = 50 \text{ pF}, R_L = 1 \text{ K}$ (Note 1)
12	RDY drive low to HiZ	$t_{\text{AKZ}}$			8	ns	

Note 1: High impedance is measured by pulling to the appropriate rail with  $R_L$ , with timing corrected to cancel time taken to discharge  $C_L$ .

Note 2: A delay of 500  $\mu\text{s}$  to 2 ms (see Section 11.2 on page 25) must be applied before the first microprocessor access is performed after the RESET pin is set high.

<sup>†</sup> Characteristics are over recommended operating conditions unless otherwise stated.

<sup>‡</sup> Typical figures are at 25°C, VDD\_CORE at 1.8 V and VDD\_IO at 3.3 V and are for design aid only: not guaranteed and not subject to production testing.

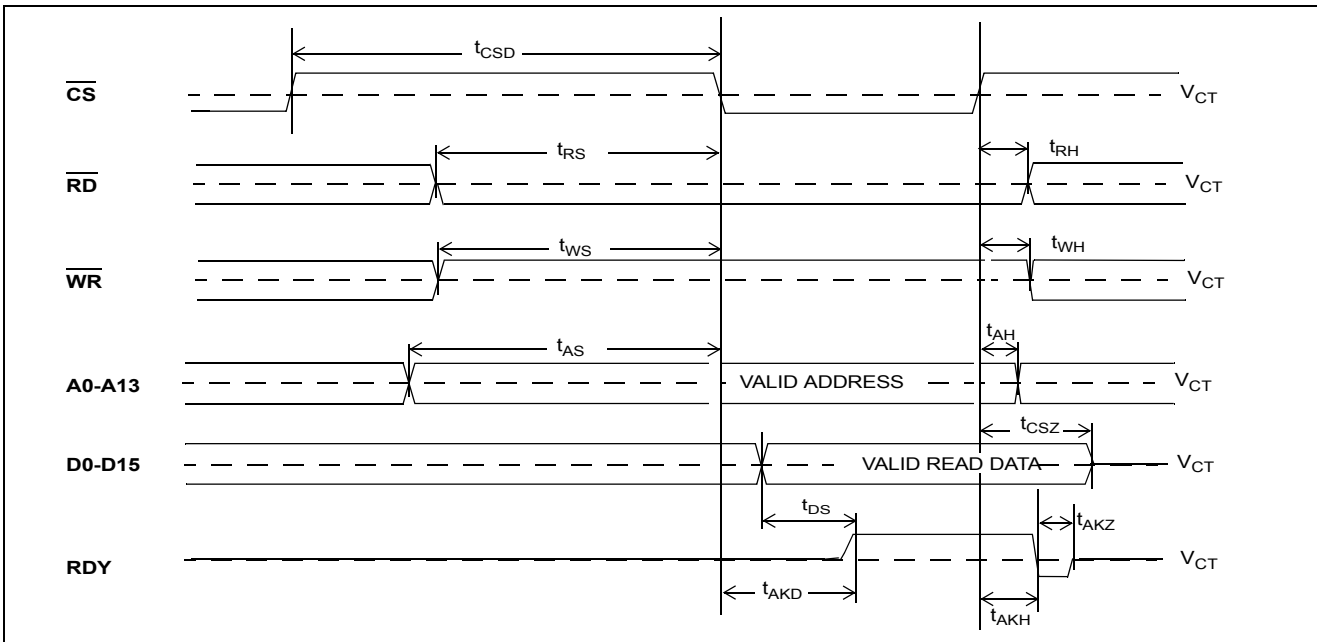

**Figure 17 - Intel Non-Multiplexed Bus Timing - Read Access**

**AC Electrical Characteristics<sup>†</sup> - Intel Non-Multiplexed Bus Mode - Write Access**

	Characteristics	Sym.	Min.	Typ. <sup>‡</sup>	Max.	Units	Test Conditions <sup>2</sup>
1	$\overline{\text{CS}}$ de-asserted time	$t_{\text{CSD}}$	15			ns	
2	$\overline{\text{WR}}$ setup to $\overline{\text{CS}}$ falling	$t_{\text{WS}}$	10			ns	
3	$\overline{\text{RD}}$ setup to $\overline{\text{CS}}$ falling	$t_{\text{RS}}$	10			ns	
4	Address setup to $\overline{\text{CS}}$ falling	$t_{\text{AS}}$	5			ns	
5	Data setup to $\overline{\text{CS}}$ falling	$t_{\text{DS}}$	0			ns	$C_L = 50 \text{ pF}$
6	$\overline{\text{WR}}$ hold after $\overline{\text{CS}}$ rising	$t_{\text{WH}}$	0			ns	
7	$\overline{\text{RD}}$ hold after $\overline{\text{CS}}$ rising	$t_{\text{RH}}$	0			ns	
8	Address hold after $\overline{\text{CS}}$ rising	$t_{\text{AH}}$	10			ns	
9	Data hold after $\overline{\text{CS}}$ rising	$t_{\text{DH}}$	5			ns	$C_L = 50 \text{ pF}, R_L = 1 \text{ K}$ (Note 1)
10	Acknowledgement delay time. From $\overline{\text{CS}}$ low to RDY high: Registers Memory	$t_{\text{AKD}}$			55 150	ns ns	$C_L = 50 \text{ pF}$ $C_L = 50 \text{ pF}$
11	Acknowledgement hold time. From $\overline{\text{CS}}$ high to RDY low	$t_{\text{AKH}}$	4		12	ns	$C_L = 50 \text{ pF}, R_L = 1 \text{ K}$ (Note 1)
12	RDY drive low to HiZ	$t_{\text{AKZ}}$			8	ns	

Note 1: High impedance is measured by pulling to the appropriate rail with  $R_L$ , with timing corrected to cancel time taken to discharge  $C_L$ .

Note 2: A delay of  $500 \mu\text{s}$  to 2 ms (Section 11.2 on page 25) must be applied before the first microprocessor access is performed after the RESET pin is set high.

<sup>†</sup> Characteristics are over recommended operating conditions unless otherwise stated.

<sup>‡</sup> Typical figures are at 25°C, VDD\_CORE at 1.8 V and VDD\_IO at 3.3 V and are for design aid only: not guaranteed and not subject to production testing.

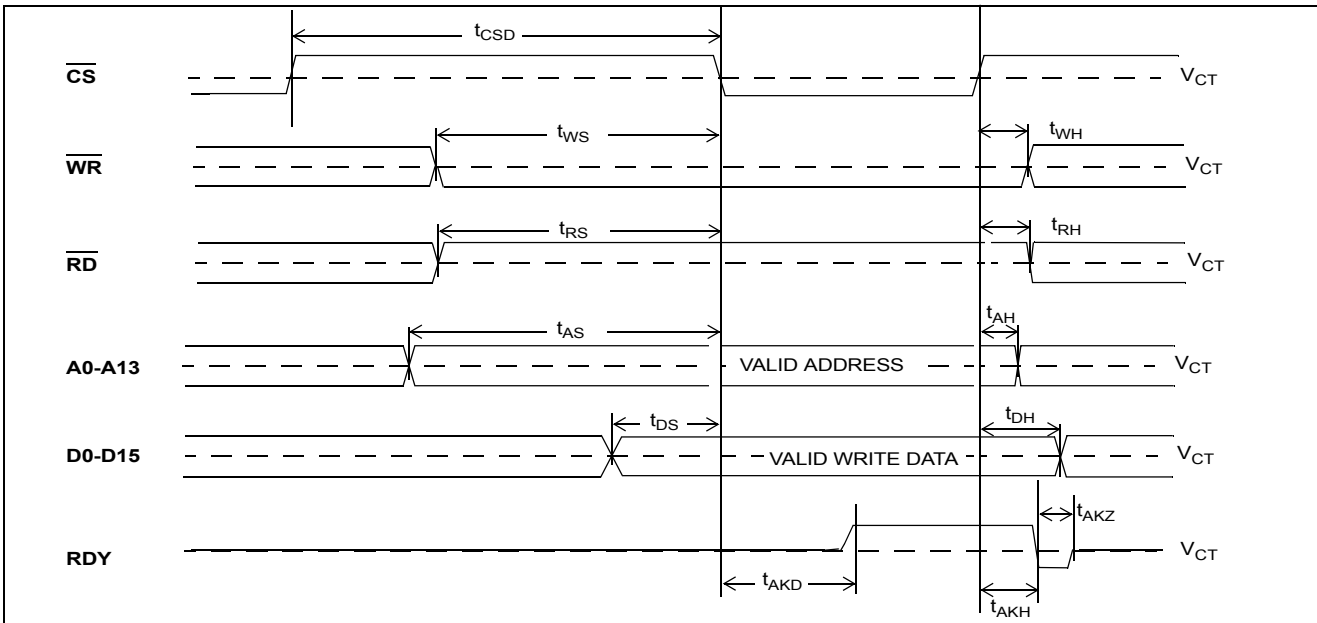

**Figure 18 - Intel Non-Multiplexed Bus Timing - Write Access**

**AC Electrical Characteristics<sup>†</sup> - JTAG Test Port Timing**

	Characteristic	Sym.	Min.	Typ. <sup>‡</sup>	Max.	Units	Notes
1	TCK Clock Period	$t_{TCKP}$	100			ns	
2	TCK Clock Pulse Width High	$t_{TCKH}$	20			ns	
3	TCK Clock Pulse Width Low	$t_{TCKL}$	20			ns	
4	TMS Set-up Time	$t_{TMSS}$	10			ns	
5	TMS Hold Time	$t_{TMSH}$	10			ns	
6	TDi Input Set-up Time	$t_{TDIS}$	20			ns	
7	TDi Input Hold Time	$t_{TDIH}$	60			ns	
8	TDo Output Delay	$t_{TDOD}$			30	ns	$C_L = 30 \text{ pF}$
9	TRST pulse width	$t_{TRSTW}$	200			ns	

<sup>†</sup> Characteristics are over recommended operating conditions unless otherwise stated.

<sup>‡</sup> Typical figures are at 25°C, VDD\_CORE at 1.8 V and VDD\_IO at 3.3 V and are for design aid only; not guaranteed and not subject to production testing.

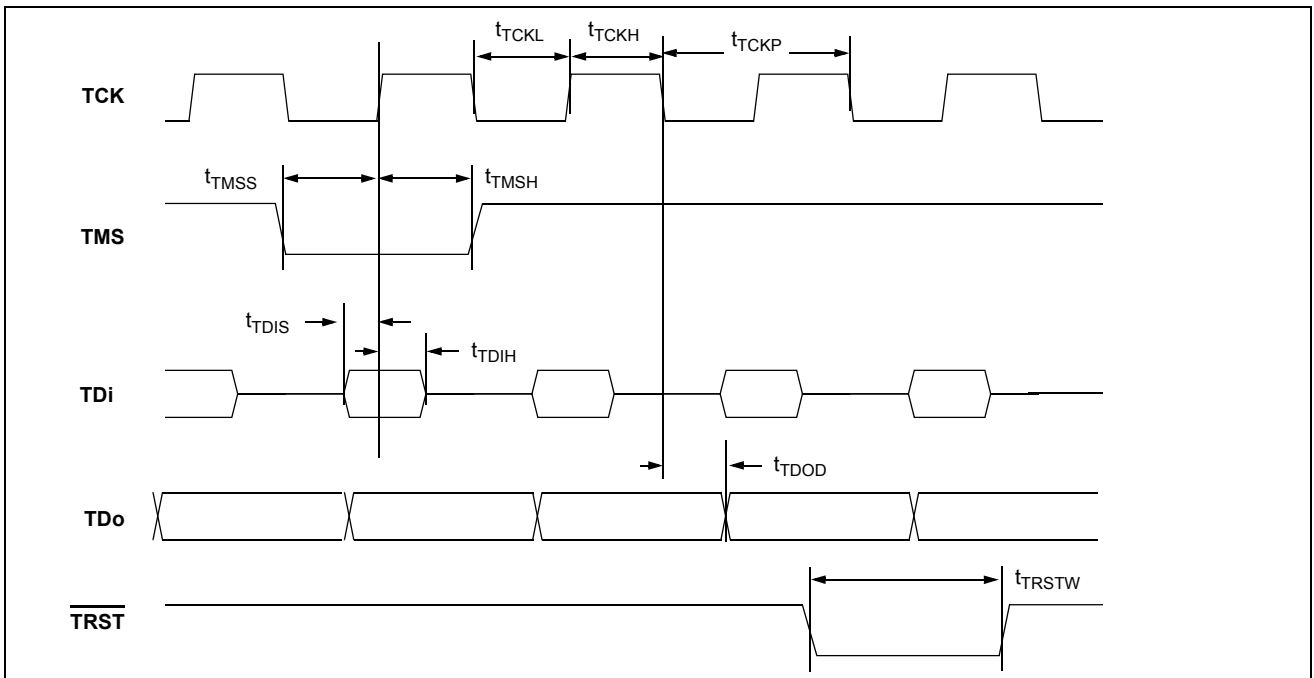

**Figure 19 - JTAG Test Port Timing Diagram**

**AC Electrical Characteristics<sup>†</sup> - FPi and CKi Timing when CKIN1-0 bits = 00 (16.384 MHz)**

	Characteristic	Sym.	Min.	Typ. <sup>‡</sup>	Max.	Units	Notes
1	FPi Input Frame Pulse Width	$t_{FPIW}$	40	61	115	ns	
2	FPi Input Frame Pulse Setup Time	$t_{FPIS}$	20			ns	
3	FPi Input Frame Pulse Hold Time	$t_{FPIH}$	20			ns	
4	CKi Input Clock Period	$t_{CKIP}$	55	61	67	ns	
5	CKi Input Clock High Time	$t_{CKIH}$	27		34	ns	
6	CKi Input Clock Low Time	$t_{CKIL}$	27		34	ns	
7	CKi Input Clock Rise/Fall Time	$t_{rCKi}, t_{fCKi}$			3	ns	
8	CKi Input Clock Cycle to Cycle Variation	$t_{CVC}$	0		20	ns	

<sup>†</sup> Characteristics are over recommended operating conditions unless otherwise stated.

<sup>‡</sup> Typical figures are at 25°C, VDD\_CORE at 1.8 V and VDD\_IO at 3.3 V and are for design aid only; not guaranteed and not subject to production testing.

**AC Electrical Characteristics<sup>†</sup> - FPi and CKi Timing when CKIN1-0 bits = 01 (8.192 MHz)**

	Characteristic	Sym.	Min.	Typ. <sup>‡</sup>	Max.	Units	Notes
1	FPi Input Frame Pulse Width	$t_{FPIW}$	90	122	220	ns	
2	FPi Input Frame Pulse Setup Time	$t_{FPIS}$	45			ns	
3	FPi Input Frame Pulse Hold Time	$t_{FPIH}$	45			ns	
4	CKi Input Clock Period	$t_{CKIP}$	110	122	135	ns	
5	CKi Input Clock High Time	$t_{CKIH}$	55		69	ns	
6	CKi Input Clock Low Time	$t_{CKIL}$	55		69	ns	
7	CKi Input Clock Rise/Fall Time	$t_{rCKi}, t_{fCKi}$			3	ns	
8	CKi Input Clock Cycle to Cycle Variation	$t_{CVC}$	0		20	ns	

<sup>†</sup> Characteristics are over recommended operating conditions unless otherwise stated.

<sup>‡</sup> Typical figures are at 25°C, VDD\_CORE at 1.8 V and VDD\_IO at 3.3 V and are for design aid only; not guaranteed and not subject to production testing.

**AC Electrical Characteristics<sup>†</sup> - FPi and CKi Timing when CKIN1-0 bits = 10 (4.096 MHz)**

	Characteristic	Sym.	Min.	Typ. <sup>‡</sup>	Max.	Units	Notes
1	FPi Input Frame Pulse Width	$t_{FPIW}$	90	244	420	ns	
2	FPi Input Frame Pulse Setup Time	$t_{FPIS}$	110			ns	
3	FPi Input Frame Pulse Hold Time	$t_{FPIH}$	110			ns	
4	CKi Input Clock Period	$t_{CKIP}$	220	244	270	ns	
5	CKi Input Clock High Time	$t_{CKIH}$	110		135	ns	
6	CKi Input Clock Low Time	$t_{CKIL}$	110		135	ns	
7	CKi Input Clock Rise/Fall Time	$t_{rCKi}, t_{fCKi}$			3	ns	
8	CKi Input Clock Cycle to Cycle Variation	$t_{CVC}$	0		20	ns	

<sup>†</sup> Characteristics are over recommended operating conditions unless otherwise stated.

<sup>‡</sup> Typical figures are at 25°C, VDD\_CORE at 1.8 V and VDD\_IO at 3.3 V and are for design aid only: not guaranteed and not subject to production testing.

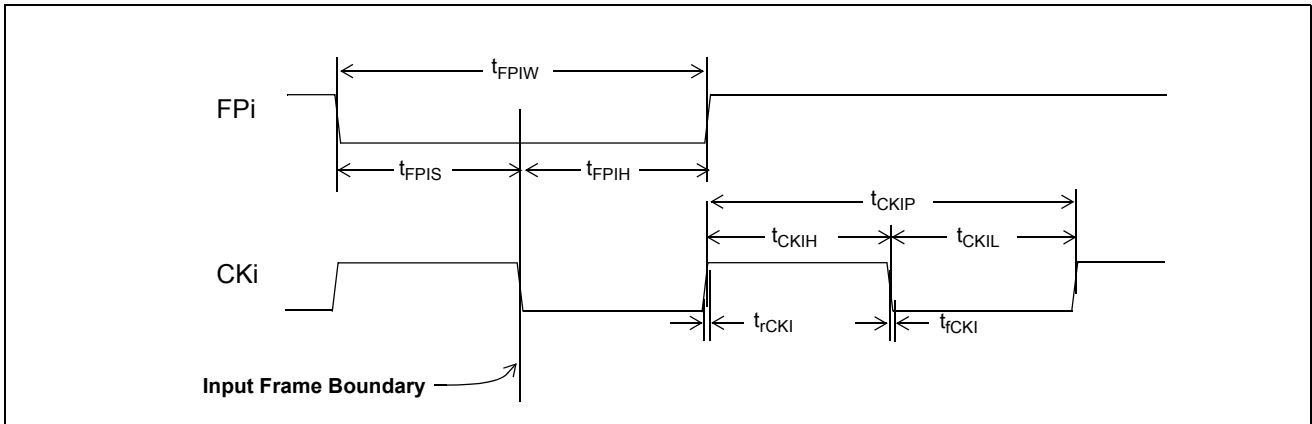

**Figure 20 - Frame Pulse Input and Clock Input Timing Diagram (ST-BUS)**

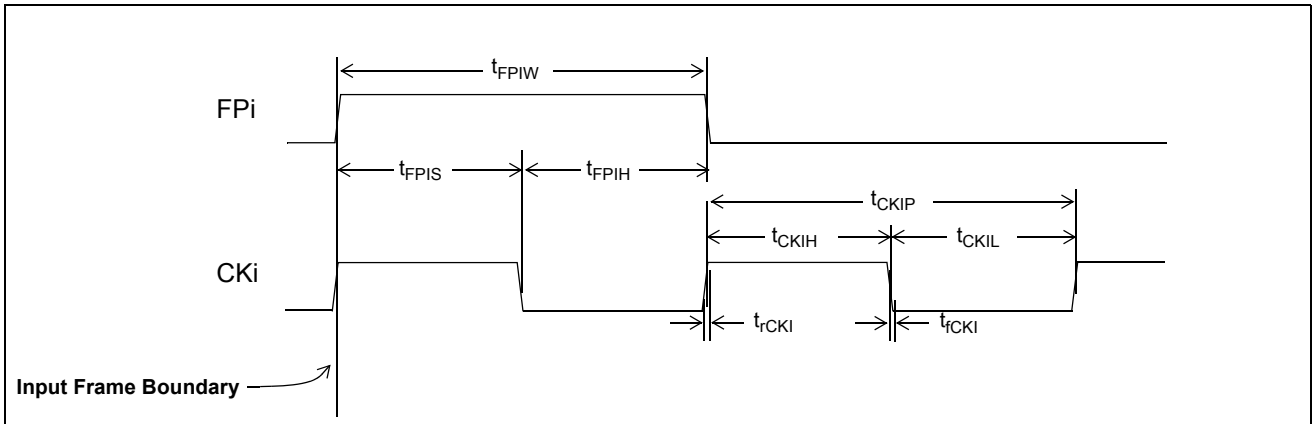

**Figure 21 - Frame Pulse Input and Clock Input Timing Diagram (GCI-Bus)**

**AC Electrical Characteristics<sup>†</sup> - ST-BUS/GCI-Bus Input Timing**

	Characteristic	Sym.	Min.	Typ. <sup>‡</sup>	Max.	Units	Test Conditions
1	STi Setup Time 2.048 Mbps 4.096 Mbps 8.192 Mbps 16.384 Mbps	$t_{SIS2}$ $t_{SIS4}$ $t_{SIS8}$ $t_{SIS16}$	5 5 5 5			ns ns ns ns	
2	STi Hold Time 2.048 Mbps 4.096 Mbps 8.192 Mbps 16.384 Mbps	$t_{SIH2}$ $t_{SIH4}$ $t_{SIH8}$ $t_{SIH16}$	8 8 8 8			ns ns ns ns	
3	STio Delay - Active to Active @2.048 Mbps @4.096 Mbps @8.192 Mbps @16.384 Mbps	$t_{SOD2}$ $t_{SOD4}$ $t_{SOD8}$ $t_{SOD16}$	-6 -6 -6 -6		0 0 0 0	ns ns ns ns	$C_L = 30 \text{ pF}$
4	STio Delay - Active to High-Z STio Delay - High-Z to Active  2.048 Mbps 4.096 Mbps 8.192 Mbps 16.384 Mbps	$t_{DZ}$ $t_{ZD}$	-8 -8 -8 -8		0 0 0 0	ns ns ns ns	$R_L = 1 \text{ k}$ , $C_L = 30 \text{ pF}$ , See Note 1.
5	Output Drive Enable (ODE) Delay - High-Z to Active	$t_{ZD\_ODE}$			260	ns	
6	Output Drive Enable (ODE) Delay - Active to High-Z	$t_{DZ\_ODE}$			260	ns	

<sup>†</sup> Characteristics are over recommended operating conditions unless otherwise stated.

<sup>‡</sup> Typical figures are at 25°C, VDD\_CORE at 1.8 V and VDD\_IO at 3.3 V and are for design aid only: not guaranteed and not subject to production testing.

Note 1: High impedance is measured by pulling to the appropriate rail with  $R_L$ , with timing corrected to cancel the time taken to discharge  $C_L$ .

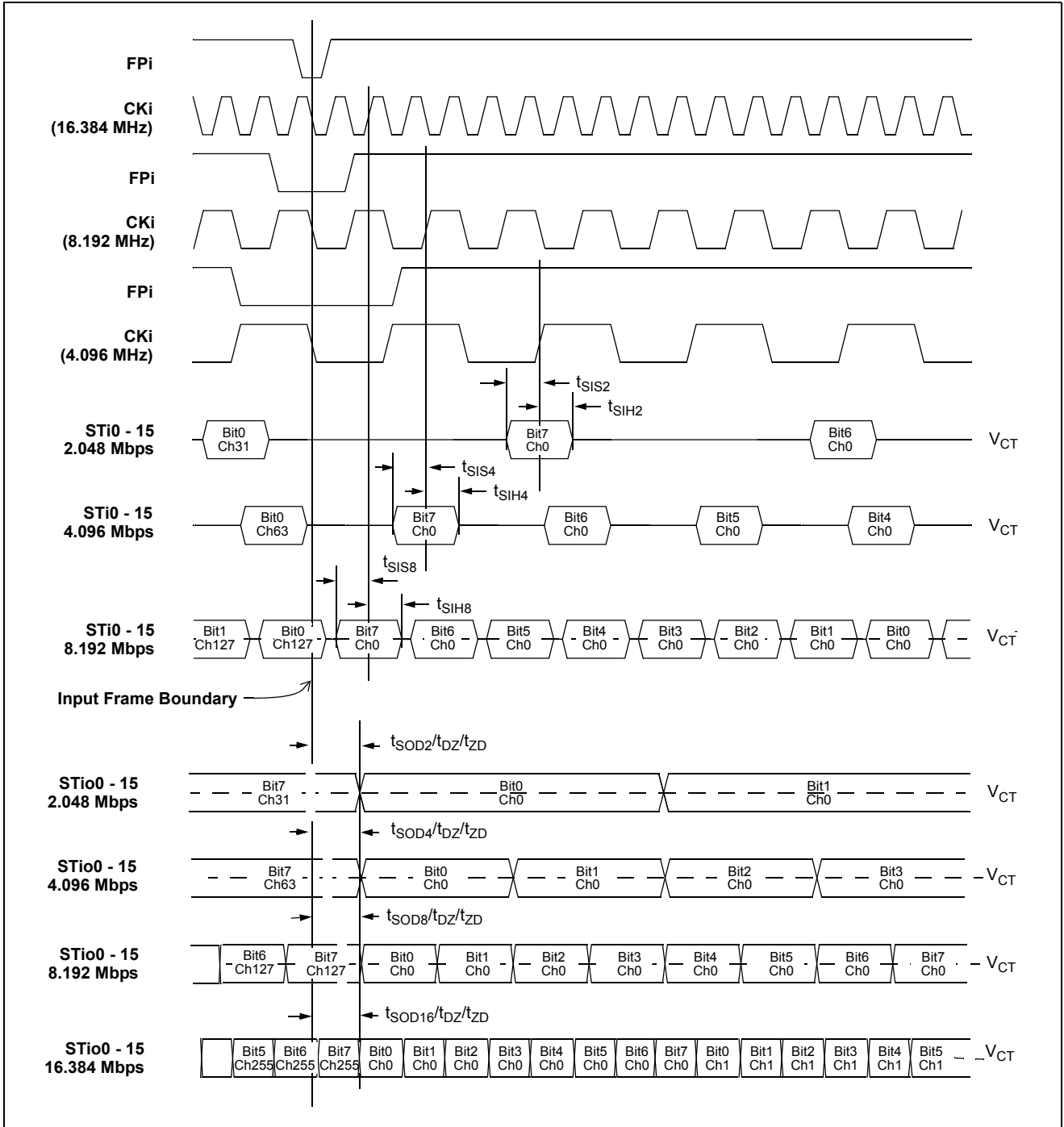

Figure 22 - ST-BUS Input and Output Timing Diagram when Operated at 2, 4, 8 and 16 Mbps

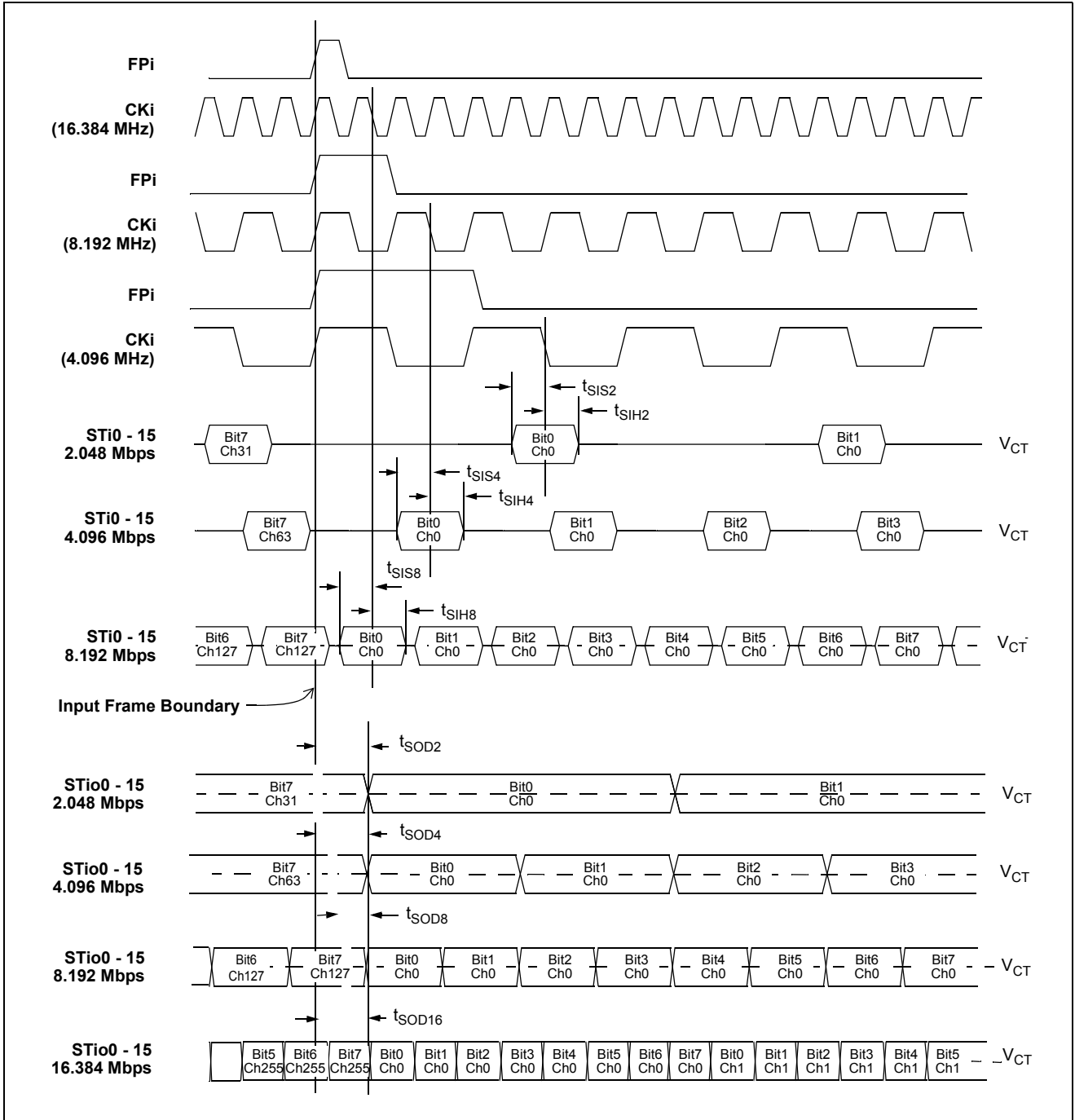
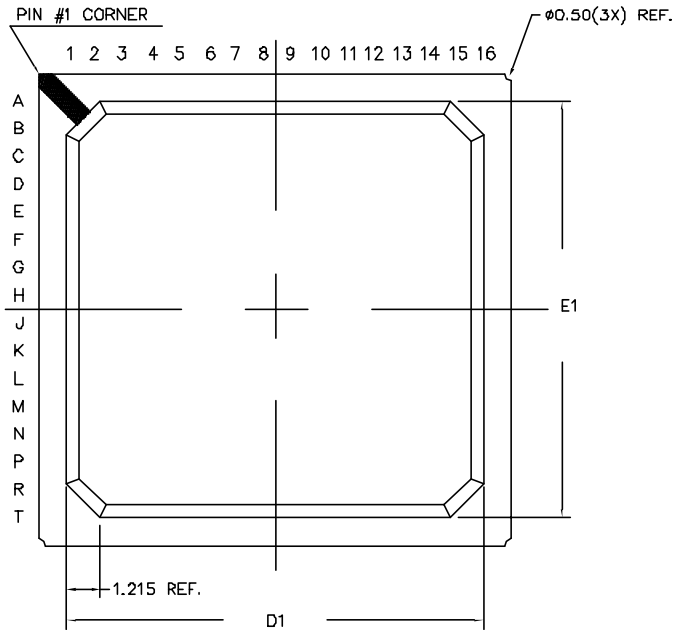
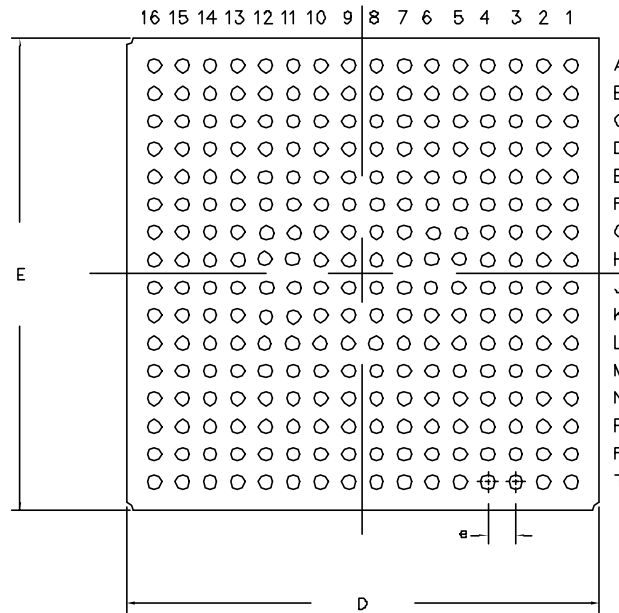

Figure 23 - GCI-Bus Input and Output Timing Diagram when Operated at 2, 4, 8 and 16 Mbps

TOP VIEW



BOTTOM VIEW



DIMENSION	MIN	MAX
A	1.42	1.80
A1	0.30	0.50
A2	0.85 REF	
D	16.80	17.20
D1	14.80	15.20
E	16.80	17.20
E1	14.80	15.20
b	0.40	0.60
e	1.00	
N	256	
Conforms to JEDEC MS-034		

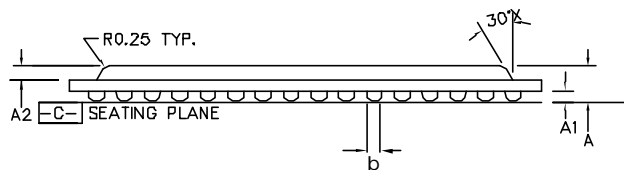

SIDE VIEW

NOTES: -

1. Controlling dimensions are in MM.
2. Seating plane is defined by the spherical crown of the solder balls.
3. Not to scale.
4. N is the number of solder balls
5. Substrate thickness is 0.36 MM.

© Zarlink Semiconductor 2003 All rights reserved.

ISSUE	1			
ACN	214440			
DATE	26June03			
APPRD.				



Previous package codes

BP/G

Package Code GA

Package Outline for  
256ball BGA  
17x17x1.61mm

GPD00842

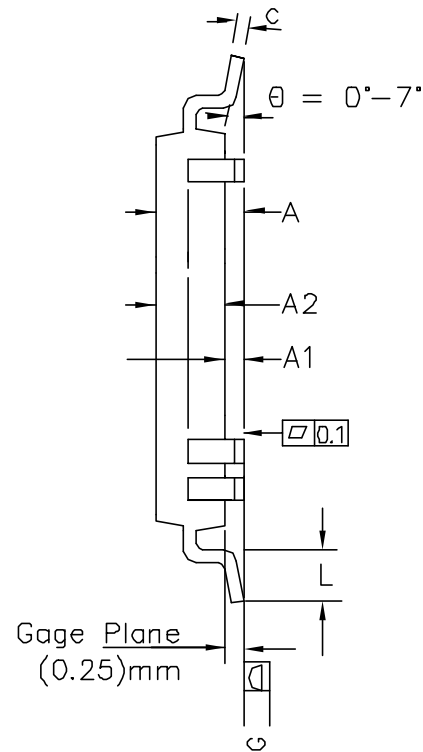
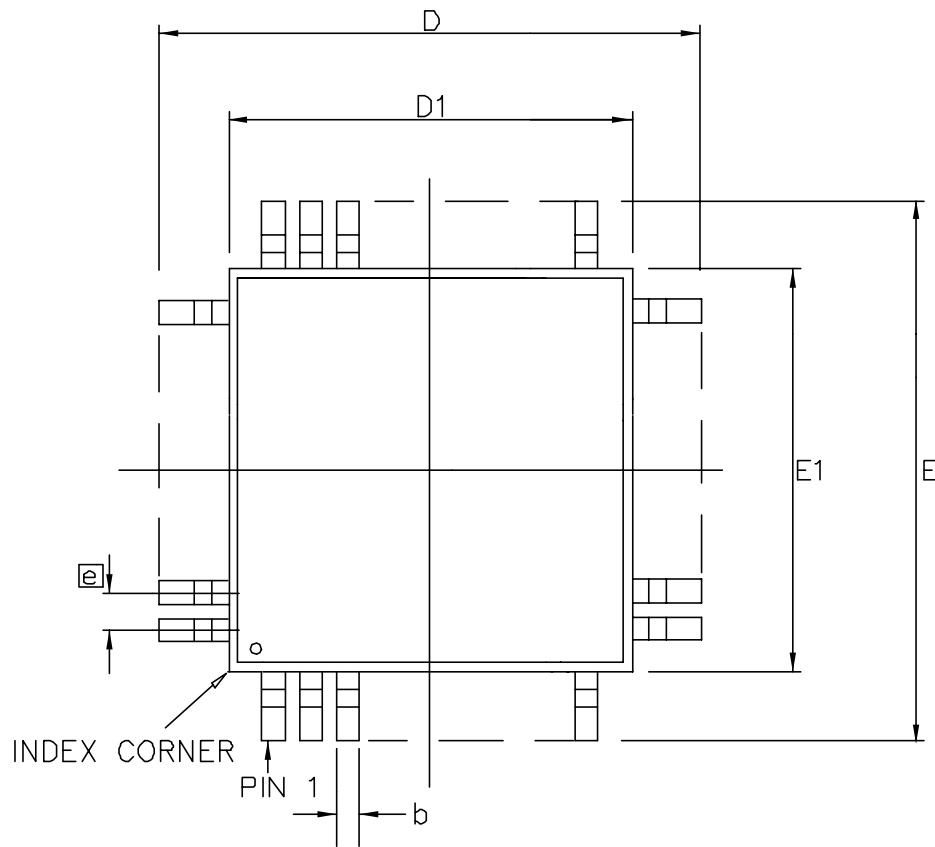

Symbol	Control Dimensions in millimetres		Altern. Dimensions in inches	
	MIN	MAX	MIN	MAX
A	—	1.60	—	0.063
A1	0.05	0.15	0.002	0.006
A2	1.35	1.45	0.053	0.057
D	30.00 BSC		1.181 BSC	
D1	28.00 BSC		1.102 BSC	
E	30.00 BSC		1.181 BSC	
E1	28.00 BSC		1.102 BSC	
L	0.45	0.75	0.018	0.029
e	0.40 BSC		0.016 BSC	
b	0.13	0.23	0.005	0.009
c	0.09	0.20	0.003	0.008
Pin features				
N	256			
ND	64			
NE	64			
NOTE	SQUARE			

Conforms to JEDEC MS-026 BJC Iss. D

- Notes:
1. Pin 1 indicator may be a corner chamfer, dot or both, located within a zone of dimension  $E1/4 \times D1/4$  from the index corner
  2. All dimensioning and tolerancing conform to ANSI Y14.5-1982.
  3. Dimensions D1 and E1 do not include mold protrusion – allowable mold protrusion is 0.254 mm on D1 and E1 dimensions.
  4. "N" is the total number of terminals
  5. Package top dimensions are smaller than bottom dimensions and top of package will not overhang bottom of package
  6. Dimension b does not include Dambar protrusion.
  7. Controlling Dimensions are in Millimeter
  8. A1 is defined as the distance from the seating plane to the lowest point of the package body

© Zarlink Semiconductor 2003 All rights reserved.						Package Code <b>QC</b>	
ISSUE	1	2	3	4		Previous package codes	Package Outline for 256 lead LQFP (28 x 28 x 1.4mm) 2.0mm Footprint
ACN	214172	214382				GP	
DATE	27Mar03	12June03					GPD00837
APPRD.							



**For more information about all Zarlink products  
visit our Web Site at  
[www.zarlink.com](http://www.zarlink.com)**

Information relating to products and services furnished herein by Zarlink Semiconductor Inc. or its subsidiaries (collectively "Zarlink") is believed to be reliable. However, Zarlink assumes no liability for errors that may appear in this publication, or for liability otherwise arising from the application or use of any such information, product or service or for any infringement of patents or other intellectual property rights owned by third parties which may result from such application or use. Neither the supply of such information or purchase of product or service conveys any license, either express or implied, under patents or other intellectual property rights owned by Zarlink or licensed from third parties by Zarlink, whatsoever. Purchasers of products are also hereby notified that the use of product in certain ways or in combination with Zarlink, or non-Zarlink furnished goods or services may infringe patents or other intellectual property rights owned by Zarlink.

This publication is issued to provide information only and (unless agreed by Zarlink in writing) may not be used, applied or reproduced for any purpose nor form part of any order or contract nor to be regarded as a representation relating to the products or services concerned. The products, their specifications, services and other information appearing in this publication are subject to change by Zarlink without notice. No warranty or guarantee express or implied is made regarding the capability, performance or suitability of any product or service. Information concerning possible methods of use is provided as a guide only and does not constitute any guarantee that such methods of use will be satisfactory in a specific piece of equipment. It is the user's responsibility to fully determine the performance and suitability of any equipment using such information and to ensure that any publication or data used is up to date and has not been superseded. Manufacturing does not necessarily include testing of all functions or parameters. These products are not suitable for use in any medical products whose failure to perform may result in significant injury or death to the user. All products and materials are sold and services provided subject to Zarlink's conditions of sale which are available on request.

Purchase of Zarlink's I<sup>2</sup>C components conveys a licence under the Philips I<sup>2</sup>C Patent rights to use these components in and I<sup>2</sup>C System, provided that the system conforms to the I<sup>2</sup>C Standard Specification as defined by Philips.

Zarlink, ZL and the Zarlink Semiconductor logo are trademarks of Zarlink Semiconductor Inc.

Copyright Zarlink Semiconductor Inc. All Rights Reserved.

**TECHNICAL DOCUMENTATION - NOT FOR RESALE**

---