

## ASSP

# Serial Input PLL Frequency Synthesizer

## MB1511

### ■ DESCRIPTION

The Fujitsu MB1511 is a single chip serial input PLL frequency synthesizer designed for VHF tuner and cellular telephone applications.

It contains a 1.1 GHz dual modulus prescaler which enables pulse swallow function, and an analog switch to speed up lock up time.

It operates supply voltage of 3.0 V typ. and dissipates 7 mA typ. of current realized through the use of Fujitsu's unique U-ESBIC Bi-CMOS technology.

The MB1511 is housed in SSOP package, this enables high integration.

### ■ FEATURES

- Low power supply voltage:  $V_{CC} = 2.7$  to  $5.5$  V
- High operating frequency:  $f_{IN\ MAX} = 1.1$  GHz ( $V_{IN\ MIN} = -10$ dBm)
- Pulse swallow function: 64/65 or 128/129
- Low supply current:  $I_{CC} = 7$  mA typ.
- Serial input 18-bit programmable divider consisting of:
  - Binary 7-bit swallow counter: 0 to 127
  - Binary 11-bit programmable counter: 16 to 2047
- Serial input 15-bit programmable reference divider consisting of:
  - Binary 14-bit programmable reference counter: 8 to 16383
  - 1-bit switch counter (SW) sets divide ratio of prescaler

(Continued)

### ■ PACKAGE

20 pin, Plastic SSOP

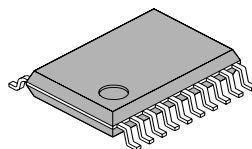

(FPT-20P-M03)

# MB1511

(Continued)

- On-chip analog switch achieves fast lock up time
- 2 types of phase detector output
  - On-chip charge pump (Bipolar type)
  - Output for external charge pump
- Wide operating temperature:  $-40^{\circ}\text{C}$  to  $+85^{\circ}\text{C}$
- 20-pin Plastic Shrink Small Outline Package (Suffix: -PFV)

## ■ PIN ASSIGNMENT

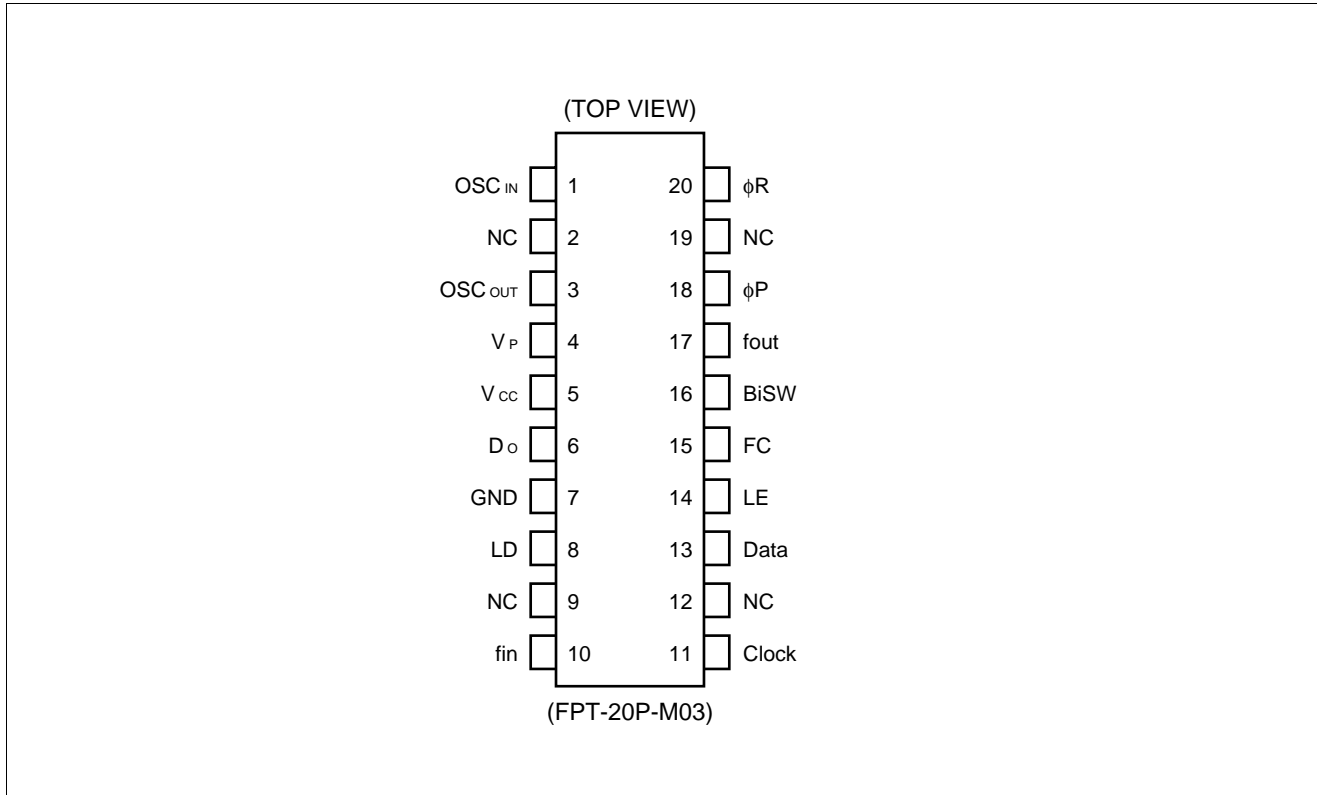

## ■ PIN DESCRIPTION

Pin No.	Pin Name	I/O	Functions
1	OSC <sub>IN</sub>	I	Oscillator input. Oscillator output. A crystal is placed between OSC <sub>IN</sub> and OSC <sub>OUT</sub> .
3	OSC <sub>OUT</sub>	O	
4	V <sub>P</sub>	—	Power supply input for charge pump and analog switch.
5	V <sub>CC</sub>	—	Power supply voltage input.
6	D <sub>O</sub>	O	Charge pump output. The characteristics of charge pump is reversed depending upon FC input.
7	GND	—	Ground.
8	LD	O	Phase comparator output. Normally this pin outputs high level. While the phase difference of f <sub>r</sub> and f <sub>p</sub> exists, this pin outputs low level.
10	f <sub>IN</sub>	I	Prescaler input. The connection with an external VCO should be AC connection.
11	Clock	I	Clock input for 19-bit shift register and 16-bit shift register. On rising edge of the clock shifts one bit of data into the shift registers.
13	Data	I	Binary serial data input. The last bit of the data is a control bit which specified destination of shift registers. When this bit is high level and LE is high level, the data stored in shift register is transferred to 15-bit latch. When this bit is low level and LE is high level, the data is transferred to 18-bit latch.
14	LE	I	Load enable input (with internal pull up resistor). When LE is high or open, the data stored in shift register is transferred into latch depending upon the control bit. At the time, internal charge pump output is connected to BISW pin because internal analog switch becomes ON state.
15	FC	I	Phase select input of phase comparator (with internal pull up resistor). When FC is low level, the characteristics of charge pump, phase comparator is reversed. FC input signal controls f <sub>out</sub> pin (test pin) output level, f <sub>r</sub> or f <sub>p</sub> .
16	BISW	O	Analog switch output. Usually BISW pin is set high-impedance state. When internal analog switch is ON (LE pin is high level), this pin outputs internal charge pump output.
17	f <sub>OUT</sub>	O	Monitor pin of phase comparator input. f <sub>out</sub> pin outputs either programmable reference divider output (f <sub>r</sub> ) or programmable divider output (f <sub>p</sub> ) depending upon FC pin input level. FC = H: It is the same as f <sub>r</sub> output level. FC = L: It is the same as f <sub>p</sub> output level.
18	φP	O	Output for external charge pump. The characteristics are reversed according to FC input. φP pin is N-channel open drain output.
20	φR	O	
2, 9 12, 19	NC	—	No connection.

# MB1511

## ■ BLOCK DIAGRAM

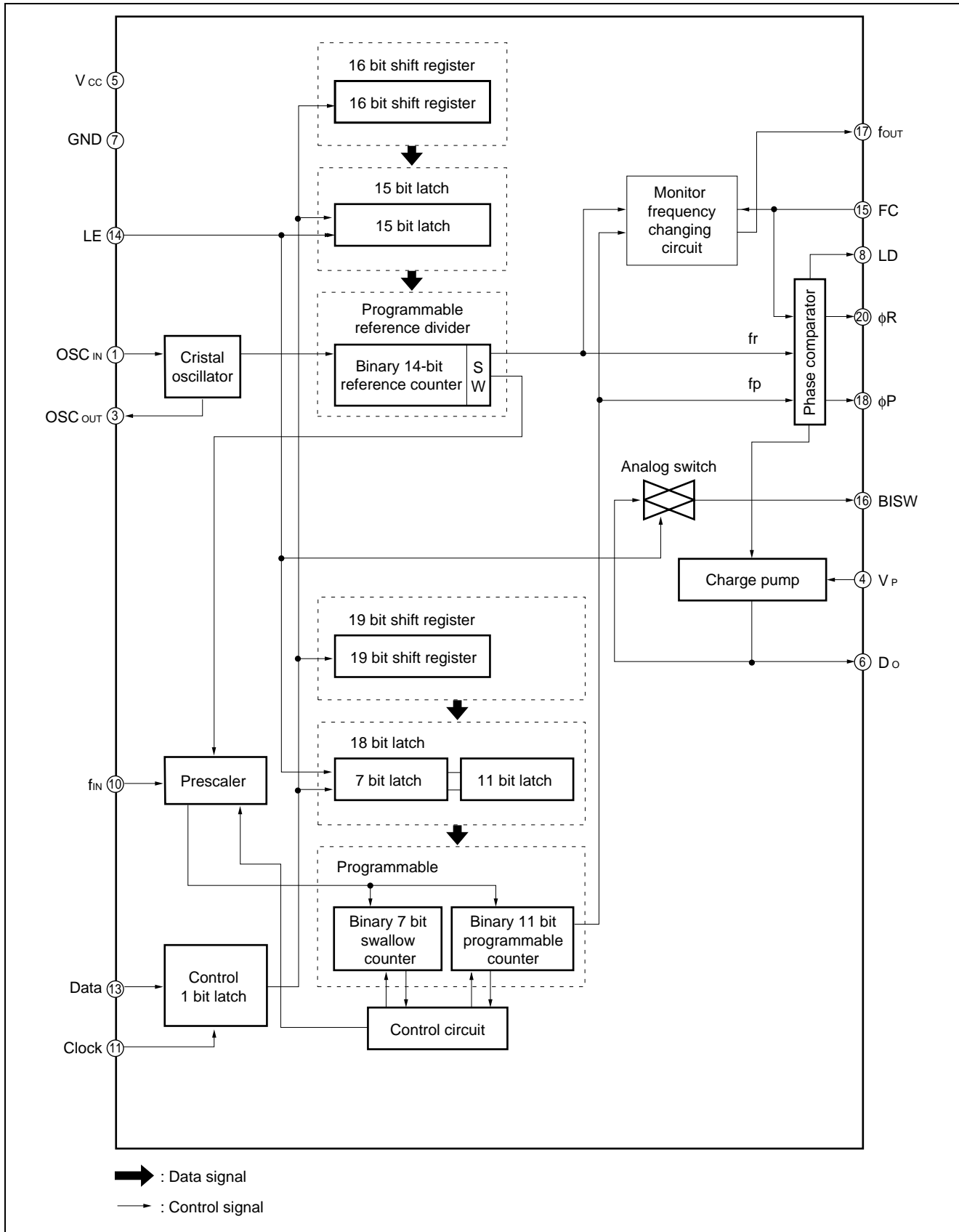

## ■ FUNCTIONAL DESCRIPTIONS

### 1. Pulse Swallow Function

The divide ratio is set using the following equation.

$$f_{vco} = [(M \times N) + A] \times f_{osc} \div R$$

$f_{vco}$  : Output frequency of external voltage controlled oscillator (VCO)

$M$  : Preset modulus of external dual modulus prescaler (64 or 128)

$N$  : Preset divide ratio of binary 11-bit programmable counter (16 to 2047)

$A$  : Preset divide ratio of binary 7-bit swallow counter ( $0 \leq A \leq 127$ ,  $A < N$ )

$f_{osc}$  : Output frequency of the external reference frequency oscillator

$R$  : Preset divide ratio of binary 14-bit programmable reference counter (8 to 16383)

### 2. Serial Data Input

Serial data input is achieved by three inputs, such as Data pin, Clock pin and LE pin. Serial data input controls 15-bit programmable reference divider and 18-bit programmable divider, respectively.

Binary serial data is input to Data pin.

On rising edge of clock shifts one bit of serial data into the internal shift registers and when load enable pin is high level or open, stored data is transferred into latch depending upon the control bit.

Control data "H" data is transferred into 15-bit latch.

Control data "L" data is transferred into 18-bit latch.

## (1) Programmable Reference Divider

Programmable reference divider consists of 16-bit shift register, 15-bit latch and 14-bit reference counter. Serial 16-bit data format is shown below.

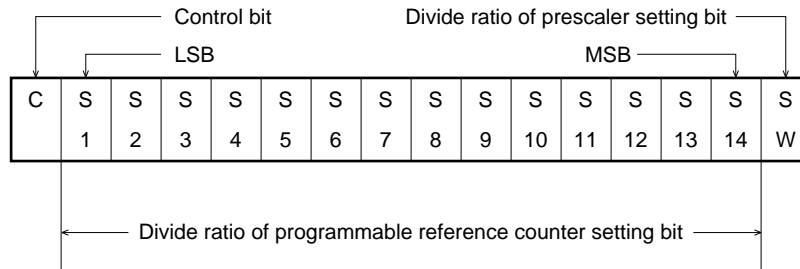

### • 14-BIT PROGRAMMABLE REFERENCE COUNTER DIVIDE RATIO

Divide Ratio	S14	S13	S12	S11	S10	S9	S8	S7	S6	S5	S4	S3	S2	S1
8	0	0	0	0	0	0	0	0	0	0	1	0	0	0
9	0	0	0	0	0	0	0	0	0	0	1	0	0	1
⋮	⋮	⋮	⋮	⋮	⋮	⋮	⋮	⋮	⋮	⋮	⋮	⋮	⋮	⋮
16383	1	1	1	1	1	1	1	1	1	1	1	1	1	1

NOTES: Divide ratio less than 8 is prohibited.

Divide ratio: 8 to 16383

SW: This bit selects divide ratio of prescaler.

SW = H: 64/65

SW = L: 128/129

S1 to S14: These bits select divide ratio of programmable reference divider.

C: Control bit (sets as high level).

Data is input from MSB side.

## (2) Programmable Divider

Programmable divider consists of 19-bit shift register, 18-bit latch, 7-bit swallow counter and 11-bit programmable counter. Serial 19-bit data format is shown following page.

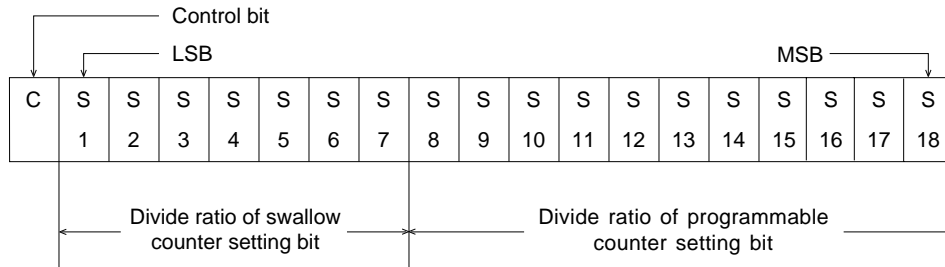

### • 7-bit Swallow Counter Divide Ratio

Divide Ratio	S 7	S 6	S 5	S 4	S 3	S 2	S 1
A	7	6	5	4	3	2	1
0	0	0	0	0	0	0	0
1	0	0	0	0	0	0	1
⋮	⋮	⋮	⋮	⋮	⋮	⋮	⋮
127	1	1	1	1	1	1	1

Note: Divide ratio: 0 to 127

### • 11-bit Programmable Counter Divide Ratio

Divide Ratio	S 18	S 17	S 16	S 15	S 14	S 13	S 12	S 11	S 10	S 9	S 8
N	18	17	16	15	14	13	12	11	10	9	8
16	0	0	0	0	0	0	1	0	0	0	1
17	0	0	0	0	0	0	1	0	0	0	1
⋮	⋮	⋮	⋮	⋮	⋮	⋮	⋮	⋮	⋮	⋮	⋮
2047	1	1	1	1	1	1	1	1	1	1	1

Notes: Divide ratio less than 16 is prohibited.  
 Divide ratio: 16 to 2047  
 S1 to S7: Swallow counter divide ratio setting bit. (0 to 127)  
 S8 to S18: Programmable counter divide ratio setting bit. (16 to 2047)  
 C: Control bit (sets as low level).  
 Data is input from MSB side.

## 3. Serial Data Input Timing

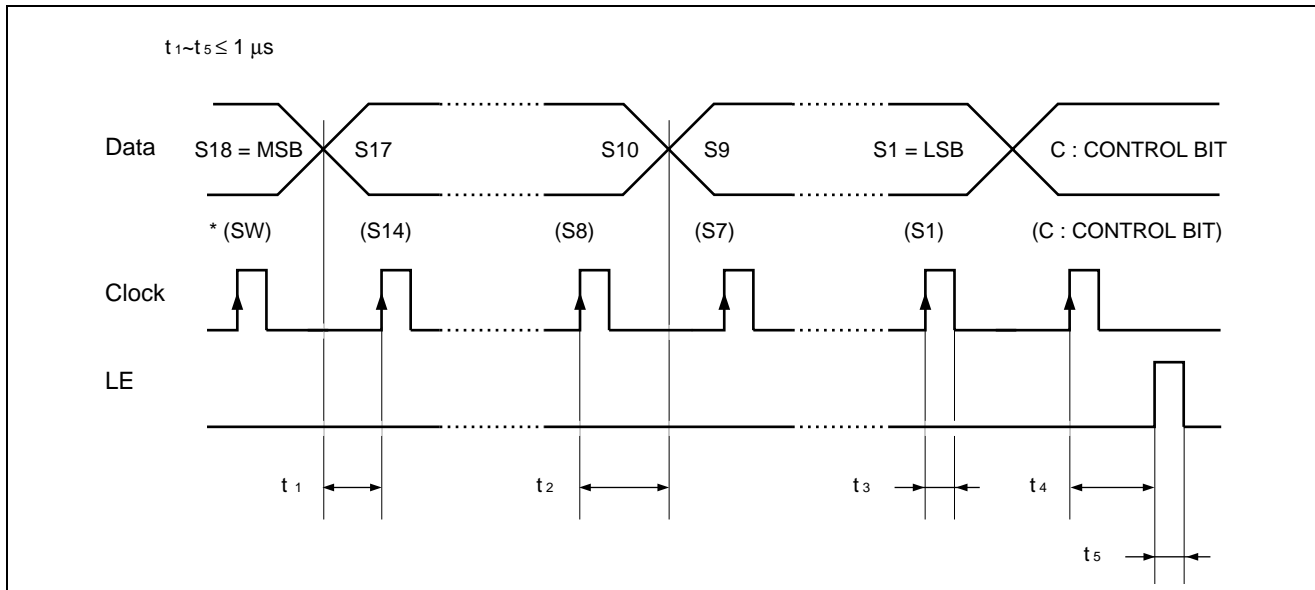

Notes: Paranthesis data is used for setting divide ratio of programmable reference divider.  
 On rising edge of clock shifts one bit of data in the shift register.

## 4. Phase Characteristics

FC pin is provided to change phase characteristics of phase comparator. Characteristics of internal charge pump output level ( $D_o$ ), phase comparator output level ( $\phi_R$ ,  $\phi_P$ ) are reversed depending upon FC pin input level. Also, monitor pin ( $f_{OUT}$ ) output level of phase comparator is controlled by FC pin input level. The relation between outputs ( $D_o$ ,  $\phi_R$ ,  $\phi_P$ ) and FC input level are shown below.

	FC : "H" or open				FC : "L"			
	$D_o$	$\phi_R$	$\phi_P$	$f_{OUT}$	$D_o$	$\phi_R$	$\phi_P$	$f_{OUT}$
$f_r > f_p$	H	L	L	(fr)	L	H	Z	(fp)
$f_r = f_p$	Z	L	Z	(fr)	Z	L	Z	(fp)
$f_r < f_p$	L	H	Z	(fr)	H	L	L	(fp)

Note: Z = (High impedance)

Depending upon VCO characteristics, FC pin should be set accordingly:

- When VCO characteristics are like (1), FC should be set High or open circuit; When VCO characteristics are like (2), FC should be set Low.

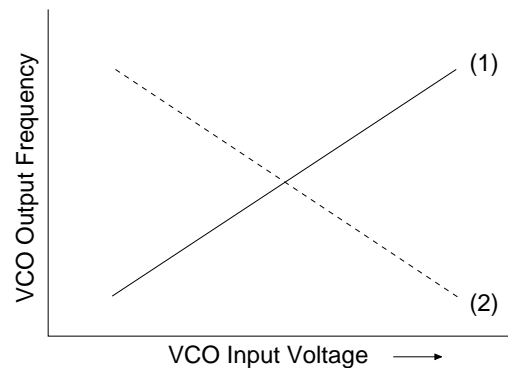

Phase comparator output waveforms are shown below.

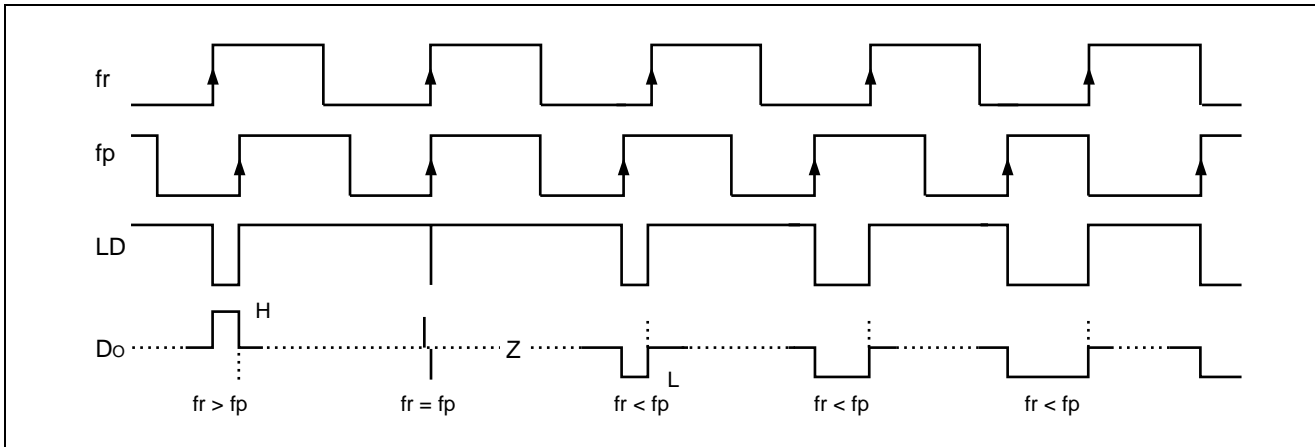

Notes: Phase difference detection range:  $-2\pi$  to  $+2\pi$

Spike appearance depends on charge pump characteristics. Also, the spike is output in order to diminish dead band. When  $fr > fp$  or  $fr < fp$ , spike might not appear depending upon charge pump characteristics.

## 5. Analog Switch

ON/OFF of analog switch is controlled by LE input signal. When the analog switch is ON, internal charge pump output ( $D_o$ ) is connected to BISW pin. When the analog switch is OFF, BISW pin is set to high-impedance state.

LE	Analog Switch
H (Changing the divide ratio of internal prescaler)	ON
L (Normal operation mode)	OFF

When an analog switch is inserted between LP1 and LP2, faster lock up times is achieved to reduce LPF time constant during PLL channel switching.

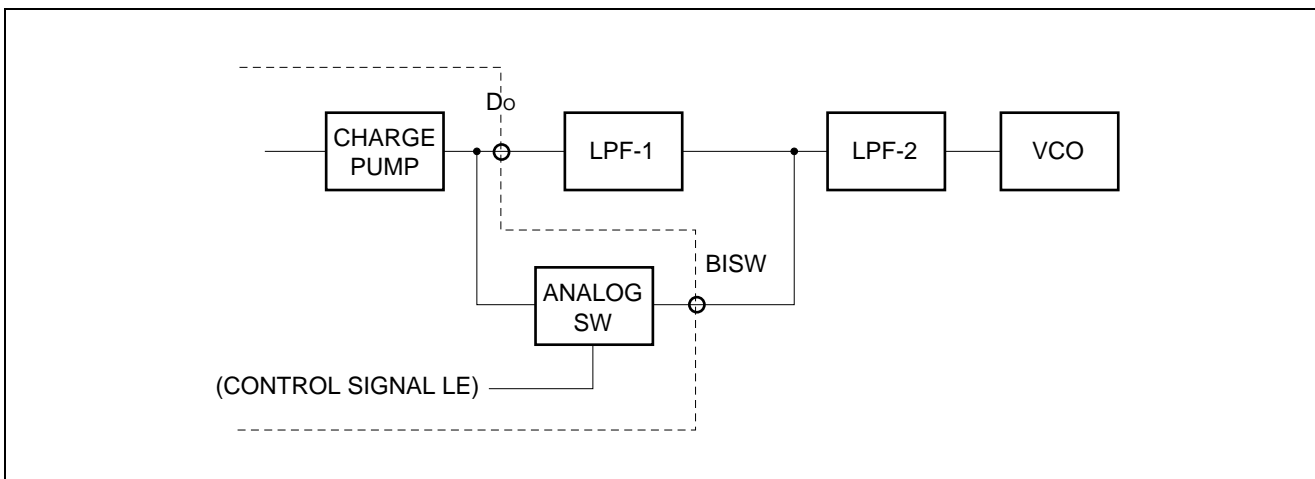

# MB1511

## ■ ABSOLUTE MAXIMUM RATINGS (See WARNING)

Parameter	Symbol	Rating	Unit
Power supply voltage	$V_{CC}$	-0.5 to 7.0	V
	$V_P$	$V_{CC}$ to 10.0	V
Output voltage	$V_{OUT}$	-0.5 to $V_{CC} + 0.5$	V
Open-drain voltage	$V_{OOP}$	-0.5 to 8.0	V
Output current	$I_{OUT}$	$\pm 10$	mA
Storage temperature	$T_{STG}$	-55 to +125	°C

**WARNING:** Permanent device damage may occur if the above **Absolute Maximum Ratings** are exceeded. Functional operation should be restricted to the conditions as detailed in the operational sections of this data sheet. Exposure to absolute maximum rating conditions for extended periods may affect device reliability.

## ■ RECOMMENDED OPERATING CONDITIONS

Parameter	Symbol	Value			Unit
		Min.	Typ.	Max.	
Power supply voltage	$V_{CC}$	2.7	3.0	5.5	V
	$V_P$	$V_{CC}$	—	8.0	V
Input voltage	$V_{IN}$	GND	—	$V_{CC}$	V
Operating temperature	$T_a$	-40	—	+85	°C

## HANDLING PRECAUTIONS

- This device should be transported and stored in anti-static containers.
- This is static-sensitive device; take proper anti-ESD precautions. Ensure that personnel and equipment are properly grounded. Cover workbenches with grounded conductive mats.
- Always turn the power supply off before inserting or removing the device from its socket.
- Protect leads with a conductive sheet when handling or transporting PC boards with devices.

## ■ ELECTRICAL CHARACTERISTICS

( $V_{CC} = 2.7\text{ V to }5.5\text{ V}$ ,  $T_a = -40^\circ\text{C to }+85^\circ\text{C}$ )

Parameter	Symbol	Values			Unit	
		Min.	Typ.	Max.		
Power supply current*1	$I_{CC}$	—	7.0	—	mA	
Operating frequency	$f_{IN}^{*2}$	10	—	1100	MHz	
	$OSC_{IN}$	—	12	20	MHz	
Input sensitivity	$f_{in-1}^{*3}$	-4	—	6	dBm	
	$f_{in-2}^{*4}$	-10	—	6	dBm	
	$OSC_{IN}$	0.5	—	—	V <sub>p-p</sub>	
High-level input voltage	Except $f_{in}$ and $OSC_{IN}$	$V_{IH}$	$V_{CC} \times 0.7$	—	V	
Low-level input voltage		$V_{IL}$	—	$V_{CC} \times 0.3$	V	
High-level input current	Data clock	$I_{IH}$	—	1.0	μA	
Low-level input current		$I_{IL}$	—	-1.0	μA	
Input current	$OSC_{IN}$	$I_{OSC}$	—	±50	μA	
	LE, FC	$I_{LE}$	—	-60	μA	
High-level output current	Except $D_o$ and $OSC_{OUT}$	$V_{OH}^{*5}$	2.2	—	V	
Low-level output current		$V_{OL}$	—	—	0.4	V
N-channel open drain cutoff current	$D_o, \phi P^{*6}$	$I_{OFF}$	—	—	1.1	μA
Output current	Except $D_o$ and $OSC_{OUT}$	$I_{OH}$	-1.0	—	—	mA
		$I_{OL}$	1.0	—	—	mA
Analog switch on resistance	$R_{ON}$	—	50	—	Ω	

Notes: \*1  $f_{in} = 1.1\text{ GHz}$ ,  $OSC_{IN} = 12\text{ MHz}$ ,  $V_{CC} = 3\text{V}$ . Inputs are grounded and outputs are open.

\*2 AC coupling. Minimum operating frequency is measured when a capacitor 1000pF.

\*3  $V_{CC} = 4.0\text{ to }5.5\text{V}$ ,  $50\ \Omega$

\*4  $V_{CC} = 2.7\text{ to }4.0\text{V}$ ,  $50\ \Omega$

\*5  $V_{CC} = 3\text{V}$

\*6  $V_P = V_{CC}\text{ to }8\text{V}$ ,  $V_{OOP} = \text{GND to }8\text{V}$

## MEASUREMENT CIRCUIT

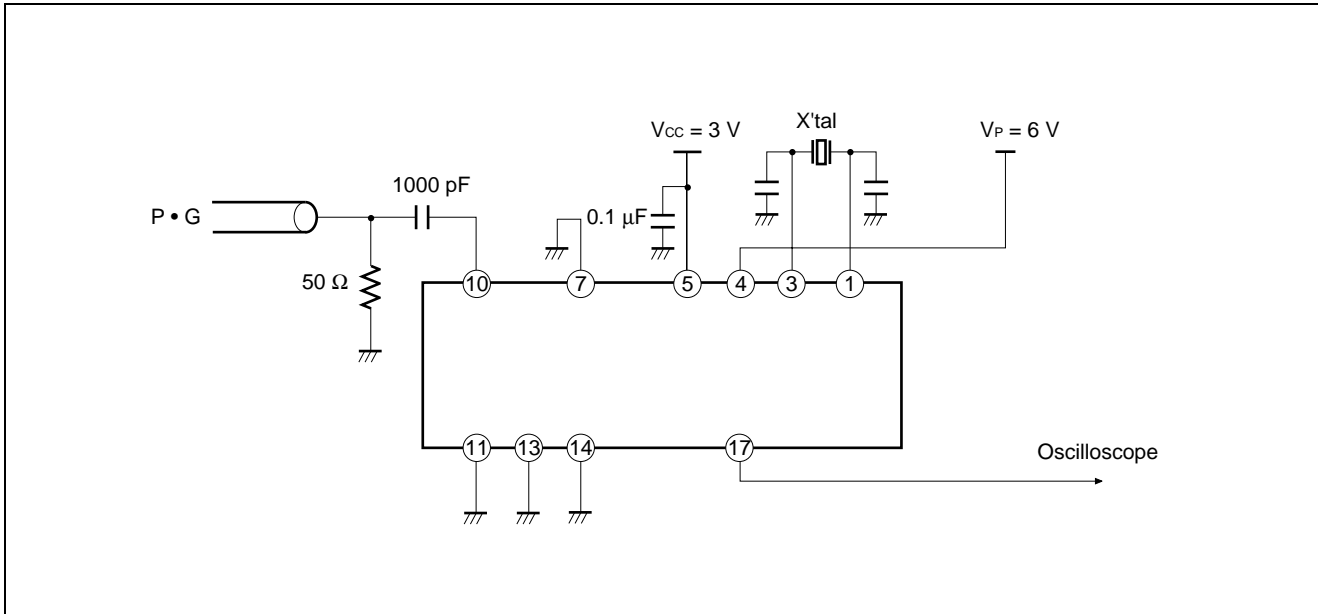

## ■ TYPICAL APPLICATION EXAMPLE

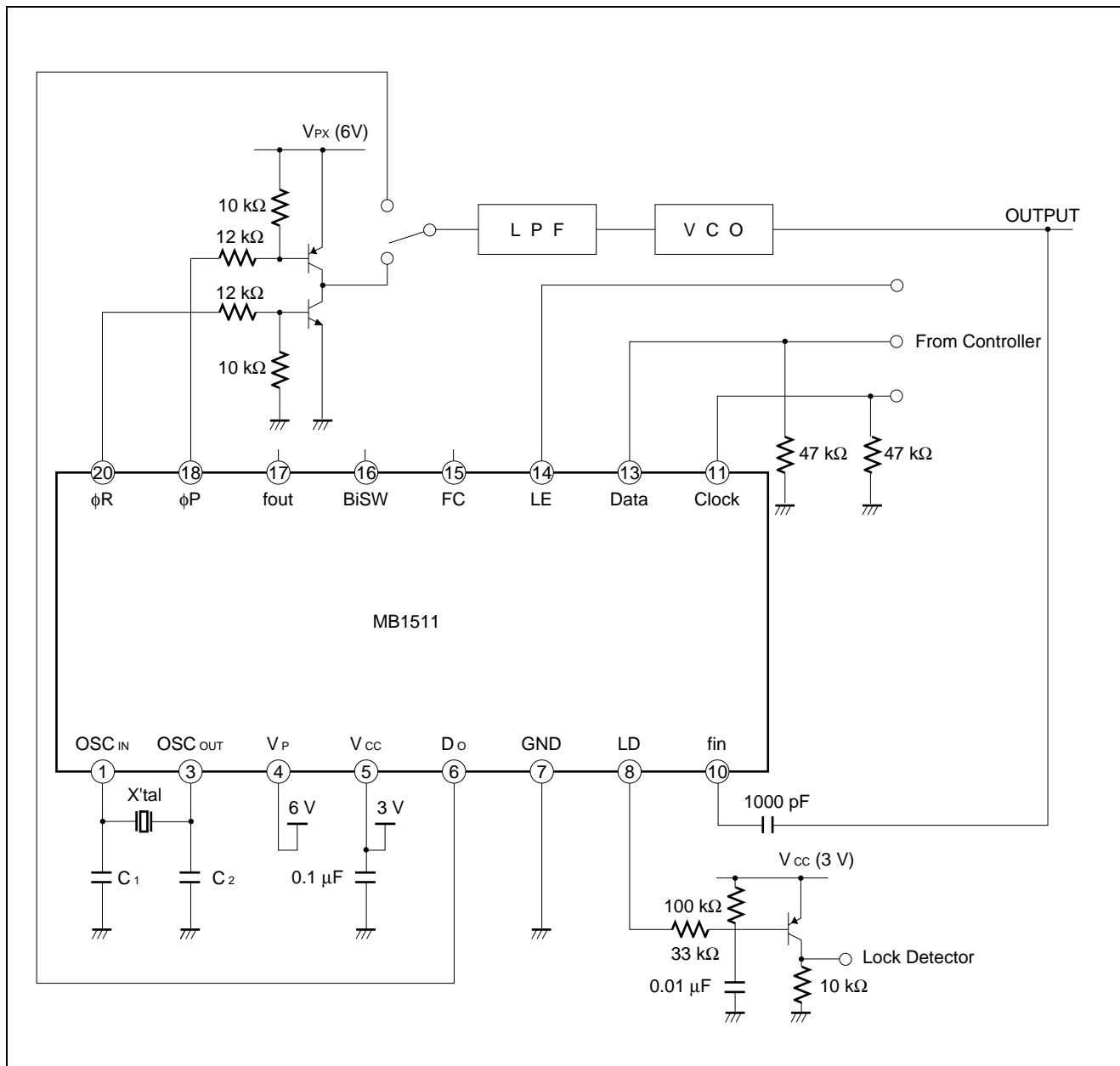

$V_{PX}, V_P$  : 8V max.

$C_1, C_2$  : Depends on crystal oscillator

LE, FC : With internal pull up resistor

$\phi P$  : Open drain output

# MB1511

## ■ PACKAGE DIMENSION

20 pin, Plastic SSOP  
(FPT-20P-M03)

\*: This dimension does not include resin protrusion.

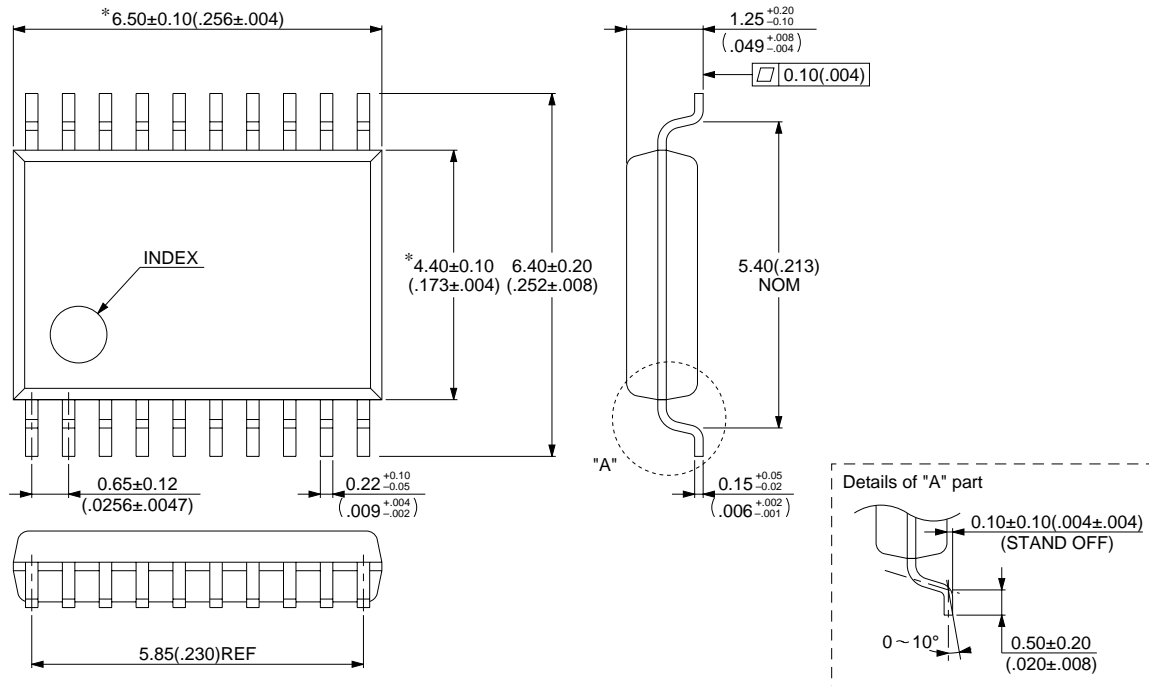

© 1994 FUJITSU LIMITED F20012S-2C-4

Dimensions in mm (inches).

## FUJITSU LIMITED

*For further information please contact:*

### **Japan**

FUJITSU LIMITED  
Corporate Global Business Support Division  
Electronic Devices  
KAWASAKI PLANT, 4-1-1, Kamikodanaka  
Nakahara-ku, Kawasaki-shi  
Kanagawa 211-8588, Japan  
Tel: (044) 754-3763  
Fax: (044) 754-3329

<http://www.fujitsu.co.jp/>

### **North and South America**

FUJITSU MICROELECTRONICS, INC.  
Semiconductor Division  
3545 North First Street  
San Jose, CA 95134-1804, USA  
Tel: (408) 922-9000  
Fax: (408) 922-9179

Customer Response Center  
*Mon. - Fri.: 7 am - 5 pm (PST)*  
Tel: (800) 866-8608  
Fax: (408) 922-9179

<http://www.fujitsumicro.com/>

### **Europe**

FUJITSU MIKROELEKTRONIK GmbH  
Am Siebenstein 6-10  
D-63303 Dreieich-Buchsschlag  
Germany  
Tel: (06103) 690-0  
Fax: (06103) 690-122

<http://www.fujitsu-edc.com/>

### **Asia Pacific**

FUJITSU MICROELECTRONICS ASIA PTE LTD  
#05-08, 151 Lorong Chuan  
New Tech Park  
Singapore 556741  
Tel: (65) 281-0770  
Fax: (65) 281-0220

<http://www.fmap.com.sg/>

F9803

© FUJITSU LIMITED Printed in Japan

All Rights Reserved.

The contents of this document are subject to change without notice. Customers are advised to consult with FUJITSU sales representatives before ordering.

The information and circuit diagrams in this document presented as examples of semiconductor device applications, and are not intended to be incorporated in devices for actual use. Also, FUJITSU is unable to assume responsibility for infringement of any patent rights or other rights of third parties arising from the use of this information or circuit diagrams.

FUJITSU semiconductor devices are intended for use in standard applications (computers, office automation and other office equipment, industrial, communications, and measurement equipment, personal or household devices, etc.).

#### **CAUTION:**

Customers considering the use of our products in special applications where failure or abnormal operation may directly affect human lives or cause physical injury or property damage, or where extremely high levels of reliability are demanded (such as aerospace systems, atomic energy controls, sea floor repeaters, vehicle operating controls, medical devices for life support, etc.) are requested to consult with FUJITSU sales representatives before such use. The company will not be responsible for damages arising from such use without prior approval.

Any semiconductor devices have inherently a certain rate of failure. You must protect against injury, damage or loss from such failures by incorporating safety design measures into your facility and equipment such as redundancy, fire protection, and prevention of over-current levels and other abnormal operating conditions.

If any products described in this document represent goods or technologies subject to certain restrictions on export under the Foreign Exchange and Foreign Trade Control Law of Japan, the prior authorization by Japanese government should be required for export of those products from Japan.