

ASSP

QUAD OPERATIONAL AMPLIFIER

MB3615

QUAD OPERATIONAL AMPLIFIER

OPERATES FROM A SINGLE OR DUAL POWER SUPPLY

The Fujitsu MB3615 is a Quad operational amplifier having a phase compensatory circuit and operates from a single power supply or dual power supplies.

The device has equivalent electrical characteristics of current industrial standard operational amplifier and requires low power supply current.

MB3615 can be mounted in high density because it integrates 4 circuits on a chip in 14-pin package. It is taking the countermeasure for cross-over distortion, so can be used for amplifying AC.

The MB3615 is pin compatible with Motorola MC3303.

- No phase compensation required
- Wide power supply voltage
 - Single power supply: +3 to +30 V
 - Dual power supplies: ± 1.5 to ± 15 V
- Wide input common mode range: 0 to (VCC -1.5) V
- Low power supply current: 2 mA typ.
- Low Cross-over distortion

ABSOLUTE MAXIMUM RATINGS (see NOTE)

Ta=25°C

Rating	Symbol	Value	Unit
Power Supply Voltage *	V _{CC}	36	V
Differential Input Voltage *	V _{ID}	36	V
Input Common Mode Voltage *	V _I	-0.3 to +36	V
Power Dissipation	P _D	570	mW
Operating Temperature	T _{OP}	-20 to +75	°C
Storage Temperature	T _{STG}	-55 to +125	°C

NOTE: * Single Power Supply.

Permanent device damage may occur if the above **Absolute Maximum Ratings** are exceeded. Functional operation should be restricted to the conditions as detailed in the operational sections of this data sheet. Exposure to absolute maximum rating conditions for extended periods may affect device reliability.

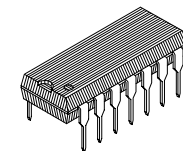

PLASTIC PACKAGE
DIP-14P-M02

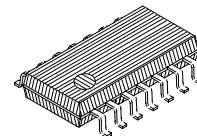

PLASTIC PACKAGE
FPT-14P-M04

PIN ASSIGNMENT (TOP VIEW)

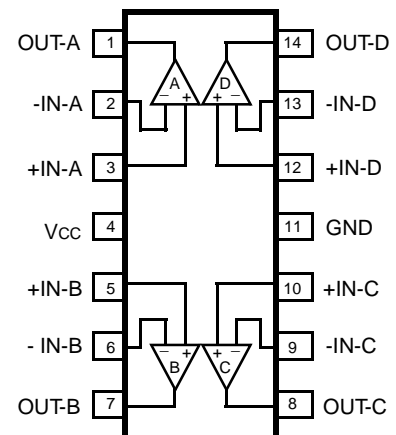

This device contains circuitry to protect the inputs against damage due to high static voltages or electric fields. However, it is advised that normal precautions be taken to avoid application of any voltage higher than maximum rated voltages to this high impedance circuit.

Fig. 1 — MB3615 EQUIVALENT CIRCUIT

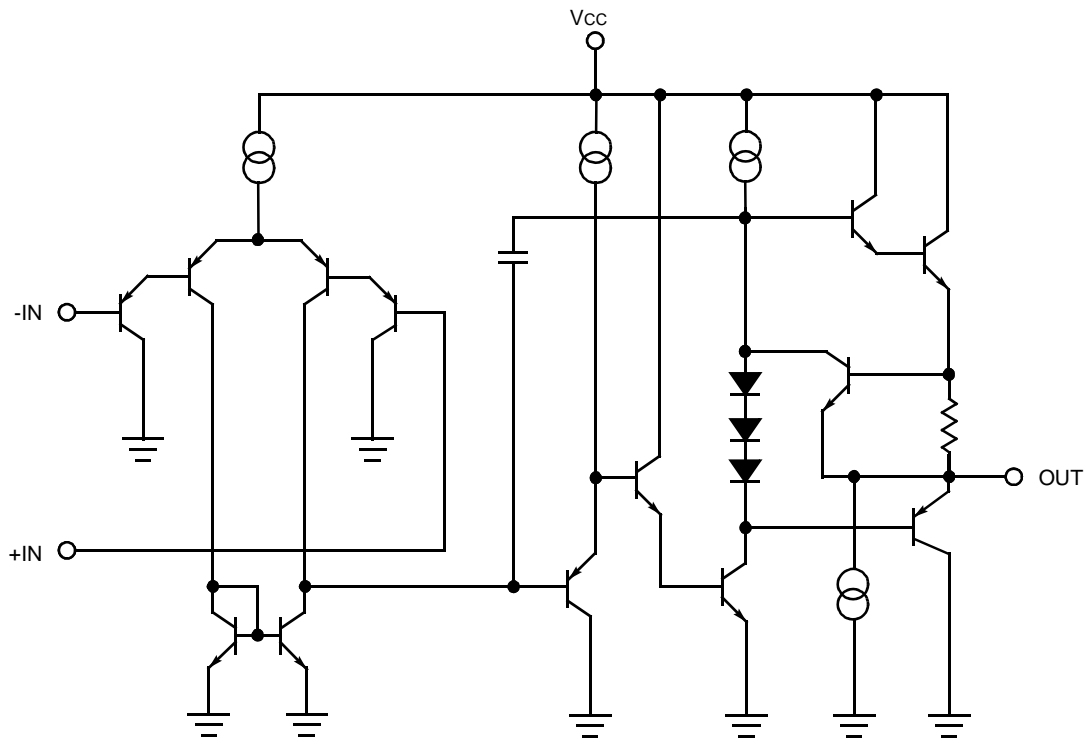

■ ELECTRICAL CHARACTERISTICS

(VCC = +15V, VEE = -15V, Ta = 25°C)

Parameter	Symbol	Condition	Value			Unit
			Min	Typ	Max	
Input Offset Voltage	V _{IO}	-	-	2	7	mV
Input Offset Current	I _{IO}	-	-	5	50	nA
Input Bias Current	I _I *	-	-	45	250	nA
Power Supply Current	I _{CC}	R _L = ∞	-	2.0	4.0	mA
Input Common Mode Voltage	V _{CM}	-	V _{EE}	-	V _{CC} -1.5	V
Voltage Gain	A _v	R _L ≥ 2kΩ	20	100	-	V/mV
Output Voltage Range	V _{OM}	R _L ≥ 2kΩ	±10	±12	-	V
		R _L = 2kΩ	±12	±13	-	V
Output Current	I _{SOUECE}	-	10	40	-	mA
	I _{SINK}	-	10	20	-	mA
Common Mode Rejection Ratio	CMRR	-	70	85	-	dB
Power Supply Voltage Rejection Ratio	SVRR	-	65	100	-	dB
Channel Separation	CS	-	-	120	-	dB

NOTE:

* A direction of the input bias current flows from IC because first input transistor consists of PNP.

TYPICAL CHARACTERISTICS CURVES

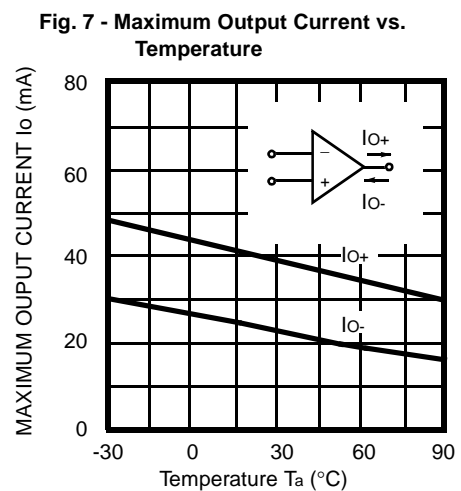
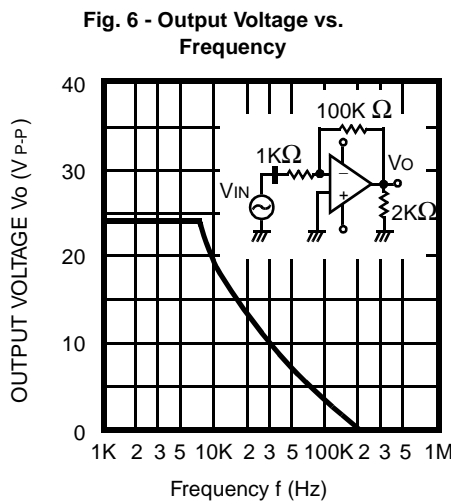
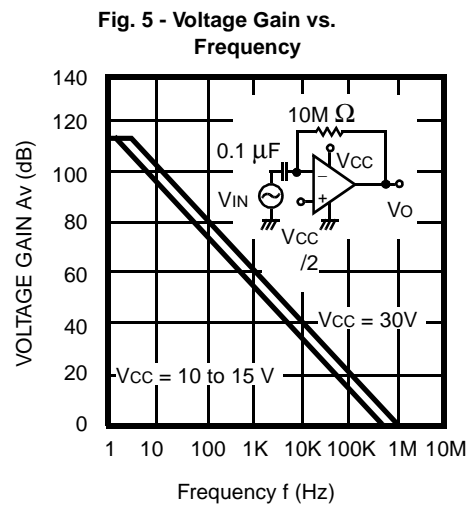
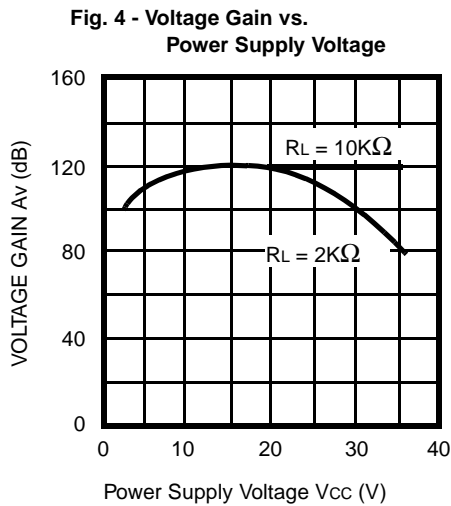
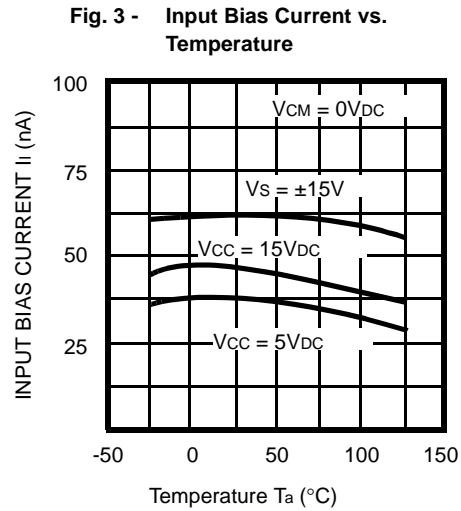
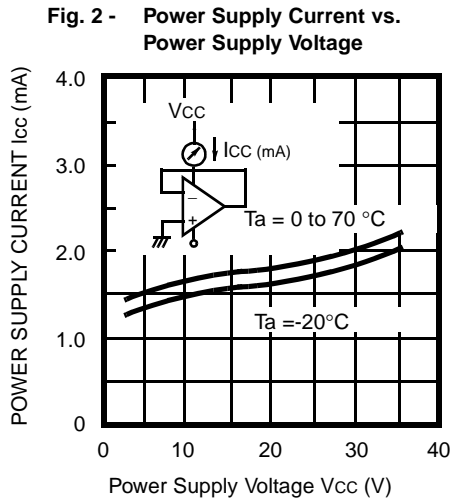

■ PACKAGE DIMENSIONS

14 pin, Plastic DIP
(DIP-14P-M02)

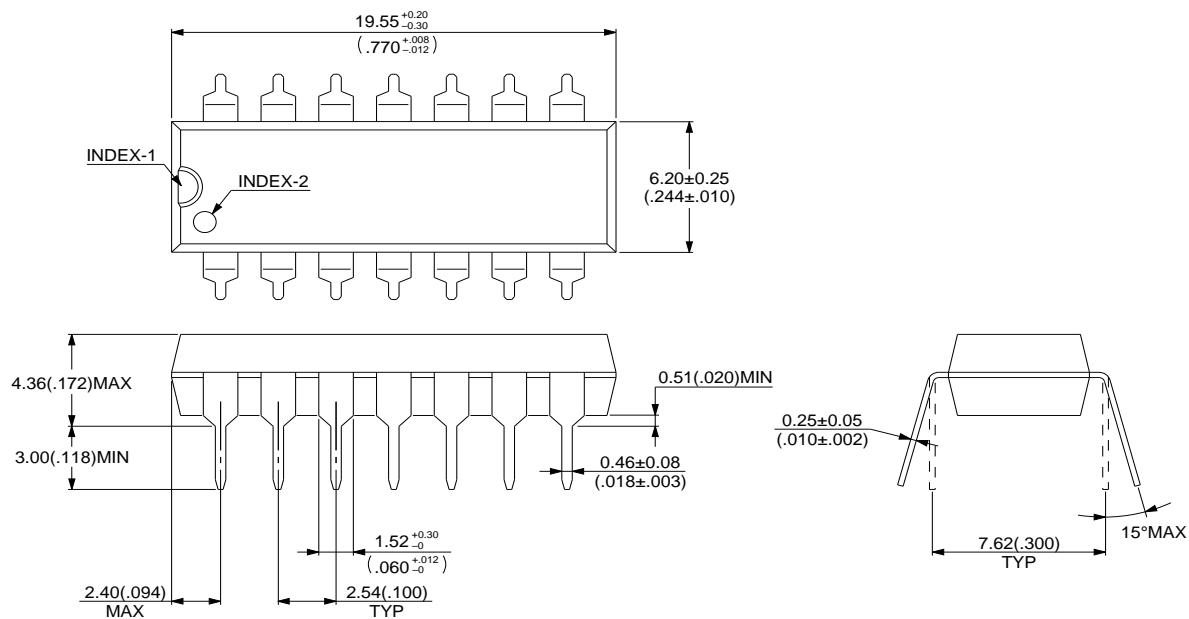

© 1994 FUJITSU LIMITED D14010S-4C-3

Dimensions in mm(inches).

■ PACKAGE DIMENSIONS (Continued)

14 pin, Plastic SOP
(FPT-14P-M04)

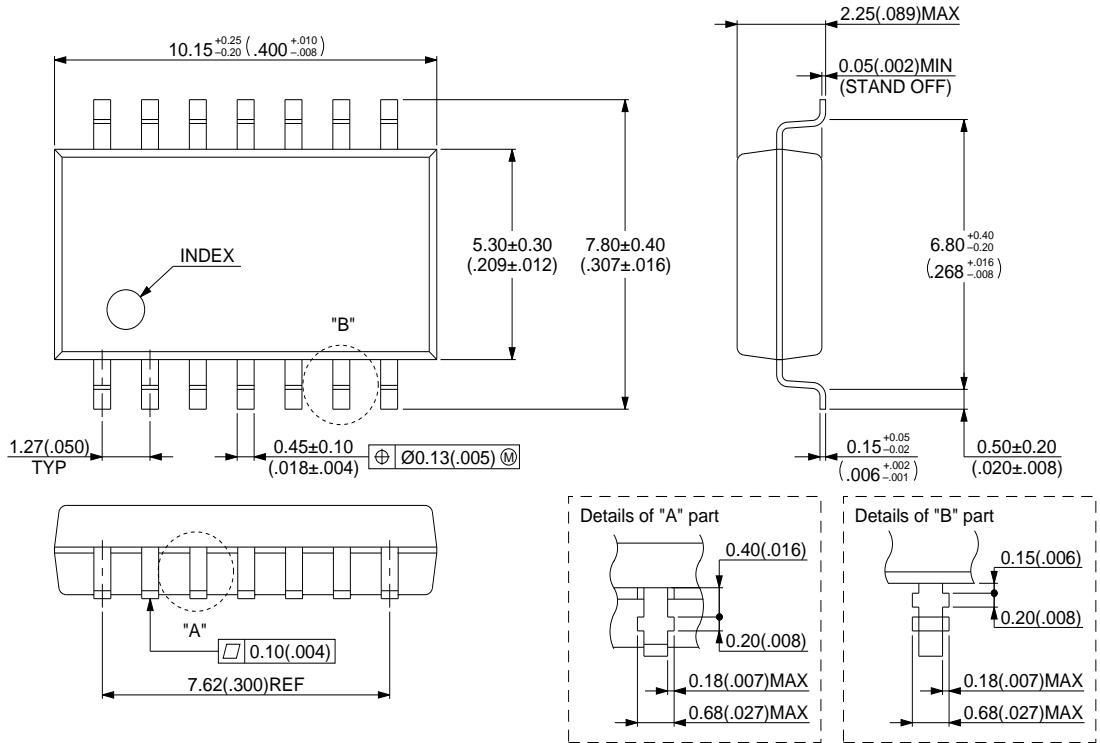

© 1994 FUJITSU LIMITED F14010S-2C-4

Dimensions in mm(inches).

FUJITSU LIMITED

For further information please contact:

Japan

FUJITSU LIMITED
Corporate Global Business Support Division
Electronic Devices
KAWASAKI PLANT, 4-1-1, Kamikodanaka
Nakahara-ku, Kawasaki-shi
Kanagawa 211-88, Japan
Tel: (044) 754-3763
Fax: (044) 754-3329

North and South America

FUJITSU MICROELECTRONICS, INC.
Semiconductor Division
3545 North First Street
San Jose, CA 95134-1804, U.S.A.
Tel: (408) 922-9000
Fax: (408) 432-9044/9045

Europe

FUJITSU MIKROELEKTRONIK GmbH
Am Siebenstein 6-10
63303 Dreieich-Buchsschlag
Germany
Tel: (06103) 690-0
Fax: (06103) 690-122

Asia Pacific

FUJITSU MICROELECTRONICS ASIA PTE. LIMITED
#05-08, 151 Lorong Chuan
New Tech Park
Singapore 556741
Tel: (65) 281-0770
Fax: (65) 281-0220

All Rights Reserved.

The contents of this document are subject to change without notice. Customers are advised to consult with FUJITSU sales representatives before ordering.

The information and circuit diagrams in this document presented as examples of semiconductor device applications, and are not intended to be incorporated in devices for actual use. Also, FUJITSU is unable to assume responsibility for infringement of any patent rights or other rights of third parties arising from the use of this information or circuit diagrams.

FUJITSU semiconductor devices are intended for use in standard applications (computers, office automation and other office equipment, industrial, communications, and measurement equipment, personal or household devices, etc.).

CAUTION:

Customers considering the use of our products in special applications where failure or abnormal operation may directly affect human lives or cause physical injury or property damage, or where extremely high levels of reliability are demanded (such as aerospace systems, atomic energy controls, sea floor repeaters, vehicle operating controls, medical devices for life support, etc.) are requested to consult with FUJITSU sales representatives before such use. The company will not be responsible for damages arising from such use without prior approval.

Any semiconductor devices have inherently a certain rate of failure. You must protect against injury, damage or loss from such failures by incorporating safety design measures into your facility and equipment such as redundancy, fire protection, and prevention of over-current levels and other abnormal operating conditions.

If any products described in this document represent goods or technologies subject to certain restrictions on export under the Foreign Exchange and Foreign Trade Control Law of Japan, the prior authorization by Japanese government should be required for export of those products from Japan.

F9703

© FUJITSU LIMITED Printed in Japan