

ASSP

Pulse-Width-Modulation Control Circuit

MB3759

PULSE-WIDTH-MODULATION CONTROL CIRCUIT PUSH-PULL/SINGLE-ENDED OUTPUT MODE

The Fujitsu MB3759 is complete pulse-width modulation control system on a single monolithic chip. The MB3759 consists of an internal 5.00V reference, two or-connected amplifiers, externally timed (or synchronized) oscillator and control ramp generator. The MB3759 provides for either push-pull or single-ended mode of operation with external control of dead-band.

The two NPN output transistors have uncommitted emitters and collectors that can be used to either sink or source up to 200mA each.

- Complete pulse-width-modulation system with power control circuit
- Either push-pull or single-ended mode of operation
- Internal circuitry prohibits double pulse at either output
- On-chip voltage reference (5V)
- Uncommitted output drivers
- Master or slave oscillator control
- Dual error amplifiers
- Under voltage lockout function
- Dead time adjustable
- Package: 16-pin Plastic DIP Package (Suffix -P)
16-pin Ceramic DIP Package (Suffix -Z)
16-pin Plastic FPT Package (Suffix -PF)

ABSOLUTE MAXIMUM RATINGS (see NOTE)

Parameter	Symbol	Rating	Unit
Power Supply Voltage	V _{CC}	41	V
Collector Output Voltage	V _{CE}	41	V
Collector Output Current	I _{CE}	250	mA
Amplifier Input Voltage	V _{IN}	V _{CC} +0.3	V
Power Dissipation	Plastic DIP	P _D	1000 (TA ≤ 25°C)
	Ceramic DIP		800 (TA ≤ 60°C)
	Plastic FPT		620 (TA ≤ 25°C)*
Operating Temperature	DIP	TA	-20 to 85
	FPT		-20 to 75
Storage Temperature	TSTG	-55 to 125	°C

* PFT package is mounted on the epoxy board. (4cm x 4cm x 0.15cm)

NOTE: Permanent device damage may occur if the above **Absolute Maximum Ratings** are exceeded. Functional operation should be restricted to the conditions as detailed in the operational sections of this data sheet. Exposure to absolute maximum rating conditions for extended periods may affect device reliability.

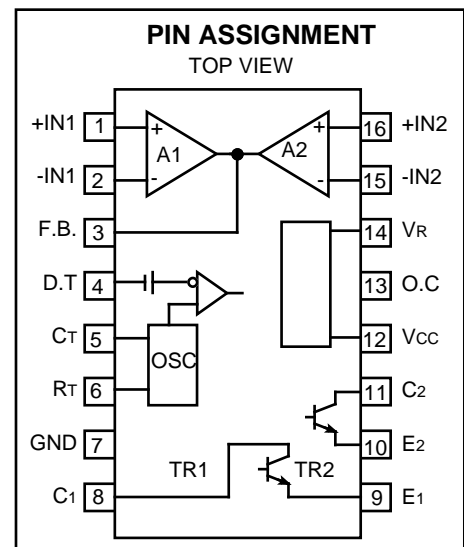
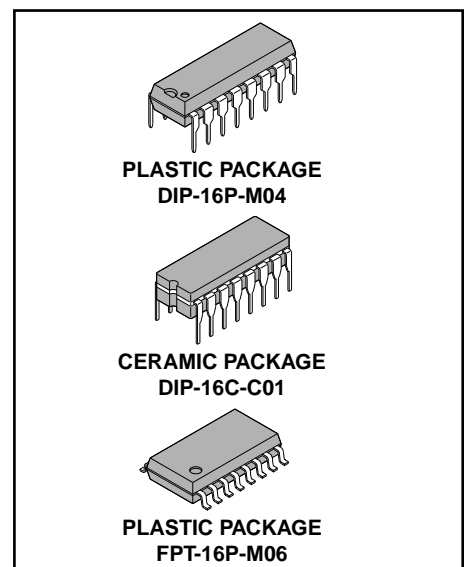

This device contains circuitry to protect the inputs against damage due to high static voltages or electric fields. However, it is advised that normal precautions be taken to avoid application of any voltage higher than maximum rated voltages to this high impedance circuit.

Fig. 1 - MB3759 BLOCK DIAGRAM

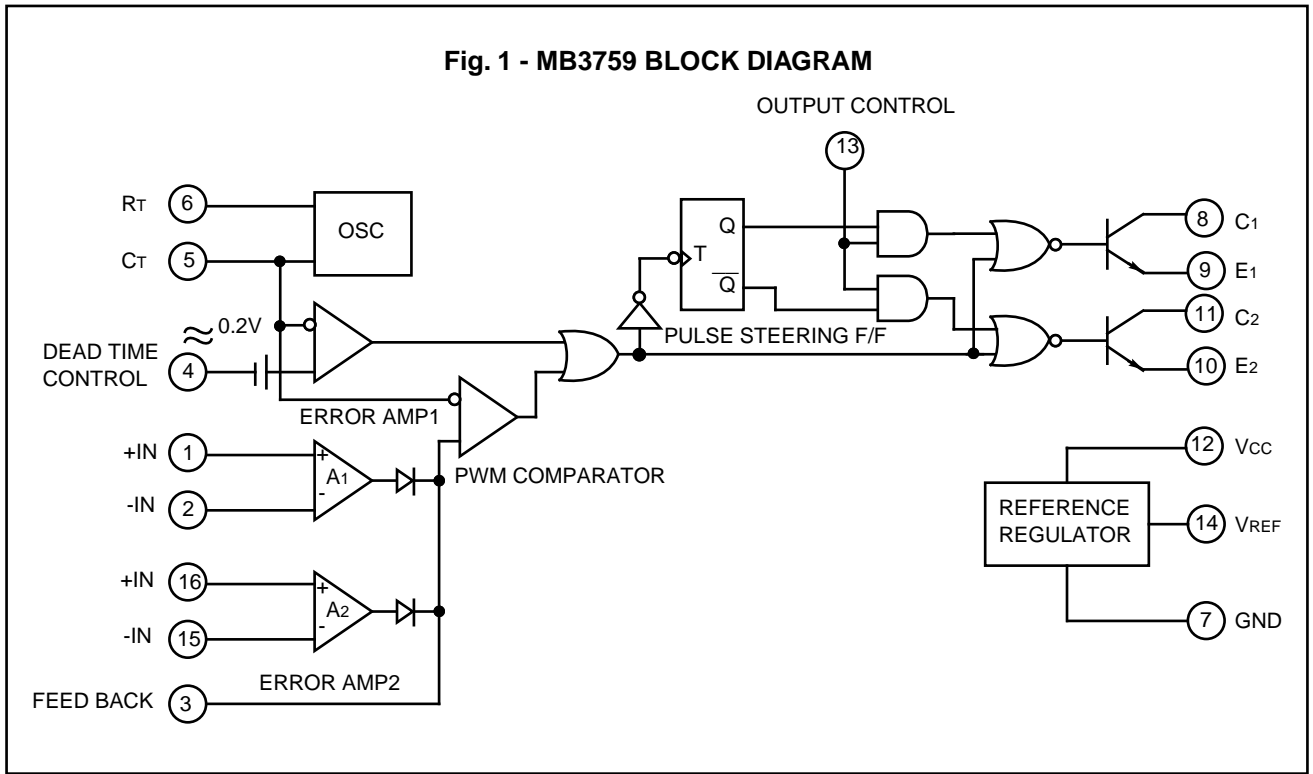

RECOMMENDED OPERATING CONDITIONS

Parameter	Symbol	DIP-package			FPT-package			Unit
		Min	Typ	Max	Min	Typ	Max	
Power Supply Voltage	VCC	7	15	32	7	15	24	V
Collector Output Voltage	VCE	-	-	40	-	-	40	V
Collector Output Current	ICE	5	100	200	5	50	100	mA
Amplifier Input Voltage	VIN	-0.3	0 to VREF	VCC -2	-0.3	0 to VREF	VCC -2	V
FB Sink Current	ISINK	-	-	0.3	-	-	0.3	mA
FB Source Current	ISOURCE	-	-	2	-	-	2	mA
Reference Section Output Current	IREF	-	5	10	-	3	10	mA
Timing Resistor	RT	1.8	30	500	1.8	30	500	kΩ
Timing Capacitor	CT	470	1000	10 ⁶	470	1000	10 ⁶	pF
Oscillator Frequency	fOSC	1	40	300	1	40	300	kHz
Operating Temperature	TA	-20	25	85	-20	25	75	°C

Note: These recommended operating conditions are based on the standard condition.

When used at higher supply voltage, careful consideration for the ambient temperature, power consumption and so on is necessary.

ELECTRICAL CHARACTERISTICS

(TA=25°C, VCC=15V)

Parameter	Symbol	Condition	Value			Unit
			Min	Typ	Max	

Reference Section

Output Voltage	ΔV_{REF}	$I_O=1mA$	4.75	5.0	5.25	V
Input Regulation	ΔV_{RIN}	$7V \leq V_{CC} \leq 40V, T_A=25^\circ C$	-	2	25	mV
Load Regulation	ΔV_{RLD}	$1mA \leq I_O \leq 10mA, T_A=25^\circ C$	-	-1	-15	mV
Temperature Stability	$\Delta V_{R}/\Delta T$	$-20^\circ C \leq T_A \leq 85^\circ C$	-	± 200	± 750	$\mu V/^\circ C$
Short Circuit Output Current	ISC		15	40	-	mA
Reference Lockout Voltage			-	4.3	-	V
Reference Hysteresis Voltage			-	0.3	-	V

■ ELECTRICAL CHARACTERISTICS (continued)

Parameter	Symbol	Condition	Value			Unit
			Min	Typ	Max	

Oscillator Section

Oscillator Frequency	fosc	RT=30kΩ, CT=1000pF	36	40	44	kHz
Standard Deviation of Frequency		RT=30kΩ, CT=1000pF	-	±3	-	%
Frequency Change with Voltage		7V ≤ VCC ≤ 40V, TA=25°C	-	±0.1	-	%
Frequency Change with Temperature	Δfosc/ΔT	-20°C ≤ TA ≤ 85°C	-	±0.01	±0.03	%/°C

Dead-Time Control Section

Input Bias Current	ID	0 ≤ VI ≤ 5.25V	-	-2	-10	μA
Maximum Duty Cycle (Each Output)		VI=0	40	45	-	%
Input Threshold Voltage	0% Duty Cycle	VDO	-	3.0	3.3	V
	Max. Duty Cycle	VDM	0	-	-	V

Error Amplifier Section

Input Offset Voltage	VIO	VO (pin3) = 2.5V	-	±2	±10	mV
Input Offset Current	IIO	VO (pin3) = 2.5V	-	±25	±250	nA
Input Bias Current	II	VO (pin3) = 2.5V	-	-0.2	-1.0	μA
Common-Mode Input Voltage	VCM	7V ≤ VCC ≤ 40V	-0.3	-	VCC -2	V
Open-Loop Voltage Amplification	AV	0.5 ≤ VO ≤ 3.5V	70	95	-	dB
Unity-Gain Bandwidth	BW	AV = 1	-	800	-	kHz
Common-Mode Rejection Ratio	CMR	VCC = 40V	65	80	-	dB
Output Sink Current (3pin)	ISINK	-5V ≤ VID ≤ -15mV, VO=0.7V	0.3	0.7	-	mA
Output Source Current (3pin)	ISOURCE	15mV ≤ VID ≤ 5V, VO=3.5V	-2	-10	-	mA

■ ELECTRICAL CHARACTERISTICS (continued)

Parameter	Symbol	Condition	Value			Unit
			Min	Typ	Max	

Output Section

Collector Leakage Current		ICO	VCE=40V, VCC=40V	-	-	100	μA
Emitter Leakage Current		IEO	VCC=VC=40V, VE=0V	-	-	-100	μA
Collector Emitter Saturation Voltage	Emitter Grounded	VSATC	VE=0, IC=200mA	-	1.1	1.3	V
	Emitter Follower	VSATE	VC=15V, IE=-200mA	-	1.5	2.5	V
Output Control Input Current		IOPC	VI=VREF	-	1.3	3.5	mA

PWM Comparator Section

Input Threshold Voltage	VTH	0% Duty	-	4	4.5	V
Input Sink Current (3pin)	ISINK	VO(pin3)=0.7V	0.3	0.7	-	mA

Total Device

Power Supply Current	ICC	V4=2V, See Fig-2	-	8	-	mA
Stand-by Current	ICCQ	V(pin6)=VREF, I/O open	-	7	12	mA

Switching Characteristics

Rise Time	Emitter Grounded	tR	RL=68Ω	-	100	200	ns
Fall Time		tF	RL=68Ω	-	25	100	na
Rise Time	Emitter Follower	tR	RL=68Ω	-	100	200	ns
Fall Time		tF	RL=68Ω	-	40	100	ns

■ TYPICAL ELECTRICAL CURVES

Fig. 4 - REFERENCE VOLTAGE vs. POWER SUPPLY VOLTAGE

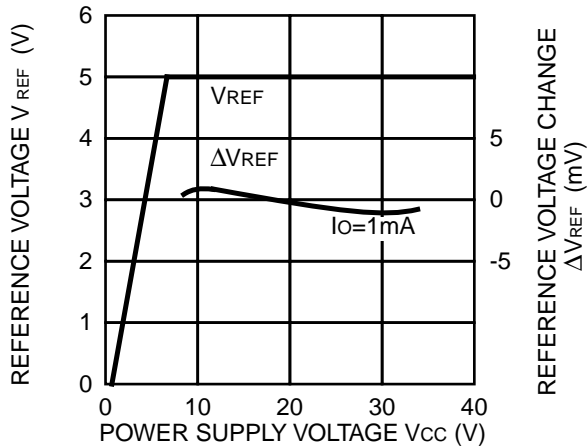

Fig. 5 - REFERENCE VOLTAGE vs. TEMPERATURE

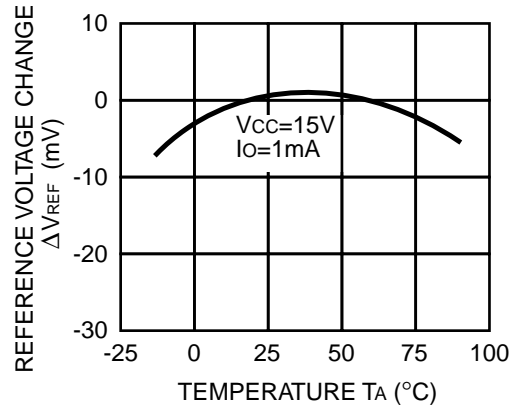

Fig. 6 - OSCILLATOR FREQUENCY vs. RT, CT

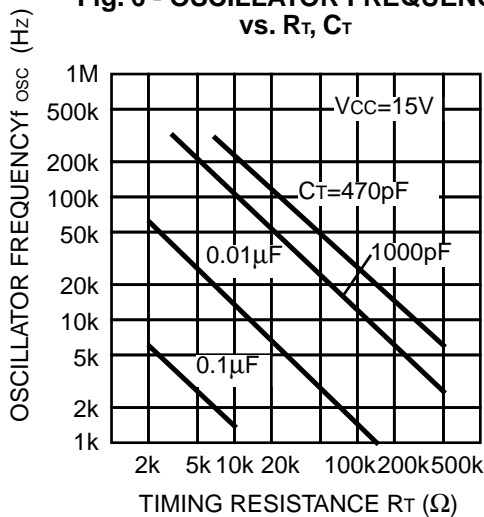

Fig. 7 - DUTY RATIO vs. DEAD TIME CONTROL VOLTAGE

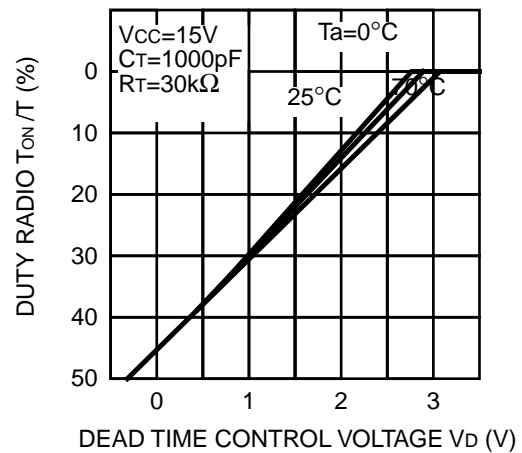

Fig. 8 - OPEN LOOP VOLTAGE AMPLIFICATION vs. FREQUENCY

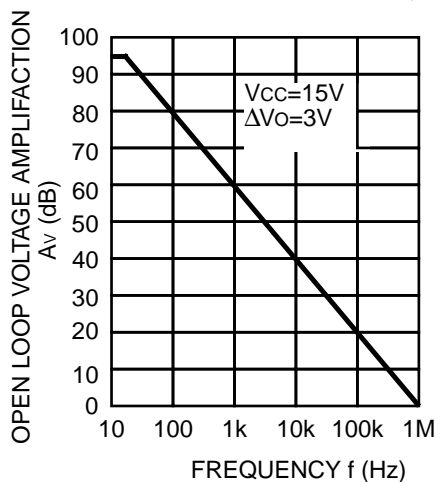
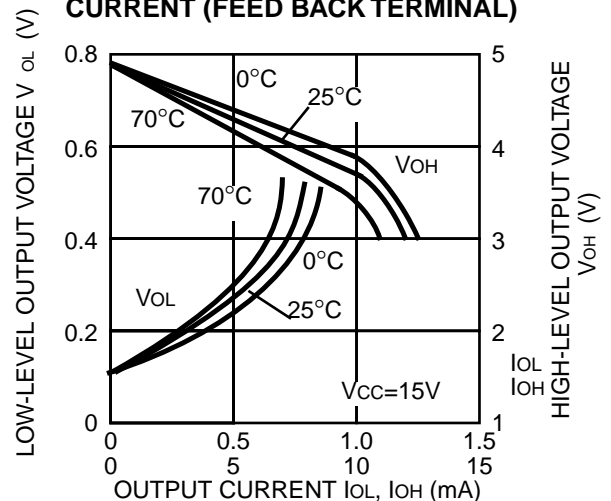

Fig. 9 - OUTPUT VOLTAGE vs. OUTPUT CURRENT (FEED BACK TERMINAL)



■ TYPICAL ELECTRICAL CURVES (Continued)

Fig. 10 - COLLECTOR SATURATION VOLTAGE vs. COLLECTOR OUTPUT CURRENT

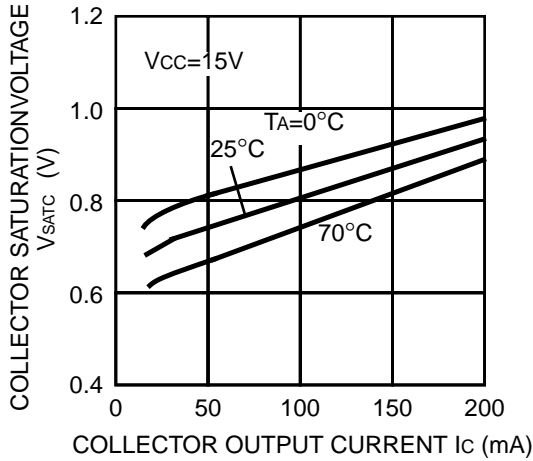

Fig. 12 - OUTPUT VOLTAGE vs. REFERENCE VOLTAGE

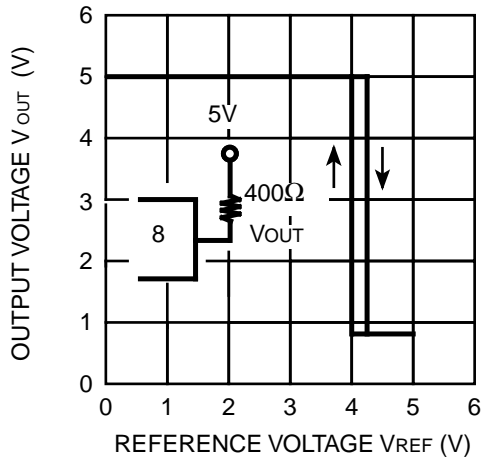

Fig. 14 - POWER DISSIPATION vs. POWER SUPPLY VOLTAGE

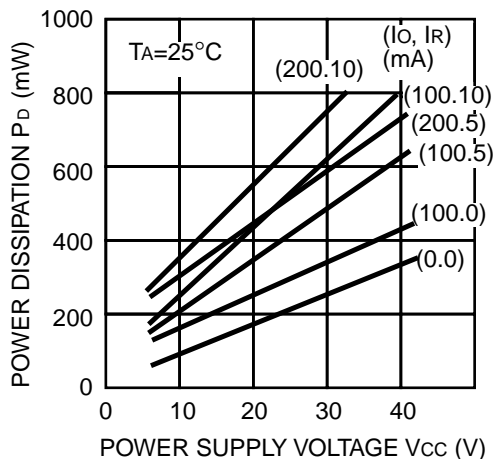

Fig. 11 - EMITTER SATURATION VOLTAGE vs. EMITTER OUTPUT CURRENT

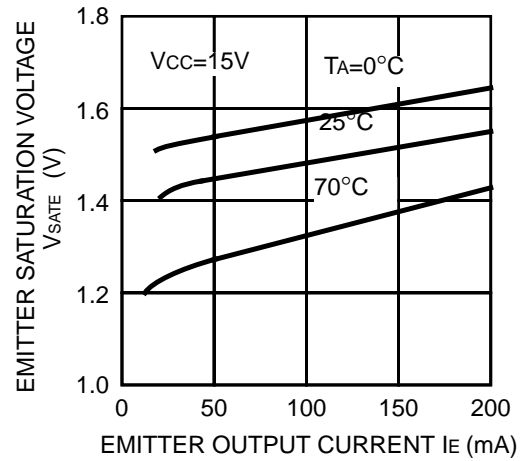

Fig. 13 - POWER SUPPLY CURRENT vs. POWER SUPPLY VOLTAGE

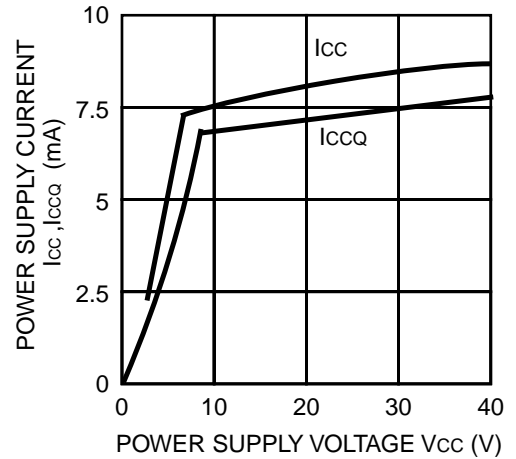
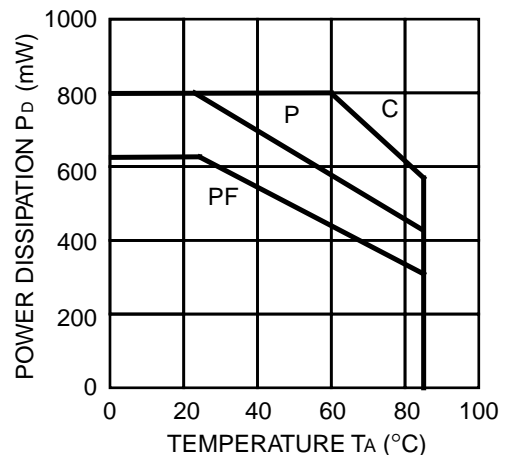

Fig. 15 - AVAILABLE POWER DISSIPATION vs. TEMPERATURE



Note: I_O is collector output current at emitter grounded mode.

Note: C (Ceramic DIP) P (Plastic DIP) PF (Plastic FPT)

■ TYPICAL APPLICATION

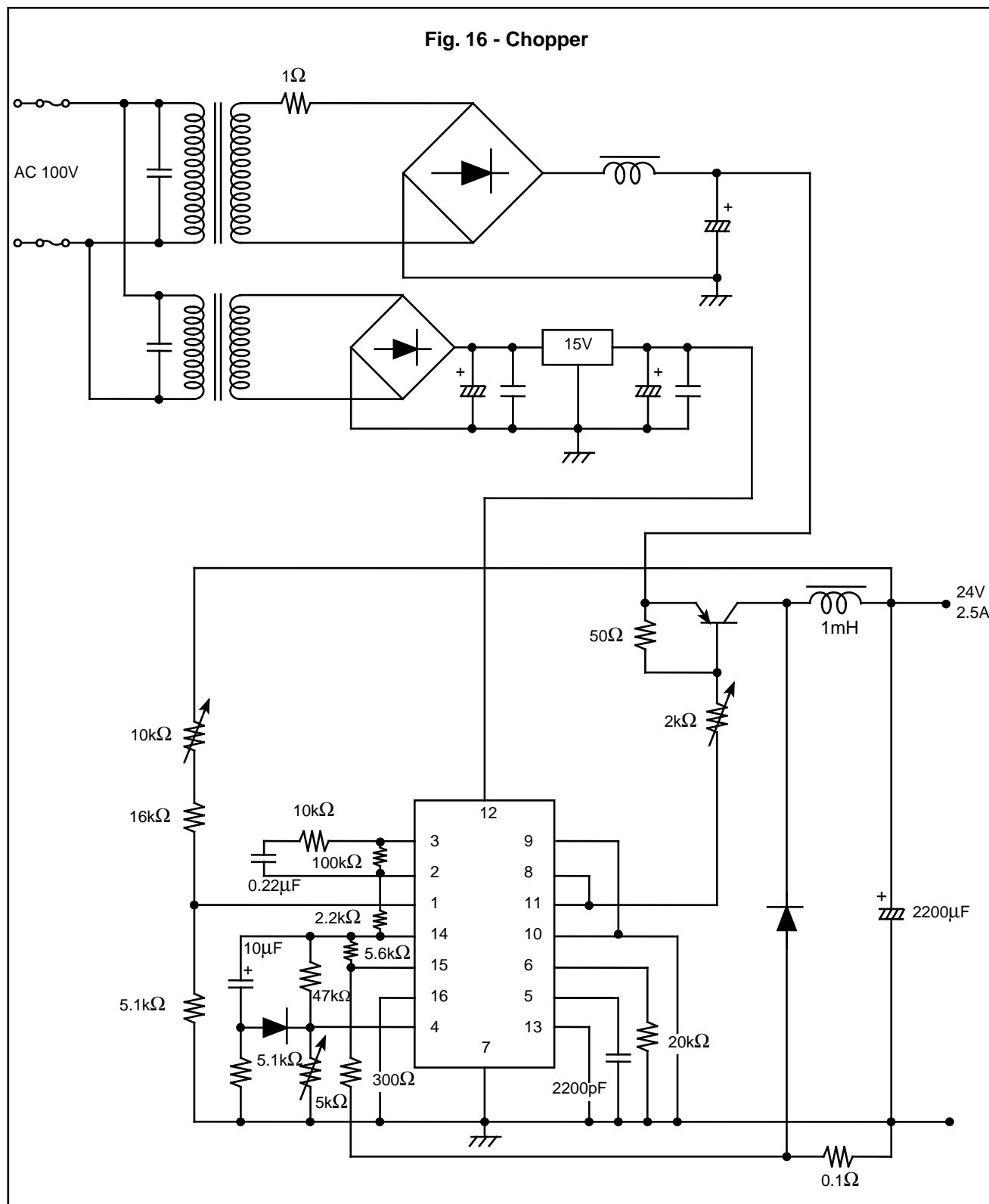

■ TYPICAL APPLICATION (continued)

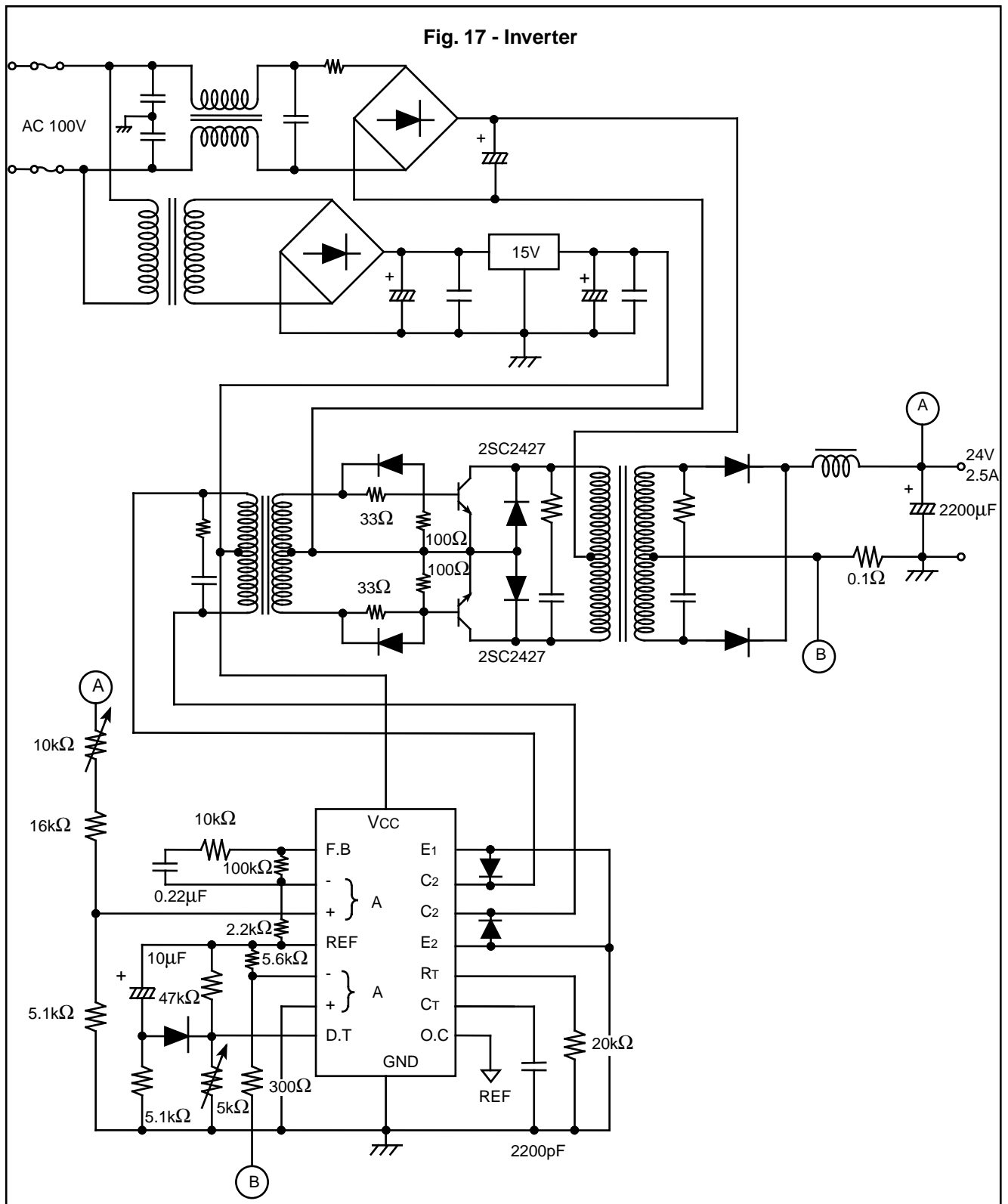

■ PACKAGE DIMENSIONS

16 pin, Plastic DIP
(DIP-16P-M04)

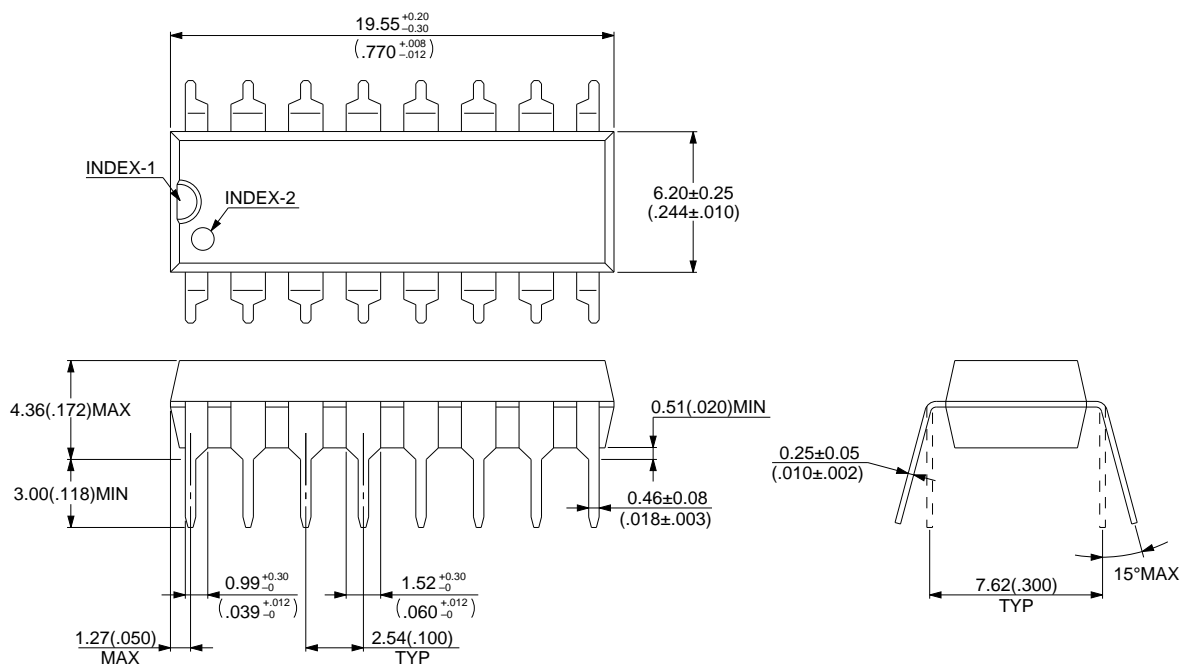

© 1994 FUJITSU LIMITED D16033S-2C-3

Dimensions in mm(inches).

■ PACKAGE DIMENSIONS (continued)

16 pin, Plastic SOP
(FPT-16P-M06)

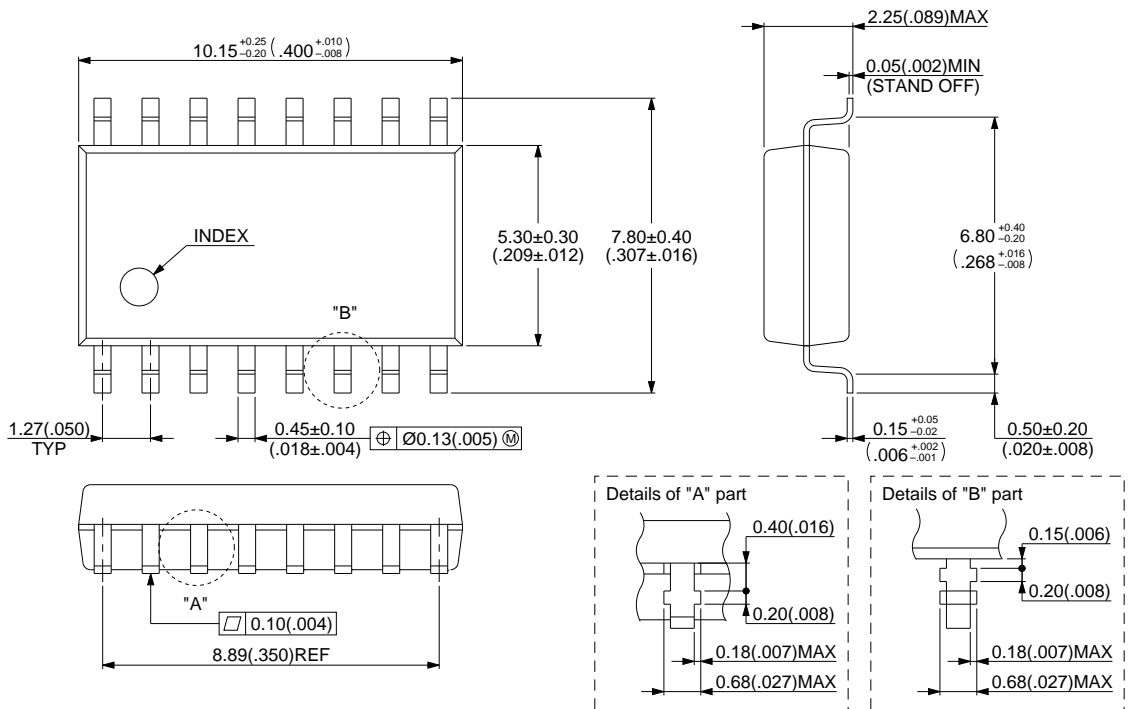

© 1994 FUJITSU LIMITED F16015S-2C-4

Dimensions in mm(inches).

■ PACKAGE DIMENSIONS (continued)

16 pin, Ceramic DIP
(DIP-16C-C01)

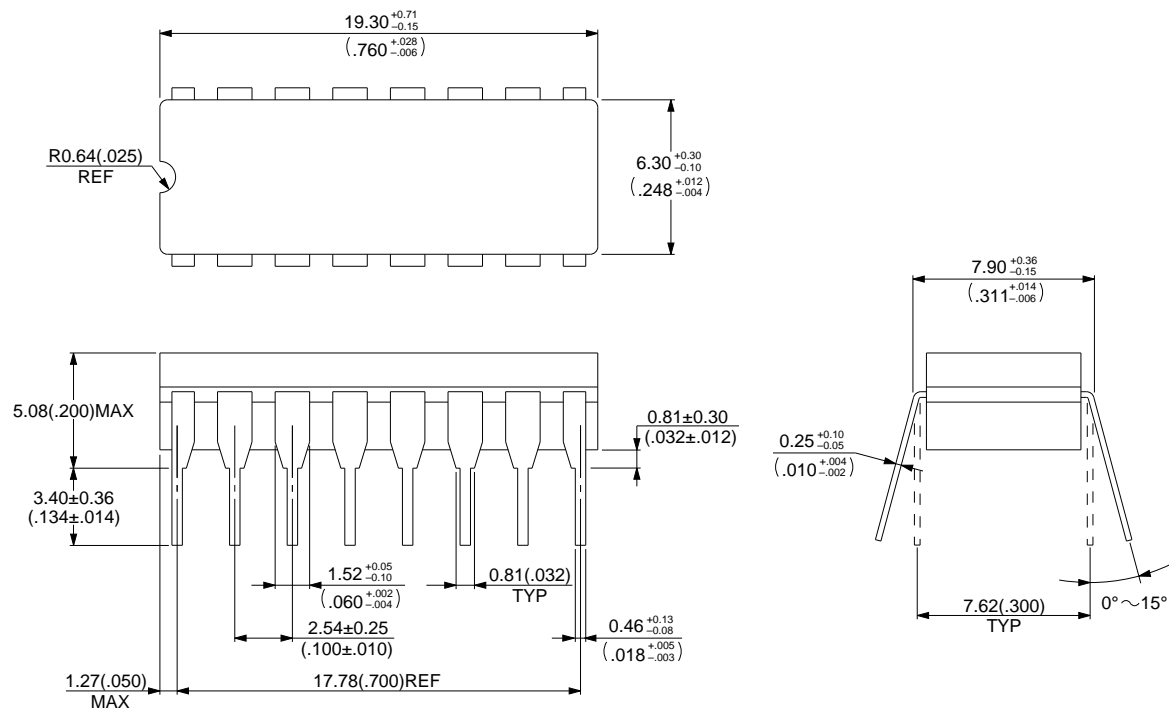

© 1994 FUJITSU LIMITED D16011SC-2-3

Dimensions in mm(inches).

FUJITSU LIMITED

For further information please contact:

Japan

FUJITSU LIMITED
Corporate Global Business Support Division
Electronic Devices
KAWASAKI PLANT, 4-1-1, Kamikodanaka
Nakahara-ku, Kawasaki-shi
Kanagawa 211-88, Japan
Tel: (044) 754-3763
Fax: (044) 754-3329

North and South America

FUJITSU MICROELECTRONICS, INC.
Semiconductor Division
3545 North First Street
San Jose, CA 95134-1804, U.S.A.
Tel: (408) 922-9000
Fax: (408) 432-9044/9045

Europe

FUJITSU MIKROELEKTRONIK GmbH
Am Siebenstein 6-10
63303 Dreieich-Buchsschlag
Germany
Tel: (06103) 690-0
Fax: (06103) 690-122

Asia Pacific

FUJITSU MICROELECTRONICS ASIA PTE. LIMITED
#05-08, 151 Lorong Chuan
New Tech Park
Singapore 556741
Tel: (65) 281-0770
Fax: (65) 281-0220

All Rights Reserved.

The contents of this document are subject to change without notice. Customers are advised to consult with FUJITSU sales representatives before ordering.

The information and circuit diagrams in this document presented as examples of semiconductor device applications, and are not intended to be incorporated in devices for actual use. Also, FUJITSU is unable to assume responsibility for infringement of any patent rights or other rights of third parties arising from the use of this information or circuit diagrams.

FUJITSU semiconductor devices are intended for use in standard applications (computers, office automation and other office equipment, industrial, communications, and measurement equipment, personal or household devices, etc.).

CAUTION:

Customers considering the use of our products in special applications where failure or abnormal operation may directly affect human lives or cause physical injury or property damage, or where extremely high levels of reliability are demanded (such as aerospace systems, atomic energy controls, sea floor repeaters, vehicle operating controls, medical devices for life support, etc.) are requested to consult with FUJITSU sales representatives before such use. The company will not be responsible for damages arising from such use without prior approval.

Any semiconductor devices have inherently a certain rate of failure. You must protect against injury, damage or loss from such failures by incorporating safety design measures into your facility and equipment such as redundancy, fire protection, and prevention of over-current levels and other abnormal operating conditions.

If any products described in this document represent goods or technologies subject to certain restrictions on export under the Foreign Exchange and Foreign Trade Control Law of Japan, the prior authorization by Japanese government should be required for export of those products from Japan.

F9703

© FUJITSU LIMITED Printed in Japan