

ASSP For Power Supply Applications

BIPOLAR

Switching Regulator Controller (Low Voltage)

MB3800

■ DESCRIPTION

The MB3800 is a single-channel switching regulator control IC for low voltage applications incorporating a soft start function and short circuit detection function. The device has a low minimum operating voltage of 1.8 V and is ideal for the power supply of battery-operated electronic equipment.

■ FEATURES

- Wide supply voltage operating range: 1.8 to 15 V
- Low current consumption: Typically 5.5 mA in operation, 1 μ A or less in stand-by
- High speed operation is possible: Maximum 1 MHz
- The error amplifier gain is set inside the IC, so peripheral components are minimized.
- Incorporates a soft start circuit.
- Incorporates a timer-latch type short circuit detection circuit (SCP).
- Totem-pole type output with adjustable on/off current (for NPN transistors)
- Incorporates a stand-by function.
- Three types of packages (SOP-8 or SOL-8, SSOP-8)

■ PACKAGES

8-pin Plastic SOP

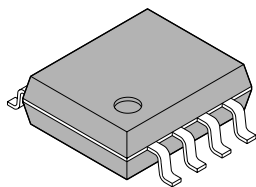

(FPT-8P-M01)

8-pin Plastic SOL

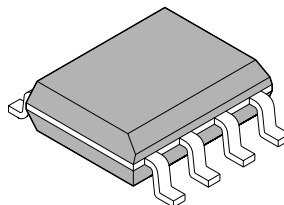

(FPT-8P-M02)

8-pin Plastic SSOP

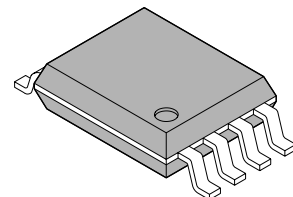

(FPT-8P-M03)

MB3800

■ PIN ASSIGNMENT

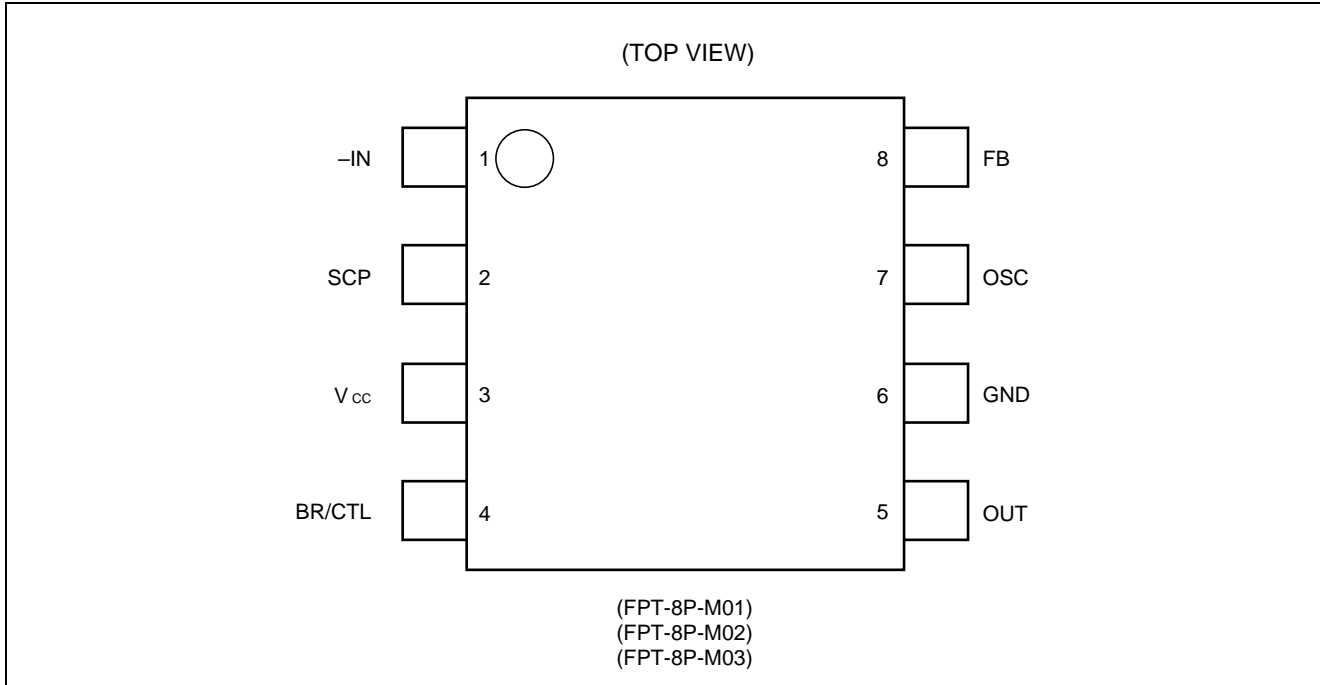

■ PIN DESCRIPTION

Pin No.	Symbol	I/O	Description
1	-IN	I	Error amplifier inverting input pin
2	SCP	—	Soft start and SCP setting capacitor connection pin
3	VCC	—	Power supply pin
4	BR/CTL	I	Output current setting and control pin
5	OUT	O	Totem-pole type output pin
6	GND	—	Ground pin
7	OSC	—	Capacitor and resistor connection pin for setting the oscillation frequency
8	FB	O	Error amplifier output pin

■ BLOCK DIAGRAM

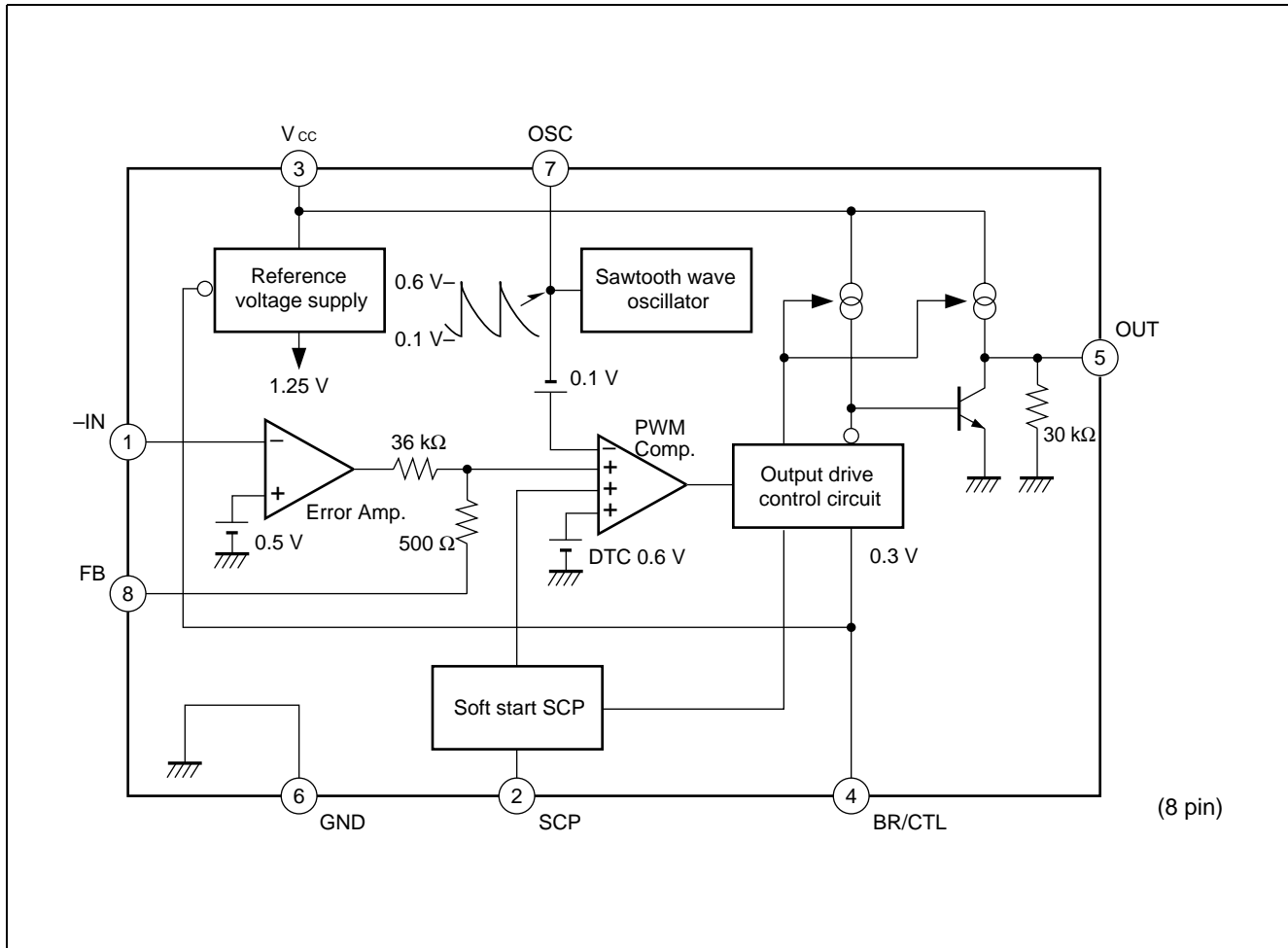

MB3800

■ ABSOLUTE MAXIMUM RATINGS

(Ta = +25°C)

Parameter	Symbol	Condition	Rated Value		Unit
			Min.	Max.	
Power supply voltage	V _{CC}	—	—	16	V
Output source current	I _O ⁺		—	-50	mA
Output sink current	I _O ⁻		—	50	mA
Allowable dissipation	P _D	SOP-8, Ta ≤ +25°C	—	570*	mW
		SOP-8, Ta ≤ +25°C	—	430*	mW
		SSOP-8, Ta ≤ +25°C	—	580*	mW
Operating temperature	T _{op}	—	-30	+85	°C
Storage temperature	T _{stg}		-55	+125	°C

* : When mounted on a 10 cm square double-sided epoxy board

WARNING: Semiconductor devices can be permanently damaged by application of stress (voltage, current, temperature, etc.) in excess of absolute maximum ratings. Do not exceed these ratings.

■ RECOMMENDED OPERATING CONDITIONS

(Ta = +25°C)

Parameter	Symbol	Values			Unit
		Min.	Typ.	Max.	
Power supply voltage	V _{CC}	1.8	—	15	V
Error amplifier input voltage	V _I	-0.2	—	1.0	V
BR/CTL pin input voltage	V _{BR}	-0.2	—	V _{CC}	V
Output source current	I _O ⁺	-40	—	—	mA
Output sink current	I _O ⁻	—	—	40	mA
SCP pin capacitance	C _{PE}	—	0.1	—	μF
Phase compensation capacitance	C _P	—	0.1	—	μF
Output current setting resistance	R _B	150	390	5000	Ω
Timing resistance	R _T	1.0	3.0	10.0	kΩ
Timing capacitance	C _T	100	270	10000	pF
Oscillation frequency	f _{OSC}	10	500	1000	kHz
Operating temperature	T _{OP}	-30	+25	+85	°C

WARNING: Recommended operating conditions are normal operating ranges for the semiconductor device. All the device's electrical characteristics are warranted when operated within these ranges.

Always use semiconductor devices within the recommended operating conditions. Operation outside these ranges may adversely affect reliability and could result in device failure.

No warranty is made with respect to uses, operating conditions, or combinations not represented on the data sheet. Users considering application outside the listed conditions are advised to contact their FUJITSU representative beforehand.

■ ELECTRICAL CHARACTERISTICS

($V_{CC} = +2\text{ V}$, $T_a = +25^\circ\text{C}$)

Parameter		Symbol	Condition	Value			Unit
				Min.	Typ.	Max.	
Circuit to prevent malfunction at low input voltage (U.V.L.O.)	Reset voltage	V_R	—	—	—	0.9	V
	Threshold voltage	V_{TH}		1.1	1.3	1.5	V
Soft start	Charging current	I_{CS}	$V_{SCP} = 0\text{ V}$	-1.5	-1.0	-0.7	μA
	Voltage at soft start completion	V_{IS}	—	0.7	0.8	0.9	V
Short circuit detection (S.C.P.)	Charging current	I_{CPC}	$V_{SCP} = 0\text{ V}$	-1.5	-1.0	-0.7	μA
	Threshold voltage	V_{IPC}	—	0.7	0.8	0.9	V
Sawtooth wave oscillator (OSC)	Oscillation frequency	f_{OCS}	$R_T = 3.0\text{ k}\Omega$, $C_T = 270\text{ pF}$	400	500	600	kHz
	Frequency input stability	f_{dV}	$V_{CC} = 2\text{ V to }15\text{ V}$	—	2	10	%
	Frequency variation with temperature	f_{dT}	$T_a = -30^\circ\text{C to }+85^\circ\text{C}$	—	5	—	%
Error amplifier	Input threshold voltage	V_T	$V_{FB} = 450\text{ mV}$	480	500	520	mV
	V_T input stability	V_{TdV}	$V_{CC} = 2\text{ V to }15\text{ V}$	—	5	20	mV
	V_T variation with temperature	V_{TdT}	$T_a = -30^\circ\text{C to }+85^\circ\text{C}$	—	1	—	%
	Input bias current	I_B	$V_{IN} = 0\text{ V}$	-1.0	-0.2	1.0	μA
	Voltage gain	A_V	—	70	100	145	V/V
	Frequency bandwidth	BW	$A_V = 0\text{ dB}$	—	6	—	MHz
	Maximum output voltage range	V_{OM+}	—	0.78	0.87	—	V
		V_{OM-}		—	0.05	0.2	V
	Output source current	I_{OM+}	$V_{FB} = 0.45\text{ V}$	—	-40	-24	μA
Output sink current	I_{OM-}	24		40	—	μA	
Idle period adjustment section	Maximum duty cycle	t_{DUTY}	$R_T = 3.0\text{ k}\Omega$, $C_T = 270\text{ pF}$ $V_{FB} = 0.8\text{ V}$	65	75	85	%

(Continued)

MB3800

(Continued)

Parameter		Symbol	Condition	Value			Unit
				Min.	Typ.	Max.	
Output section	Output voltage	V_{OH1}	$R_B = 390 \Omega, I_o = -15 \text{ mA}$	1.0	1.2	—	V
		V_{OH2}	$R_B = 750 \Omega, V_{CC} = 1.8 \text{ V}$ $I_o = -10 \text{ mA}$	0.8	1.0	—	V
		V_{OL1}	$R_B = 390 \Omega, I_o = 15 \text{ mA}$	—	0.1	0.2	V
		V_{OL2}	$R_B = 750 \Omega, V_{CC} = 1.8 \text{ V}$ $I_o = 10 \text{ mA}$	—	0.1	0.2	V
	Output source current	I_o^+	$R_B = 390 \Omega, V_o = 0.9 \text{ V}$	—	-30	-20	mA
	Output sink current	I_o^-	$R_B = 390 \Omega, V_o = 0.3 \text{ V}$	30	60	—	mA
	Pull down resistance	R_o	—	20	30	40	k Ω
Output current setting section/ Control section	Pin voltage	V_{BR}	$R_B = 390 \Omega$	0.2	0.3	0.4	V
	Input off condition	I_{OFF}	—	-20	—	0	μA
	Input on condition	I_{ON}	—	—	—	-45	μA
	Pin current range	I_{BR}	—	-1.8	—	-0.1	mA
Entire device	Stand-by current	I_{CCS}	BR/CTL pin open or V_{CC}	—	—	1	μA
	Average supply current	I_{CC}	$R_B = 390 \Omega$	—	5.5	9.3	mA

■ DIAGRAM

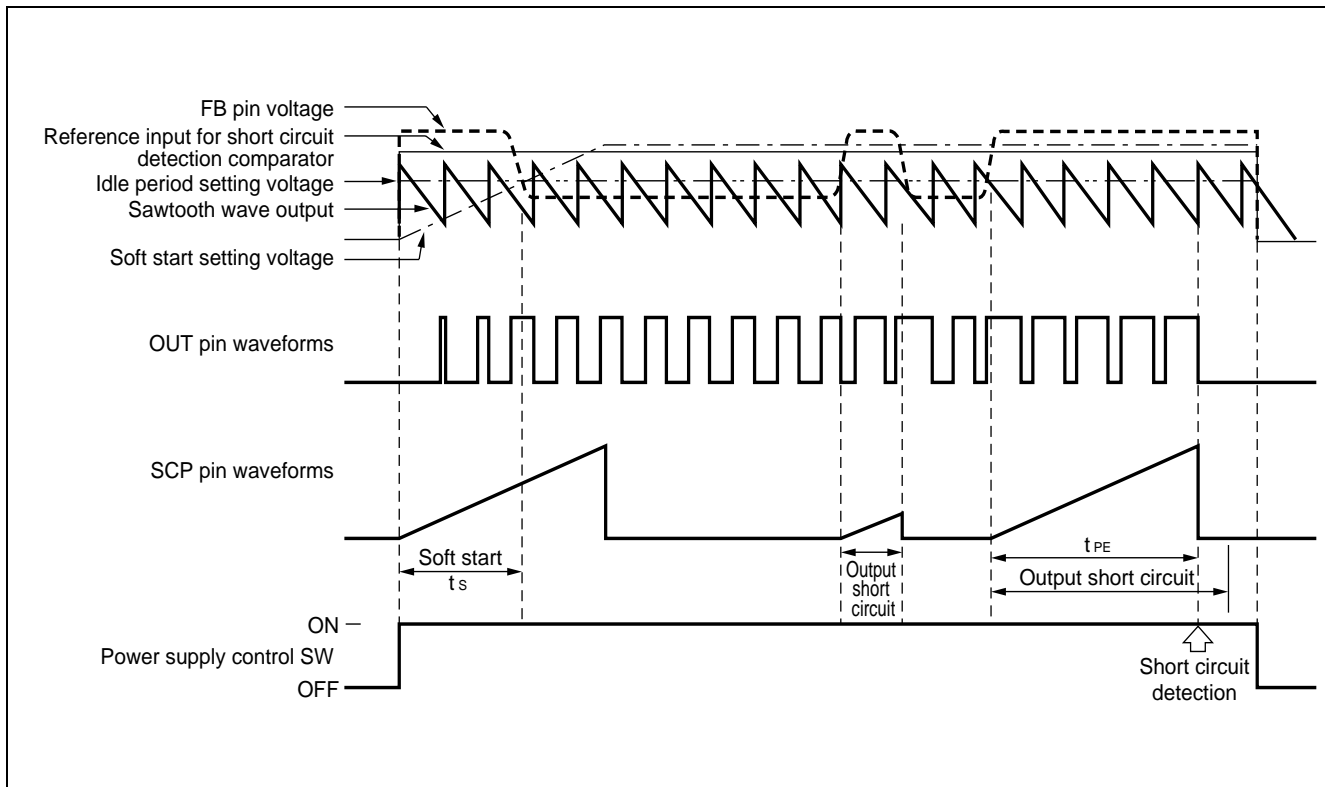

■ HOW TO SET THE TIME CONSTANT FOR SOFT START AND SHORT CIRCUIT DETECTION

1. Soft Start

At power on, the capacitor C_{PE} connected to the SCP pin starts charging. The PWM comparator compares the soft start setting voltage as a proportion of the voltage at the SCP pin with the sawtooth waveform. The comparison controls the ON duty of the OUT pin, causing the soft start operation. On completion of soft start operation, the voltage at the SCP pin stays low, the soft start setting voltage stays high, and the circuit enters the output short circuit detection wait state.

Soft start time (The time until the output ON duty reaches approximately 50%)

$$t_s [s] \cong 0.35 \times C_{PE} [\mu F]$$

2. Short Circuit Protection

If the switching regulator output suddenly drops due to load effect, the error amplifier output (FB pin) is fixed at V_{OM}^+ and capacitor C_{PE} starts charging. When the voltage at the SCP pin reaches approximately 0.8V, the output pin is set low and the SCP pin stays low.

Once the protection circuit operates, the circuit can be restored by resetting the power supply.

- Short circuit detection time

$$t_{PE} [s] \cong 0.8 \times C_{PE} [\mu F]$$

TYPICAL CHARACTERISTICS

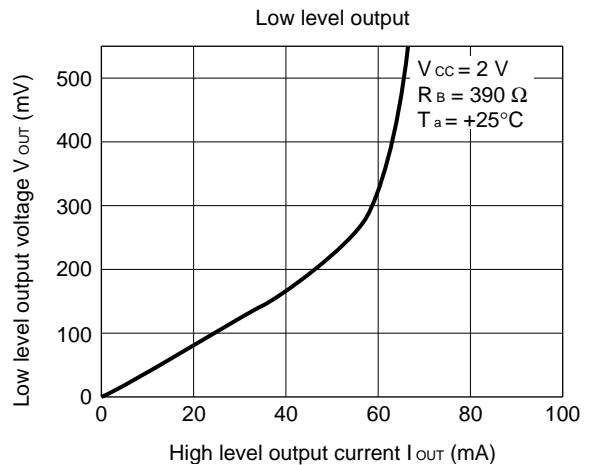
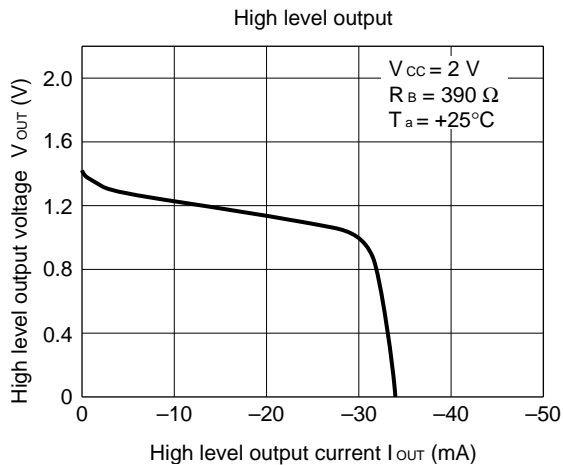
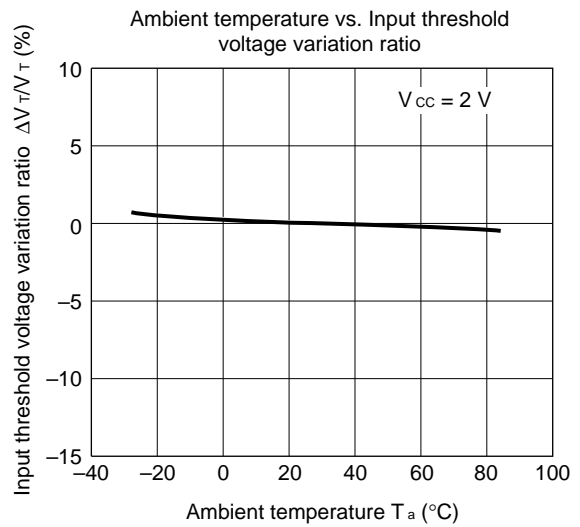
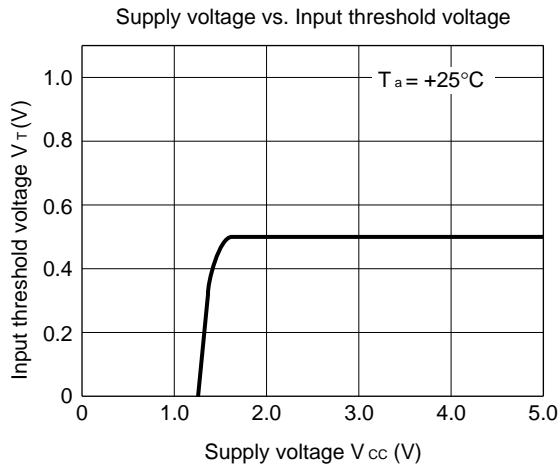
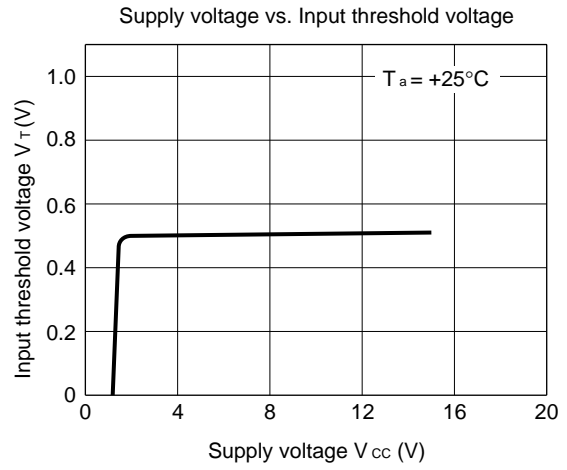
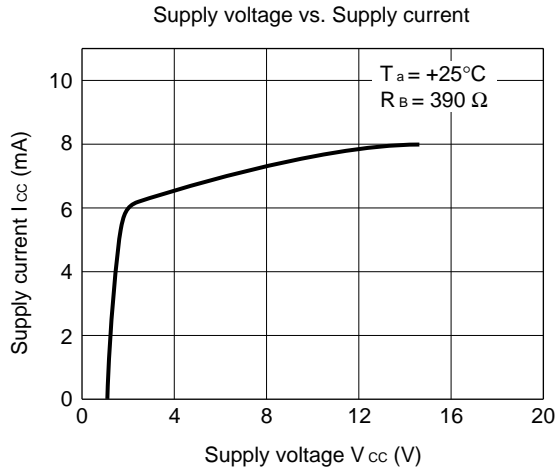

(Continued)

(Continued)

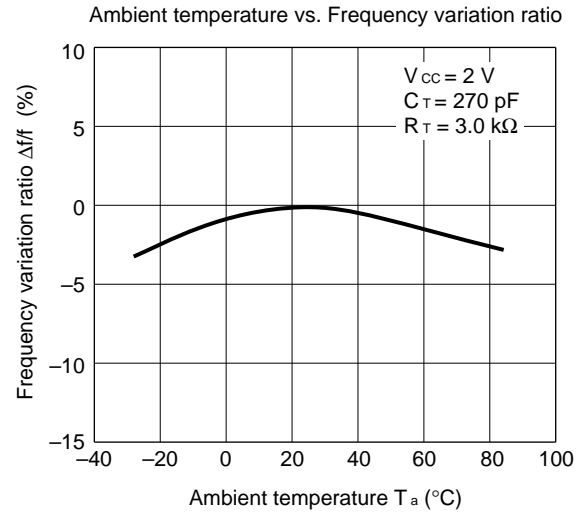
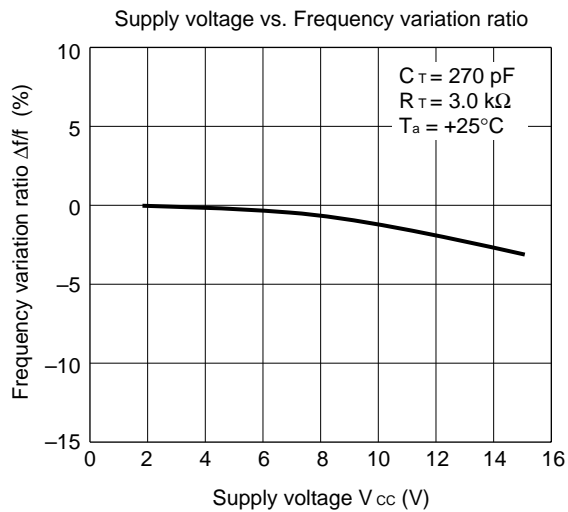
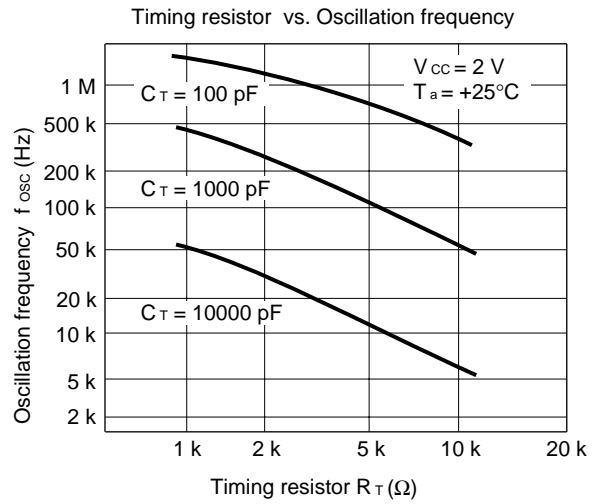
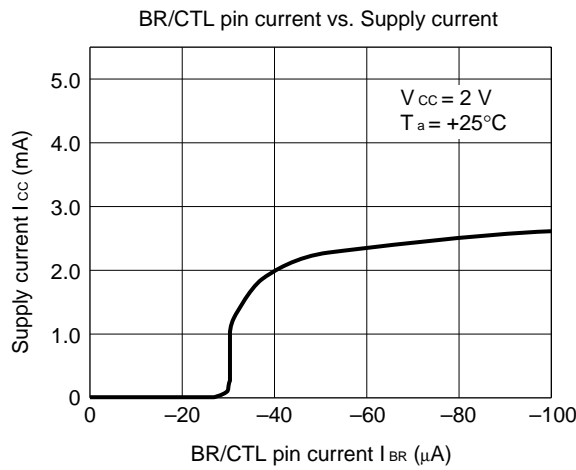
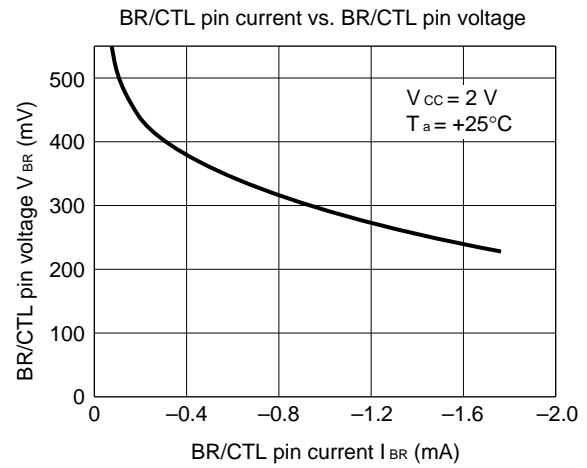
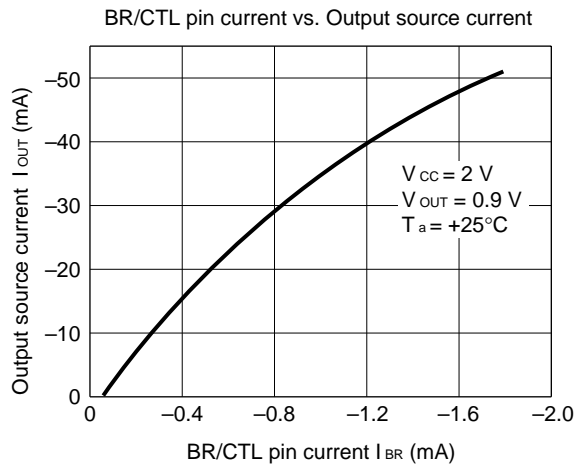

(Continued)

(Continued)

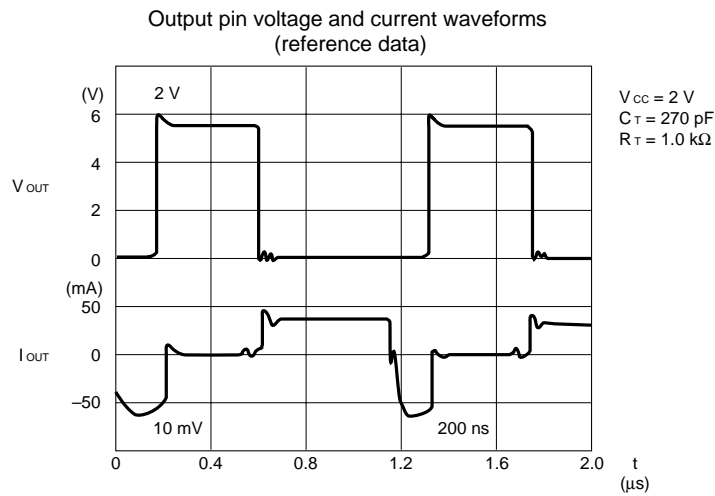
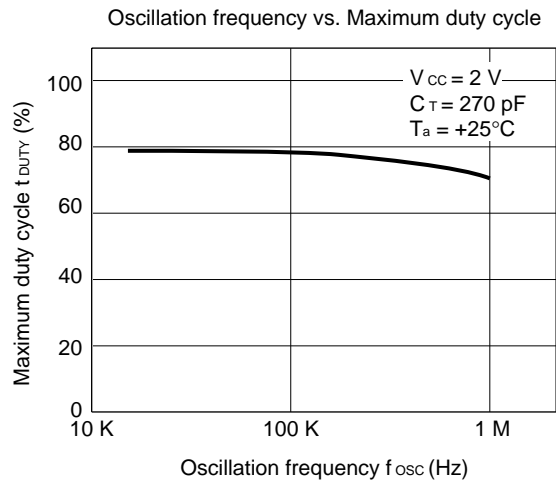

Note: The OFF delay time of V_{OUT} depends on the characteristics of the external transistor.

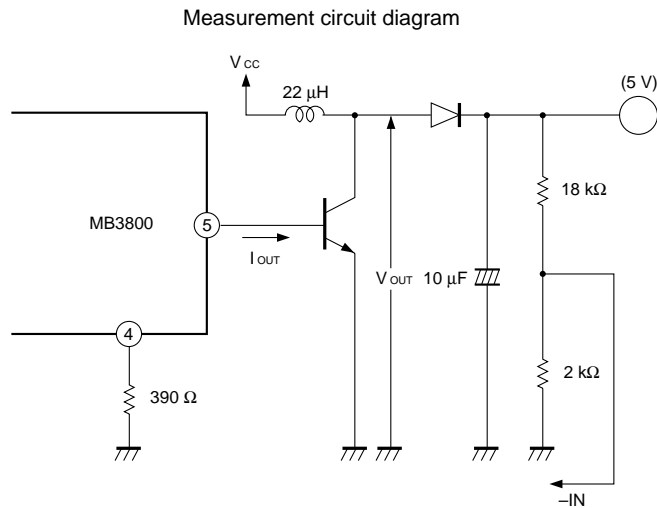

■ FUNCTIONAL DESCRIPTION

1. Switching Regulator Function

(1) Reference voltage circuit

The reference voltage circuit generates a temperature-compensated reference voltage ($\cong 1.25V$) from voltage supplied from the power supply pin (pin 3). In addition to providing the reference voltage for the switching regulator, the circuit also sets the idle period.

(2) Sawtooth wave oscillator

The sawtooth oscillator generates a sawtooth wave (up to 1 MHz) that is stable with respect to the supply voltage and temperature. The capacitor and resistor that set the oscillation frequency are connected to the OSC pin (pin 7).

(3) Error amplifier (Error Amp.)

The error amplifier detects the output voltage of the switching regulator and outputs the PWM control signal. The voltage gain is fixed, and connecting a phase compensation capacitor to the FB pin (pin 8) provides stable phase compensation for the system.

(4) PWM comparator (PWM Comp.)

The voltage comparator has one inverting and three non-inverting inputs. The comparator is a voltage/pulse width converter that controls the ON time of the output pulse depending on the input voltage. The output level is high (H) when the sawtooth wave is lower than the error amplifier output voltage, soft start setting voltage, and idle period setting voltage.

(5) Output circuit

The output circuit has a totem pole type configuration and can drive an external NPN transistor directly. The value of the ON/OFF current can be set by a resistor connected to the BR/CTL pin (pin 4).

2. Power Supply Control Function

Stand-by mode (supply current $1 \mu A$ or less) can be set by connecting the BR/CTL pin (pin 4) to V_{CC} or by making the pin open circuit.

SW	Mode
OFF	Stand-by mode
ON	Operating mode

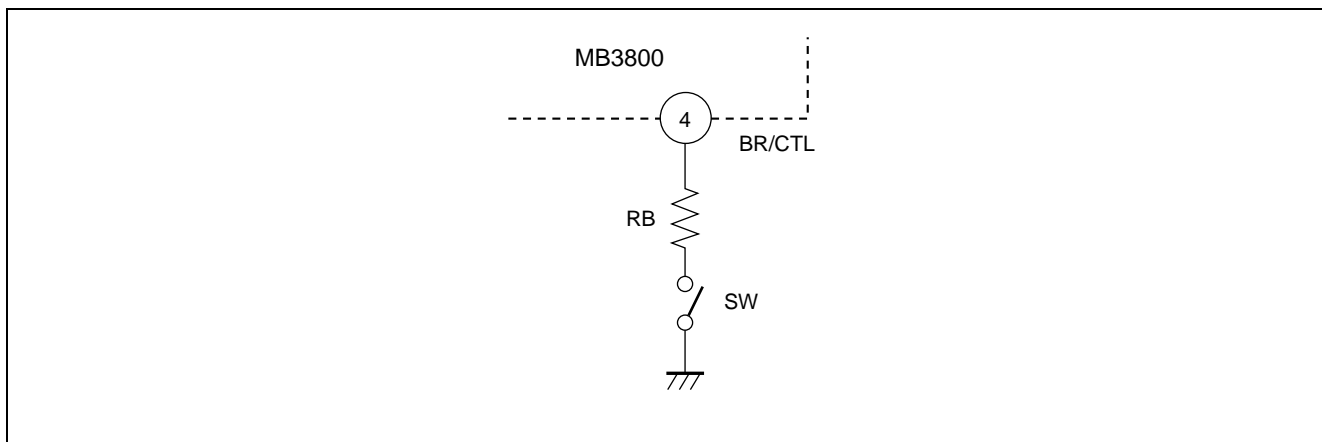

3. Other Functions

(1) Soft start and short circuit detection

Soft start operation is set by connecting capacitor C_{PE} to the SCP pin (pin 2). Soft start prevents a current spike on start-up.

On completion of soft start operation, the SCP pin (pin 2) stays low and enters the short circuit detection wait state. When an output short circuit occurs, the error amplifier output is fixed at V_{OM+} and capacitor C_{PE} starts charging. After charging to approximately 0.8 V, the output pin (pin 5) is set low and the SCP pin (pin 2) stays low.

Once the protection circuit operates, the circuit can be restored by resetting the power supply. (See “**■ HOW TO SET THE TIME CONSTANT FOR SOFT START AND SHORT CIRCUIT DETECTION**”.)

(2) Circuit to prevent malfunction at low input voltage

Transients when powering on or instantaneous glitches in the supply voltage can lead to malfunction of the control IC and cause system damage or failure. The circuit to prevent malfunction at low input voltage detects a low input voltage by comparing the supply voltage to the internal reference voltage. On detection, the circuit fixes the output pin to low.

The system recovers when the supply voltage rises back above the threshold voltage of the malfunction prevention circuit.

■ APPLICATION EXAMPLE

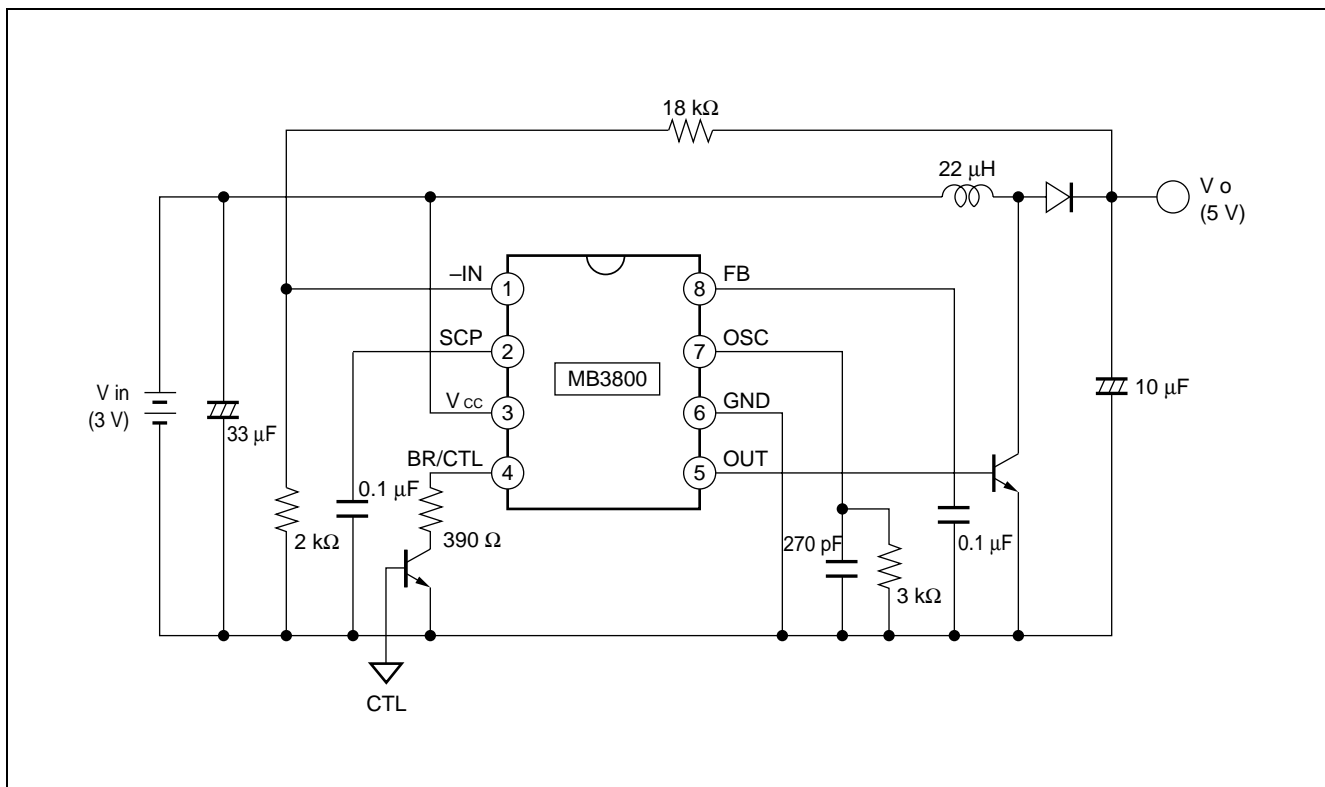

■ USAGE PRECAUTIONS

1. Do not apply an input voltage greater than the maximum rating.

Do not input voltages greater than the maximum rating as this can cause damage to the LSI.

2. Use in accordance with the recommended operating conditions.

The electrical characteristics of the LSI are not guaranteed if the input voltage is greater than the maximum. Also, LSI operation is unstable if the input voltage is less than the minimum. Therefore, always use in accordance with the recommended operating conditions.

3. Use a wide ground line on the printed circuit board.

As the LSI uses a high frequency and therefore can generate high frequency noise, make the ground line as wide as possible.

4. Take anti-static precautions.

- Use a holder for inserting the semiconductor which is anti-static or conductive.
- After mounting the device on a printed circuit board, store or transport the board in a conductive bag or container.
- Earth work benches, tools, and measuring equipment.
- Ensure that maintenance personnel have a resistance of 250 k Ω to 1 M Ω in series between their body and earth.

MB3800

■ ORDERING INFORMATION

Part number	Package	Remarks
MB3800PF	8-pin Plastic SOP (FPT-8P-M01)	
MB3800PNF	8-pin Plastic SOL (FPT-8P-M02)	
MB3800PFV	8-pin Plastic SSOP (FPT-8P-M03)	

■ PACKAGE DIMENSIONS

8-pin Plastic SOP
(FPT-8P-M01)

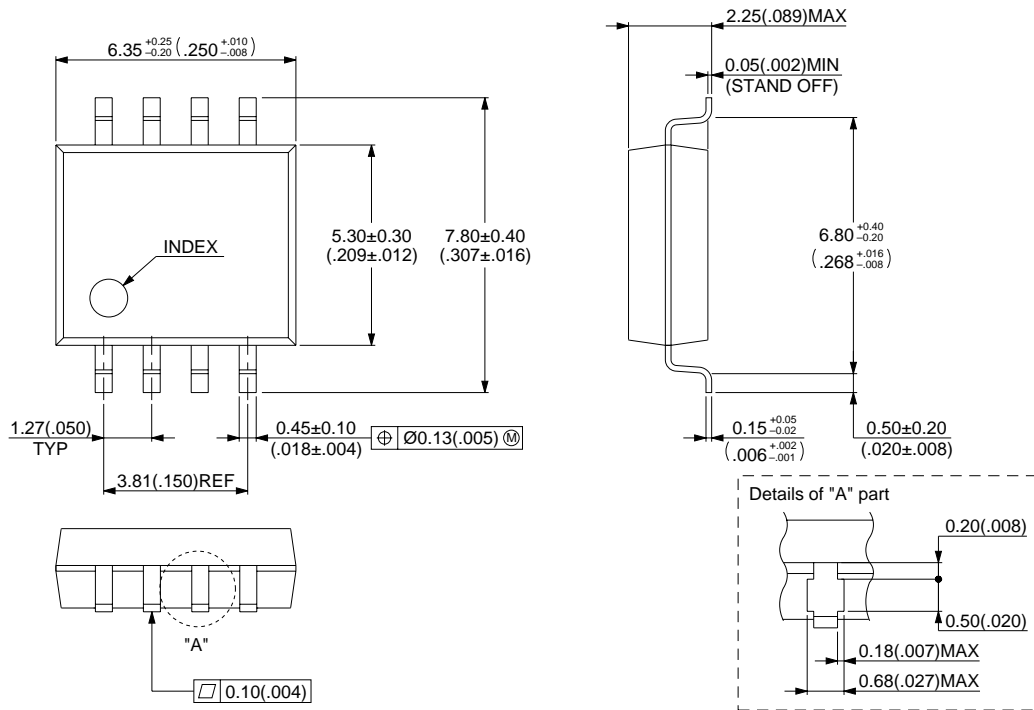

© 1994 FUJITSU LIMITED F08002S-4C-4

Dimensions in mm (inches).

(Continued)

MB3800

(Continued)

8-pin Plastic SOL (FPT-8P-M02)

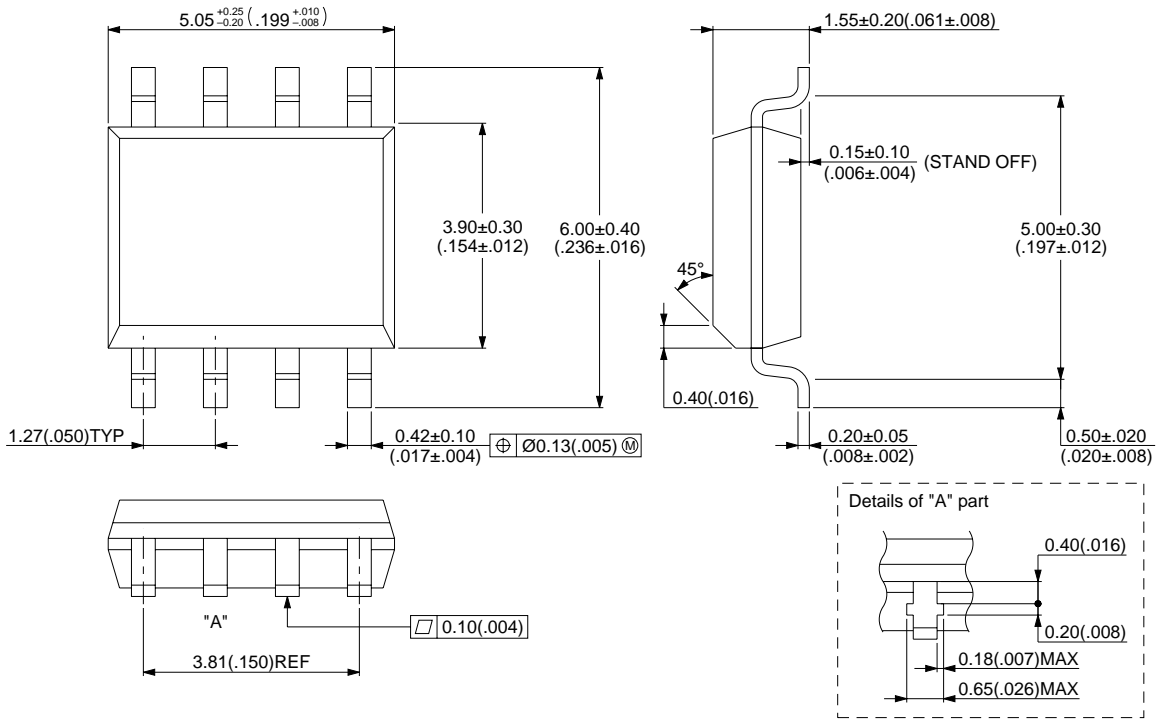

© 1994 FUJITSU LIMITED F08004S-2C-4

Dimensions in mm (inches).

(Continued)

8-pin Plastic SSOP (FPT-8P-M03)

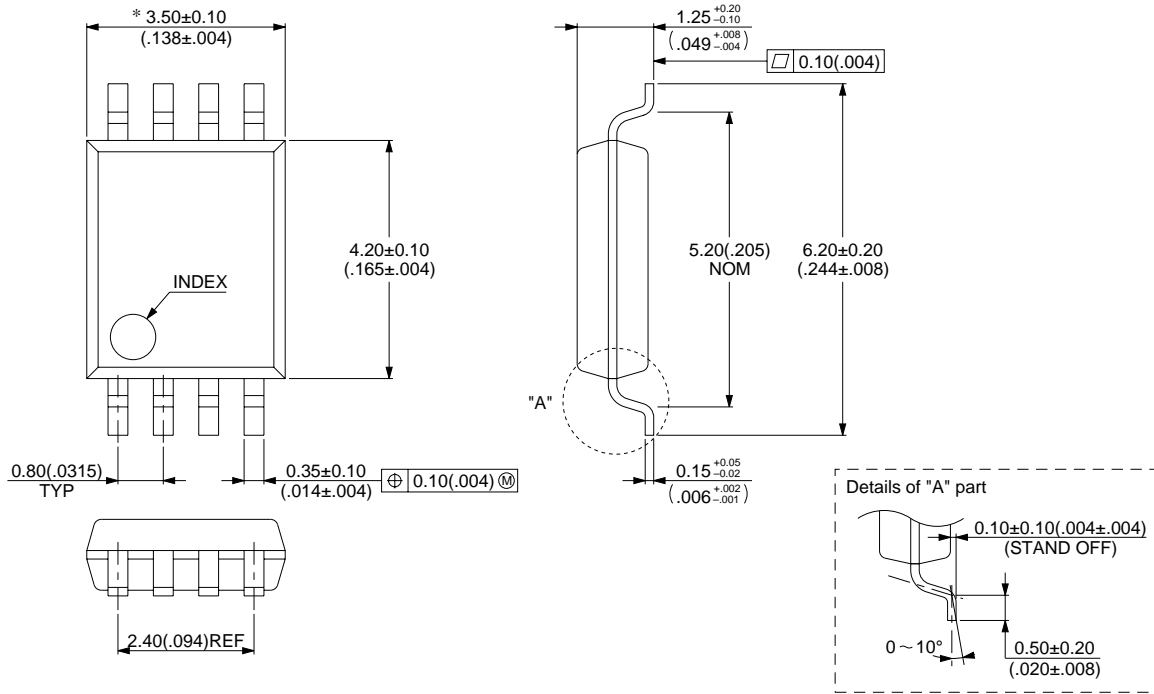

© 1994 FUJITSU LIMITED F08005S-1C-2

Dimensions in mm (inches).

FUJITSU LIMITED

For further information please contact:

Japan

FUJITSU LIMITED
Corporate Global Business Support Division
Electronic Devices
KAWASAKI PLANT, 4-1-1, Kamikodanaka
Nakahara-ku, Kawasaki-shi
Kanagawa 211-8588, Japan
Tel: (044) 754-3763
Fax: (044) 754-3329

<http://www.fujitsu.co.jp/>

North and South America

FUJITSU MICROELECTRONICS, INC.
Semiconductor Division
3545 North First Street
San Jose, CA 95134-1804, USA
Tel: (408) 922-9000
Fax: (408) 922-9179

Customer Response Center
Mon. - Fri.: 7 am - 5 pm (PST)
Tel: (800) 866-8608
Fax: (408) 922-9179

<http://www.fujitsumicro.com/>

Europe

FUJITSU MIKROELEKTRONIK GmbH
Am Siebenstein 6-10
D-63303 Dreieich-Buchsschlag
Germany
Tel: (06103) 690-0
Fax: (06103) 690-122

<http://www.fujitsu-edc.com/>

Asia Pacific

FUJITSU MICROELECTRONICS ASIA PTE LTD
#05-08, 151 Lorong Chuan
New Tech Park
Singapore 556741
Tel: (65) 281-0770
Fax: (65) 281-0220

<http://www.fmap.com.sg/>

F9802

© FUJITSU LIMITED Printed in Japan

All Rights Reserved.

The contents of this document are subject to change without notice. Customers are advised to consult with FUJITSU sales representatives before ordering.

The information and circuit diagrams in this document presented as examples of semiconductor device applications, and are not intended to be incorporated in devices for actual use. Also, FUJITSU is unable to assume responsibility for infringement of any patent rights or other rights of third parties arising from the use of this information or circuit diagrams.

FUJITSU semiconductor devices are intended for use in standard applications (computers, office automation and other office equipment, industrial, communications, and measurement equipment, personal or household devices, etc.).

CAUTION:

Customers considering the use of our products in special applications where failure or abnormal operation may directly affect human lives or cause physical injury or property damage, or where extremely high levels of reliability are demanded (such as aerospace systems, atomic energy controls, sea floor repeaters, vehicle operating controls, medical devices for life support, etc.) are requested to consult with FUJITSU sales representatives before such use. The company will not be responsible for damages arising from such use without prior approval.

Any semiconductor devices have inherently a certain rate of failure. You must protect against injury, damage or loss from such failures by incorporating safety design measures into your facility and equipment such as redundancy, fire protection, and prevention of over-current levels and other abnormal operating conditions.

If any products described in this document represent goods or technologies subject to certain restrictions on export under the Foreign Exchange and Foreign Trade Control Law of Japan, the prior authorization by Japanese government should be required for export of those products from Japan.