

ASSP

1 CHANNEL 8-BIT VIDEO A/D CONVERTER

MB40578

■ DESCRIPTION

The Fujitsu MB40578 is a low power ultra-high speed video A/D converter fabricated with Fujitsu Advanced Bipolar Technology. The MB40578 also adopts the fully-parallel comparison technique (flash method) for high speed conversion and can convert wide band analog signal such as video signal to digital signal at a sampling rate of DC through 20 Mega-samples/sec. Because of such high-speed operation, the MB40578 is suitable for digital video applications such as the digital TV, video processing with computer, or radar signal processing.

■ FEATURES

- Resolution: 8 bits
- Linearity error: $\pm 0.2\%$ max. (MB40578)
- Maximum conversion rate: 20 MSPS min.
- Analog input voltage: 3.0V to 5.0V
- Digital I/O level: TTL compatible
- Single power supply: +5V
- Power Dissipation: 480mW typ.
- Package: Standard 22-pin DIP Package: Suffix: -P

■ PACKAGE

Plastic DIP, 22 pin

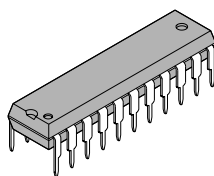

(DIP-22P-M04)

MB40578

■ PIN ASSIGNMENT

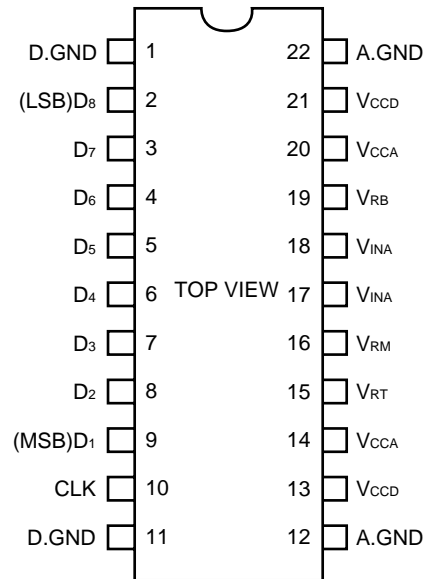

■ BLOCK DIAGRAM

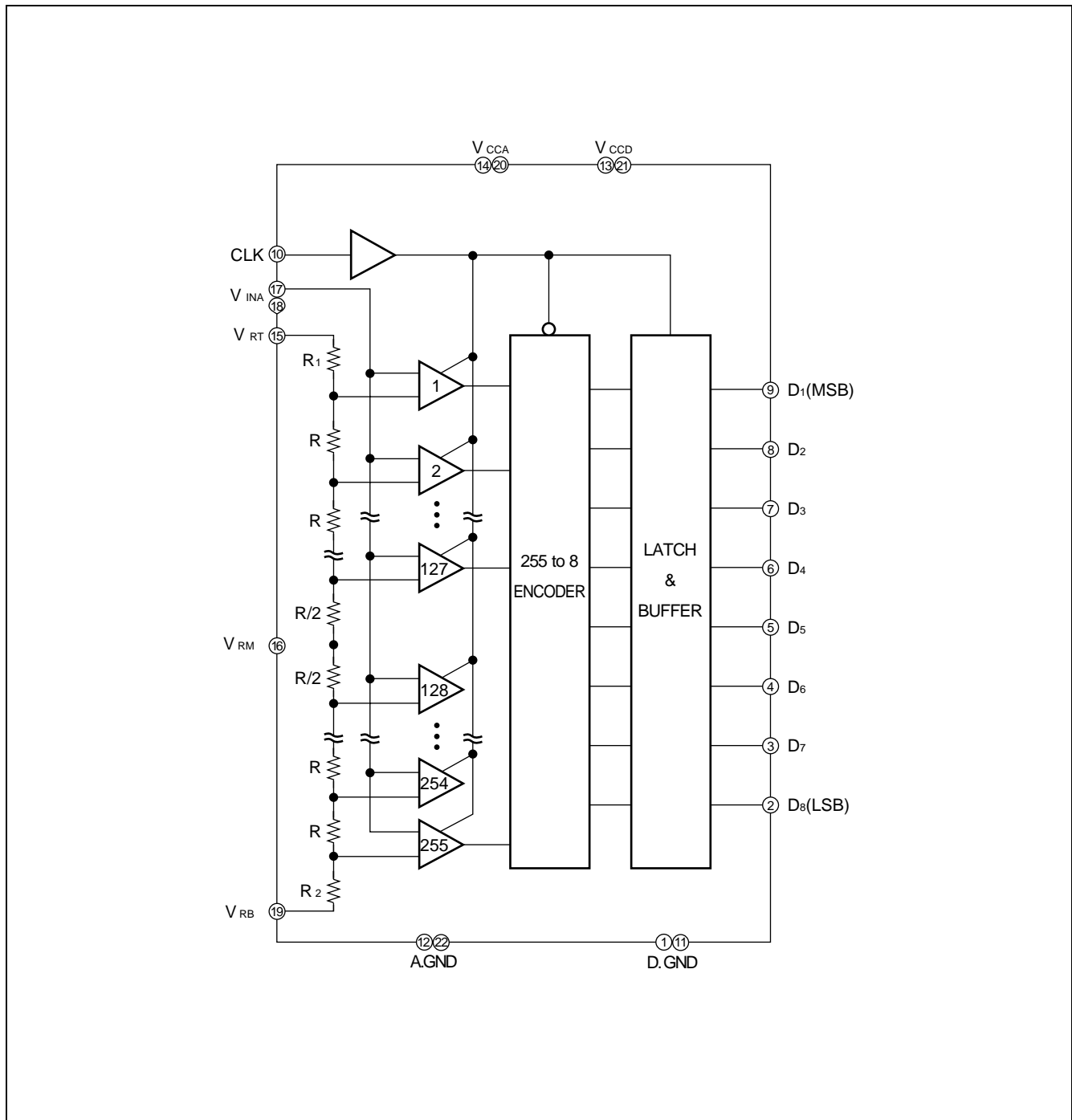

MB40578

■ ABSOLUTE MAXIMUM RATINGS

Parameter	Symbol	Rating	Unit
Power supply voltage	V _{CCA} V _{CCD}	-0.5 to +7.0	V
Digital input voltage	V _{IND}	-0.5 to +7.0	V
Analog input voltage	V _{INA}	-0.5 to V _{CC} +0.5	V
Analog reference voltage	V _{RT} , V _{RB}	-0.5 to V _{CC} +0.5	V
Storage temperature	V _{STG}	-55 to +125	°C

Note: Permanent device damage may occur if the above Absolute Maximum Ratings are exceeded. Functional operation should be restricted to the conditions as detailed in the operational sections of this data sheet. Exposure to absolute maximum rating conditions for extended periods may affect device reliability.

■ RECOMMENDED OPERATING CONDITIONS

Parameter	Symbol	Value			Unit
		Min	Typ	Max	
Power supply voltage*1	V _{CCA} V _{CCD}	4.75	5.00	5.25	V
Analog input voltage*2	V _{INA}	3	—	5	V
Analog reference voltage (Top side)*2	V _{RT}	—	5	5.1	V
Analog reference voltage (Bottom side)*2	V _{RB}	2.9	3	—	V
Digital high-level output current	I _{OHD}	-400	—	—	μA
Digital low-level output current	I _{OLD}	—	—	4	mA
Clock pulse width at high level	t _{w+}	25	—	—	ns
Clock pulse width at low level	t _{w-}	25	—	—	ns
Operating temperature	T _a	0	—	70	°C

Notes: *1: Please keep V_{CCA} and V_{CCD} at the same potential.

*2: V_{RB} < V_{INA} < V_{RT}, V_{RT} - V_{RB} = 2V + 0.1V.

■ ELECTRICAL CHARACTERISTICS

1. Analog DC Characteristics

($V_{CCA} = V_{CCD} = 5V \pm 5\%$, $T_a = 0$ to 70°C)

Parameter	Symbol	Condition	Value			Unit
			Min	Typ	Max	
Resolution			—	—	8	bits
Linearity error	LE	DC	—	—	± 0.2	%
Equivalent resistance for analog input	R_{INA}		50	—	—	$k\Omega$
Analog input capacitance	C_{INA}		—	120	230	μF
Analog high-level input current	I_{IHA}		—	—	150	μA
Analog low-level input current	I_{ILA}		—	—	145	μA
Reference current	I_{RB}	$V_{RT} = 5V$ $V_{RB} = 3V$	-15	-9	—	mA

2. Digital DC Characteristics

($V_{CCA} = V_{CCD} = 5V \pm 5\%$, $T_a = 0$ to 70°C)

Parameter	Symbol	Condition	Value			Unit
			Min	Typ	Max	
High-level output voltage	V_{OH}	$I_{OH} = -400 \mu\text{A}$	2.7	—	—	V
Low-level output voltage	V_{OL}	$I_{OL} = 1.6 \text{ mA}$	—	—	0.4	V
High-level input voltage	V_{IHD}		2	—	—	V
Low-level input voltage	V_{ILD}		—	—	0.8	V
Maximum input current	I_{ID}	$V_{ID} = 7V$	—	—	100	μA
High-level input current	I_{IHD}	$V_{IHD} = 2.7V$	—	0	20	μA
Low level input current	I_{ILD}	$V_{ILD} = 0.4V$	-400	-40	—	μA
Power supply current	I_{CC}		—	92	160	mA

3. Switching Characteristics

($V_{CCA} = V_{CCD} = 5V \pm 5\%$, $T_a = 0$ to 70°C)

Parameter	Symbol	Condition	Value			Unit
			Min	Typ	Max	
Maximum conversion rate	FS		20	30	—	MSPS
Digital output delay time	tpd		5	15	40	ns

Figure 1 Timing Diagram

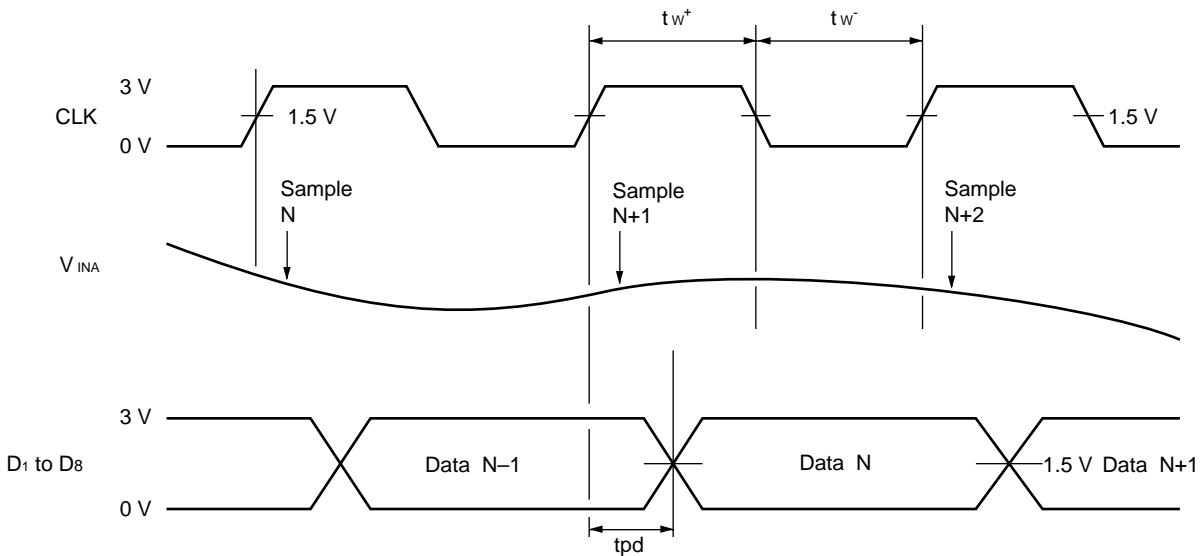
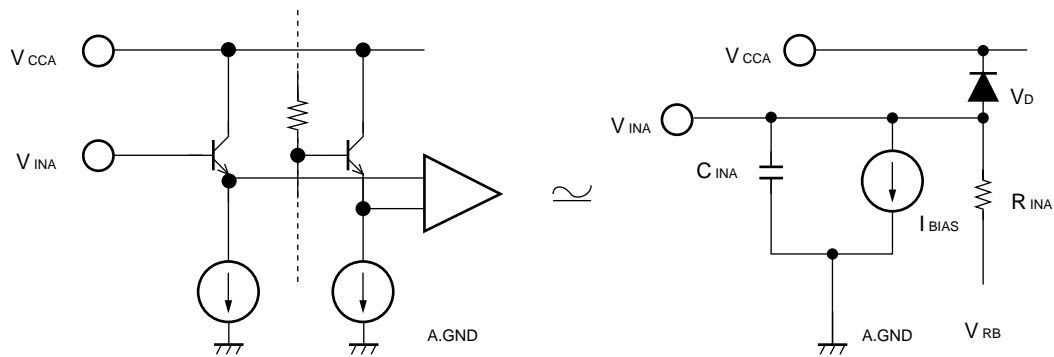

Figure 2 Analog Input Equivalent Circuit



X255 Circuits

C_{INA} : Non-linear Emitter-follower Junction Capacitance

R_{INA} : Linear Resistance Model for Input Current Transition by Comparator Switching:
Infinite value for $V_{IN} < V_{RB}$ or when CLK = High

V_{RB} : Voltage at V_{RB} terminal

I_{BIAS} : Constant Input Bias Current

V_D : The base-collector junction diode of emitter-follower transistor.

Figure 3 Digital Input Equivalent

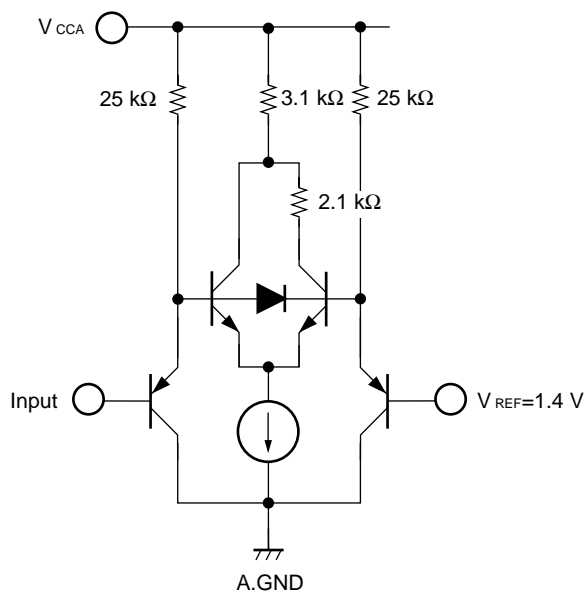
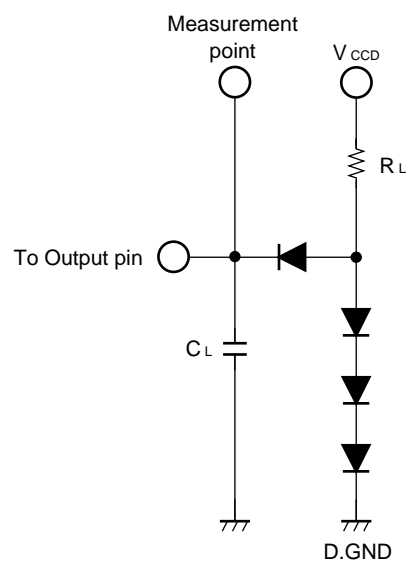

Figure 4 Load Circuit for Output Buffer



Note $R_L = 2 \text{ k}\Omega$

$C_L = 15 \text{ pF}$ including scope and jig capacitance

Diodes: IN3064 or equivalent

Figure 5 Output Code

($V_{CC}=5.0\text{ V}$, $V_{RT}\approx 5.0\text{ V}$, $V_{RB}\approx 3.0\text{ V}$)

Step	Analog Input Voltage	OUTPUT VOLTAGE(V)
0	2.960 V	00000000
1	2.968 V	00000001
⋮	⋮	⋮
127	3.976 V	01111111
128	3.984 V	10000000
129	3.992 V	10000001
⋮	⋮	⋮
245	4.992 V	11111110
255	5.000 V	11111111

Note : Adjust $V_{ZT}=2.964\text{ V}$ and $V_{FT}=4.996\text{ V}$ with V_{RT} and V_{RB} . The Analog Input Voltage are the center values of each step.

Figure 6 Ideal Conversion Characteristics

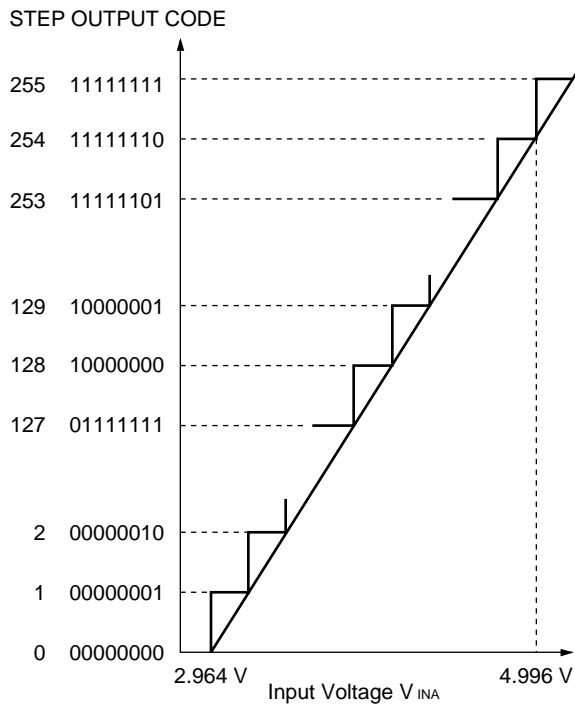
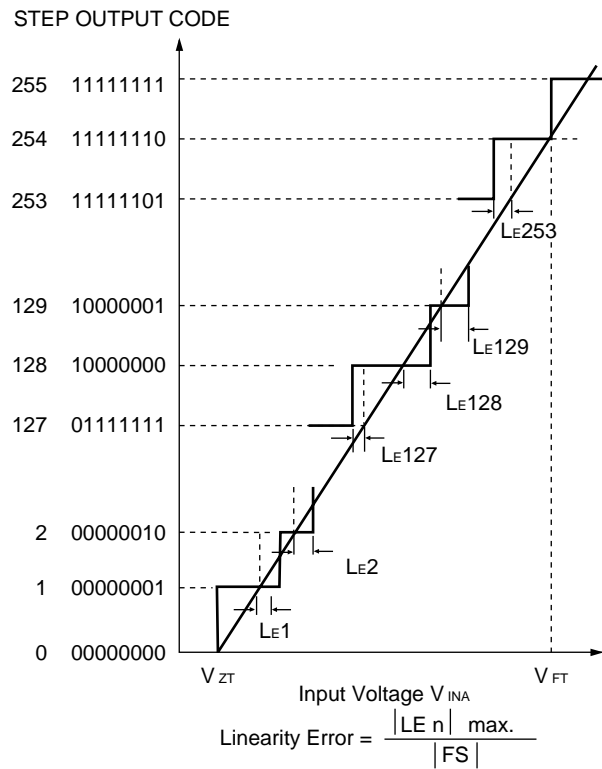
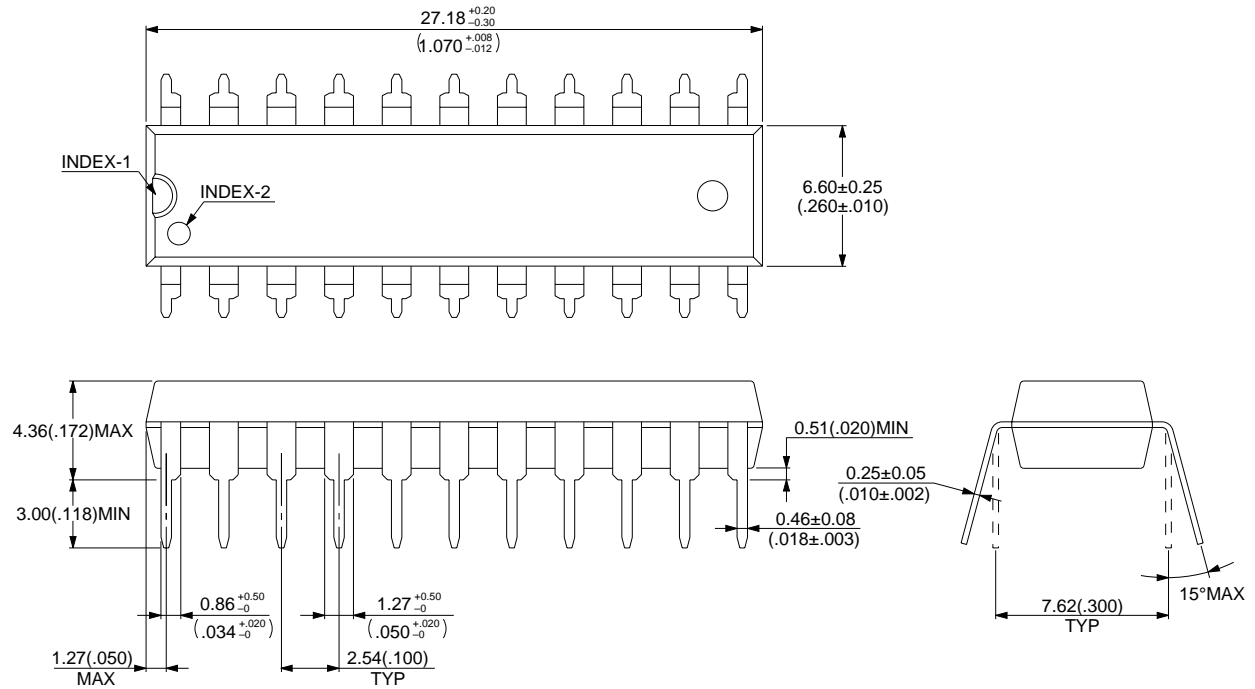

Figure 7 Actual Conversion Characteristics



■ PACKAGE DIMENSION

Plastic DIP, 22 pin
(DIP-22P-M04)



© 1994 FUJITSU LIMITED D22008S-4C-3

Dimensions in mm (inch)

FUJITSU LIMITED

For further information please contact:

Japan

FUJITSU LIMITED
Corporate Global Business Support Division
Electronic Devices
KAWASAKI PLANT, 4-1-1, Kamikodanaka
Nakahara-ku, Kawasaki-shi
Kanagawa 211-88, Japan
Tel: (044) 754-3753
Fax: (044) 754-3329

North and South America

FUJITSU MICROELECTRONICS, INC.
Semiconductor Division
3545 North First Street
San Jose, CA 95134-1804, U.S.A.
Tel: (408) 922-9000
Fax: (408) 432-9044/9045

Europe

FUJITSU MIKROELEKTRONIK GmbH
Am Siebenstein 6-10
63303 Dreieich-Buchsschlag
Germany
Tel: (06103) 690-0
Fax: (06103) 690-122

Asia Pacific

FUJITSU MICROELECTRONICS ASIA PTE. LIMITED
No. 51 Bras Basah Road,
Plaza By The Park,
#06-04 to #06-07
Singapore 189554
Tel: 336-1600
Fax: 336-1609

All Rights Reserved.

Circuit diagrams utilizing Fujitsu products are included as a means of illustrating typical semiconductor applications. Complete information sufficient for construction purposes is not necessarily given.

The information contained in this document has been carefully checked and is believed to be reliable. However, Fujitsu assumes no responsibility for inaccuracies.

The information contained in this document does not convey any license under the copyrights, patent rights or trademarks claimed and owned by Fujitsu.

Fujitsu reserves the right to change products or specifications without notice.

No part of this publication may be copied or reproduced in any form or by any means, or transferred to any third party without prior written consent of Fujitsu.

The information contained in this document are not intended for use with equipments which require extremely high reliability such as aerospace equipments, undersea repeaters, nuclear control systems or medical equipments for life support.