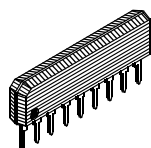
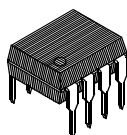
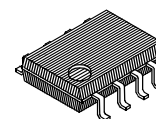

LINEAR IC**DUAL OPERATIONAL AMPLIFIER****MB47358****DUAL OPERATIONAL AMPLIFIER
OPERATES A SINGLE OR DUAL POWER SUPPLY**

The Fujitsu MB47358 is designed for a general purpose dual operational amplifier with internal frequency compensation and to operate from a single power supply or dual power supplies. The MB47358 is suitable for audio with the fast slew rate and with the reduction of cross-over distortion. The MB47358 fits an application of microcomputer because of its wide output voltage range. The MB47358 is compatible with LM358.

■ FEATURES

- Not required compensation
- Wide power supply voltage range
 - Single power supply: 3 V to 30 V
 - Dual power supplies: ± 1.5 V to ± 15 V
- Wide output voltage range
- No cross-over distortion
- Fast slew rate -2 V/ μ s typ.

■ PACKAGES**PLASTIC PACKAGE
SIP-9P-M01****PLASTIC PACKAGE
DIP-8P-M01****PLASTIC PACKAGE
FPT-8P-M01**

This device contains circuitry to protect the inputs against damage due to high static voltages or electric fields. However, it is advised that normal precautions be taken to avoid application of any voltage higher than maximum rated voltages to this high impedance circuit.

MB47358

■ ABSOLUTE MAXIMUM RATINGS (see NOTE)

($T_A = 25^\circ\text{C}$)

Rating	Symbol	Value	Unit
Power Supply Voltage	V_{CC}	36	V
Differential Input Voltage	V_{ID}	36	V
Common-mode Input Voltage	V_{ICM}	-0.3 to +36	V
Power Dissipation	P_D	350 ($T_A \leq 55^\circ\text{C}$)	mW
Operating Temperature	T_A	-20 to +75	$^\circ\text{C}$
Storage Temperature	T_{STG}	-55 to +125	$^\circ\text{C}$

NOTE: Permanent device damage may occur if the above Absolute Maximum Ratings are exceeded. Functional operation should be restricted to the conditions as detailed in the operational sections of this data sheet. Exposure to absolute maximum rating conditions for extended periods may affect device reliability.

■ PIN ASSIGNMENT

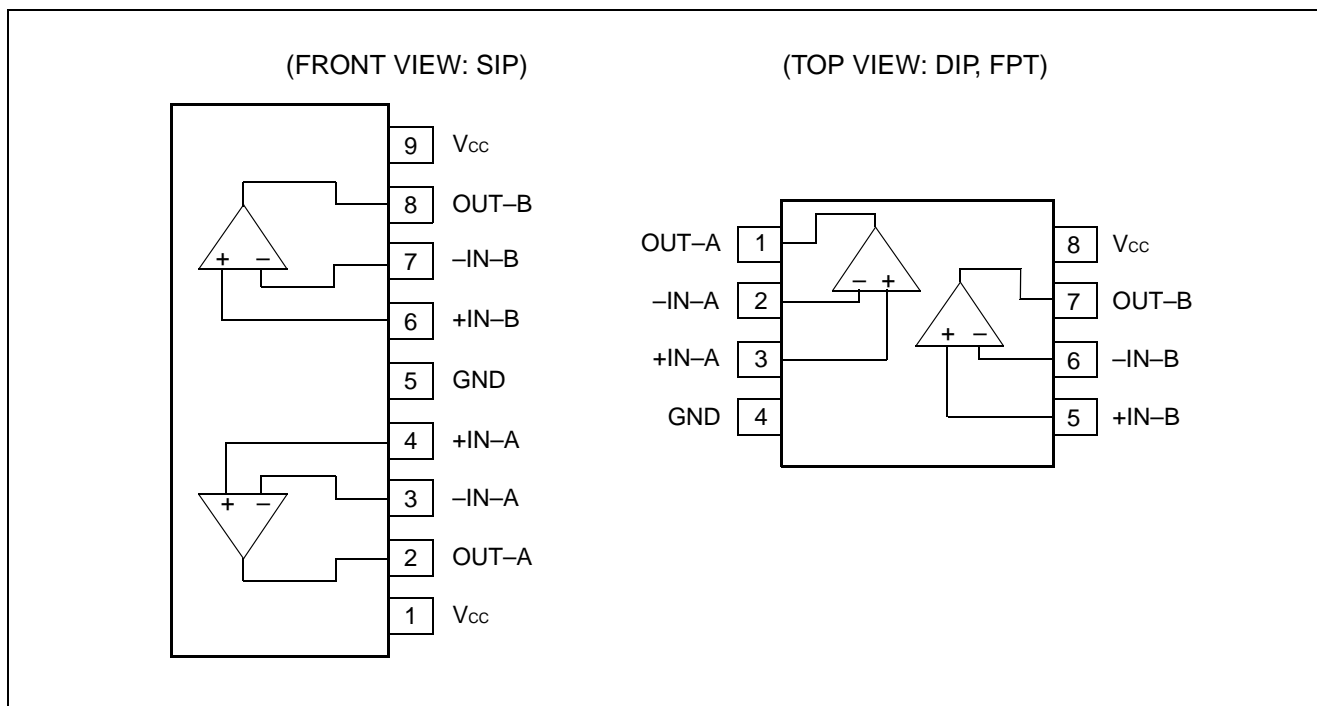
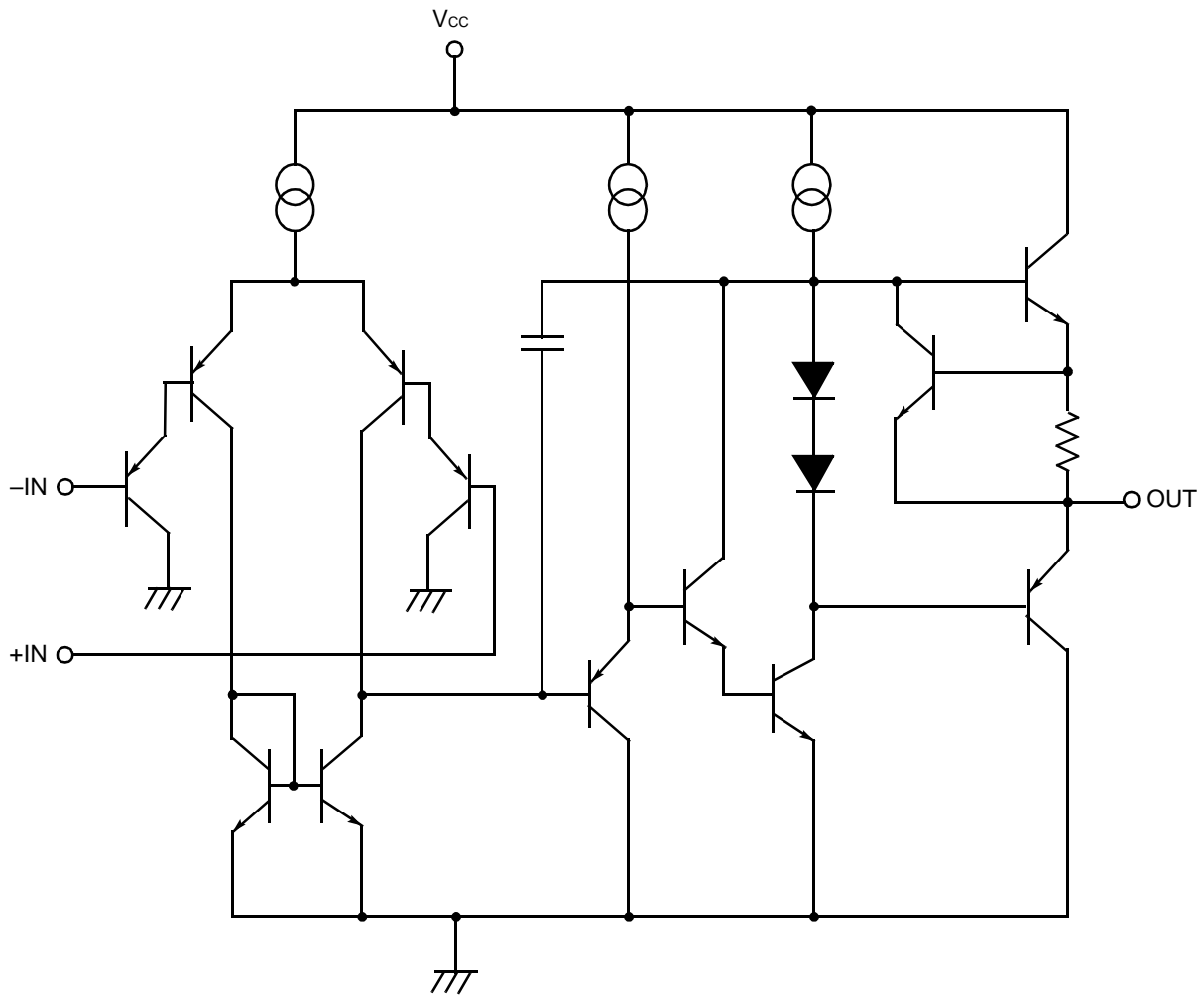

Fig. 1 — MB47358 EQUIVALENT CIRCUIT



MB47358

■ RECOMMENDED OPERATING CONDITIONS

Parameter	Symbol	Value	Unit
Power Supply Voltage	V_{CC}	3 to 30	V
		± 1.5 to ± 15	
Operating Temperature	T_A	-20 to +75	$^{\circ}\text{C}$

■ RECOMMENDED OPERATING CONDITIONS

($T_A = 25^{\circ}\text{C}$, $V_{CC} = +5\text{ V}$)

Parameter	Symbol	Condition	Value			Unit
			Min.	Typ.	Max.	
Input Offset Voltage	V_{IO}	—	—	2	7	mV
Input Offset Current	I_{IO}	—	—	5	50	nA
Input Bias Current	I_{I}^*	—	—	45	250	nA
Power Supply Current	I_{CC}	$R_L = \infty$, $V_{CC} = 5\text{ V}$	—	2.0	3.0	mA
Common-mode Input Voltage	V_{ICM}	—	0	—	$V_{CC} - 1.5$	V
Voltage Gain	A_V	$R_L \geq K\ 2\ \text{k}\Omega$	25	100	—	V/mV
Common-mode Rejection Ratio	CMRR	—	65	85	—	dB
Power Supply Voltage Rejection Ratio	SVRR	—	65	100	—	dB
Output Voltage	V_{OH}	$R_L = 2\ \text{k}\Omega$	3.5	4.1	—	V
		$R_L = 10\ \text{k}\Omega$	4.0	4.2	0	V
	V_{OL}	$I_{SINK} \leq 60\ \mu\text{A}$	—	0.2	0.4	V
		$I_{SINK} \leq 2\ \text{mA}$	—	0.8	1.5	V
Maximum Output Voltage	V_{OM}	$R_L \geq 10\ \text{k}\Omega$, $V_{CC} = \pm 15\text{ V}$	± 12	± 14	—	V
		$R_L = 2\ \text{k}\Omega$, $V_{CC} = \pm 15\text{ V}$	± 10	—	—	V
Output Current	I_{SOURCE}	$V_{IN+} = 1\text{ V}$, $V_{IN-} = 0\text{ V}$, $V_{CC} = 15\text{ V}$	20	40	—	mA
	I_{SINK}	$V_{IN+} = 0\text{ V}$, $V_{IN-} = 1\text{ V}$, $V_{CC} = 15\text{ V}$	10	20	—	mA
		$V_{IN+} = 0\text{ V}$, $V_{IN-} = 1\text{ V}$, $V_O = 0.4\text{ V}$	60	150	—	μA
Channel Separation	CS	$f = 1\ \text{kHz}$	—	120	—	dB
Slew Rate	SR	$R_L = 2\ \text{k}\Omega$	—	2	—	V/ μs

Note: A direction of the input bias current flows from IC because first input transistor consists of PNP.

■ TYPICAL CHARACTERISTICS CURVES

Fig. 2 – POWER SUPPLY VOLTAGE vs. POWER SUPPLY CURRENT

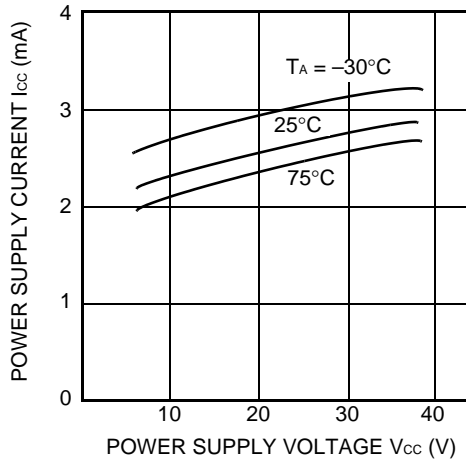

Fig. 3 – OUTPUT CURRENT vs. OUTPUT VOLTAGE

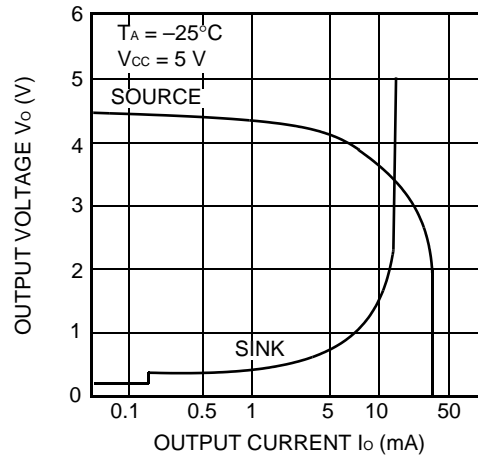

Fig. 4 – TEMPERATURE vs. INPUT BIAS CURRENT

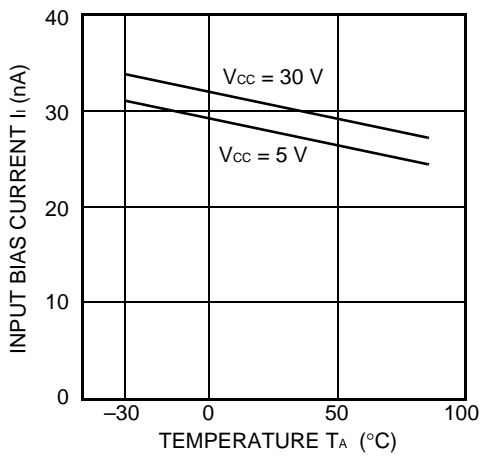

Fig. 5 – FREQUENCY vs. OUTPUT VOLTAGE

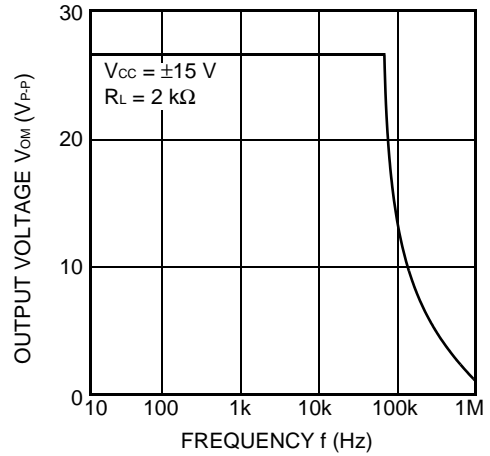
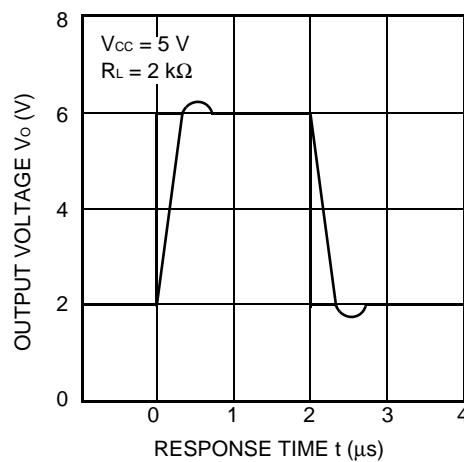

Fig. 6 – PULSE RESPONSE



MB47358

■ PACKAGE DIMENSIONS

9 pin, Plastic SIP
(SIP-9P-M01)

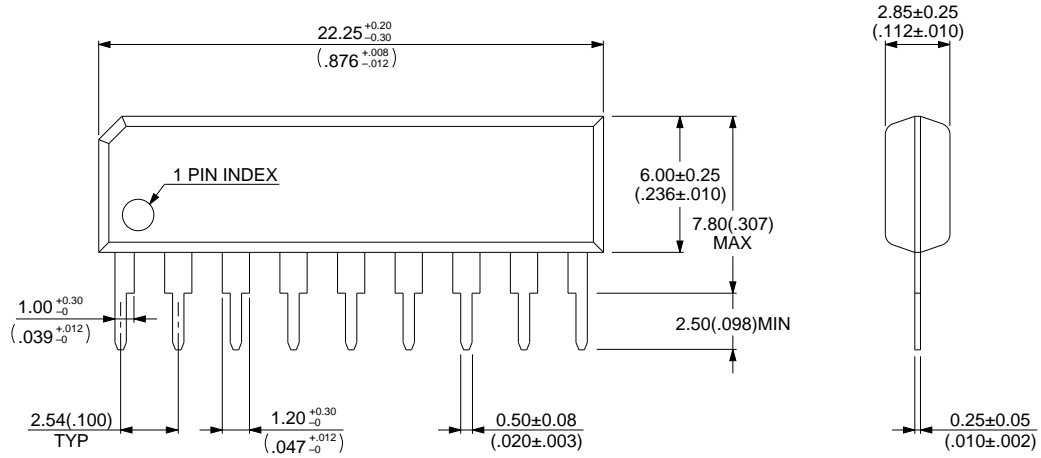

© 1994 FUJITSU LIMITED S09002S-3C-3

Dimensions in mm(inches).

■ PACKAGE DIMENSIONS (Continued)

8 pin, Plastic DIP
(DIP-8P-M01)

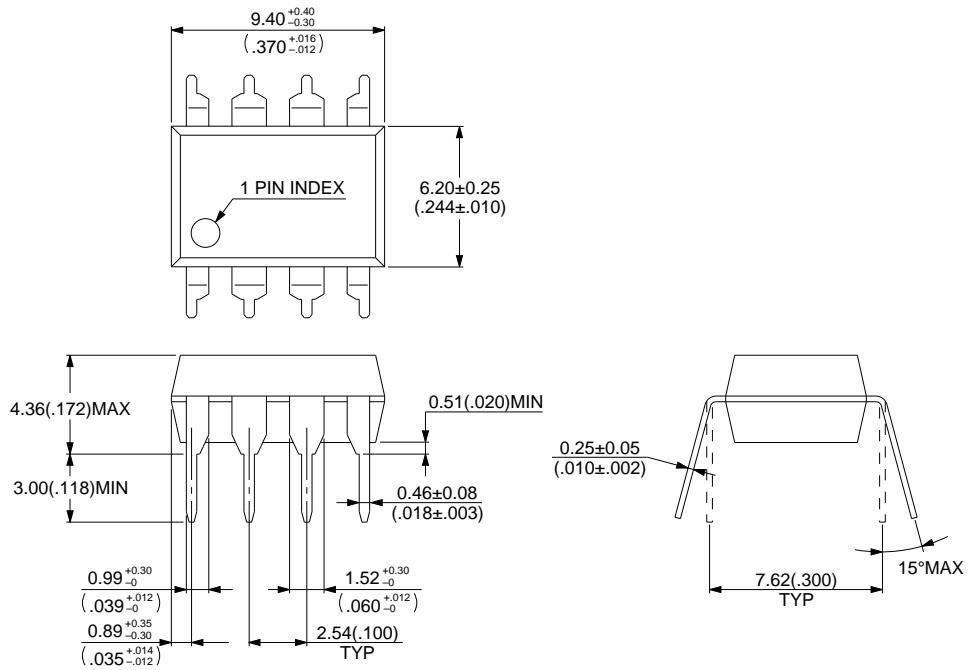

© 1994 FUJITSU LIMITED D08006S-2C-3

Dimensions in mm(inches).

MB47358

■ PACKAGE DIMENSIONS (Continued)

8 pin, Plastic SOP
(FPT-8P-M01)

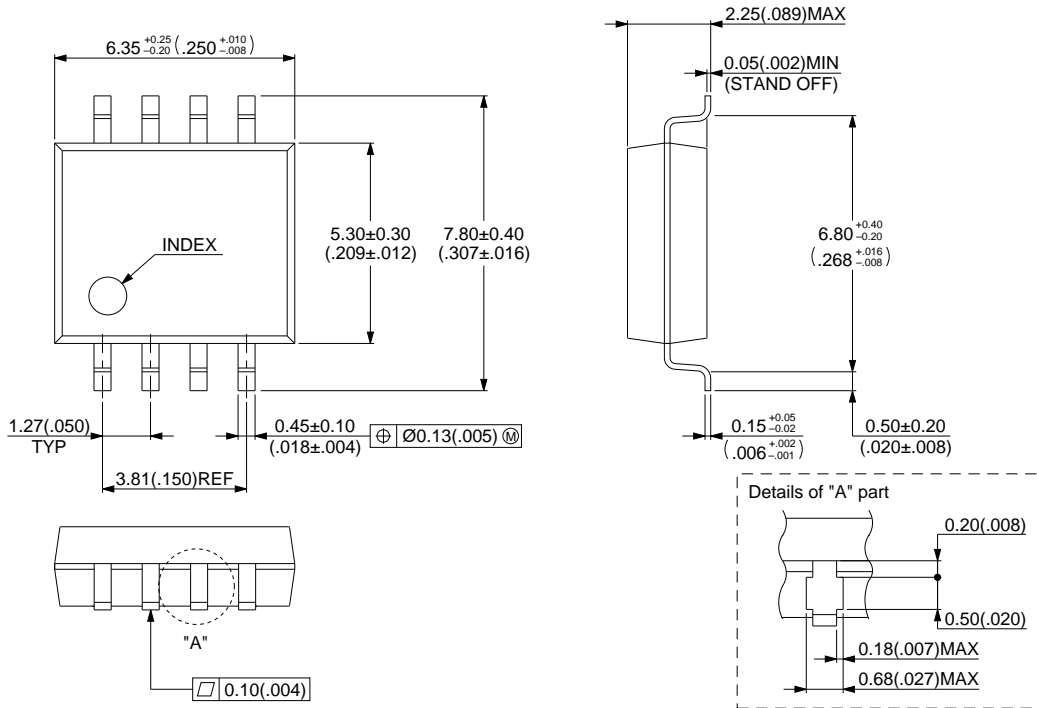

© 1994 FUJITSU LIMITED F08002S-4C-4

Dimensions in mm(inches).

FUJITSU LIMITED

For further information please contact:

Japan

FUJITSU LIMITED
Corporate Global Business Support Division
Electronic Devices
KAWASAKI PLANT, 4-1-1, Kamikodanaka
Nakahara-ku, Kawasaki-shi
Kanagawa 211-88, Japan
Tel: (044) 754-3763
Fax: (044) 754-3329

North and South America

FUJITSU MICROELECTRONICS, INC.
Semiconductor Division
3545 North First Street
San Jose, CA 95134-1804, U.S.A.
Tel: (408) 922-9000
Fax: (408) 432-9044/9045

Europe

FUJITSU MIKROELEKTRONIK GmbH
Am Siebenstein 6-10
63303 Dreieich-Buchsschlag
Germany
Tel: (06103) 690-0
Fax: (06103) 690-122

Asia Pacific

FUJITSU MICROELECTRONICS ASIA PTE. LIMITED
#05-08, 151 Lorong Chuan
New Tech Park
Singapore 556741
Tel: (65) 281-0770
Fax: (65) 281-0220

All Rights Reserved.

The contents of this document are subject to change without notice. Customers are advised to consult with FUJITSU sales representatives before ordering.

The information and circuit diagrams in this document presented as examples of semiconductor device applications, and are not intended to be incorporated in devices for actual use. Also, FUJITSU is unable to assume responsibility for infringement of any patent rights or other rights of third parties arising from the use of this information or circuit diagrams.

FUJITSU semiconductor devices are intended for use in standard applications (computers, office automation and other office equipment, industrial, communications, and measurement equipment, personal or household devices, etc.).

CAUTION:

Customers considering the use of our products in special applications where failure or abnormal operation may directly affect human lives or cause physical injury or property damage, or where extremely high levels of reliability are demanded (such as aerospace systems, atomic energy controls, sea floor repeaters, vehicle operating controls, medical devices for life support, etc.) are requested to consult with FUJITSU sales representatives before such use. The company will not be responsible for damages arising from such use without prior approval.

Any semiconductor devices have inherently a certain rate of failure. You must protect against injury, damage or loss from such failures by incorporating safety design measures into your facility and equipment such as redundancy, fire protection, and prevention of over-current levels and other abnormal operating conditions.

If any products described in this document represent goods or technologies subject to certain restrictions on export under the Foreign Exchange and Foreign Trade Control Law of Japan, the prior authorization by Japanese government should be required for export of those products from Japan.