

MCP (Multi-Chip Package) FLASH MEMORY & SRAM CMOS

16M (×16) FLASH MEMORY & 2M (× 8) STATIC RAM

MB84VA2102-10/MB84VA2103-10

■ FEATURES

- Power supply voltage of 2.7 to 3.6 V
- High performance
100 ns maximum access time
- Operating Temperature
-20 to +85°C

— FLASH MEMORY

- Minimum 100,000 write/erase cycles
- Sector erase architecture
One 8 K word, two 4 K words, one 16 K word, and thirty one 32 K words.
Any combination of sectors can be concurrently erased. Also supports full chip erase.
- Boot Code Sector Architecture
MB84VA2102: Top sector
MB84VA2103: Bottom sector
- Embedded Erase™ Algorithms
Automatically pre-programs and erases the chip or any sector
- Embedded Program™ Algorithms
Automatically writes and verifies data at specified address
- Data Polling and Toggle Bit feature for detection of program or erase cycle completion
- Ready-Busy output (RY/BY)
Hardware method for detection of program or erase cycle completion
- Automatic sleep mode
When addresses remain stable, automatically switch themselves to low power mode.
- Low V_{cc} write inhibit ≤ 2.5 V
- Erase Suspend/Resume
Suspends the erase operation to allow a read in another sector within the same device
Please refer to "MBM29LV160T/B" data sheet in detailed function

— SRAM

- Power dissipation
Operating : 35 mA max.
Standby : 50 μA max.
- Power down features using $\overline{CE1}$ s and CE2s
- Data retention supply voltage: 2.0 V to 3.6 V

MB84VA2102-10/MB84VA2103-10

■ BLOCK DIAGRAM

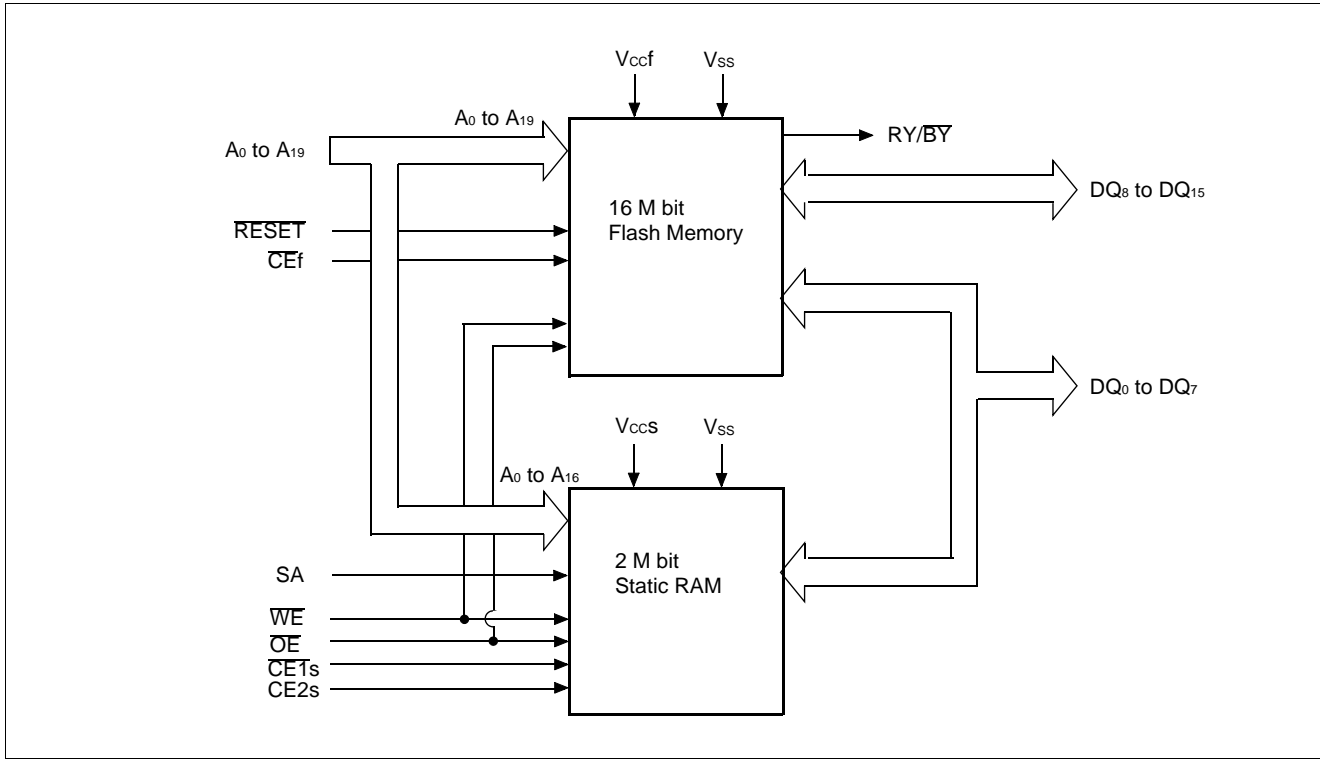

■ EXAMPLE OF CONNECTION WITH CHIPSET

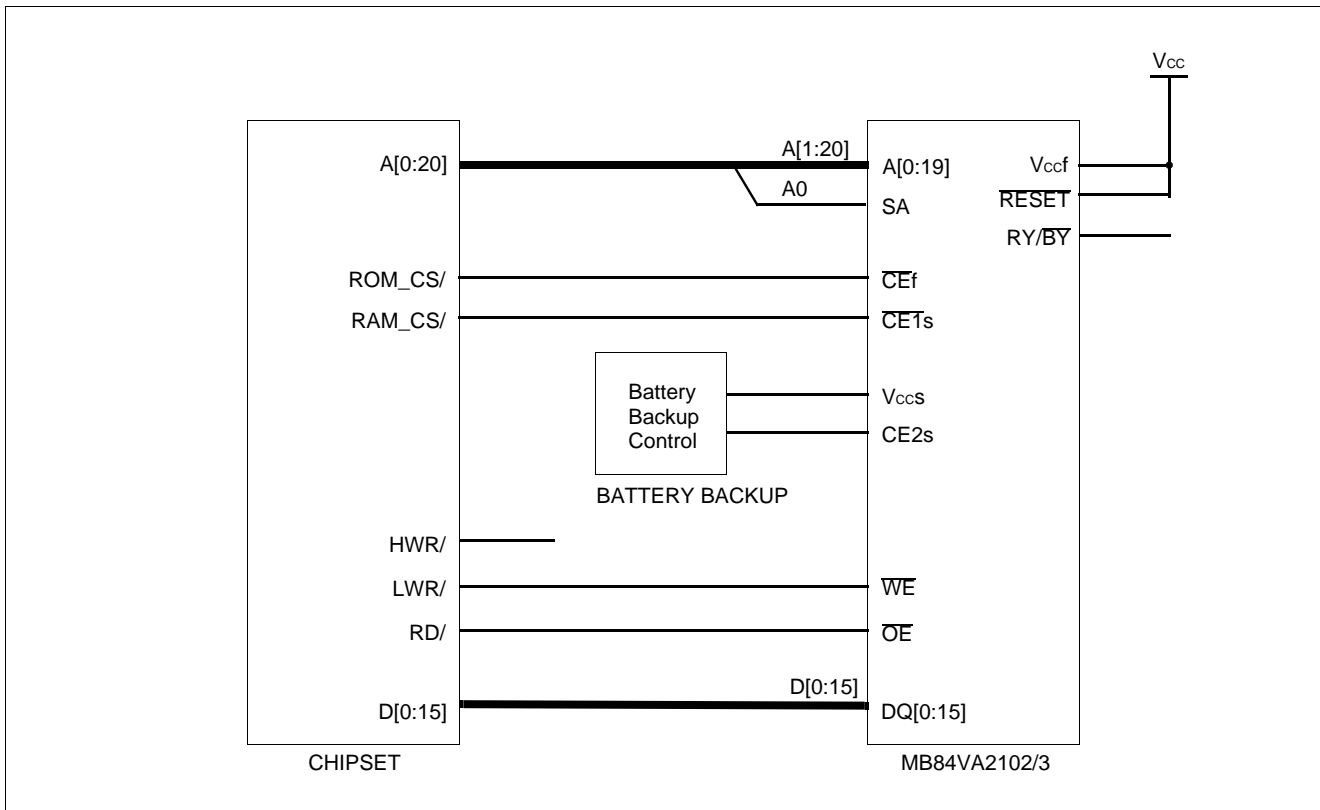

■ PIN ASSIGNMENTS

(Top View)

	A	B	C	D	E	F	G	H
6	$\overline{CE}1s$	V _{SS}	DQ ₁	A ₁	A ₂	A ₄	CE2s	A ₉
5	A ₁₀	DQ ₅	DQ ₂	A ₀	A ₃	A ₇	RY/ \overline{BY}	A ₁₄
4	\overline{OE}	DQ ₇	DQ ₄	DQ ₀	A ₆	A ₁₈	RESET	A ₁₅
3	A ₁₁	A ₈	A ₅	DQ ₈	DQ ₃	DQ ₁₂	A ₁₂	A ₁₉
2	A ₁₃	A ₁₇	SA*	$\overline{CE}f$	DQ ₁₀	V _{ccf}	DQ ₆	DQ _{15/A-1}
1	\overline{WE}	V _{CCS}	A ₁₆	V _{SS}	DQ ₉	DQ ₁₁	DQ ₁₃	DQ ₁₄

*: A₁₇ for SRAM

Table 1 Pin Configuration

Pin	Function	Input/ Output
A ₀ to A ₁₆	Address Inputs (Common)	I
A ₁₇ to A ₁₉	Address Input (Flash)	I
SA	Address Input (SRAM)	I
DQ ₀ to DQ ₇	Data Inputs/Outputs (Common)	I/O
DQ ₈ to DQ ₁₅	Data Inputs/Outputs (Flash)	I/O
$\overline{CE}f$	Chip Enable (Flash)	I
$\overline{CE}1s$	Chip Enable (SRAM)	I
CE2s	Chip Enable (SRAM)	I
\overline{OE}	Output Enable (Common)	I
\overline{WE}	Write Enable (Common)	I
RY/ \overline{BY}	Ready/Busy Outputs (Flash)	O
RESET	Hardware Reset Pin/Sector Protection Unlock (Flash)	I
N.C.	No Internal Connection	—
V _{SS}	Device Ground (Common)	Power
V _{ccf}	Device Power Supply (Flash)	Power
V _{CCS}	Device Power Supply (SRAM)	Power

MB84VA2102-10/MB84VA2103-10

■ PRODUCT LINE UP

		Flash Memory	SRAM
Ordering Part No.	$V_{CC} = 3.0\text{ V} \begin{matrix} +0.6\text{ V} \\ -0.3\text{ V} \end{matrix}$	MB84VA2102-10/MB84VA2103-10	
Max. Address Access Time (ns)		100	100
Max. \overline{CE} Access Time (ns)		100	100
Max. \overline{OE} Access Time (ns)		40	50

■ BUS OPERATIONS

Table 2 User Bus Operations

Operation (1), (3)	\overline{CEf}	$\overline{CE1s}$	$CE2s$	\overline{OE}	\overline{WE}	DQ ₀ to DQ ₇	DQ ₈ to DQ ₁₅	RESET
Full Standby	H	H	X	X	X	HIGH-Z	HIGH-Z	H
		X	L					
Output Disable	X	X	X	H	H	HIGH-Z	HIGH-Z	H
Read from Flash (2)	L	H	X	L	H	D _{OUT}	D _{OUT}	H
		X	L					
Write to Flash	L	H	X	H	L	D _{IN}	D _{IN}	H
		X	L					
Read from SRAM	H	L	H	L	H	D _{OUT}	HIGH-Z	H
Write to SRAM	H	L	H	X	L	D _{IN}	HIGH-Z	H
Flash Hardware Reset	X	H	X	X	X	HIGH-Z	HIGH-Z	L
		X	L					

Legend: L = V_{IL}, H = V_{IH}, X = V_{IL} or V_{IH}. See DC Characteristics for voltage levels.

- Notes:**
1. Other operations except for indicated this column are inhibited.
 2. \overline{WE} can be V_{IL} if \overline{OE} is V_{IL}, \overline{OE} at V_{IH} initiates the write operations.
 3. Do not apply $\overline{CEf} = V_{IL}$, $\overline{CE1s} = V_{IL}$ and $CE2s = V_{IH}$ at a time.

MB84VA2102-10/MB84VA2103-10

■ FLEXIBLE SECTOR-ERASE ARCHITECTURE on FLASH MEMORY

- One 8 K word, two 4 K words, one 16 K word, and thirty one 32 K words.
- Individual-sector, multiple-sector, or bulk-erase capability.

Sector	Sector Size	Address Range
SA0	32K Words	00000H to 07FFFFH
SA1	32K Words	08000H to 0FFFFH
SA2	32K Words	10000H to 17FFFFH
SA3	32K Words	18000H to 1FFFFH
SA4	32K Words	20000H to 27FFFFH
SA5	32K Words	28000H to 2FFFFH
SA6	32K Words	30000H to 37FFFFH
SA7	32K Words	38000H to 3FFFFH
SA8	32K Words	40000H to 47FFFFH
SA9	32K Words	48000H to 4FFFFH
SA10	32K Words	50000H to 57FFFFH
SA11	32K Words	58000H to 5FFFFH
SA12	32K Words	60000H to 67FFFFH
SA13	32K Words	68000H to 6FFFFH
SA14	32K Words	70000H to 77FFFFH
SA15	32K Words	78000H to 7FFFFH
SA16	32K Words	80000H to 87FFFFH
SA17	32K Words	88000H to 8FFFFH
SA18	32K Words	90000H to 97FFFFH
SA19	32K Words	98000H to 9FFFFH
SA20	32K Words	A0000H to A7FFFFH
SA21	32K Words	A8000H to AFFFFH
SA22	32K Words	B0000H to B7FFFFH
SA23	32K Words	B8000H to BFFFFH
SA24	32K Words	C0000H to C7FFFFH
SA25	32K Words	C8000H to CFFFFH
SA26	32K Words	D0000H to D7FFFFH
SA27	32K Words	D8000H to DFFFFH
SA28	32K Words	E0000H to E7FFFFH
SA29	32K Words	E8000H to EFFFFH
SA30	32K Words	F0000H to F7FFFFH
SA31	16K Words	F8000H to FBFFFFH
SA32	4K Words	FC000H to FCFFFFH
SA33	4K Words	FD000H to FDFFFFH
SA34	8K Words	FE000H to FFFFFH

Sector	Sector Size	Address Range
SA0	8K Words	00000H to 01FFFFH
SA1	4K Words	02000H to 02FFFFH
SA2	4K Words	03000H to 03FFFFH
SA3	16K Words	04000H to 07FFFFH
SA4	32K Words	08000H to 0FFFFH
SA5	32K Words	10000H to 17FFFFH
SA6	32K Words	18000H to 1FFFFH
SA7	32K Words	20000H to 27FFFFH
SA8	32K Words	28000H to 2FFFFH
SA9	32K Words	30000H to 37FFFFH
SA10	32K Words	38000H to 3FFFFH
SA11	32K Words	40000H to 47FFFFH
SA12	32K Words	48000H to 4FFFFH
SA13	32K Words	50000H to 57FFFFH
SA14	32K Words	58000H to 5FFFFH
SA15	32K Words	60000H to 67FFFFH
SA16	32K Words	68000H to 6FFFFH
SA17	32K Words	70000H to 77FFFFH
SA18	32K Words	78000H to 7FFFFH
SA19	32K Words	80000H to 87FFFFH
SA20	32K Words	88000H to 8FFFFH
SA21	32K Words	90000H to 97FFFFH
SA22	32K Words	98000H to 9FFFFH
SA23	32K Words	A0000H to A7FFFFH
SA24	32K Words	A8000H to AFFFFH
SA25	32K Words	B0000H to B7FFFFH
SA26	32K Words	B8000H to BFFFFH
SA27	32K Words	C0000H to C7FFFFH
SA28	32K Words	C8000H to CFFFFH
SA29	32K Words	D0000H to D7FFFFH
SA30	32K Words	D8000H to DFFFFH
SA31	32K Words	E0000H to E7FFFFH
SA32	32K Words	E8000H to EFFFFH
SA33	32K Words	F0000H to F7FFFFH
SA34	32K Words	F8000H to FFFFFH

MB84VA2102 Sector Architecture

MB84VA2103 Sector Architecture

MB84VA2102-10/MB84VA2103-10

Table 3 Sector Address Tables (MB84VA2102)

Sector Address	A ₁₉	A ₁₈	A ₁₇	A ₁₆	A ₁₅	A ₁₄	A ₁₃	A ₁₂	Address Range
SA0	0	0	0	0	0	X	X	X	00000H to 07FFFFH
SA1	0	0	0	0	1	X	X	X	08000H to 0FFFFH
SA2	0	0	0	1	0	X	X	X	10000H to 17FFFFH
SA3	0	0	0	1	1	X	X	X	18000H to 1FFFFH
SA4	0	0	1	0	0	X	X	X	20000H to 27FFFFH
SA5	0	0	1	0	1	X	X	X	28000H to 2FFFFH
SA6	0	0	1	1	0	X	X	X	30000H to 37FFFFH
SA7	0	0	1	1	1	X	X	X	38000H to 3FFFFH
SA8	0	1	0	0	0	X	X	X	40000H to 47FFFFH
SA9	0	1	0	0	1	X	X	X	48000H to 4FFFFH
SA10	0	1	0	1	0	X	X	X	50000H to 57FFFFH
SA11	0	1	0	1	1	X	X	X	58000H to 5FFFFH
SA12	0	1	1	0	0	X	X	X	60000H to 67FFFFH
SA13	0	1	1	0	1	X	X	X	68000H to 6FFFFH
SA14	0	1	1	1	0	X	X	X	70000H to 77FFFFH
SA15	0	1	1	1	1	X	X	X	78000H to 7FFFFH
SA16	1	0	0	0	0	X	X	X	80000H to 87FFFFH
SA17	1	0	0	0	1	X	X	X	88000H to 8FFFFH
SA18	1	0	0	1	0	X	X	X	90000H to 97FFFFH
SA19	1	0	0	1	1	X	X	X	98000H to 9FFFFH
SA20	1	0	1	0	0	X	X	X	A0000H to A7FFFFH
SA21	1	0	1	0	1	X	X	X	A8000H to AFFFFH
SA22	1	0	1	1	0	X	X	X	B0000H to B7FFFFH
SA23	1	0	1	1	1	X	X	X	B8000H to BFFFFH
SA24	1	1	0	0	0	X	X	X	C0000H to C7FFFFH
SA25	1	1	0	0	1	X	X	X	C8000H to CFFFFH
SA26	1	1	0	1	0	X	X	X	D0000H to D7FFFFH
SA27	1	1	0	1	1	X	X	X	D8000H to DFFFFH
SA28	1	1	1	0	0	X	X	X	E0000H to E7FFFFH
SA29	1	1	1	0	1	X	X	X	E8000H to EFFFFH
SA30	1	1	1	1	0	X	X	X	F0000H to F7FFFFH
SA31	1	1	1	1	1	0	X	X	F8000H to FBFFFFH
SA32	1	1	1	1	1	1	0	0	FC000H to FCFFFFH
SA33	1	1	1	1	1	1	0	1	FD000H to FDFFFFH
SA34	1	1	1	1	1	1	1	X	FE000H to FFFFFH

MB84VA2102-10/MB84VA2103-10

Table 4 Sector Address Tables (MB84VA2103)

Sector Address	A ₁₉	A ₁₈	A ₁₇	A ₁₆	A ₁₅	A ₁₄	A ₁₃	A ₁₂	Address Range
SA0	0	0	0	0	0	0	0	X	00000H to 01FFFFH
SA1	0	0	0	0	0	0	1	0	02000H to 02FFFFH
SA2	0	0	0	0	0	0	1	1	03000H to 03FFFFH
SA3	0	0	0	0	0	1	0	X	04000H to 07FFFFH
SA4	0	0	0	0	1	X	X	X	08000H to 0FFFFH
SA5	0	0	0	1	0	X	X	X	10000H to 17FFFFH
SA6	0	0	0	1	1	X	X	X	18000H to 1FFFFH
SA7	0	0	1	0	0	X	X	X	20000H to 27FFFFH
SA8	0	0	1	0	1	X	X	X	28000H to 2FFFFH
SA9	0	0	1	1	0	X	X	X	30000H to 37FFFFH
SA10	0	0	1	1	1	X	X	X	38000H to 3FFFFH
SA11	0	1	0	0	0	X	X	X	40000H to 47FFFFH
SA12	0	1	0	0	1	X	X	X	48000H to 4FFFFH
SA13	0	1	0	1	0	X	X	X	50000H to 57FFFFH
SA14	0	1	0	1	1	X	X	X	58000H to 5FFFFH
SA15	0	1	1	0	0	X	X	X	60000H to 67FFFFH
SA16	0	1	1	0	1	X	X	X	68000H to 6FFFFH
SA17	0	1	1	1	0	X	X	X	70000H to 77FFFFH
SA18	0	1	1	1	1	X	X	X	78000H to 7FFFFH
SA19	1	0	0	0	0	X	X	X	80000H to 87FFFFH
SA20	1	0	0	0	1	X	X	X	88000H to 8FFFFH
SA21	1	0	0	1	0	X	X	X	90000H to 97FFFFH
SA22	1	0	0	1	1	X	X	X	98000H to 9FFFFH
SA23	1	0	1	0	0	X	X	X	A0000H to A7FFFFH
SA24	1	0	1	0	1	X	X	X	A8000H to 8FFFFH
SA25	1	0	1	1	0	X	X	X	B0000H to B7FFFFH
SA26	1	0	1	1	1	X	X	X	B8000H to BFFFFH
SA27	1	1	0	0	0	X	X	X	C0000H to C7FFFFH
SA28	1	1	0	0	1	X	X	X	C8000H to CFFFFH
SA29	1	1	0	1	0	X	X	X	D0000H to D7FFFFH
SA30	1	1	0	1	1	X	X	X	D8000H to DFFFFH
SA31	1	1	1	0	0	X	X	X	E0000H to E7FFFFH
SA32	1	1	1	0	1	X	X	X	E8000H to EFFFFH
SA33	1	1	1	1	0	X	X	X	F0000H to F7FFFFH
SA34	1	1	1	1	1	X	X	X	F8000H to FFFFFH

MB84VA2102-10/MB84VA2103-10

Table 5.1 Flash Memory Autoselect Codes

Type		A ₆	A ₁	A ₀	Code (HEX)
Manufacturer's Code		V _{IL}	V _{IL}	V _{IL}	04H
Device Code	MB84VA2102	V _{IL}	V _{IL}	V _{IH}	22C4H
	MB84VA2103	V _{IL}	V _{IL}	V _{IH}	2249H

Table 5.2 Expanded Autoselect Code Table

Type		Code	DQ ₁₅	DQ ₁₄	DQ ₁₃	DQ ₁₂	DQ ₁₁	DQ ₁₀	DQ ₉	DQ ₈	DQ ₇	DQ ₆	DQ ₅	DQ ₄	DQ ₃	DQ ₂	DQ ₁	DQ ₀
Manufacturer's Code		04H	0	0	0	0	0	0	0	0	0	0	0	0	0	1	0	0
Device Code	MB84VA2102	22C4H	0	0	1	0	0	0	1	0	1	1	0	0	0	1	0	0
	MB84VA2103	2249H	0	0	1	0	0	0	1	0	0	1	0	0	1	0	0	1

Table 6 Flash Memory Command Definitions

Command Sequence	Bus Write Cycles Req'd	First Bus Write Cycle		Second Bus Write Cycle		Third Bus Write Cycle		Fourth Bus Read/Write Cycle		Fifth Bus Write Cycle		Sixth Bus Write Cycle	
		Addr.	Data	Addr.	Data	Addr.	Data	Addr.	Data	Addr.	Data	Addr.	Data
Read/Reset	1	XXXH	F0H	—	—	—	—	—	—	—	—	—	—
Read/Reset	3	555H	AAH	2AAH	55H	555H	F0H	RA	RD	—	—	—	—
Autoselect	3	555H	AAH	2AAH	55H	555H	90H	—	—	—	—	—	—
Program	4	555H	AAH	2AAH	55H	555H	A0H	PA	PD	—	—	—	—
Chip Erase	6	555H	AAH	2AAH	55H	555H	80H	555H	AAH	2AAH	55H	555H	10H
Sector Erase	6	555H	AAH	2AAH	55H	555H	80H	555H	AAH	2AAH	55H	SA	30H
Sector Erase Suspend	Erase can be suspended during sector erase with Addr. ("H" or "L"). Data (B0H)												
Sector Erase Resume	Erase can be resumed after suspend with Addr. ("H" or "L"). Data (30H)												
Set to Fast Mode	3	555H	AAH	2AAH	55H	555H	20H	—	—	—	—	—	—
Fast Program (Note)	2	XXXH	A0H	PA	PD	—	—	—	—	—	—	—	—
Reset from Fast Mode (Note)	2	XXXH	90H	XXXH	F0H	—	—	—	—	—	—	—	—
Extended Sector Protect	4	XXXH	60H	SPA	60H	SPA	40H	SPA	SD	—	—	—	—

Address bits A_{11} to $A_{20} = X = \text{"H" or "L"}$ for all address commands except for Program Address (PA) and Sector Address (SA).

Bus operations are defined in Table 2.

Both Read/Reset commands are functionally equivalent, resetting the device to the read mode.

RA =Address of the memory location to be read.

PA =Address of the memory location to be programmed. Addresses are latched on the falling edge of the write pulse.

SA =Address of the sector to be erased. The combination of A_{20} , A_{19} , A_{18} , A_{17} , A_{16} , A_{15} , A_{14} , and A_{13} will uniquely select any sector.

RD =Data read from location RA during read operation.

PD =Data to be programmed at location PA.

SPA =Sector address to be protected. Set sector address (SA) and $(A_6, A_1, A_0) = (0, 1, 0)$.

SD =Sector protection verify data. Output 01H at protected sector addresses and output 00H at unprotected sector addresses.

Note:This command is valid while Fast Mode.

MB84VA2102-10/MB84VA2103-10

■ ABSOLUTE MAXIMUM RATINGS

Storage Temperature	-55°C to +125°C
Ambient Temperature with Power Applied	-25°C to +85°C
Voltage with Respect to Ground All pins (Note)	-0.3 V to $V_{ccf} + 0.5$ V
	-0.3 V to $V_{ccs} + 0.5$ V
V_{ccf}/V_{ccs} Supply (Note)	-0.3 V to +4.6 V

Note: Minimum DC voltage on input or I/O pins are -0.5 V. During voltage transitions, inputs may negative overshoot V_{ss} to -2.0 V for periods of up to 20 ns. Maximum DC voltage on output and I/O pins are $V_{ccf} + 0.5$ V or $V_{ccs} + 0.5$ V. During voltage transitions, outputs may positive overshoot to $V_{cc} + 2.0$ V for periods of up to 20 ns.

WARNING: Semiconductor devices can be permanently damaged by application of stress (voltage, current, temperature, etc.) in excess of absolute maximum ratings. Do not exceed these ratings.

■ RECOMMENDED OPERATING RANGES

Commercial Devices	
Ambient Temperature (T_A)	-20°C to +85°C
V_{ccf}/V_{ccs} Supply Voltages.....	+2.7 V to +3.6 V

Operating ranges define those limits between which the functionality of the device is guaranteed.

WARNING: Recommended operating conditions are normal operating ranges for the semiconductor device. All the device's electrical characteristics are warranted when operated within these ranges.

Always use semiconductor devices within the recommended operating conditions. Operation outside these ranges may adversely affect reliability and could result in device failure.

No warranty is made with respect to uses, operating conditions, or combinations not represented on the data sheet. Users considering application outside the listed conditions are advised to contact their FUJITSU representative beforehand.

MB84VA2102-10/MB84VA2103-10

■ DC CHARACTERISTICS

Parameter Symbol	Parameter Description	Test Conditions		Min.	Typ.	Max.	Unit	
I _{LI}	Input Leakage Current	—		-1.0	—	+1.0	μA	
I _{LO}	Output Leakage Current	—		-1.0	—	+1.0	μA	
I _{CC1f}	Flash V _{CC} Active Current (Read)	V _{CCf} = V _{CC} Max., $\overline{CE}f = V_{IL}$ $\overline{OE} = V_{IH}$	t _{CYCLE} = 10 MHz	—	—	35	mA	
			t _{CYCLE} = 5 MHz	—	—	17		
I _{CC2f}	Flash V _{CC} Active Current (Program/Erase)	V _{CCf} = V _{CC} Max., $\overline{CE}f = V_{IL}$, $\overline{OE} = V_{IH}$		—	—	35	mA	
I _{CC1S}	SRAM V _{CC} Active Current	V _{CCS} = V _{CC} Max., $\overline{CE}1s = V_{IL}$, $\overline{CE}2s = V_{IH}$	t _{CYCLE} = 10 MHz	—	—	40	mA	
			t _{CYCLE} = 1 MHz	—	—	12	mA	
I _{CC2S}	SRAM V _{CC} Active Current	$\overline{CE}1s = 0.2\text{ V}$, $\overline{CE}2s = V_{CCS} - 0.2\text{ V}$, $\overline{WE} = V_{CCS} - 0.2\text{ V}$	t _{CYCLE} = 10 MHz	—	—	35	mA	
			t _{CYCLE} = 1 MHz	—	—	6	mA	
I _{SB1f}	Flash V _{CC} Standby Current	V _{CCf} = V _{CC} Max., $\overline{CE}f = V_{CCf} \pm 0.3\text{ V}$ RESET = V _{CCf} ± 0.3 V		—	—	5	μA	
I _{SB2f}	Flash V _{CC} Standby Current (RESET)	V _{CCf} = V _{CC} Max., RESET = V _{SS} ± 0.3 V		—	—	5	μA	
I _{SB1S}	SRAM V _{CC} Standby Current	$\overline{CE}1s = V_{IH}$ or $\overline{CE}2s = V_{IL}$		—	—	2	mA	
I _{SB2S} **	SRAM V _{CC} Standby Current	$\overline{CE}1s = V_{CC} - 0.2\text{ V}$ or $\overline{CE}2s = 0.2\text{ V}$	V _{CCS} = 3.0 V ± 10%	T _A = 25°C	—	1	2.5	μA
				T _A = -20 to +85°C	—	—	55	μA
			V _{CCS} = 3.3 V ± 0.3 V	T _A = 25°C	—	1.5	3	μA
				T _A = -20 to +85°C	—	—	60	μA
			V _{CCS} = 3.0 V	T _A = 25°C	—	1	2	μA
				T _A = -20 to +85°C	—	—	50	μA
V _{IL}	Input Low Level	—		-0.3	—	0.6	V	
V _{IH}	Input High Level	—		2.2	—	V _{CC} +0.3*	V	
V _{OL}	Output Low Voltage Level	I _{OL} = 2.1 mA, V _{CCf} = V _{CCS} = V _{CC} Min.		—	—	0.4	V	
V _{OH}	Output High Voltage Level	I _{OH} = -500 μA, V _{CCf} = V _{CCS} = V _{CC} Min.		V _{CC} -0.5	—	—	V	
V _{LKO}	Flash Low V _{CC} Lock-Out Voltage	—		2.3	—	2.5	V	

* : V_{CC} indicate lower of V_{CCf} or V_{CCS}

** : During standby mode with $\overline{CE}1s = V_{CCS} - 0.2\text{ V}$, CE2s should be CE2s < 0.2V or CE2s > V_{CCS} - 0.2V

■ AC CHARACTERISTICS

• CE Timing

Parameter Symbols		Description	Test Setup		-10	Unit
JEDEC	Standard					
—	t_{CCR}	CE Recover Time	—	Min.	0	ns

• Timing Diagram for alternating SRAM to Flash

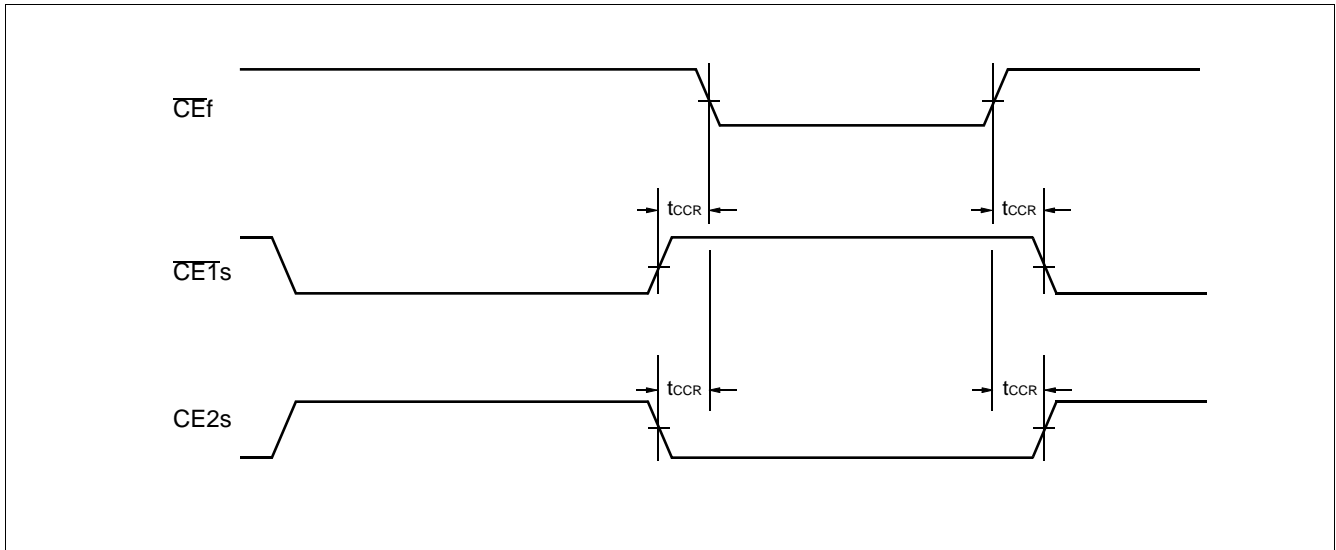

MB84VA2102-10/MB84VA2103-10

• Read Only Operations Characteristics (Flash)

Parameter Symbols		Description	Test Setup	-10 (Note)		Unit
JEDEC	Standard			Min.	Max.	
t _{AVAV}	t _{RC}	Read Cycle Time	—	100	—	ns
t _{AVQV}	t _{ACC}	Address to Output Delay	$\overline{CE}f = V_{IL}$ $\overline{OE} = V_{IL}$	—	100	ns
t _{ELQV}	t _{CEf}	Chip Enable to Output Delay	$\overline{OE} = V_{IL}$	—	100	ns
t _{GLQV}	t _{OE}	Output Enable to Output Delay	—	—	40	ns
t _{EHQZ}	t _{DF}	Chip Enable to Output High-Z	—	—	30	ns
t _{GHQZ}	t _{DF}	Output Enable to Output High-Z	—	—	30	ns
t _{AXQX}	t _{OH}	Output Hold Time From Addresses, $\overline{CE}f$ or \overline{OE} , Whichever Occurs First	—	0	—	ns
—	t _{READY}	RESET Pin Low to Read Mode	—	—	20	μs

Note: Test Conditions—Output Load: 1 TTL gate and 30 pF
 Input rise and fall times: 5 ns
 Input pulse levels: 0.0 V to 3.0 V
 Timing measurement reference level
 Input: 1.5 V
 Output: 1.5 V

MB84VA2102-10/MB84VA2103-10

• Read Cycle (Flash)

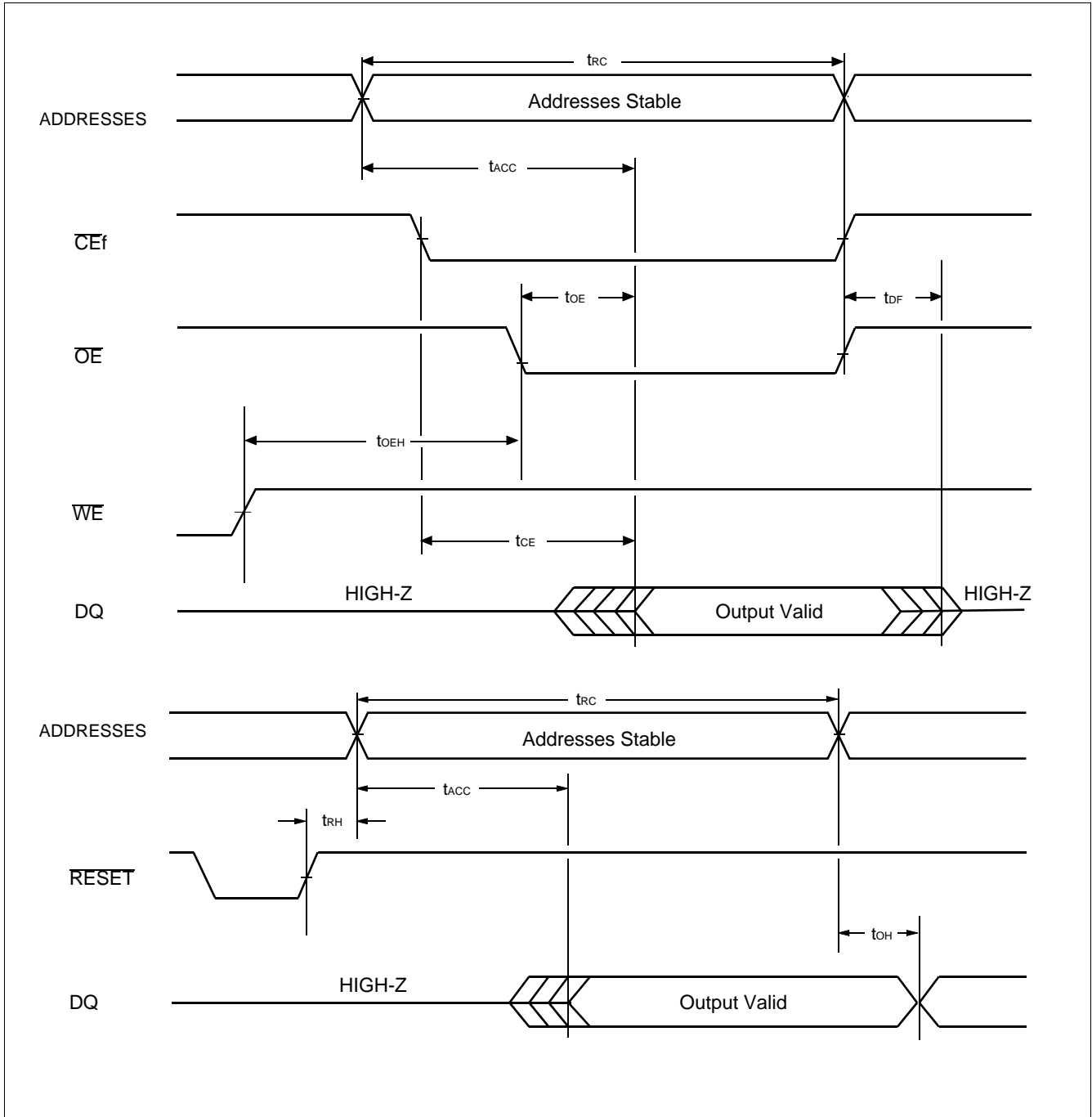

MB84VA2102-10/MB84VA2103-10

• Erase/Program Operations (Flash)

Parameter Symbols		Description	-10			Unit
JEDEC	Standard		Min.	Typ.	Max.	
tAVAV	tWC	Write Cycle Time	100	—	—	ns
tAVWL	tAS	Address Setup Time (\overline{WE} to Addr.)	0	—	—	ns
tAVEL	tAS	Address Setup Time (\overline{CEf} to Addr.)	0	—	—	ns
tWLAX	tAH	Address Hold Time (\overline{WE} to Addr.)	50	—	—	ns
tELAX	tAH	Address Hold Time (\overline{CEf} to Addr.)	50	—	—	ns
tDVWH	tDS	Data Setup Time	50	—	—	ns
tWHDX	tDH	Data Hold Time	0	—	—	ns
—	toES	Output Enable Setup Time	0	—	—	ns
—	toEH	Output Enable Hold Time	0	—	—	ns
		Read Toggle and Data Polling	10	—	—	ns
tGHEL	tGHEL	Read Recover Time Before Write (\overline{OE} to \overline{CEf})	0	—	—	ns
tGHWL	tGHWL	Read Recover Time Before Write (\overline{OE} to \overline{WE})	0	—	—	ns
tWLEL	tWS	\overline{WE} Setup Time (\overline{CEf} to \overline{WE})	0	—	—	ns
tELWL	tCS	\overline{CEf} Setup Time (\overline{WE} to \overline{CEf})	0	—	—	ns
tEHWL	tWH	\overline{WE} Hold Time (\overline{CEf} to \overline{WE})	0	—	—	ns
tWHEH	tCH	\overline{CEf} Hold Time (\overline{WE} to \overline{CEf})	0	—	—	ns
tWLWH	tWP	Write Pulse Width	50	—	—	ns
tLELH	tCP	\overline{CEf} Pulse Width	50	—	—	ns
tWHWL	tWPH	Write Pulse Width High	30	—	—	ns
tEHEL	tCPH	\overline{CEf} Pulse Width High	30	—	—	ns
tWHWH1	tWHWH1	Programming Operation	—	16	—	μ s
tWHWH2	tWHWH2	Sector Erase Operation (Note 1)	—	1	—	sec
			—	—	15	sec
—	tVCS	V _{ccf} Setup Time	50	—	—	μ s
—	tVLHT	Voltage Transition Time (Note 2)	4	—	—	μ s
—	tVIDR	Rise Time to V _{ID} (Note 2)	500	—	—	ns
—	tRB	Recover Time from RY/BY	0	—	—	ns
—	tRP	RESET Pulse Width	500	—	—	ns
—	tRH	RESET Hold Time Before Read	200	—	—	ns
—	tEOE	Delay Time from Embedded Output Enable	—	—	100	ns
—	tBUSY	Program/Erase Valid to RY/BY Delay	—	—	90	ns

Note : 1. This does not include the preprogramming time.

2. This timing is for Sector Protection Operation.

MB84VA2102-10/MB84VA2103-10

• Write Cycle (\overline{WE} control) (Flash)

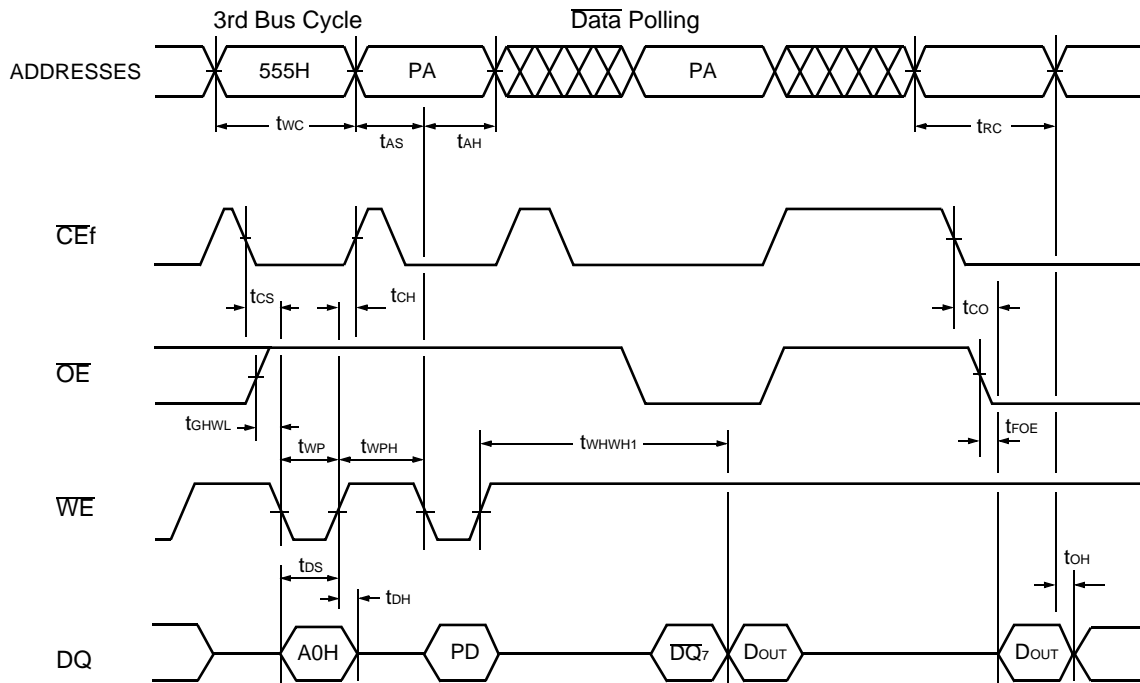

- Notes:**
1. PA is address of the memory location to be programmed.
 2. PD is data to be programmed at byte address.
 3. \overline{DQ}_7 is the output of the complement of the data written to the device.
 4. D_{OUT} is the output of the data written to the device.
 5. Figure indicates last two bus cycles out of four bus cycle sequence

• Write Cycle (\overline{CEf} control) (Flash)

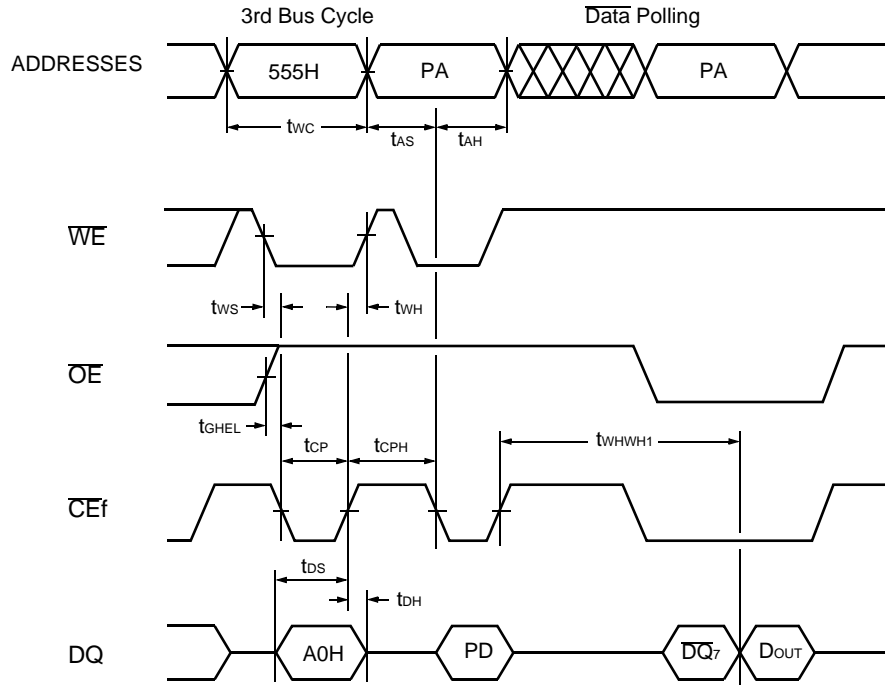

- Notes:**
1. PA is address of the memory location to be programmed.
 2. PD is data to be programmed at byte address.
 3. \overline{DQ}_7 is the output of the complement of the data written to the device.
 4. D_{OUT} is the output of the data written to the device.
 5. Figure indicates last two bus cycles out of four bus cycle sequence.

MB84VA2102-10/MB84VA2103-10

• AC Waveforms Chip/Sector Erase Operations (Flash)

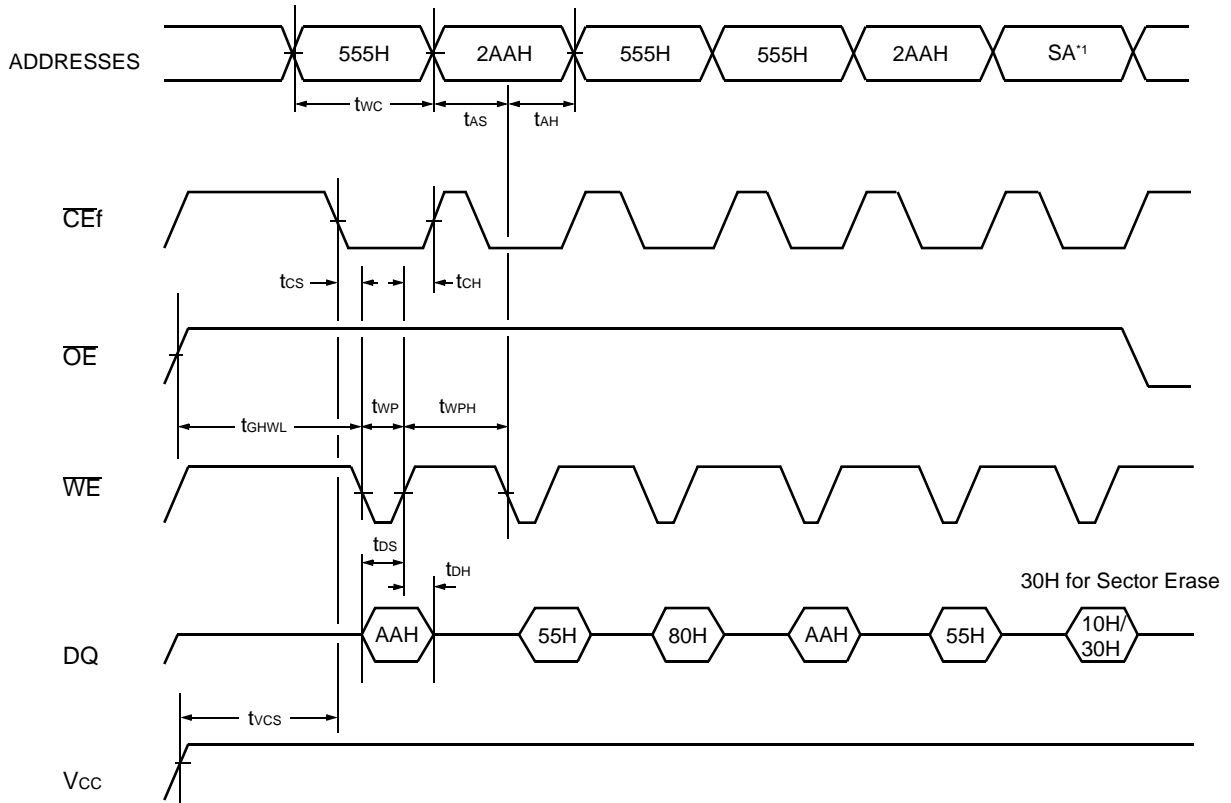

Notes: 1. SA is the sector address for Sector Erase. Addresses = 555H for Chip Erase.

MB84VA2102-10/MB84VA2103-10

• AC Waveforms for Data Polling during Embedded Algorithm Operations (Flash)

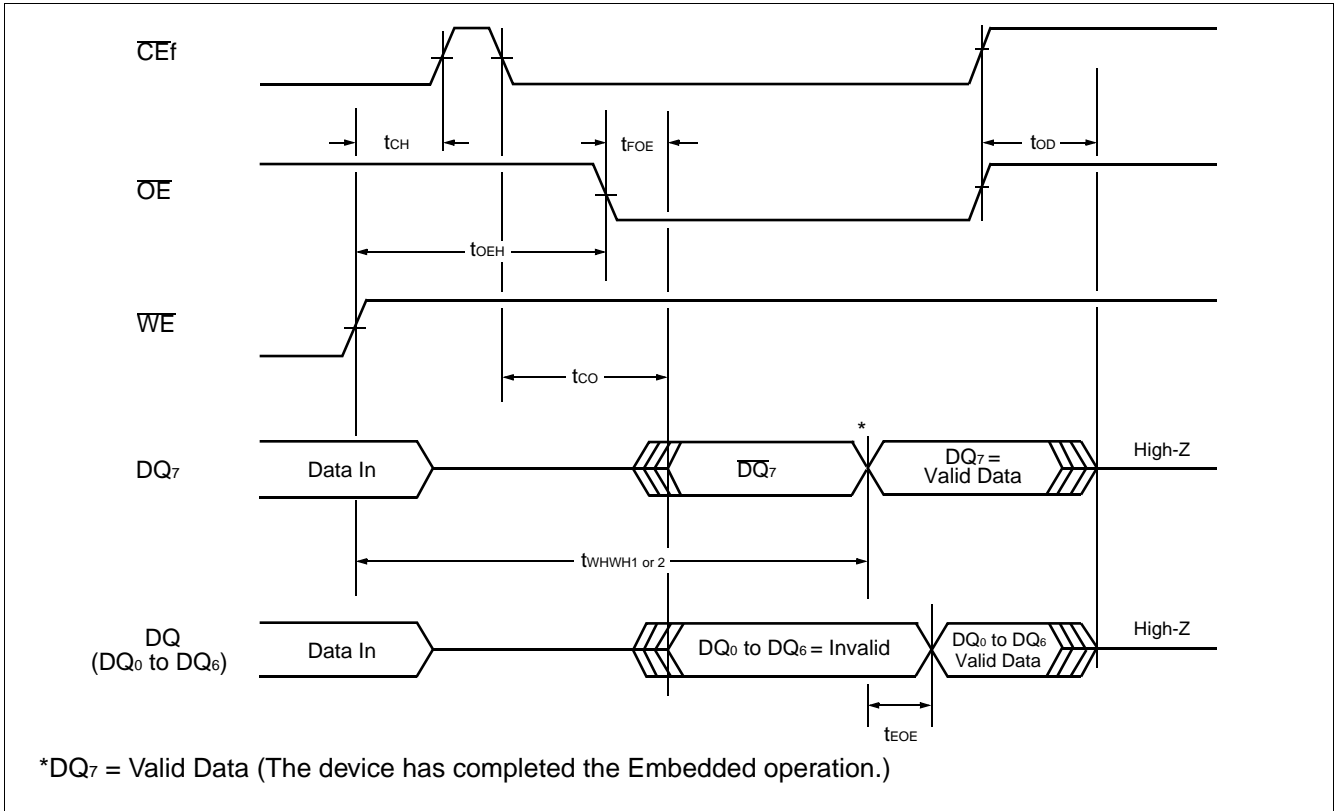

• AC Waveforms for Toggle Bit during Embedded Algorithm Operations (Flash)

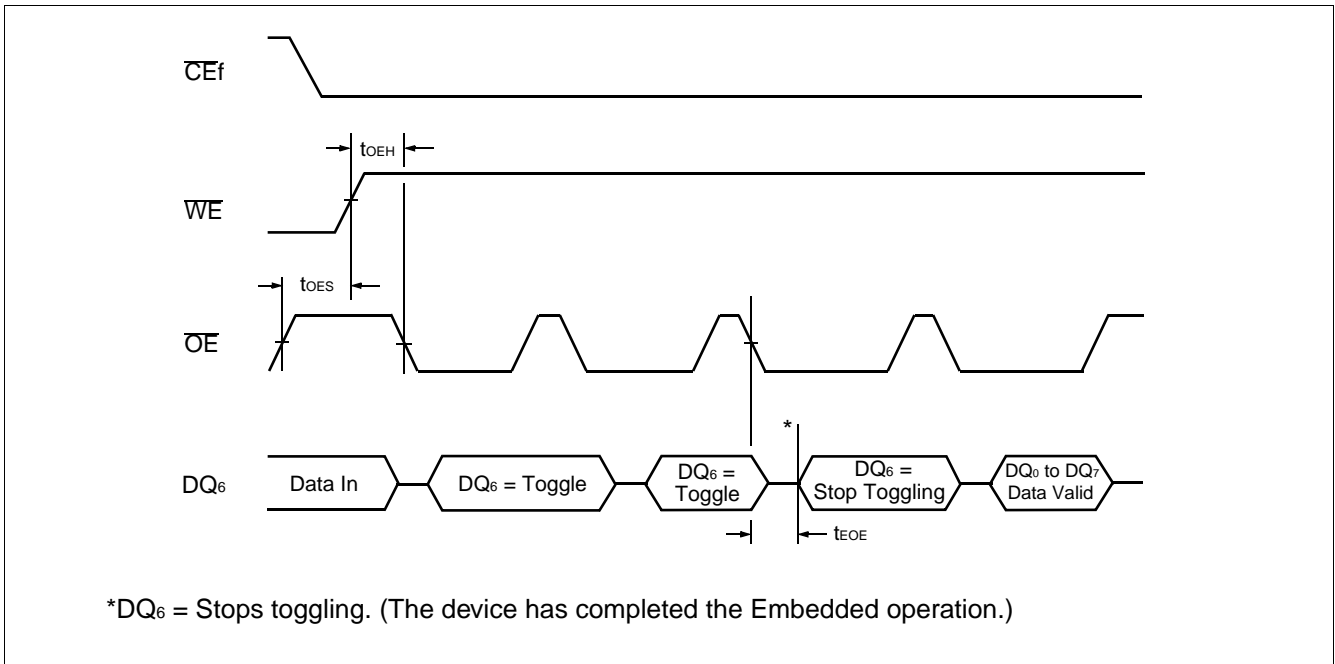

MB84VA2102-10/MB84VA2103-10

• RY/BY Timing Diagram during Write/Erase Operations (Flash)

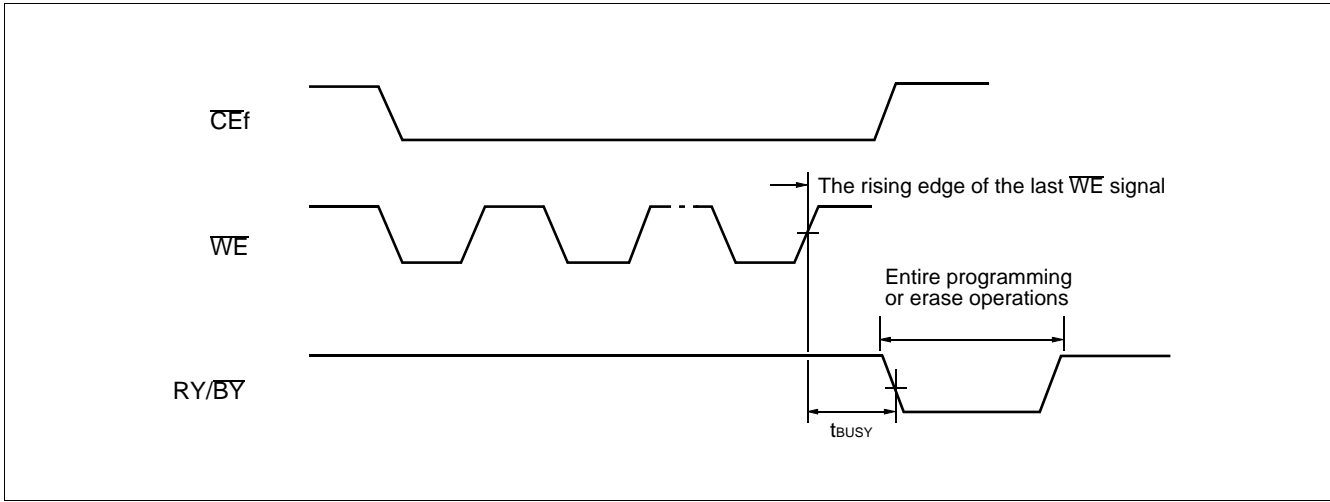

• RESET, RY/BY Timing Diagram (Flash)

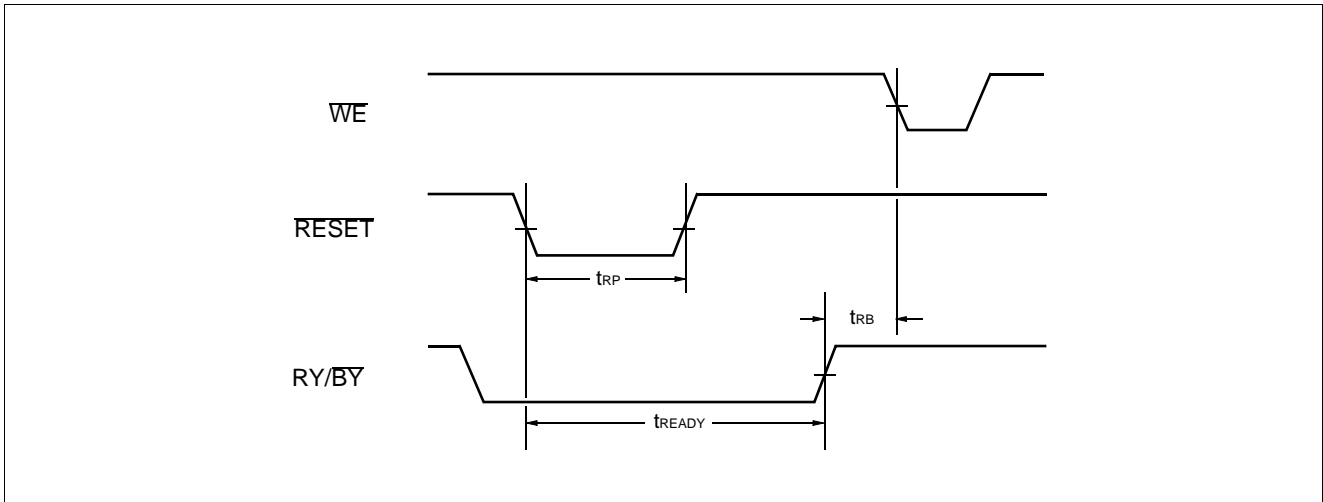

• Temporary Sector Unprotection (Flash)

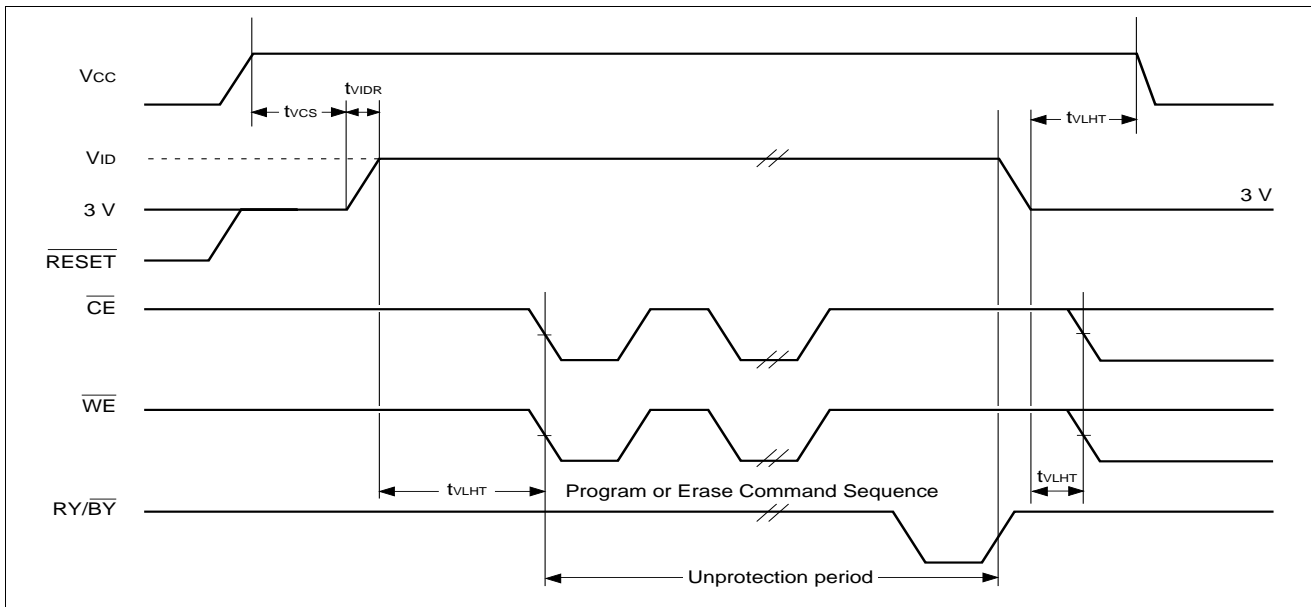

• Extended Sector Protection (Flash)

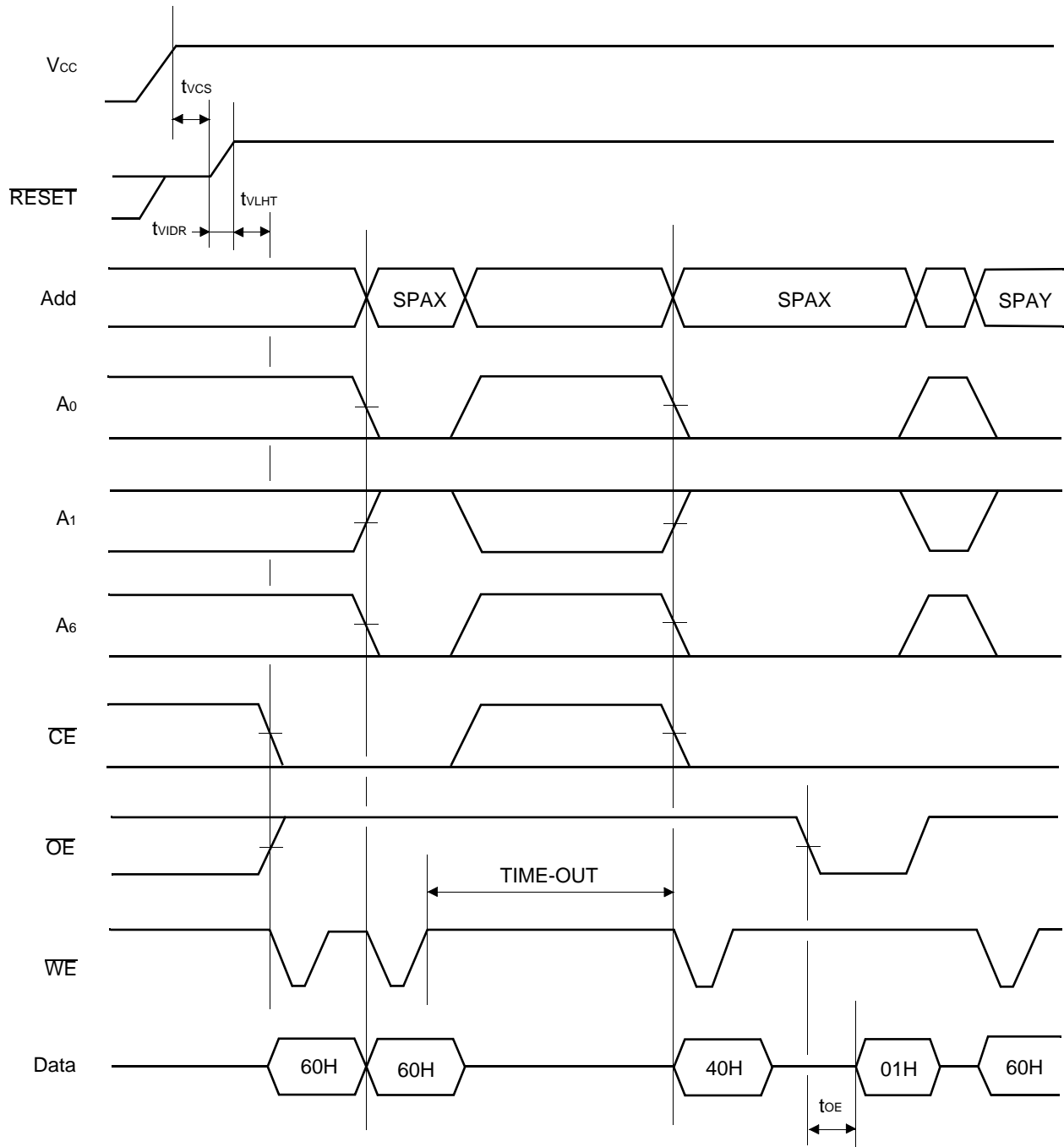

SPAX : Sector Address to be protected
 SPAY : Next Sector Address to be protected
 TIME-OUT : Time-Out window = 150 μ s (min)

MB84VA2102-10/MB84VA2103-10

• Read Cycle (SRAM)

Parameter Symbol	Parameter Description	Min.	Max.	Unit
t_{RC}	Read Cycle Time	100	—	ns
t_{AA}	Address Access Time	—	100	ns
t_{CO1}	Chip Enable ($\overline{CE1}$ s) Access Time	—	100	ns
t_{CO2}	Chip Enable ($CE2$ s) Access Time	—	100	ns
t_{OE}	Output Enable Access Time	—	50	ns
t_{COE}	Chip Enable ($\overline{CE1}$ s Low and $CE2$ s High) to Output Active	5	—	ns
t_{OEE}	Output Enable Low to Output Active	0	—	ns
t_{OD}	Chip Enable ($\overline{CE1}$ s High or $CE2$ s Low) to Output High-Z	—	40	ns
t_{ODO}	Output Enable High to Output High-Z	—	40	ns
t_{OH}	Output Data Hold Time	10	—	ns

• Read Cycle (Note 1) (SRAM)

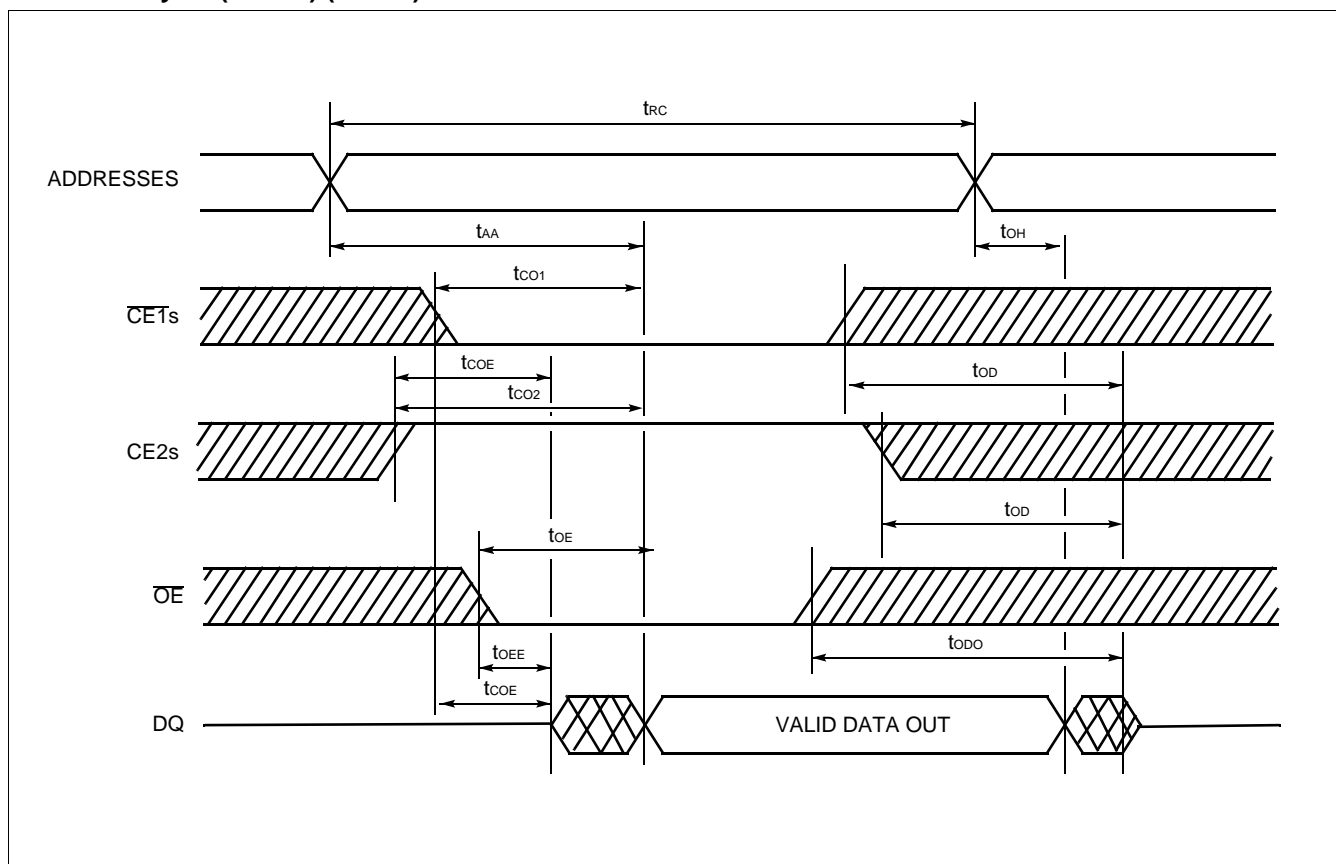

Note: 1. \overline{WE} remains HIGH for the read cycle.

• Write Cycle (SRAM)

Parameter Symbol	Parameter Description	Min.	Max.	Unit
t_{WC}	Write Cycle Time	100	—	ns
t_{WP}	Write Pulse Width	60	—	ns
t_{CW}	Chip Enable to End of Write	80	—	ns
t_{AS}	Address Setup Time	0	—	ns
t_{WR}	Write Recovery Time	0	—	ns
t_{ODW}	\overline{WE} Low to Output High-Z	—	40	ns
t_{OEW}	\overline{WE} High to Output Active	0	—	ns
t_{DS}	Data Setup Time	40	—	ns
t_{DH}	Data Hold Time	0	—	ns

• Write Cycle (Note 4) (\overline{WE} control) (SRAM)

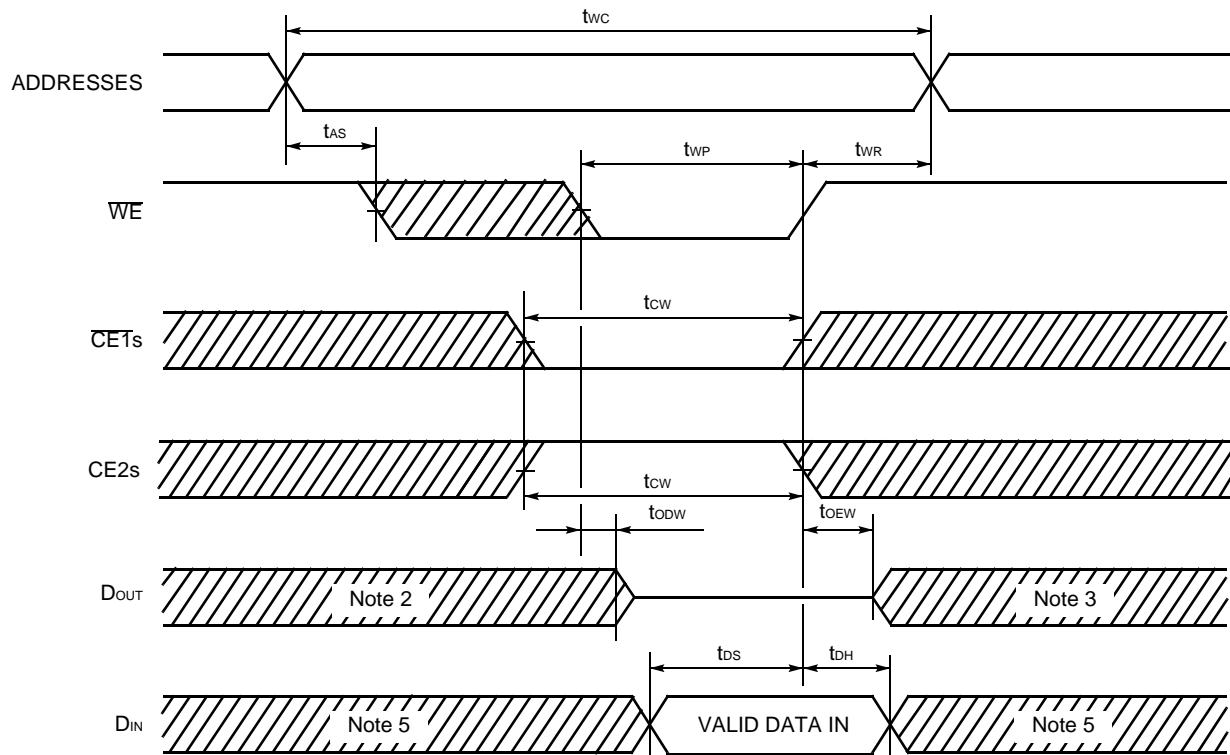

- Notes:**
- 2.If $\overline{CE1s}$ goes LOW (or $CE2s$ goes HIGH) coincident with or after \overline{WE} goes LOW, the output will remain at high impedance.
 - 3.If $\overline{CE1s}$ goes HIGH (or $CE2s$ goes LOW) coincident with or before \overline{WE} goes HIGH, the output will remain at high impedance.
 - 4.If \overline{OE} is HIGH during the write cycle, the outputs will remain at high impedance.
 - 5.Because I/O signals may be in the output state at this Time, input signals of reverse polarity must not be applied.

MB84VA2102-10/MB84VA2103-10

• Write Cycle (Note 4) ($\overline{CE1s}$ control) (SRAM)

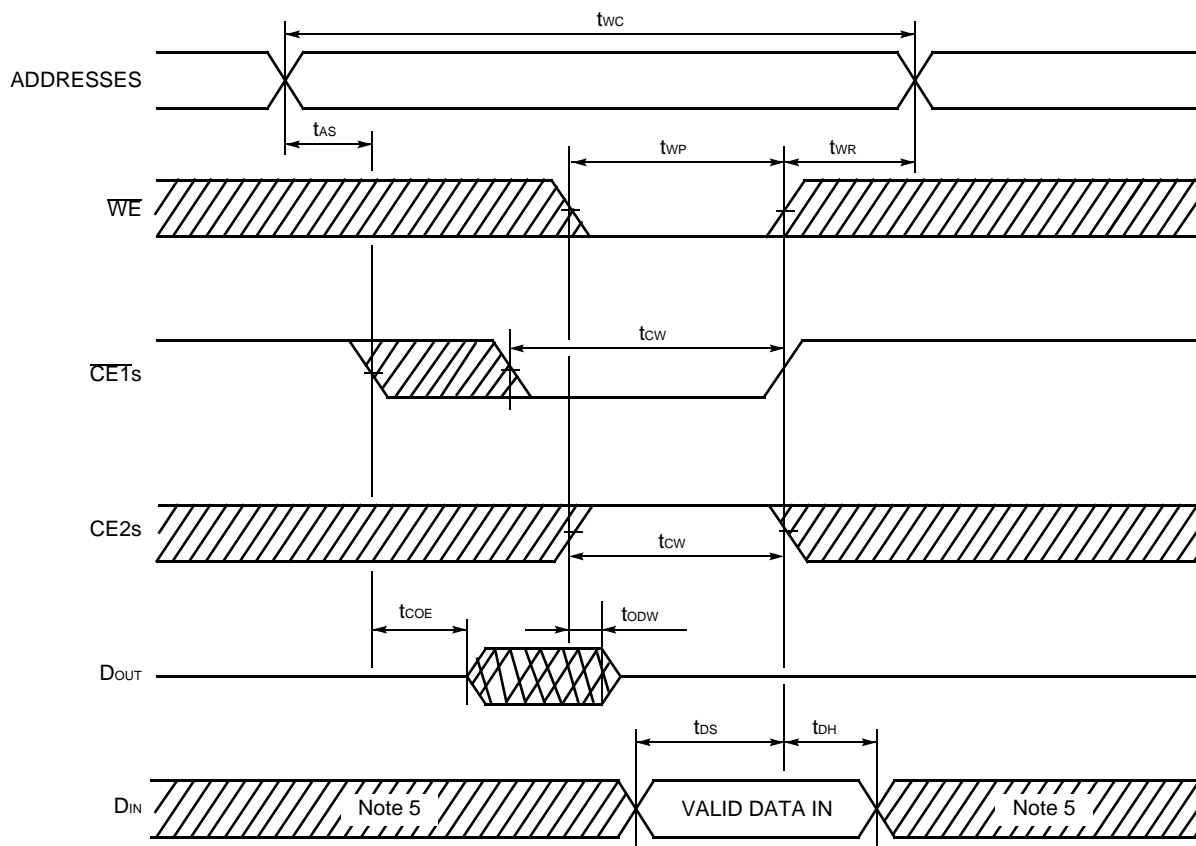

- Notes:**
- 2.If $\overline{CE1s}$ goes LOW (or $CE2s$ goes HIGH) coincident with or after \overline{WE} goes LOW, the output will remain at high impedance.
 - 3.If $\overline{CE1s}$ goes HIGH (or $CE2s$ goes LOW) coincident with or before \overline{WE} goes HIGH, the output will remain at high impedance.
 - 4.If \overline{OE} is HIGH during the write cycle, the outputs will remain at high impedance.
 - 5.Because I/O signals may be in the output state at this Time, input signals of reverse polarity must not be applied.

• Write Cycle (Note 4) (CE2s Control) (SRAM)

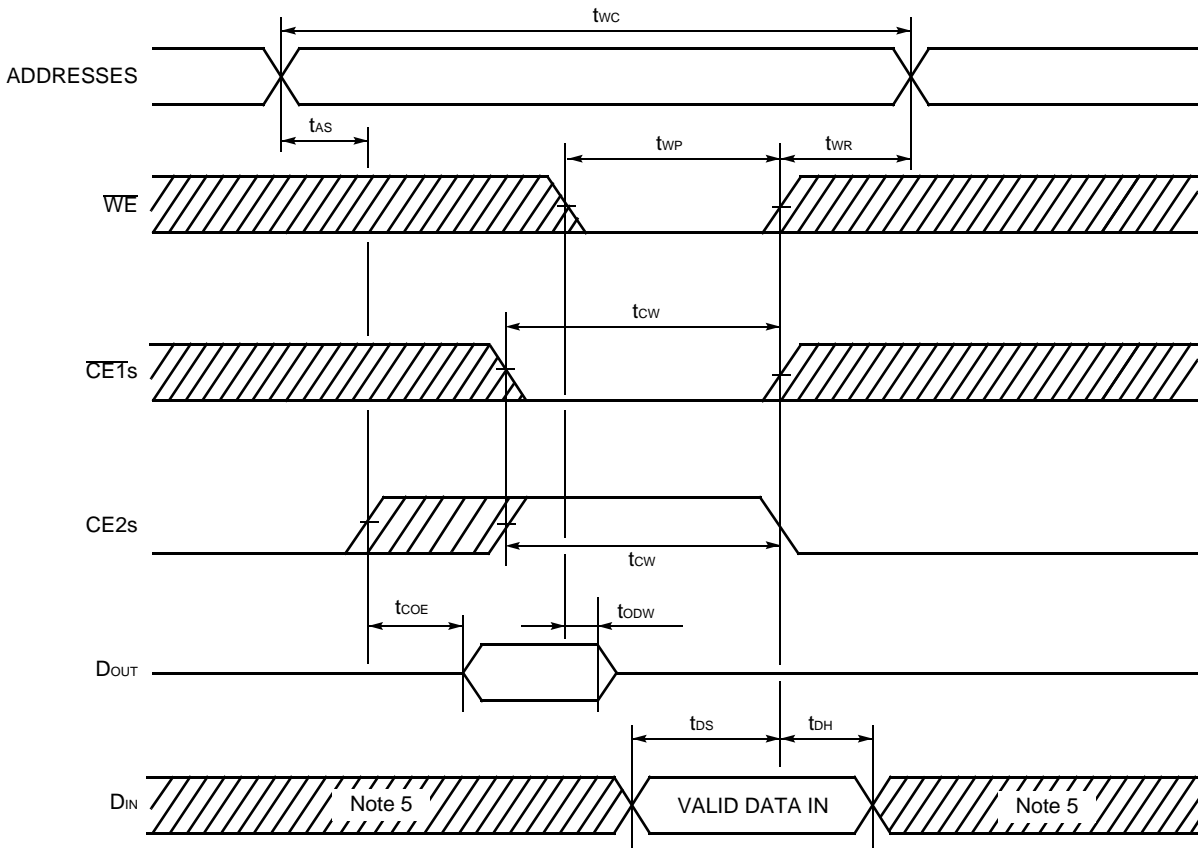

- Notes:**
- 2.If $\overline{CE1s}$ goes LOW (or CE2s goes HIGH) coincident with or after \overline{WE} goes LOW, the output will remain at high impedance.
 - 3.If $\overline{CE1s}$ goes HIGH (or CE2s goes LOW) coincident with or before \overline{WE} goes HIGH, the output will remain at high impedance.
 - 4.If \overline{OE} is HIGH during the write cycle, the outputs will remain at high impedance.
 - 5.Because I/O signals may be in the output state at this Time, input signals of reverse polarity must not be applied.

MB84VA2102-10/MB84VA2103-10

■ ERASE AND PROGRAMMING PERFORMANCE (Flash)

Parameter	Limits			Unit	Comment
	Min.	Typ.	Max.		
Sector Erase Time	—	1	15	sec	Excludes programming time prior to erasure
Programming Time	—	16	5,200	μs	Excludes system-level overhead
Chip Programming Time	—	16.8	100	sec	Excludes system-level overhead
Erase/Program Cycle	100,000	—	—	cycles	

■ DATA RETENTION CHARACTERISTICS (SRAM)

Parameter Symbol	Parameter Description	Min.	Typ.	Max.	Unit
V _{DH}	Data Retention Supply Voltage	2.0	—	3.6	V
I _{DDs2}	Standby Current	V _{DH} = 3.0 V	—	50*	μA
		V _{DH} = 3.6 V	—	60	μA
t _{CDR}	Chip Deselect to Data Retention Mode Time	0	—	—	ns
t _R	Recovery Time	5	—	—	ms

* : 5 μA (Max.) at T_A = -20°C to +40°C

• CE_Ts Controlled Data Retention Mode (Note 1)

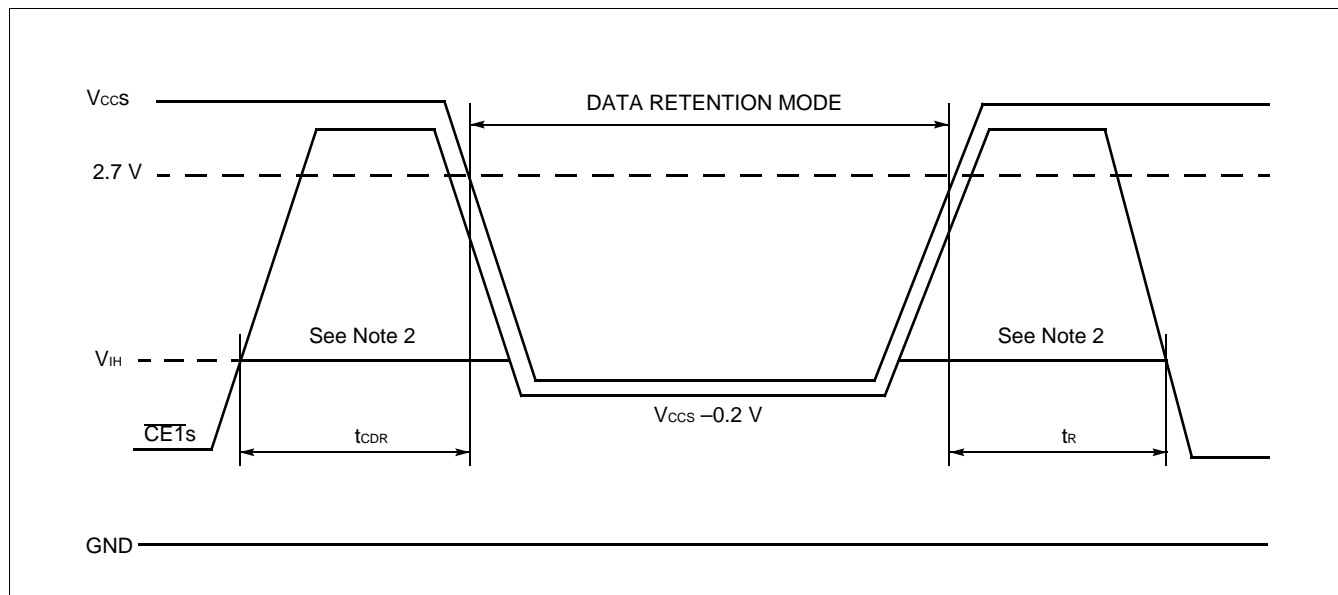

• CE2s Controlled Data Retention Mode (Note 3)

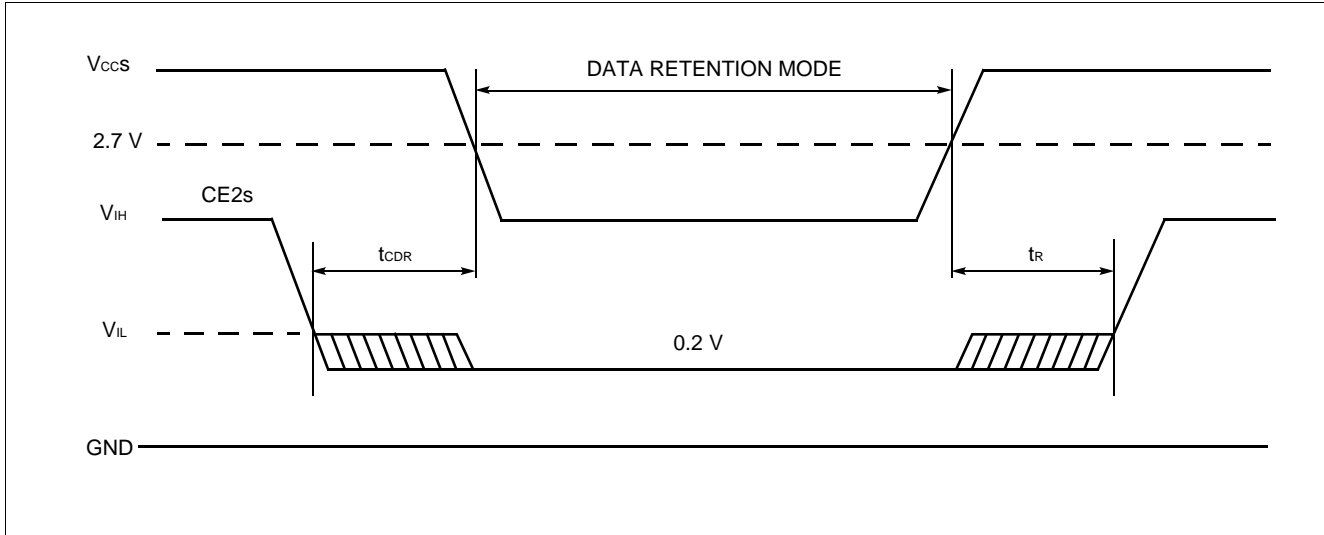

- Notes:**
1. In CE1s controlled data retention mode, input level of CE2s should be fixed Vccs to Vccs-0.2V or Vss to 0.2V during data retention mode. Other input and input/output pins can be used between -0.3V to Vccs+0.3V.
 2. When CE1s is operating at the Vih min. level (2.2 V), the standby current is given by IsB1S during the transition of Vccs from 3.6 to 2.2 V.
 3. In CE2s controlled data retention mode, input and input/output pins can be used between -0.3V to Vccs+0.3V.

■ PIN CAPACITANCE

Parameter Symbol	Parameter Description	Test Setup	Typ.	Max.	Unit
C _{IN}	Input Capacitance	V _{IN} = 0	T.B.D	T.B.D	pF
C _{OUT}	Output Capacitance	V _{OUT} = 0	T.B.D	T.B.D	pF
C _{IN2}	Control Pin Capacitance	V _{IN} = 0	T.B.D	T.B.D	pF

Note: Test conditions T_A = 25°C, f = 1.0 MHz

■ HANDLING OF PACKAGE

Please handle this package carefully since the sides of packages are right angle.

■ CAUTION

- 1)The high voltage (VID) can not apply to address pins and control pins except **RESET**. Therefore, it can not use autoselect and sector protect function by applying the high voltage (VID) to specific pins.
- 2)For the sector protection, since the high voltage (VID) can be applied to the **RESET**, it can be protected the sector using "Extended sector protect" command.

MB84VA2102-10/MB84VA2103-10

■ PACKAGE

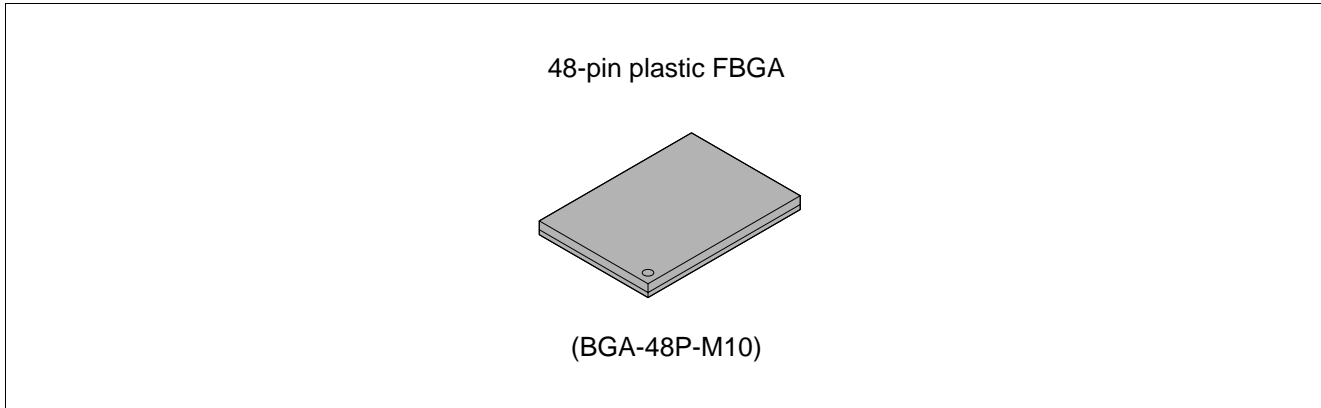

■ PACKAGE DIMENSIONS

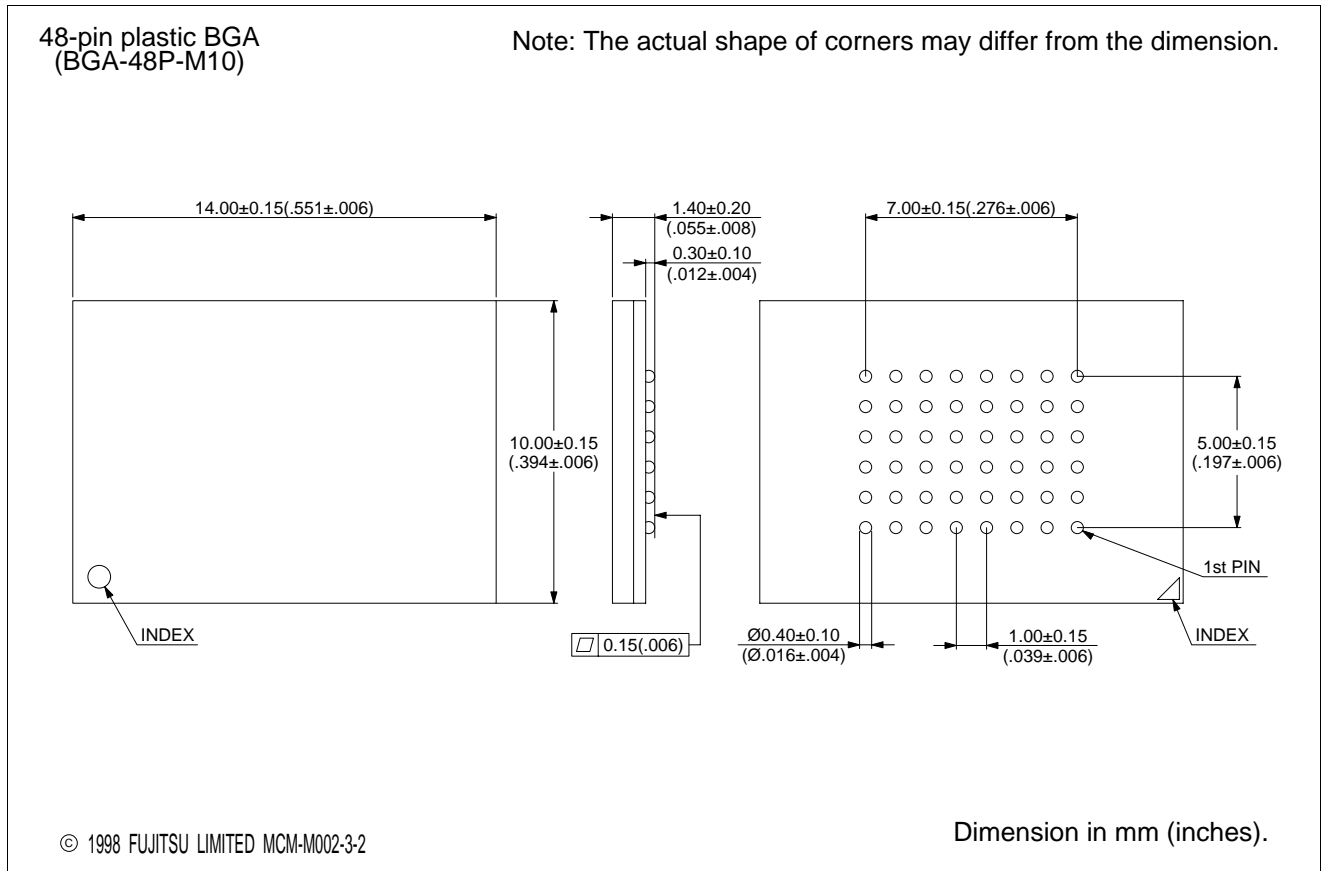

FUJITSU LIMITED

For further information please contact:

Japan

FUJITSU LIMITED
Corporate Global Business Support Division
Electronic Devices
KAWASAKI PLANT, 4-1-1, Kamikodanaka
Nakahara-ku, Kawasaki-shi
Kanagawa 211-8588, Japan
Tel: (044) 754-3763
Fax: (044) 754-3329

<http://www.fujitsu.co.jp/>

North and South America

FUJITSU MICROELECTRONICS, INC.
Semiconductor Division
3545 North First Street
San Jose, CA 95134-1804, USA
Tel: (408) 922-9000
Fax: (408) 922-9179

Customer Response Center
Mon. - Fri.: 7 am - 5 pm (PST)
Tel: (800) 866-8608
Fax: (408) 922-9179

<http://www.fujitsumicro.com/>

Europe

FUJITSU MIKROELEKTRONIK GmbH
Am Siebenstein 6-10
D-63303 Dreieich-Buchsschlag
Germany
Tel: (06103) 690-0
Fax: (06103) 690-122

<http://www.fujitsu-edc.com/>

Asia Pacific

FUJITSU MICROELECTRONICS ASIA PTE LTD
#05-08, 151 Lorong Chuan
New Tech Park
Singapore 556741
Tel: (65) 281-0770
Fax: (65) 281-0220

<http://www.fmap.com.sg/>

F9805

© FUJITSU LIMITED Printed in Japan

All Rights Reserved.

The contents of this document are subject to change without notice. Customers are advised to consult with FUJITSU sales representatives before ordering.

The information and circuit diagrams in this document presented as examples of semiconductor device applications, and are not intended to be incorporated in devices for actual use. Also, FUJITSU is unable to assume responsibility for infringement of any patent rights or other rights of third parties arising from the use of this information or circuit diagrams.

FUJITSU semiconductor devices are intended for use in standard applications (computers, office automation and other office equipment, industrial, communications, and measurement equipment, personal or household devices, etc.).

CAUTION:

Customers considering the use of our products in special applications where failure or abnormal operation may directly affect human lives or cause physical injury or property damage, or where extremely high levels of reliability are demanded (such as aerospace systems, atomic energy controls, sea floor repeaters, vehicle operating controls, medical devices for life support, etc.) are requested to consult with FUJITSU sales representatives before such use. The company will not be responsible for damages arising from such use without prior approval.

Any semiconductor devices have inherently a certain rate of failure. You must protect against injury, damage or loss from such failures by incorporating safety design measures into your facility and equipment such as redundancy, fire protection, and prevention of over-current levels and other abnormal operating conditions.

If any products described in this document represent goods or technologies subject to certain restrictions on export under the Foreign Exchange and Foreign Trade Control Law of Japan, the prior authorization by Japanese government should be required for export of those products from Japan.