

MCP (Multi-Chip Package) FLASH MEMORY & SRAM
CMOS

8M (× 16) FLASH MEMORY & 2M (× 16) STATIC RAM

MB84VD2008-10/MB84VD2009-10

■ FEATURES

- Power supply voltage of 2.7 to 3.6 V
- High performance
100 ns maximum access time
- Operating Temperature
-20 to +85°C

— FLASH MEMORY

- Simultaneous operations Read-while Erase or Read-while-Program
- Minimum 100,000 write/erase cycles
- Sector erase architecture
Two 16 K byte, four 8 K bytes, two 32 K byte, and fourteen 64 K bytes.
Any combination of sectors can be concurrently erased. Also supports full chip erase.
- Boot Code Sector Architecture
MB84VD2008: Top sector
MB84VD2009: Bottom sector
- Embedded Erase™ Algorithms
Automatically pre-programs and erases the chip or any sector
- Embedded Program™ Algorithms
Automatically writes and verifies data at specified address
- Data Polling and Toggle Bit feature for detection of program or erase cycle completion
- Ready-Busy output (RY/BY)
Hardware method for detection of program or erase cycle completion
- Automatic sleep mode
When addresses remain stable, automatically switch themselves to low power mode.
- Low V_{cc} write inhibit ≤ 2.5 V
- Erase Suspend/Resume
Suspends the erase operation to allow a read in another sector within the same device
- Please refer to "MBM29DL800TA/BA" data sheet in detailed function

— SRAM

- Power dissipation
Operating : 50 mA max.
Standby : 50 μA max.
- Data retention supply voltage: 2.0 V to 3.6 V

MB84VD2008-10/MB84VD2009-10

■ BLOCK DIAGRAM

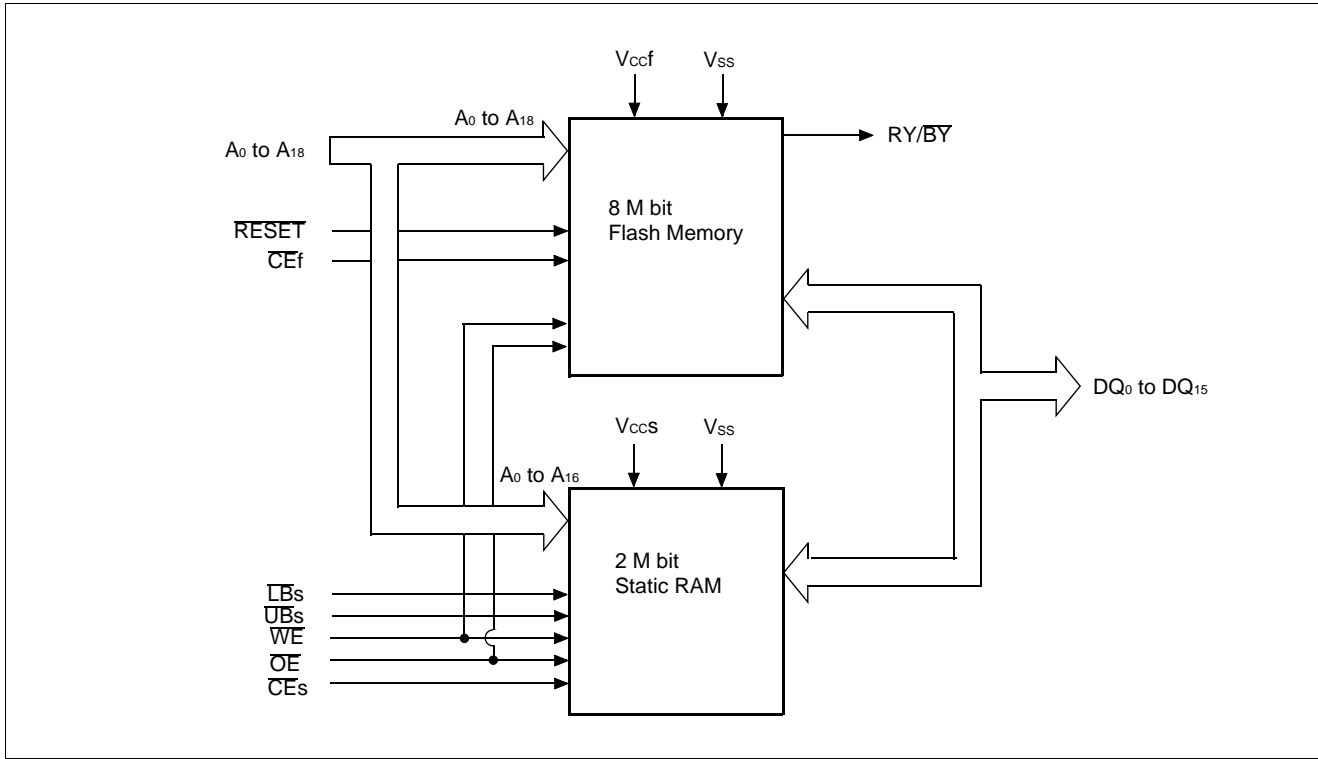

■ PIN ASSIGNMENTS

(Top View)

	A	B	C	D	E	F	G	H
6	\overline{CE}_s	V_{SS}	DQ ₁	A ₁	A ₂	A ₄	N.C.	A ₉
5	A ₁₀	DQ ₅	DQ ₂	A ₀	A ₃	A ₇	RY/ \overline{BY}	A ₁₄
4	\overline{OE}	DQ ₇	DQ ₄	DQ ₀	A ₆	A ₁₈	RESET	A ₁₅
3	A ₁₁	A ₈	A ₅	DQ ₈	DQ ₃	DQ ₁₂	A ₁₂	\overline{LB}_s
2	A ₁₃	A ₁₇	\overline{UB}_s	\overline{CE}_f	DQ ₁₀	V_{ccf}	DQ ₆	DQ ₁₅
1	\overline{WE}	V_{CCS}	A ₁₆	V_{SS}	DQ ₉	DQ ₁₁	DQ ₁₃	DQ ₁₄

Table 1 Pin Configuration

Pin	Function	Input/ Output
A ₀ to A ₁₆	Address Inputs (Common)	I
A ₁₇ to A ₁₈	Address Input (Flash)	I
DQ ₀ to DQ ₁₅	Data Inputs/Outputs (Common)	I/O
\overline{CE}_f	Chip Enable (Flash)	I
\overline{CE}_s	Chip Enable (SRAM)	I
\overline{OE}	Output Enable (Common)	I
\overline{WE}	Write Enable (Common)	I
RY/ \overline{BY}	Ready/Busy Outputs (Flash)	O
\overline{UB}_s	Upper Byte Control (SRAM)	I
\overline{LB}_s	Lower Byte Control (SRAM)	I
RESET	Hardware Reset Pin/Sector Protection Unlock (Flash)	I
N.C.	No Internal Connection	—
V_{SS}	Device Ground (Common)	Power
V_{ccf}	Device Power Supply (Flash)	Power
V_{CCS}	Device Power Supply (SRAM)	Power

MB84VD2008-10/MB84VD2009-10

■ PRODUCT LINE UP

		Flash Memory	SRAM
Ordering Part No.	$V_{CC} = 3.0\text{ V} \begin{matrix} +0.6\text{ V} \\ -0.3\text{ V} \end{matrix}$	MB84VD2008-10/MB84VD2009-10	
Max. Address Access Time (ns)		100	85
Max. \overline{CE} Access Time (ns)		100	85
Max. \overline{OE} Access Time (ns)		40	45

■ BUS OPERATIONS

Table 2 User Bus Operations

Operation (1), (3)	\overline{CEf}	\overline{CEs}	\overline{OE}	\overline{WE}	\overline{LBs}	\overline{UBs}	DQ ₀ to DQ ₇	DQ ₈ to DQ ₁₅	RESET
Full Standby	H	H	X	X	X	X	HIGH-Z	HIGH-Z	H
Output Disable	H	L	H	H	X	X	HIGH-Z	HIGH-Z	H
			X	X	H	H	HIGH-Z	HIGH-Z	
	L	H	H	H	X	X	HIGH-Z	HIGH-Z	
Read from Flash (2)	L	H	L	H	X	X	D _{OUT}	D _{OUT}	H
Write to Flash	L	H	H	L	X	X	D _{IN}	D _{IN}	H
Read from SRAM	H	L	L	H	L	L	D _{OUT}	D _{OUT}	H
					H	L	HIGH-Z	D _{OUT}	
					L	H	D _{OUT}	HIGH-Z	
Write to SRAM	H	L	X	L	L	L	D _{IN}	D _{IN}	H
					H	L	HIGH-Z	D _{IN}	
					L	H	D _{IN}	HIGH-Z	
Flash Hardware Reset	X	H	X	X	X	X	HIGH-Z	HIGH-Z	L

Legend: L = V_{IL}, H = V_{IH}, X = V_{IL} or V_{IH}. See DC Characteristics for voltage levels.

- Notes:**
- Other operations except for indicated this column are inhibited.
 - \overline{WE} can be V_{IL} if \overline{OE} is V_{IL}, \overline{OE} at V_{IH} initiates the write operations.
 - Do not apply $\overline{CEf} = V_{IL}$, $\overline{CEs} = V_{IL}$ at a time.

MB84VD2008-10/MB84VD2009-10

■ FLEXIBLE SECTOR-ERASE ARCHITECTURE on FLASH MEMORY

- Two 16 K byte, four 8 K bytes, two 32 K byte, and fourteen 64 K bytes.
- Individual-sector, multiple-sector, or bulk-erase capability.

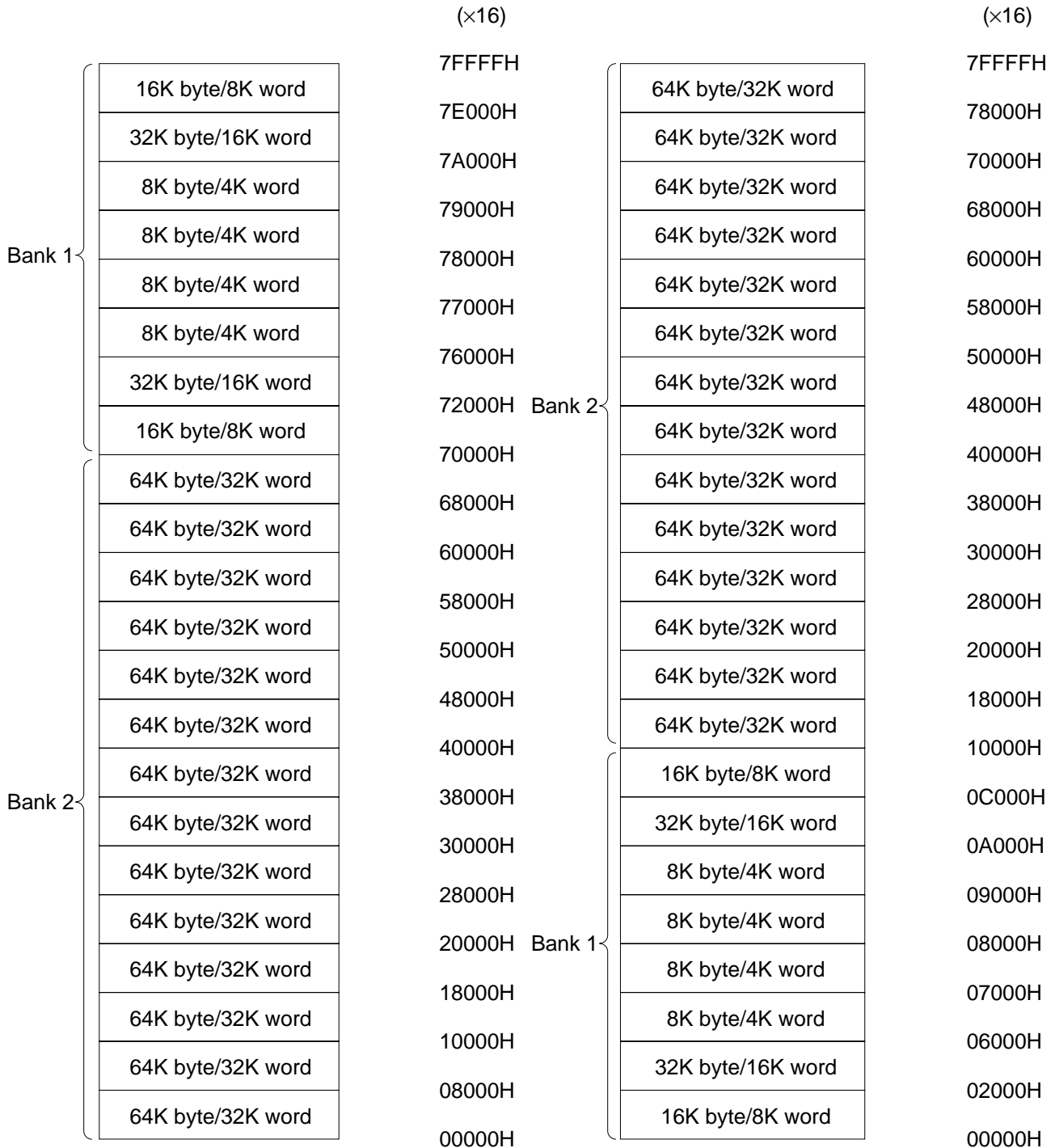

MB84VD2008 Sector Architecture

MB84VD2009 Sector Architecture

MB84VD2008-10/MB84VD2009-10

Table 4 Sector Address Tables (MB84DV2008)

Bank	Sector	Sector Address							Sector Size (Kbytes/ Kwords)	(×16) Address Range
		Bank Address			A ₁₅	A ₁₄	A ₁₃	A ₁₂		
		A ₁₈	A ₁₇	A ₁₆						
Bank 2	SA0	0	0	0	0	X	X	X	64/32	00000H to 07FFFH
	SA1	0	0	0	1	X	X	X	64/32	08000H to 0FFFFH
	SA2	0	0	1	0	X	X	X	64/32	10000H to 17FFFH
	SA3	0	0	1	1	X	X	X	64/32	18000H to 1FFFFH
	SA4	0	1	0	0	X	X	X	64/32	20000H to 27FFFH
	SA5	0	1	0	1	X	X	X	64/32	28000H to 2FFFFH
	SA6	0	1	1	0	X	X	X	64/32	30000H to 37FFFH
	SA7	0	1	1	1	X	X	X	64/32	38000H to 3FFFFH
	SA8	1	0	0	0	X	X	X	64/32	40000H to 47FFFH
	SA9	1	0	0	1	X	X	X	64/32	48000H to 4FFFFH
	SA10	1	0	1	0	X	X	X	64/32	50000H to 57FFFH
	SA11	1	0	1	1	X	X	X	64/32	58000H to 5FFFFH
	SA12	1	1	0	0	X	X	X	64/32	60000H to 67FFFH
SA13	1	1	0	1	X	X	X	64/32	68000H to 6FFFFH	
Bank 1	SA14	1	1	1	0	0	0	X	16/8	70000H to 71FFFH
	SA15	1	1	1	0	0	1	X	32/16	72000H to 73FFFH, 74000H to 75FFFH
						1	0	X		
	SA16	1	1	1	0	1	1	0	8/4	76000H to 76FFFH
	SA17	1	1	1	0	1	1	1	8/4	77000H to 77FFFH
	SA18	1	1	1	1	0	0	0	8/4	78000H to 78FFFH
	SA19	1	1	1	1	0	0	1	8/4	79000H to 79FFFH
	SA20	1	1	1	1	0	1	X	32/16	7A000H to 7BFFFH, 7C000H to 7DFFFH
1						0	X			
SA21	1	1	1	1	1	1	X	16/8	7E000H to 7FFFFH	

MB84VD2008-10/MB84VD2009-10

Table 5 Sector Address Tables (MB84DV2009)

Bank	Sector	Sector Address							Sector Size (Kbytes/ Kwords)	($\times 16$) Address Range
		Bank Address			A ₁₅	A ₁₄	A ₁₃	A ₁₂		
		A ₁₈	A ₁₇	A ₁₆						
Bank 2	SA21	1	1	1	1	X	X	X	64/32	78000H to 7FFFFH
	SA20	1	1	1	0	X	X	X	64/32	70000H to 77FFFH
	SA19	1	1	0	1	X	X	X	64/32	68000H to 6FFFFH
	SA18	1	1	0	0	X	X	X	64/32	60000H to 67FFFH
	SA17	1	0	1	1	X	X	X	64/32	58000H to 5FFFFH
	SA16	1	0	1	0	X	X	X	64/32	50000H to 57FFFH
	SA15	1	0	0	1	X	X	X	64/32	48000H to 4FFFFH
	SA14	1	0	0	0	X	X	X	64/32	40000H to 47FFFH
	SA13	0	1	1	1	X	X	X	64/32	38000H to 3FFFFH
	SA12	0	1	1	0	X	X	X	64/32	30000H to 37FFFH
	SA11	0	1	0	1	X	X	X	64/32	28000H to 2FFFFH
	SA10	0	1	0	0	X	X	X	64/32	20000H to 27FFFH
	SA9	0	0	1	1	X	X	X	64/32	18000H to 1FFFFH
SA8	0	0	1	0	X	X	X	64/32	10000H to 17FFFH	
Bank 1	SA7	0	0	0	1	1	1	X	16/8	0E000H to 0FFFFH
	SA6	0	0	0	1	1	0	X	32/16	0A000H to 0BFFFH, 0C000H to 0DFFFH
						0	1	X		
	SA5	0	0	0	1	0	0	1	8/4	09000H to 09FFFH
	SA4	0	0	0	1	0	0	0	8/4	08000H to 08FFFH
	SA3	0	0	0	0	1	1	1	8/4	07000H to 07FFFH
	SA2	0	0	0	0	1	1	0	8/4	06000H to 06FFFH
	SA1	0	0	0	0	1	0	X	32/16	04000H to 05FFFH, 02000H to 03FFFH
0						1	X			
SA0	0	0	0	0	0	0	X	16/8	00000H to 01FFFH	

MB84VD2008-10/MB84VD2009-10

Table 6. 1 Flash Memory Autoselect Codes

Type		A ₆	A ₁	A ₀	Code (HEX)
Manufacturer's Code		V _{IL}	V _{IL}	V _{IL}	04H
Device Code	MB84VD2008	V _{IL}	V _{IL}	V _{IH}	224AH
	MB84VD2009	V _{IL}	V _{IL}	V _{IH}	22CBH

Table 6. 2 Expanded Autoselect Code Table

Type		Code	DQ ₁₅	DQ ₁₄	DQ ₁₃	DQ ₁₂	DQ ₁₁	DQ ₁₀	DQ ₉	DQ ₈	DQ ₇	DQ ₆	DQ ₅	DQ ₄	DQ ₃	DQ ₂	DQ ₁	DQ ₀
Manufacturer's Code		0004H	0	0	0	0	0	0	0	0	0	0	0	0	0	1	0	0
Device Code	MB84VD2008	224AH	0	0	1	0	0	0	1	0	0	1	0	0	1	0	1	0
	MB84VD2009	22CBH	0	0	1	0	0	0	1	0	1	1	0	0	1	0	1	1

Table 7 Flash Memory Command Definitions

Com- mand Sequence	Bus Write Cycles Req'd	First Bus Write Cycle		Second Bus Write Cycle		Third Bus Write Cycle		Fourth Bus Read/Write Cycle		Fifth Bus Write Cycle		Sixth Bus Write Cycle	
		Addr.	Data	Addr.	Data	Addr.	Data	Addr.	Data	Addr.	Data	Addr.	Data
Read/Reset	1	XXXH	F0H	—	—	—	—	—	—	—	—	—	—
Read/Reset	3	555H	AAH	2AAH	55H	555H	F0H	RA	RD	—	—	—	—
Autoselect	3	555H	AAH	2AAH	55H	(BA) 555H	90H	—	—	—	—	—	—
Program	4	555H	AAH	2AAH	55H	555H	A0H	PA	PD	—	—	—	—
Chip Erase	6	555H	AAH	2AAH	55H	555H	80H	555H	AAH	2AAH	55H	555H	10H
Sector Erase	6	555H	AAH	2AAH	55H	555H	80H	555H	AAH	2AAH	55H	SA	30H
Erase Suspend	1	BA	B0H	—	—	—	—	—	—	—	—	—	—
Erase Resume	1	BA	30H	—	—	—	—	—	—	—	—	—	—
Set to Fast Mode	3	555H	AAH	2AAH	55H	555H	20H	—	—	—	—	—	—
Fast Program *	2	XXXH	A0H	PA	PD	—	—	—	—	—	—	—	—
Reset from Fast Mode *	2	BA	90H	XXXH	F0H	—	—	—	—	—	—	—	—
Extended Sector Protect	4	XXXH	60H	SPA	60H	SPA	40H	SPA	SD	—	—	—	—

- Notes:**
1. Address bits A₁₁ to A₁₈ = X = "H" or "L" for all address commands except or Program Address (PA), Sector Address (SA), and Bank Address (BA).
 2. Bus operations are defined in Tables 2 and 3.
 3. RA = Address of the memory location to be read
PA = Address of the memory location to be programmed
Addresses are latched on the falling edge of the write pulse.
SA = Address of the sector to be erased. The combination of A₁₈, A₁₇, A₁₆, A₁₅, A₁₄, A₁₃, and A₁₂ will uniquely select any sector.
BA = Bank Address (A₁₆ to A₁₈)
 4. RD = Data read from location RA during read operation.
PD = Data to be programmed at location PA. Data is latched on the falling edge of write pulse.
 5. SPA = Sector address to be protected. Set sector address (SA) and (A₆, A₁, A₀) = (0, 1, 0).
SD = Sector protection verify data. Output 01H at protected sector addresses and output 00H at unprotected sector addresses.
- * : This command is valid while Fast Mode.

MB84VD2008-10/MB84VD2009-10

■ ABSOLUTE MAXIMUM RATINGS

Storage Temperature	-55°C to +125°C
Ambient Temperature with Power Applied	-25°C to +85°C
Voltage with Respect to Ground All pins (Note)	-0.3 V to $V_{ccf} + 0.5$ V
	-0.3 V to $V_{ccs} + 0.5$ V
V_{ccf}/V_{ccs} Supply (Note)	-0.3 V to +4.6 V

Note: Minimum DC voltage on input or I/O pins are -0.5 V. During voltage transitions, inputs may negativeovershoot V_{ss} to -2.0 V for periods of up to 20 ns. Maximum DC voltage on output and I/O pins are $V_{ccf} + 0.5$ V or $V_{ccs} + 0.5$ V. During voltage transitions, outputs may positive overshoot to $V_{cc} + 2.0$ V for periods of up to 20 ns.

WARNING: Semiconductor devices can be permanently damaged by application of stress (voltage, current, temperature, etc.) in excess of absolute maximum ratings. Do not exceed these ratings.

■ RECOMMENDED OPERATING RANGES

Commercial Devices

Ambient Temperature (T_A)	-20°C to +85°C
V_{ccf}/V_{ccs} Supply Voltages.....	+2.7 V to +3.6 V

Operating ranges define those limits between which the functionality of the device is guaranteed.

WARNING: The recommended operating conditions are required in order to ensure the normal operation of the semiconductor device. All of the device's electrical characteristics are warranted when the device is operated within these ranges.

Always use semiconductor devices within their recommended operating condition ranges. Operation outside these ranges may adversely affect reliability and could result in device failure.

No warranty is made with respect to uses, operating conditions, or combinations not represented on the data sheet. Users considering application outside the listed conditions are advised to contact their FUJITSU representatives beforehand.

■ DC CHARACTERISTICS

Parameter Symbol	Parameter Description	Test Conditions		Min.	Typ.	Max.	Unit	
I _{LI}	Input Leakage Current	—		-1.0	—	+1.0	μA	
I _{LO}	Output Leakage Current	—		-1.0	—	+1.0	μA	
I _{CC1f}	Flash V _{CC} Active Current (Read)	V _{CCf} = V _{CC} Max., \overline{CE} f = V _{IL} \overline{OE} = V _{IH}	t _{CYCLE} = 10 MHz t _{CYCLE} = 5 MHz	—	—	20 10	mA	
I _{CC2f}	Flash V _{CC} Active Current (Program/Erase)	V _{CCf} = V _{CC} Max., \overline{CE} f = V _{IL} , \overline{OE} = V _{IH}		—	—	35	mA	
I _{CC3f**}	Flash V _{CC} Active Current (Read-While-Program)	\overline{CE} = V _{IL} , \overline{OE} = V _{IH}		—	—	45	mA	
I _{CC4f**}	Flash V _{CC} Active Current (Read-While-Erase)	\overline{CE} = V _{IL} , \overline{OE} = V _{IH}		—	—	45	mA	
I _{CC5f}	Flash V _{CC} Active Current (Erase-Suspend-Program)	\overline{CE} = V _{IL} , \overline{OE} = V _{IH}		—	—	35	mA	
I _{CC1S}	SRAM V _{CC} Active Current	V _{CCS} = V _{CC} Max., \overline{CE} s = V _{IL}	t _{CYCLE} = min t _{CYCLE} = 1 MHz	—	—	60 12	mA	
I _{CC2S}	SRAM V _{CC} Active Current	\overline{CE} s = 0.2 V, WE = V _{CCS} - 0.2 V	t _{CYCLE} = min t _{CYCLE} = 1 MHz	—	—	50 6	mA	
I _{SB1f}	Flash V _{CC} Standby Current	V _{CCf} = V _{CC} Max., \overline{CE} f = V _{CCf} ± 0.3 V RESET = V _{CCf} ± 0.3 V		—	—	5	μA	
I _{SB2f}	Flash V _{CC} Standby Current (RESET)	V _{CCf} = V _{CC} Max., RESET = V _{SS} ± 0.3 V		—	—	5	μA	
I _{SB1S}	SRAM V _{CC} Standby Current	\overline{CE} s = V _{IH}		—	—	2	mA	
I _{SB2S}	SRAM V _{CC} Standby Current	\overline{CE} s = V _{CC} - 0.2 V	V _{CCS} = 3.0 V ± 10%	T _A = 25°C	—	1	2.5	μA
				T _A = -20 to +85°C	—	—	55	μA
			V _{CCS} = 3.3 V ± 0.3 V	T _A = 25°C	—	1.5	3	μA
				T _A = -20 to +85°C	—	—	60	μA
			V _{CCS} = 3.0 V	T _A = 25°C	—	1	2	μA
				T _A = -20 to +40°C	—	—	5	μA
			T _A = -20 to +85°C	—	—	50	μA	
V _{IL}	Input Low Level	—		-0.3	—	0.6	V	
V _{IH}	Input High Level	—		2.2	—	V _{CC} +0.3*	V	
V _{OL}	Output Low Voltage Level	I _{OL} = 2.1 mA, V _{CCf} = V _{CCS} = V _{CC} Min.		—	—	0.4	V	
V _{OH}	Output High Voltage Level	I _{OH} = -500 μA, V _{CCf} = V _{CCS} = V _{CC} Min.		V _{CC} -0.5	—	—	V	
V _{LKO}	Flash Low V _{CC} Lock-Out Voltage	—		2.3	—	2.5	V	

* : V_{CC} indicate lower of V_{CCf} or V_{CCS}

** : Embedded Algorithm (program or erase) is in progress. (@5 MHz)

MB84VD2008-10/MB84VD2009-10

■ AC CHARACTERISTICS

• CE Timing

Parameter Symbols		Description	Test Setup		-10	Unit
JEDEC	Standard					
—	t _{CCR}	CE Recover Time	—	Min.	0	ns

• Timing Diagram for alternating SRAM to Flash

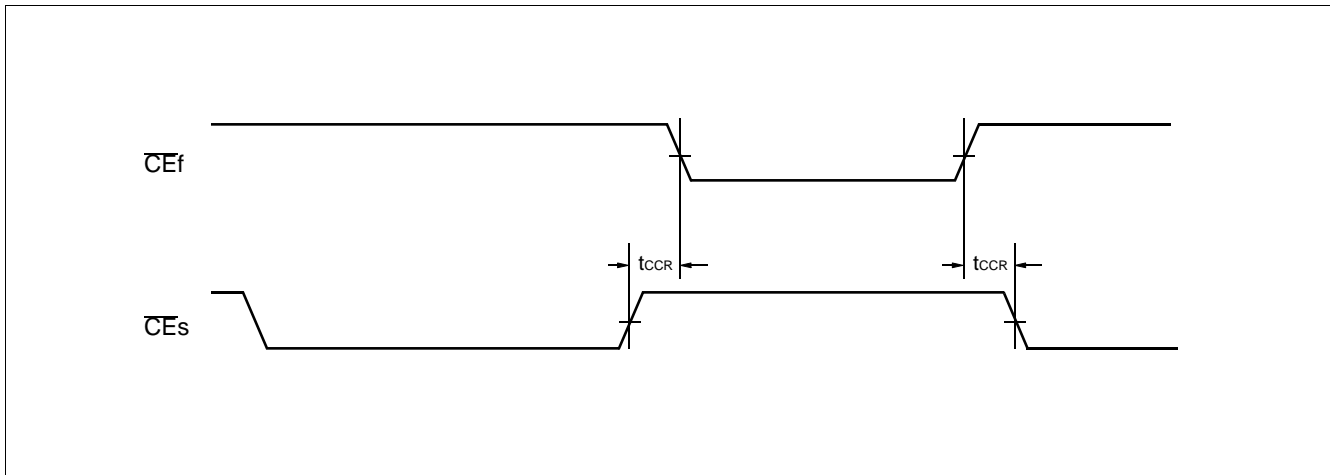

• Read Only Operations Characteristics (Flash)

Parameter Symbols		Description	Test Setup	-10 (Note)		Unit
JEDEC	Standard			Min.	Max.	
t _{AVAV}	t _{RC}	Read Cycle Time	—	100	—	ns
t _{AVQV}	t _{ACC}	Address to Output Delay	CEf = V _{IL} OE = V _{IL}	—	100	ns
t _{ELQV}	t _{CEf}	Chip Enable to Output Delay	OE = V _{IL}	—	100	ns
t _{GLQV}	t _{OE}	Output Enable to Output Delay	—	—	40	ns
t _{EHQZ}	t _{DF}	Chip Enable to Output High-Z	—	—	30	ns
t _{GHQZ}	t _{DF}	Output Enable to Output High-Z	—	—	30	ns
t _{AXQX}	t _{OH}	Output Hold Time From Addresses, CEf or OE, Whichever Occurs First	—	0	—	ns
—	t _{READY}	RESET Pin Low to Read Mode	—	—	20	μs
—	t _{ELFL} t _{ELFH}	CE or BYTE Switching Low or High	—	—	5	ns

Note: Test Conditions—Output Load: 1 TTL gate and 30 pF
 Input rise and fall times: 5 ns
 Input pulse levels: 0.0 V to 3.0 V
 Timing measurement reference level
 Input: 1.5 V
 Output: 1.5 V

• Read Cycle (Flash)

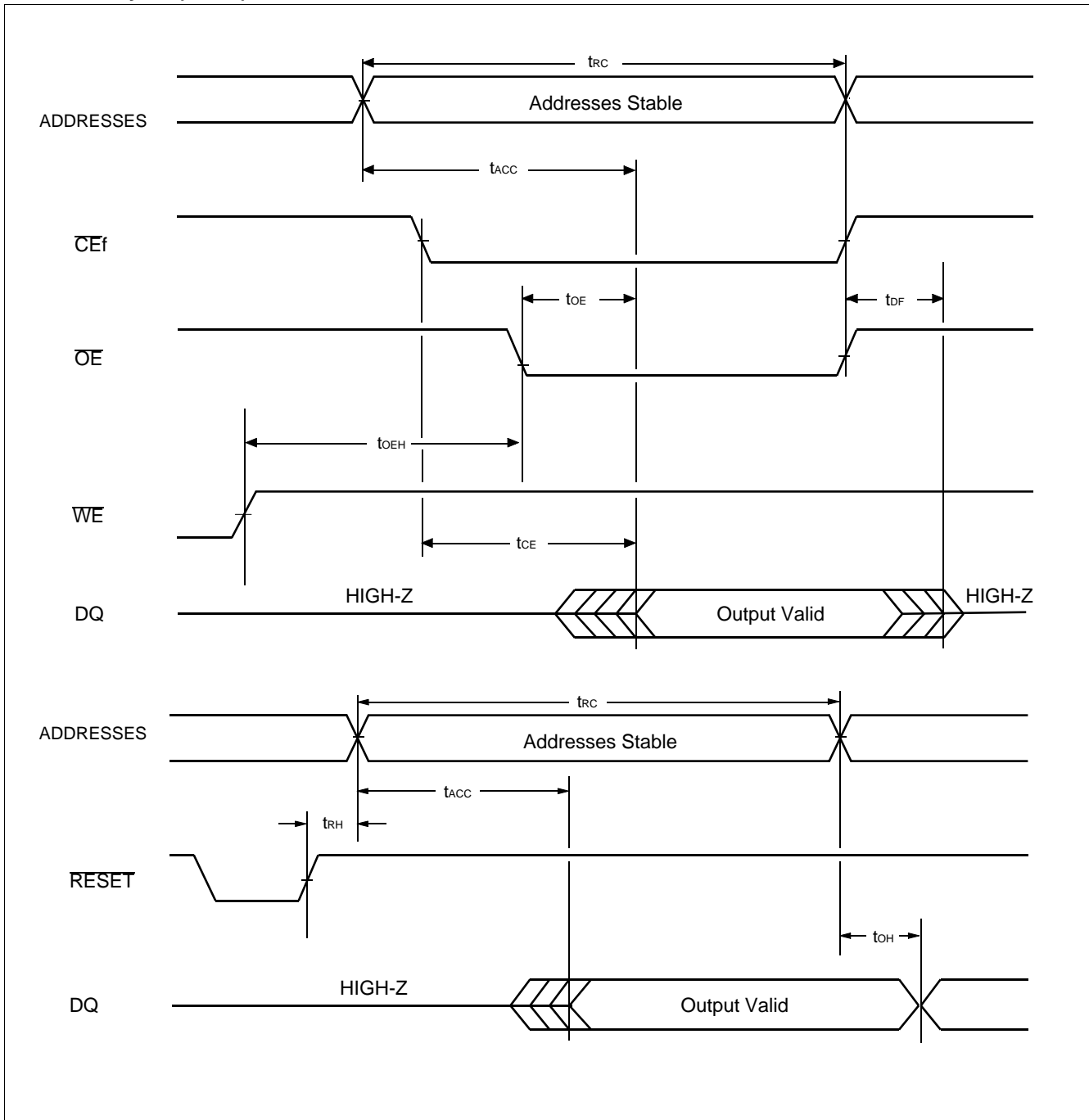

MB84VD2008-10/MB84VD2009-10

• Erase/Program Operations (Flash)

Parameter Symbols		Description	-10			Unit
JEDEC	Standard		Min.	Typ.	Max.	
t _{AVAV}	t _{WC}	Write Cycle Time	100	—	—	ns
t _{AVWL}	t _{AS}	Address Setup Time (\overline{WE} to Addr.)	0	—	—	ns
t _{AVEL}	t _{AS}	Address Setup Time (\overline{CEf} to Addr.)	0	—	—	ns
—	t _{ASO}	Address Setup Time to \overline{OE} Low During Toggle Bit Polling	15	—	—	ns
t _{WLAX}	t _{AH}	Address Hold Time (\overline{WE} to Addr.)	50	—	—	ns
t _{ELAX}	t _{AH}	Address Hold Time (\overline{CEf} to Addr.)	50	—	—	ns
—	t _{AHT}	Address Hold Time from \overline{CE} or \overline{OE} High During Toggle Bit Polling	0	—	—	ns
t _{DVWH}	t _{DS}	Data Setup Time	50	—	—	ns
t _{WHDX}	t _{DH}	Data Hold Time	0	—	—	ns
—	t _{OEH}	Output Enable Hold Time	0	—	—	ns
		Read Toggle and \overline{Data} Polling	10	—	—	ns
—	t _{CEPH}	\overline{CE} High During Toggle Bit Polling	20	—	—	ns
—	t _{OEPH}	\overline{OE} High During Toggle Bit Polling	20	—	—	ns
t _{GHEL}	t _{GHEL}	Read Recover Time Before Write (\overline{OE} to \overline{CEf})	0	—	—	ns
t _{GHWL}	t _{GHWL}	Read Recover Time Before Write (\overline{OE} to \overline{WE})	0	—	—	ns
t _{WLEL}	t _{WS}	\overline{WE} Setup Time (\overline{CEf} to \overline{WE})	0	—	—	ns
t _{ELWL}	t _{CS}	\overline{CEf} Setup Time (\overline{WE} to \overline{CEf})	0	—	—	ns
t _{EHWH}	t _{WH}	\overline{WE} Hold Time (\overline{CEf} to \overline{WE})	0	—	—	ns
t _{WHEH}	t _{CH}	\overline{CEf} Hold Time (\overline{WE} to \overline{CEf})	0	—	—	ns
t _{WLWH}	t _{WP}	Write Pulse Width	50	—	—	ns
t _{LELH}	t _{CP}	\overline{CEf} Pulse Width	50	—	—	ns
t _{WHWL}	t _{WPH}	Write Pulse Width High	30	—	—	ns
t _{EHEL}	t _{CPH}	\overline{CEf} Pulse Width High	30	—	—	ns
t _{WHWH1}	t _{WHWH1}	Byte Programming Operation	—	8	—	μs
t _{WHWH2}	t _{WHWH2}	Sector Erase Operation (Note 1)	—	1	—	sec
			—	—	15	sec
—	t _{VCS}	V _{ccf} Setup Time	50	—	—	μs
—	t _{VLHT}	Voltage Transition Time (Note 2)	4	—	—	μs
—	t _{VIDR}	Rise Time to V _{ID} (Note 2)	500	—	—	ns
—	t _{RB}	Recover Time from RY/BY	0	—	—	ns
—	t _{RP}	RESET Pulse Width	500	—	—	ns
—	t _{RH}	RESET Hold Time Before Read	200	—	—	ns
—	t _{EOE}	Delay Time from Embedded Output Enable	—	—	100	ns
—	t _{BUSY}	Program/Erase Valid to RY/BY Delay	—	—	90	ns
—	t _{FLQZ}	BYTE Switching Low to Output High-Z	—	—	30	ns
—	t _{FHQV}	BYTE Switching High to Output Active	30	—	—	ns

Note : 1. This does not include the preprogramming time.

2. This timing is for Sector Protection Operation.

• Write Cycle (WE control) (Flash)

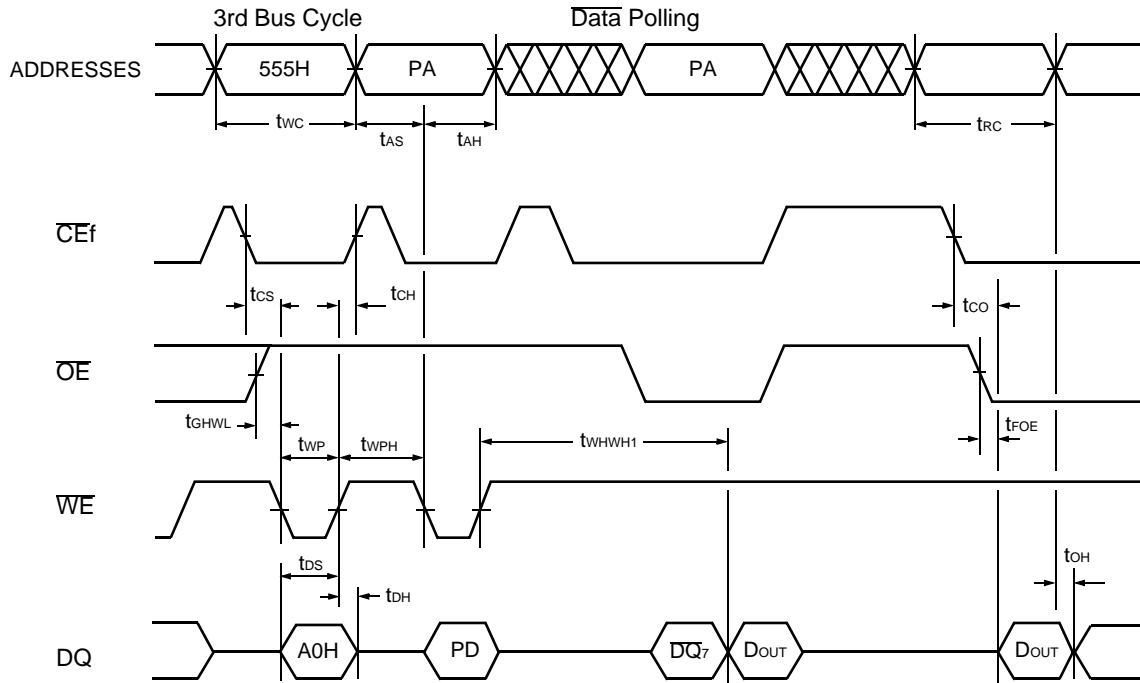

- Notes:**
1. PA is address of the memory location to be programmed.
 2. PD is data to be programmed at byte address.
 3. \overline{DQ}_7 is the output of the complement of the data written to the device.
 4. D_{OUT} is the output of the data written to the device.
 5. Figure indicates last two bus cycles out of four cycle sequence
 6. These waveforms are for the x16 mode. The addresses differ from x8 mode.

MB84VD2008-10/MB84VD2009-10

• Write Cycle (\overline{CEf} control) (Flash)

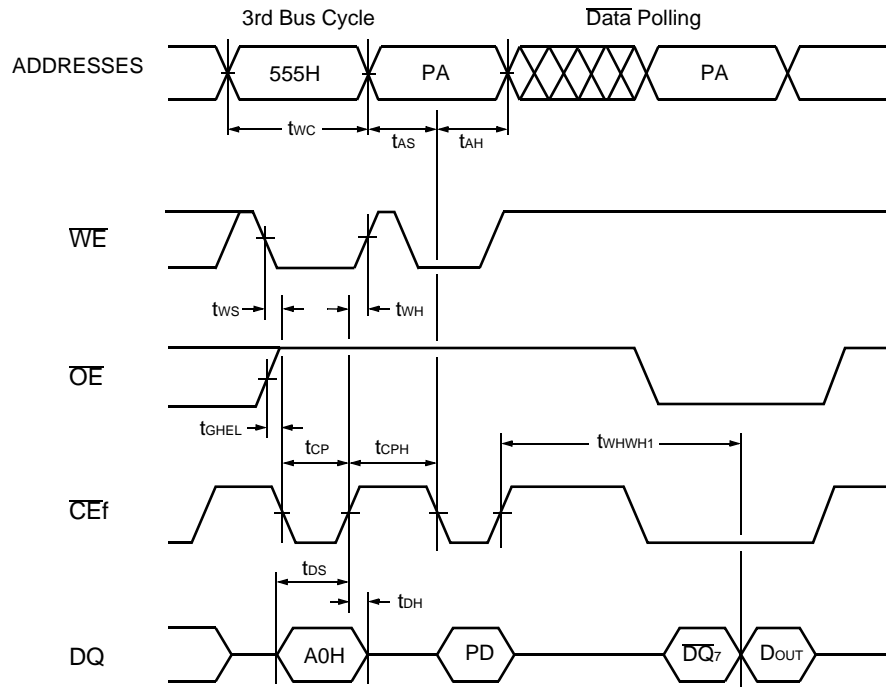

- Notes:**
1. PA is address of the memory location to be programmed.
 2. PD is data to be programmed at byte address.
 3. \overline{DQ}_7 is the output of the complement of the data written to the device.
 4. D_{OUT} is the output of the data written to the device.
 5. Figure indicates last two bus cycles out of four bus cycle sequence
 6. These waveforms are for the x16 mode. The addresses differ from x8 mode.

• AC Waveforms Chip/Sector Erase Operations (Flash)

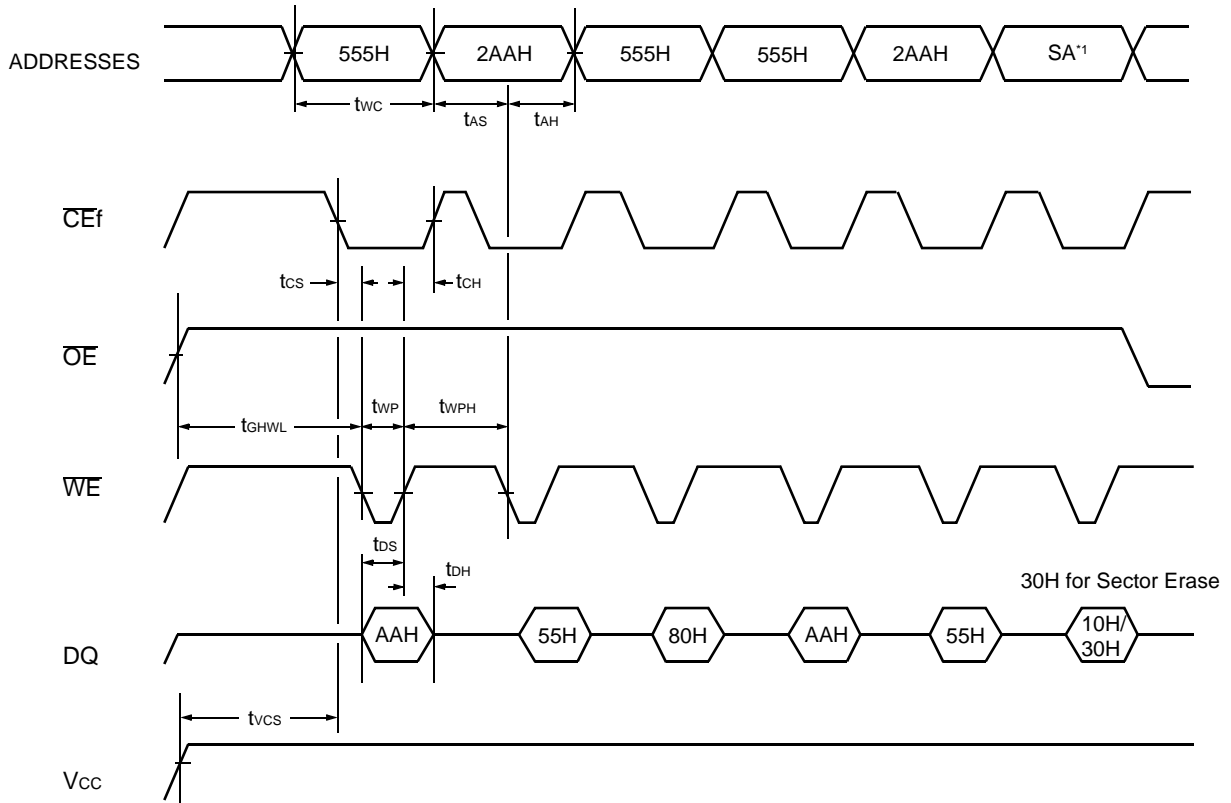

- Notes:**
1. SA is the sector address for Sector Erase. Addresses = 555H for Chip Erase.
 2. These waveforms are for the x16 mode. The addresses differ from x8 mode.

MB84VD2008-10/MB84VD2009-10

• AC Waveforms for Data Polling during Embedded Algorithm Operations (Flash)

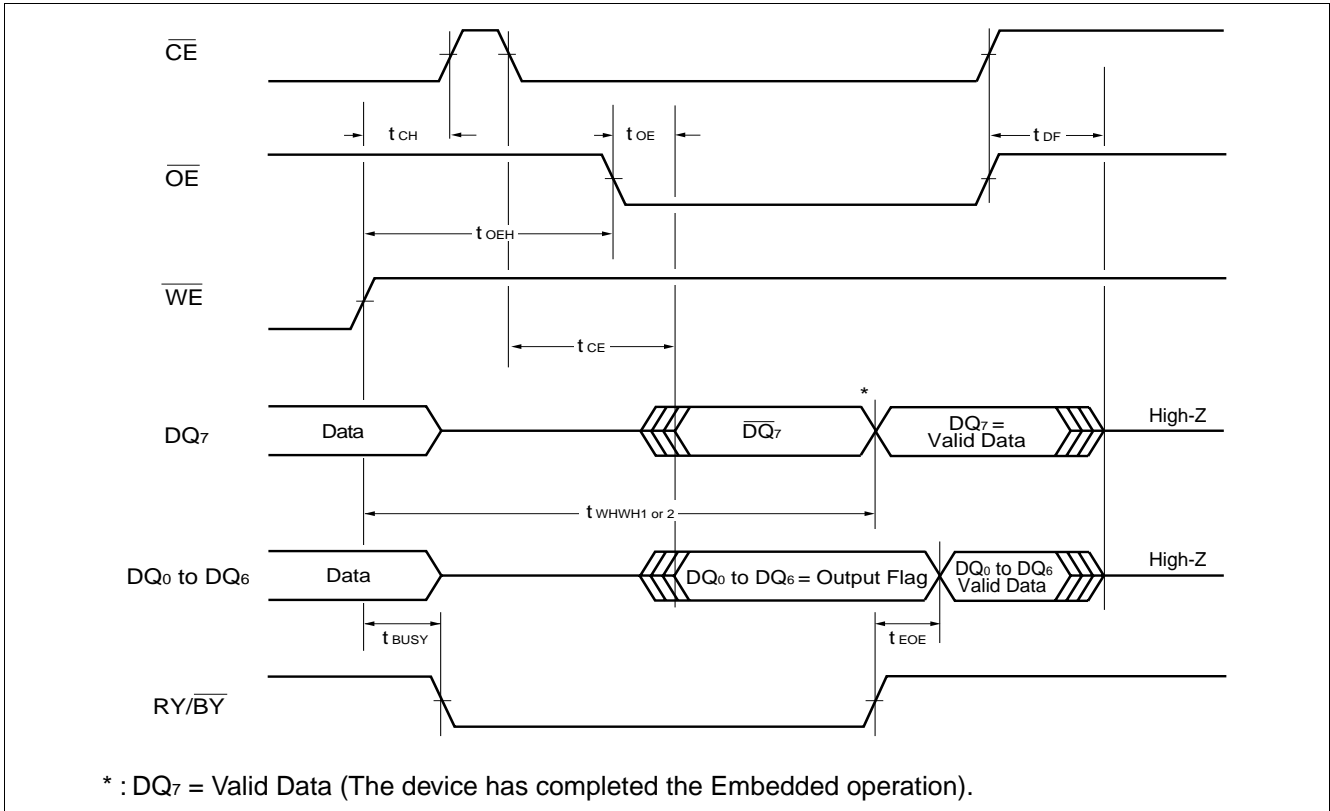

• AC Waveforms for Toggle Bit during Embedded Algorithm Operations (Flash)

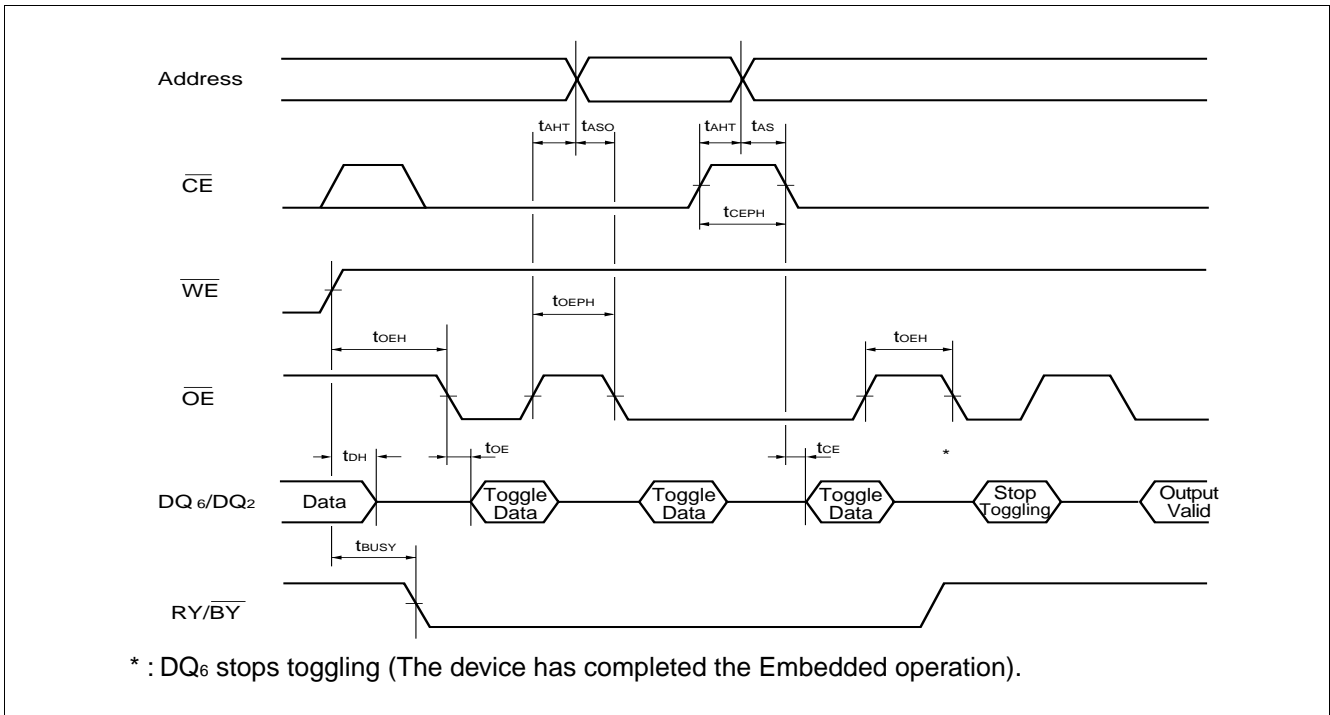

• RY/BY Timing Diagram during Write/Erase Operations (Flash)

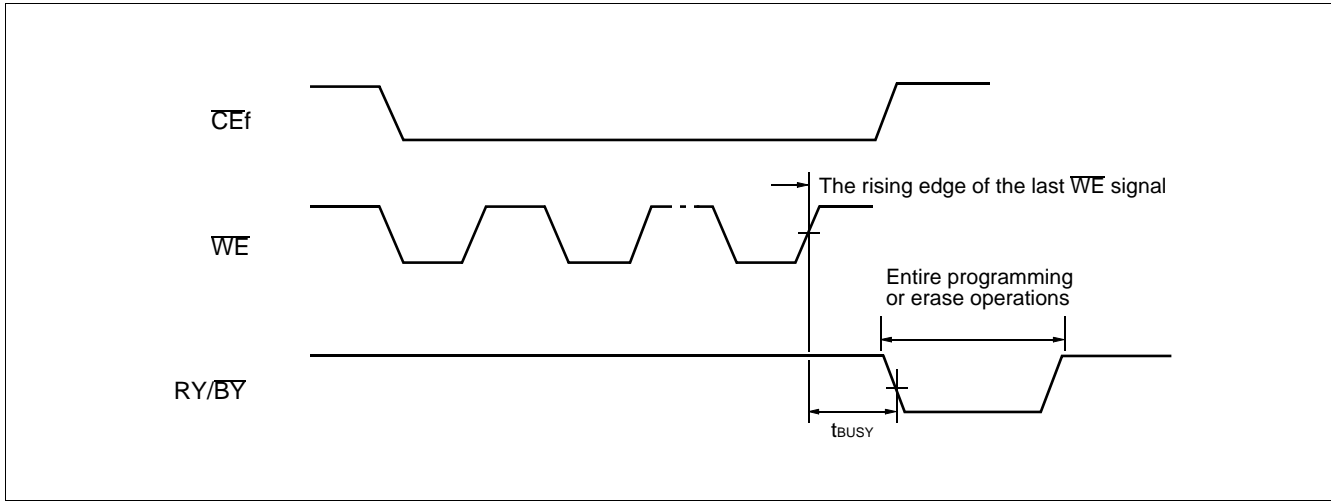

• RESET, RY/BY Timing Diagram (Flash)

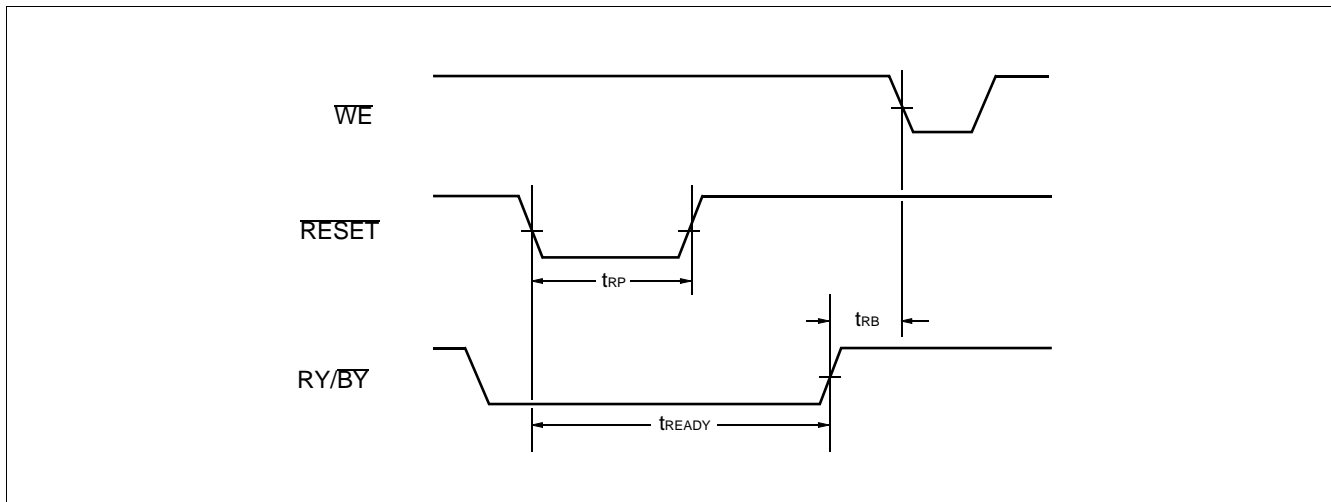

• Timing Diagram for Word Mode Configuration (Flash)

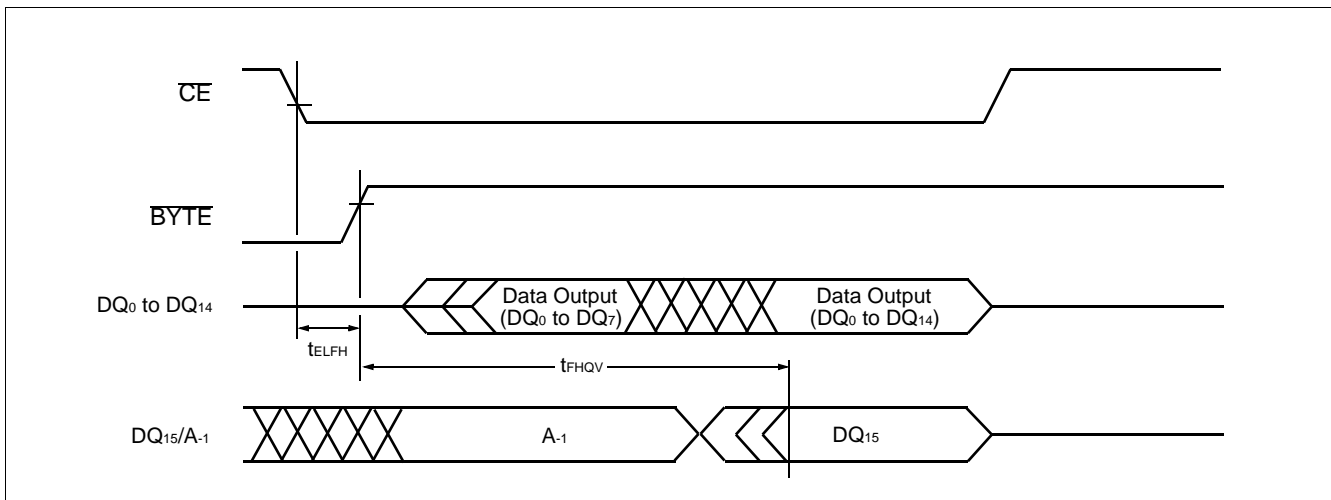

MB84VD2008-10/MB84VD2009-10

• Timing Diagram for Byte Mode Configuration (Flash)

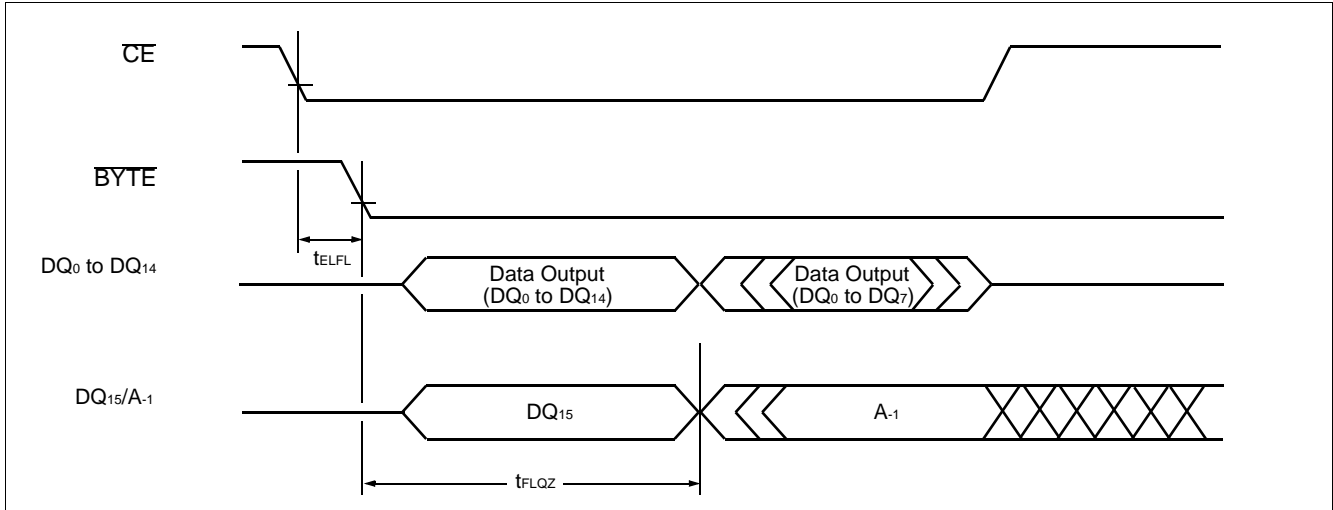

• BYTE Timing Diagram for Write Operations (Flash)

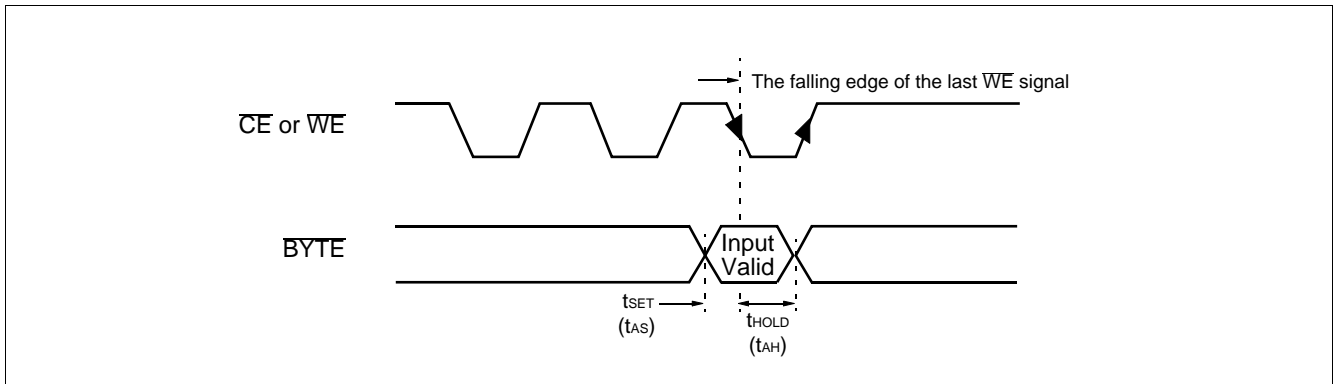

• Temporary Sector Unprotection (Flash)

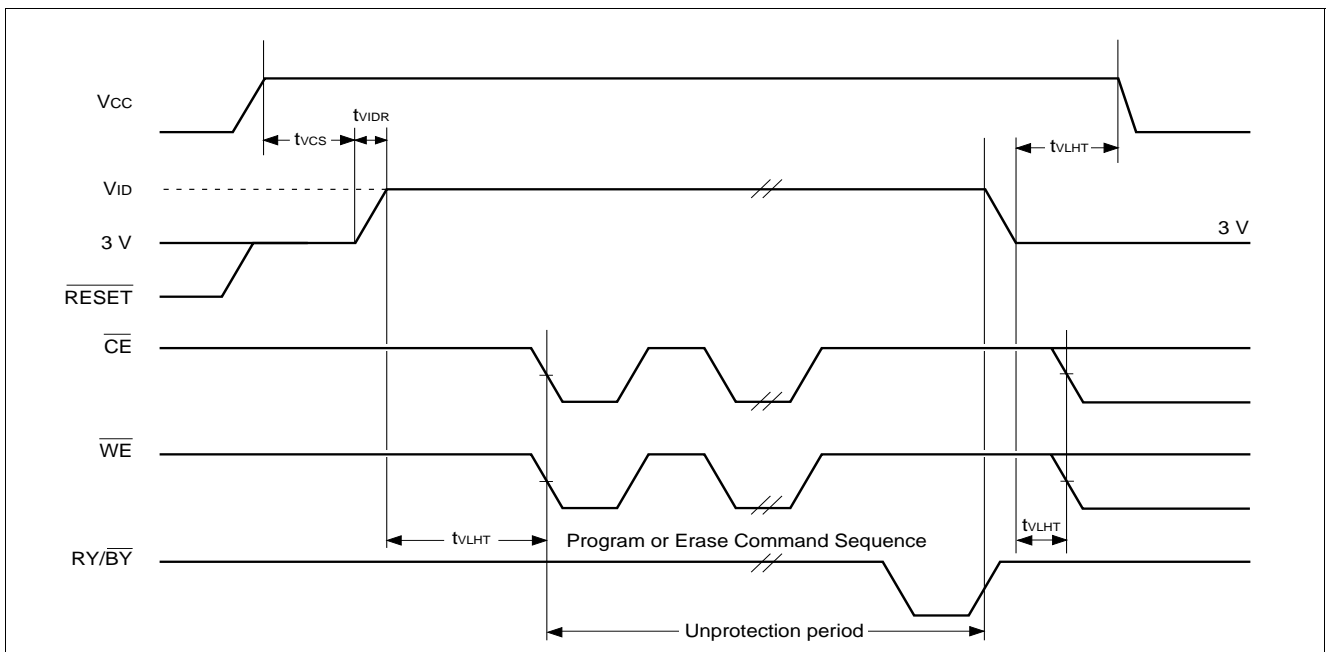

• Back-to-back Read/Write Timing Diagram

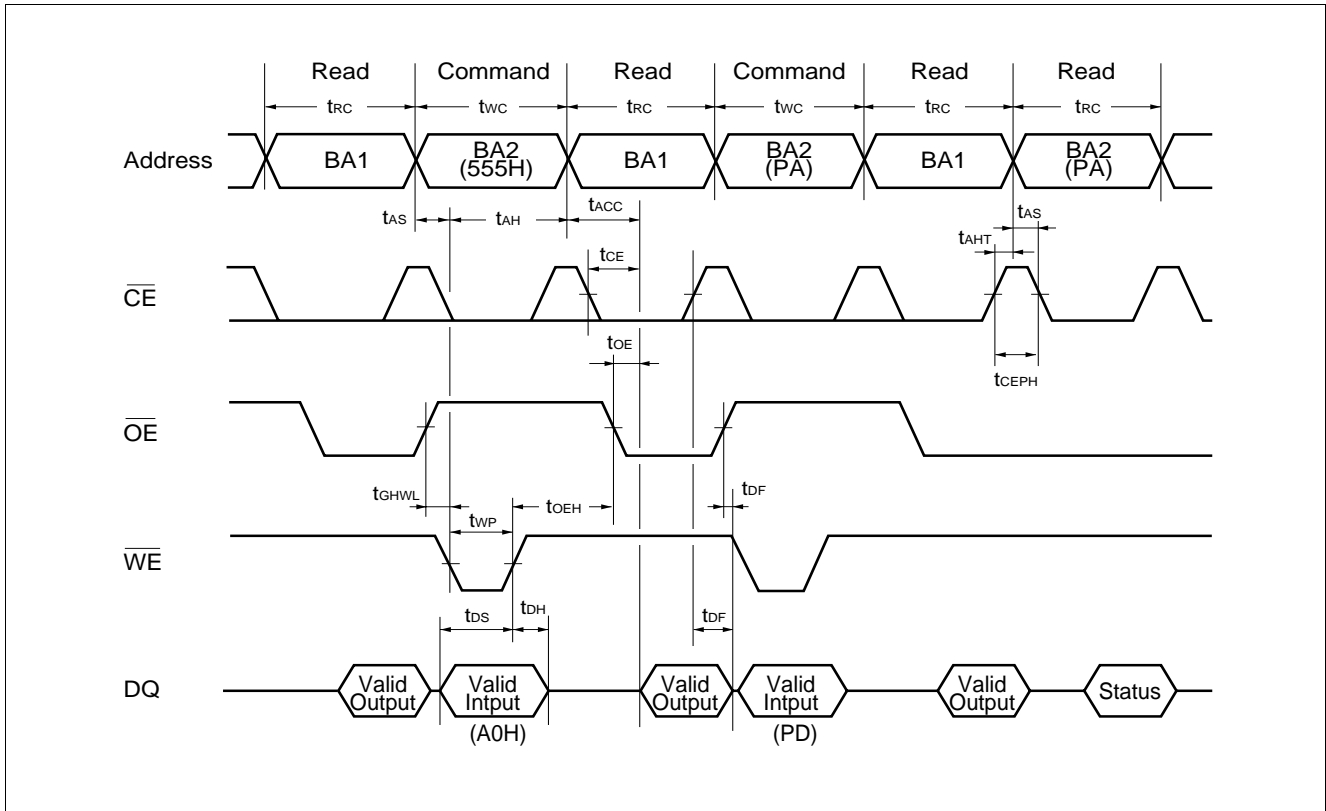

• Extended Sector Protection (Flash)

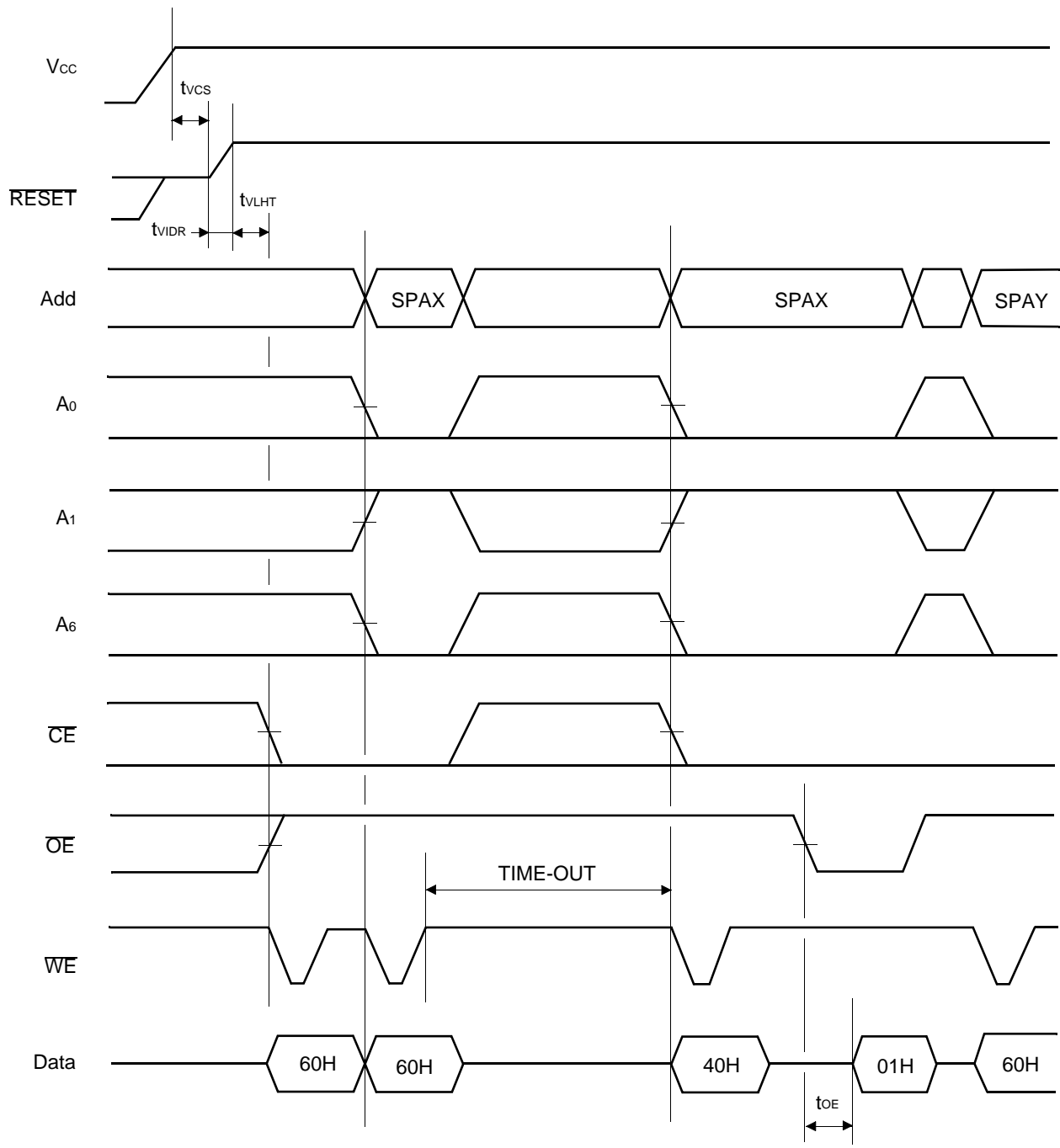

SPAX : Sector Address to be protected
 SPAY : Next Sector Address to be protected
 TIME-OUT : Time-Out window = 150 μs (min)

• Read Cycle (SRAM)

Parameter Symbol	Parameter Description	Min.	Max.	Unit
t _{RC}	Read Cycle Time	85	—	ns
t _{AA}	Address Access Time	—	85	ns
t _{CO}	Chip Enable (\overline{CE} s) Access Time	—	85	ns
t _{OE}	Output Enable Access Time	—	45	ns
t _{BA}	\overline{UB} , \overline{LB} Access Time	—	45	ns
t _{COE}	Chip Enable Low to Output Active	5	—	ns
t _{OEE}	Output Enable Low to Output Active	0	—	ns
t _{BE}	\overline{UB} , \overline{LB} Low to Output Active	0	—	ns
t _{OD}	Chip Enable High to Output High-Z	—	35	ns
t _{ODO}	Output Enable High to Output High-Z	—	35	ns
t _{BD}	\overline{UB} , \overline{LB} High to Output High-Z	—	35	ns
t _{OH}	Output Data Hold Time	10	—	ns

• Read Cycle (Note 1) (SRAM)

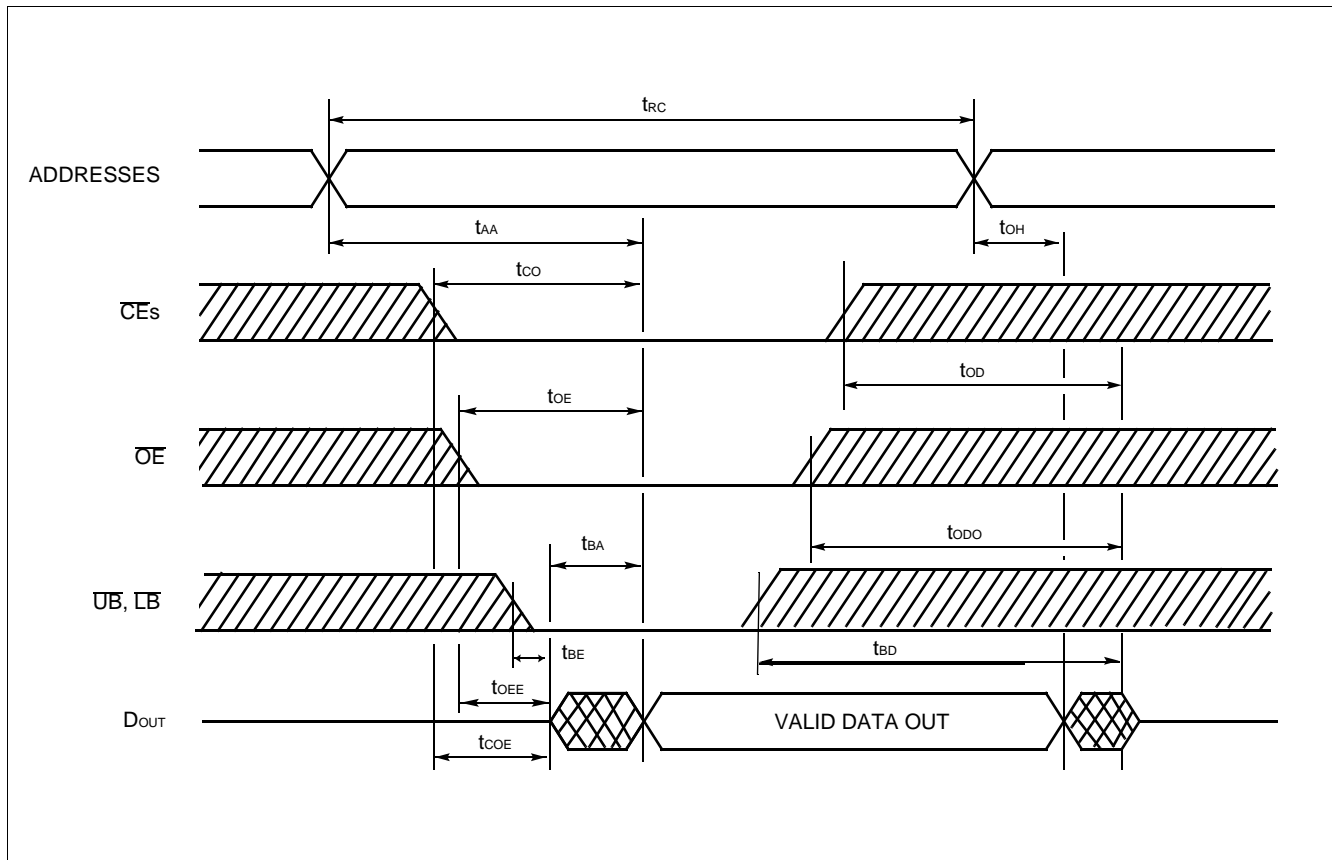

Note: 1. \overline{WE} remains HIGH for the read cycle.

MB84VD2008-10/MB84VD2009-10

• Write Cycle (SRAM)

Parameter Symbol	Parameter Description	Min.	Max.	Unit
t_{WC}	Write Cycle Time	85	—	ns
t_{WP}	Write Pulse Width	60	—	ns
t_{CW}	Chip Enable to End of Write	75	—	ns
$t_{\overline{UB}, \overline{LB}}$	$\overline{UB}, \overline{LB}$ Valid to End of Write	55	—	ns
t_{AS}	Address Setup Time	0	—	ns
t_{WR}	Write Recovery Time	0	—	ns
t_{ODW}	\overline{WE} Low to Output High-Z	—	35	ns
t_{OEW}	\overline{WE} High to Output Active	0	—	ns
t_{DS}	Data Setup Time	35	—	ns
t_{DH}	Data Hold Time	0	—	ns

• Write Cycle (Note 4) (\overline{WE} control) (SRAM)

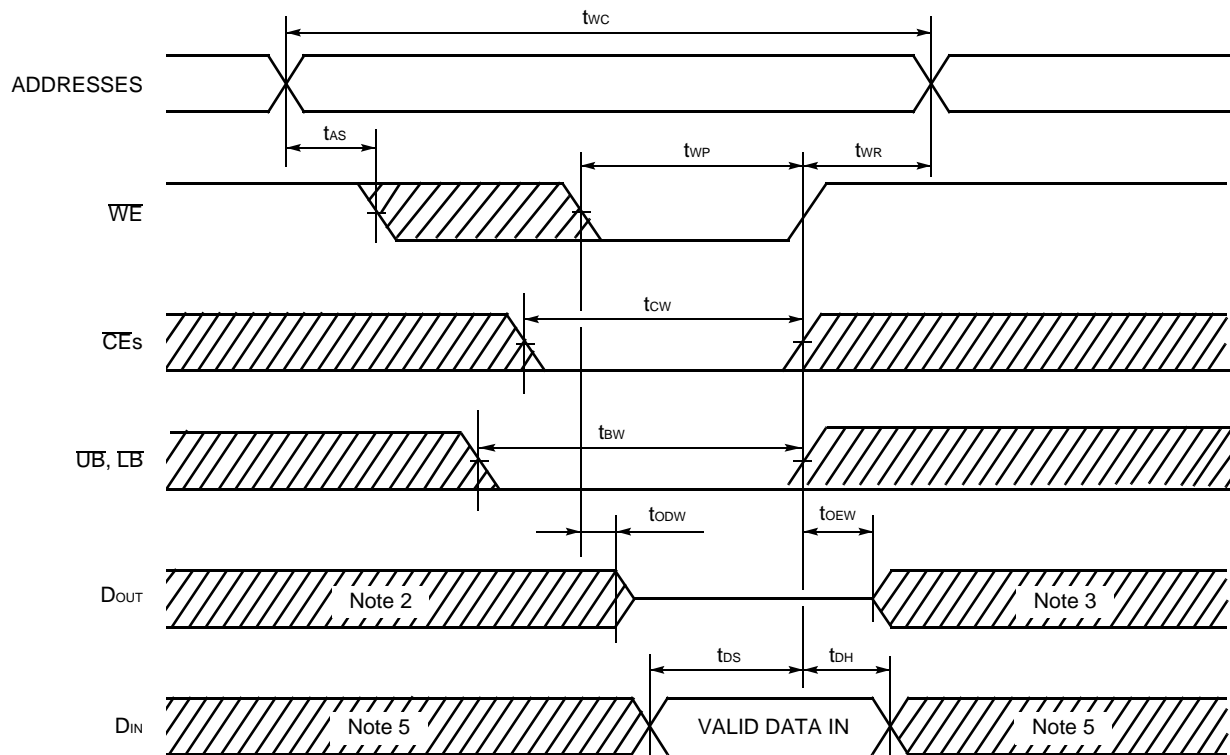

- Notes:**
2. If \overline{CEs} goes LOW coincident with or after \overline{WE} goes LOW, the output will remain at high impedance.
 3. If \overline{CEs} goes HIGH coincident with or before \overline{WE} goes HIGH, the output will remain at high impedance.
 4. If \overline{OE} is HIGH during the write cycle, the outputs will remain at high impedance.
 5. Because I/O signals may be in the output state at this Time, input signals of reverse polarity must not be applied.

• Write Cycle (Note 4) (\overline{CE} s control) (SRAM)

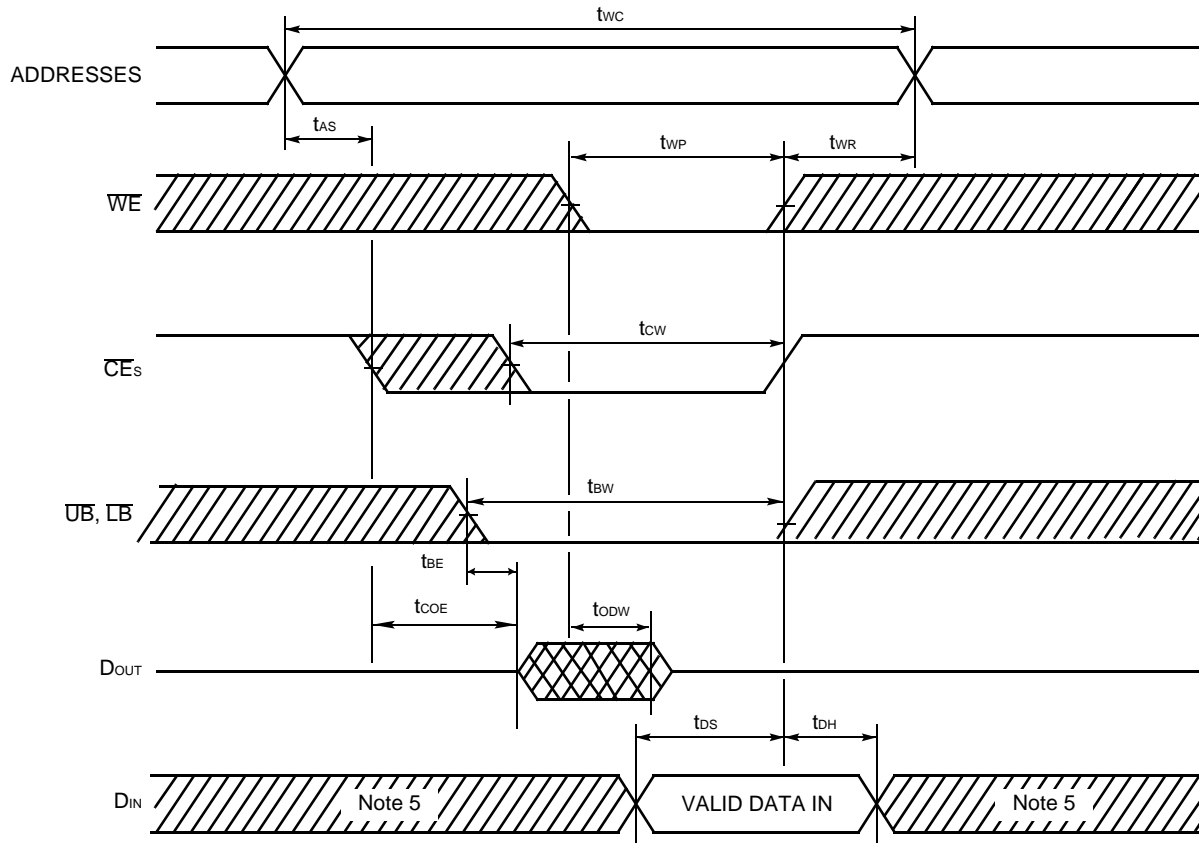

- Notes:**
2. If \overline{CE}_s goes LOW coincident with or after \overline{WE} goes LOW, the output will remain at high impedance.
 3. If \overline{CE}_s goes HIGH coincident with or before \overline{WE} goes HIGH, the output will remain at high impedance.
 4. If \overline{OE} is HIGH during the write cycle, the outputs will remain at high impedance.
 5. Because I/O signals may be in the output state at this Time, input signals of reverse polarity must not be applied.

MB84VD2008-10/MB84VD2009-10

• Write Cycle (Note 4) (\overline{UB} , \overline{LB} Control) (SRAM)

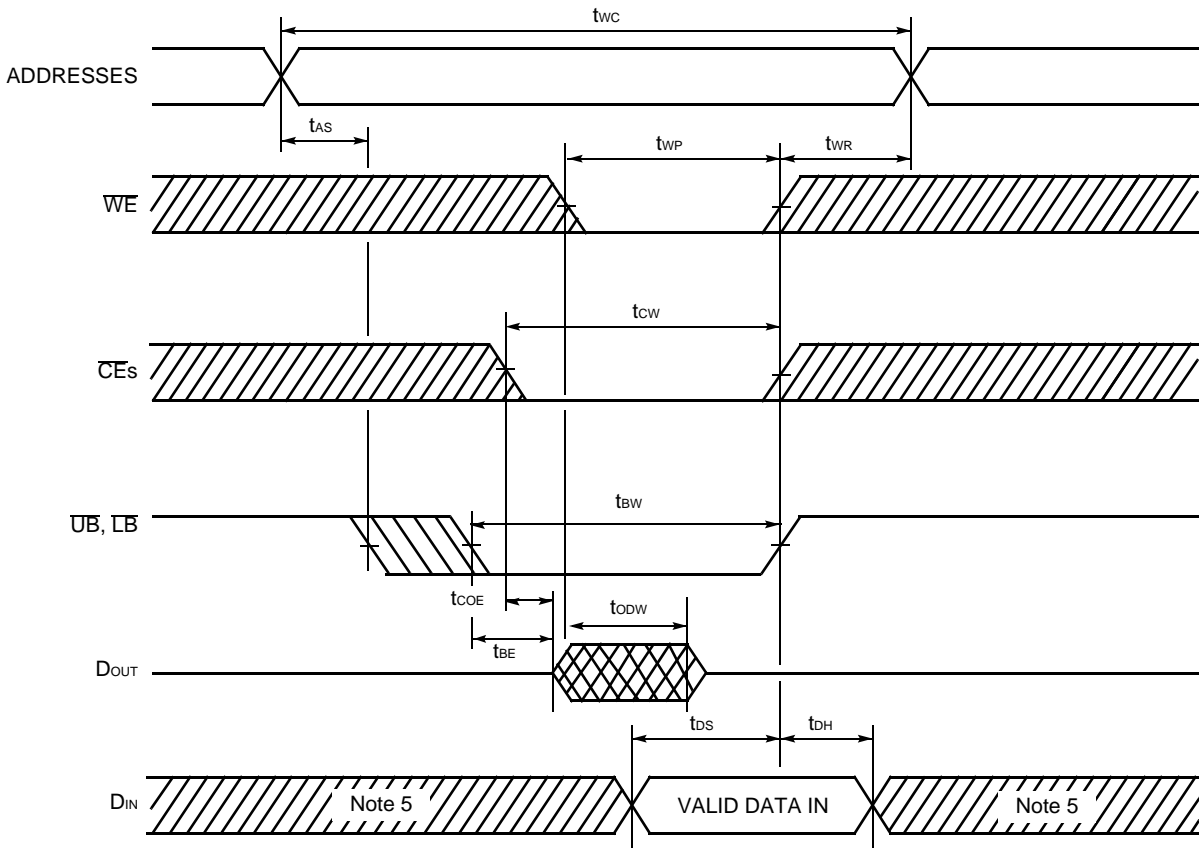

- Notes:**
2. If \overline{CEs} goes LOW coincident with or after \overline{WE} goes LOW, the output will remain at high impedance.
 3. If \overline{CEs} goes HIGH coincident with or before \overline{WE} goes HIGH, the output will remain at high impedance.
 4. If \overline{OE} is HIGH during the write cycle, the outputs will remain at high impedance.
 5. Because I/O signals may be in the output state at this Time, input signals of reverse polarity must not be applied.

■ ERASE AND PROGRAMMING PERFORMANCE (Flash)

Parameter	Limits			Unit	Comment
	Min.	Typ.	Max.		
Sector Erase Time	—	1	10	sec	Excludes programming time prior to erasure
Byte Programming Time	—	8	300	μs	Excludes system-level overhead
Word Programming Time	—	16	360	μs	
Chip Programming Time	—	8.4	TBD	sec	Excludes system-level overhead
Erase/Program Cycle	100,000	—	—	cycles	

■ DATA RETENTION CHARACTERISTICS (SRAM)

Parameter Symbol	Parameter Description	Min.	Typ.	Max.	Unit
V_{DH}	Data Retention Supply Voltage	2.0	—	3.6	V
I_{DDS2}	Standby Current	—	—	50*	μA
t_{CDR}	Chip Deselect to Data Retention Mode Time	0	—	—	ns
t_R	Recovery Time	5	—	—	ms

* : 5 μA (Max.) at $T_A = -20^{\circ}\text{C}$ to $+40^{\circ}\text{C}$

• $\overline{\text{CE}}_1$ s Controlled Data Retention Mode

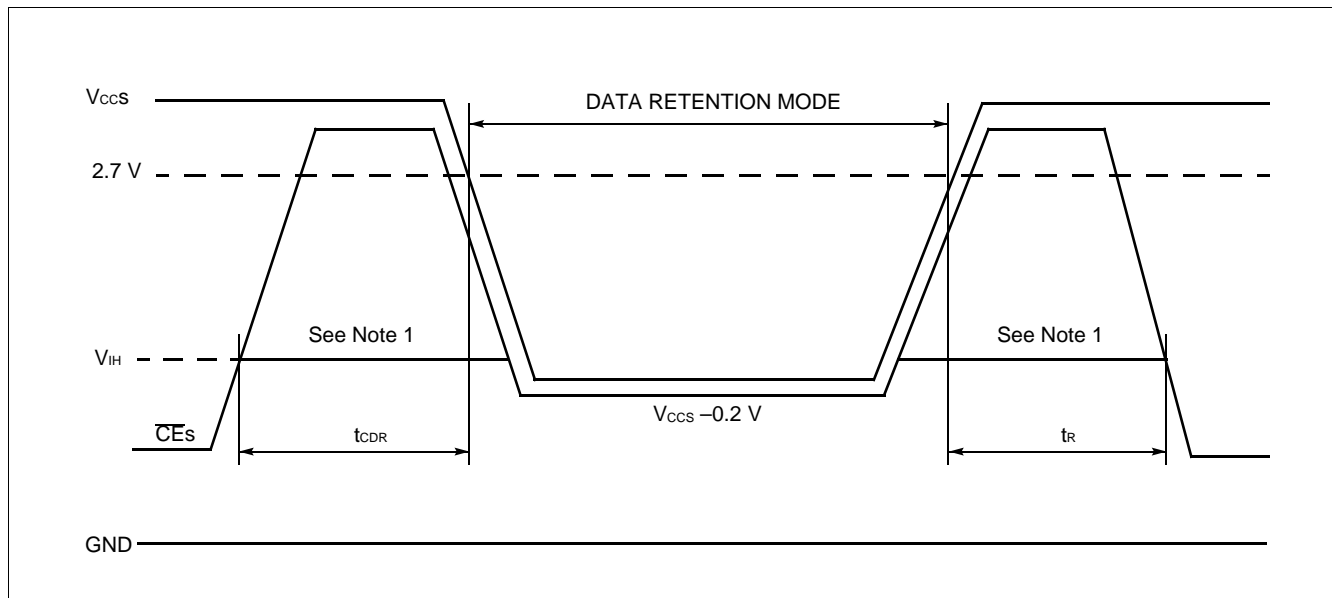

Notes:1.) When $\overline{\text{CE}}_1$ is operating at the V_{IH} min. level (2.2 V), the standby current is given by I_{SB1S} during the transition of V_{CCS} from 3.6 to 2.2 V.

■ PIN CAPACITANCE

Parameter Symbol	Parameter Description	Test Setup	Typ.	Max.	Unit
C _{IN}	Input Capacitance	V _{IN} = 0	TBD	TBD	pF
C _{OUT}	Output Capacitance	V _{OUT} = 0	TBD	TBD	pF
C _{IN2}	Control Pin Capacitance	V _{IN} = 0	TBD	TBD	pF

Note: Test conditions T_A = 25°C, f = 1.0 MHz

■ HANDRING OF PACKAGE

Please handle this package carefully since the sides of packages are right angle.

■ CAUTION

- 1.)The high voltage (VID) can not apply to address pins and control pins except **RESET**. Therefore, it can not use autoselect and sector protect function by applying the high voltage (VID) to specific pins.
- 2.)For the sector protection, since the high voltage (VID) can be applied to the **RESET**, it can be protected the sector useing "Extended sector protect" command.

MB84VD2008-10/MB84VD2009-10

■ PACKAGE

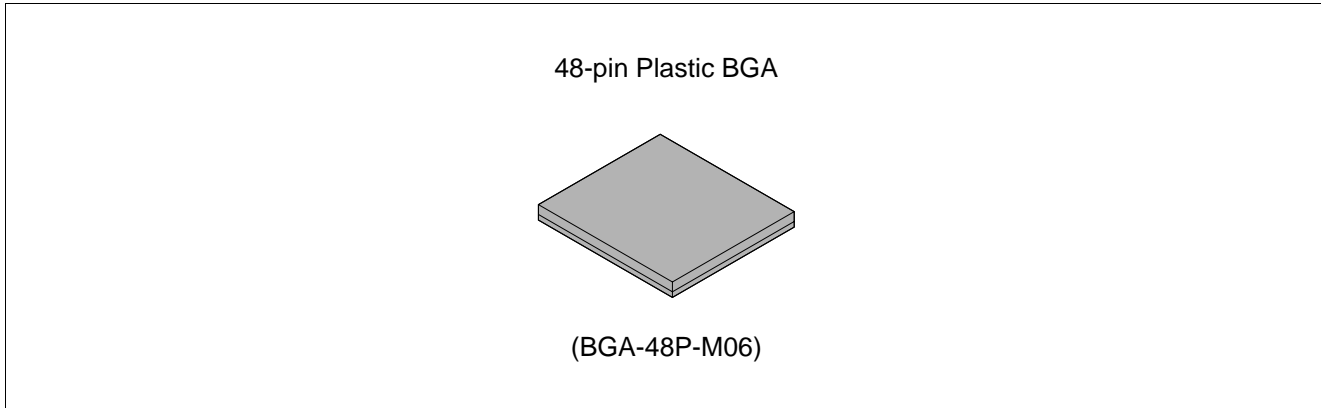

■ PACKAGE DIMENSIONS

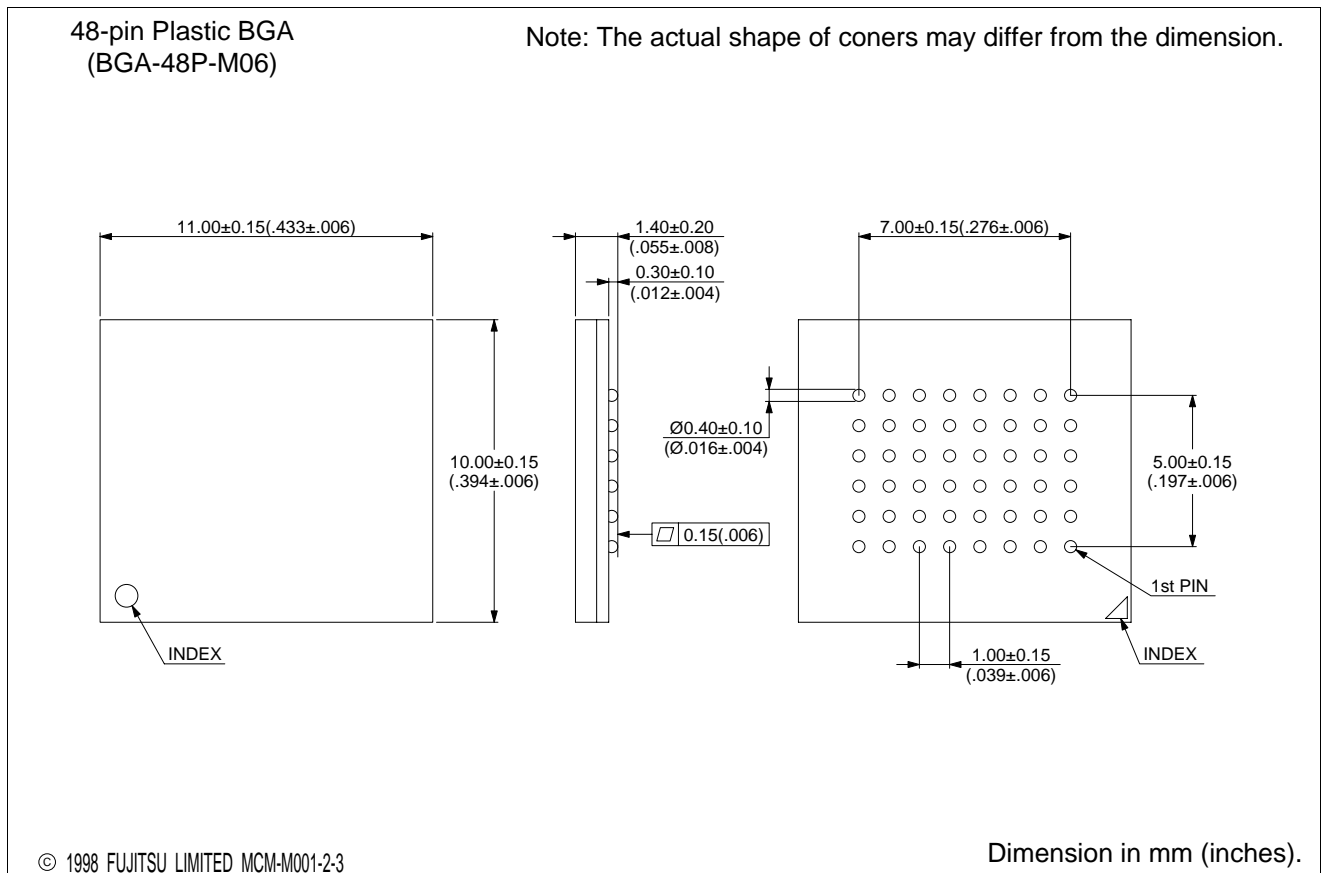

FUJITSU LIMITED

For further information please contact:

Japan

FUJITSU LIMITED
Corporate Global Business Support Division
Electronic Devices
KAWASAKI PLANT, 4-1-1, Kamikodanaka
Nakahara-ku, Kawasaki-shi
Kanagawa 211-8588, Japan
Tel: (044) 754-3763
Fax: (044) 754-3329

<http://www.fujitsu.co.jp/>

North and South America

FUJITSU MICROELECTRONICS, INC.
Semiconductor Division
3545 North First Street
San Jose, CA 95134-1804, USA
Tel: (408) 922-9000
Fax: (408) 922-9179

Customer Response Center
Mon. - Fri.: 7 am - 5 pm (PST)
Tel: (800) 866-8608
Fax: (408) 922-9179

<http://www.fujitsumicro.com/>

Europe

FUJITSU MIKROELEKTRONIK GmbH
Am Siebenstein 6-10
D-63303 Dreieich-Buchsschlag
Germany
Tel: (06103) 690-0
Fax: (06103) 690-122

<http://www.fujitsu-edc.com/>

Asia Pacific

FUJITSU MICROELECTRONICS ASIA PTE LTD
#05-08, 151 Lorong Chuan
New Tech Park
Singapore 556741
Tel: (65) 281-0770
Fax: (65) 281-0220

<http://www.fmap.com.sg/>

F9806

© FUJITSU LIMITED Printed in Japan

All Rights Reserved.

The contents of this document are subject to change without notice. Customers are advised to consult with FUJITSU sales representatives before ordering.

The information and circuit diagrams in this document are presented as examples of semiconductor device applications, and are not intended to be incorporated in devices for actual use. Also, FUJITSU is unable to assume responsibility for infringement of any patent rights or other rights of third parties arising from the use of this information or circuit diagrams.

FUJITSU semiconductor devices are intended for use in standard applications (computers, office automation and other office equipment, industrial, communications, and measurement equipment, personal or household devices, etc.).

CAUTION:

Customers considering the use of our products in special applications where failure or abnormal operation may directly affect human lives or cause physical injury or property damage, or where extremely high levels of reliability are demanded (such as aerospace systems, atomic energy controls, sea floor repeaters, vehicle operating controls, medical devices for life support, etc.) are requested to consult with FUJITSU sales representatives before such use. The company will not be responsible for damages arising from such use without prior approval.

Any semiconductor devices have an inherent chance of failure. You must protect against injury, damage or loss from such failures by incorporating safety design measures into your facility and equipment such as redundancy, fire protection, and prevention of over-current levels and other abnormal operating conditions.

If any products described in this document represent goods or technologies subject to certain restrictions on export under the Foreign Exchange and Foreign Trade Law of Japan, the prior authorization by Japanese government will be required for export of those products from Japan.