

Stacked MCP (Multi-Chip Package) FLASH MEMORY & SRAM
CMOS

32M (× 8/×16) FLASH MEMORY & 2M (× 8/×16) STATIC RAM

MB84VD2208XEA-90/MB84VD2209XEA-90

■ FEATURES

- Power supply voltage of 2.7 to 3.3V
- High performance
90 ns maximum access time (Flash)
85 ns maximum access time (SRAM)
- Operating Temperature
-25 to +85°C
- Package 73-ball FBGA

(Continued)

■ PRODUCT LINE UP

| | | Flash Memory | SRAM |
|---------------------------------------|---|-----------------------------------|------|
| Ordering Part No. | $V_{ccf}, V_{ccs} = 3.0 V \begin{smallmatrix} +0.3 V \\ -0.3 V \end{smallmatrix}$ | MB84VD2208XEA-90/MB84VD2209XEA-90 | |
| Max. Address Access Time (ns) | | 90 | 85 |
| Max. \overline{CE} Access Time (ns) | | 90 | 85 |
| Max. \overline{OE} Access Time (ns) | | 40 | 45 |

■ PACKAGE

73-ball plastic FBGA

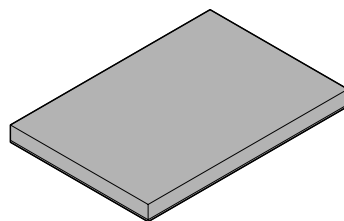

(BGA-73P-M01)

(Continued)

1. FLASH MEMORY

- **Simultaneous Read/Write operations (dual bank)**
Multiple devices available with different bank sizes
Host system can program or erase in one bank, then immediately and simultaneously read from the other bank
Zero latency between read and write operations
Read-while-erase
Read-while-program
- **Minimum 100,000 write/erase cycles**
- **Sector erase architecture**
Eight 4 K words and sixty three 32 K words.
Any combination of sectors can be concurrently erased. Also supports full chip erase.
- **Boot Code Sector Architecture**
MB84VD2208XEA: Top sector
MB84VD2209XEA: Bottom sector
- **Embedded Erase™ Algorithms**
Automatically pre-programs and erases the chip or any sector
- **Embedded Program™ Algorithms**
Automatically writes and verifies data at specified address
- **Data Polling and Toggle Bit feature for detection of program or erase cycle completion**
- **Ready-Busy output (RY/BY)**
Hardware method for detection of program or erase cycle completion
- **Automatic sleep mode**
When addresses remain stable, automatically switch themselves to low power mode.
- **Low V_{ccf} write inhibit ≤ 2.5 V**
- **Hidden ROM (Hi-ROM) region**
64K byte of Hi-ROM, accessible through a new “Hi-ROM Enable” command sequence
Factory serialized and protected to provide a secure electronic serial number (ESN)
- **WP/ACC input pin**
At V_{IL}, allows protection of boot sectors, regardless of sector protection/unprotection status
(MB84VD2208XEA:SA69,SA70 MB84VD2209XEA:SA0,SA1)
At V_{IH}, allows removal of boot sector protection
At V_{ACC}, program time will reduce by 40%.
- **Erase Suspend/Resume**
Suspends the erase operation to allow a read in another sector within the same device
- **Please refer to “MBM29DL32XTE/BE” data sheet in detailed function**

2. SRAM

- **Power dissipation**
Operating : 40 mA max.
Standby : 7 μA max.
- **Power down features using $\overline{CE1}$ s and CE2s**
- **Data retention supply voltage: 1.5 V to 3.3 V**
- **$\overline{CE1}$ s and CE2s Chip Select**
- **Byte data control: \overline{LB} s (DQ₀ to DQ₇), \overline{UB} s(DQ₈ to DQ₁₅)**

Embedded Erase™ and Embedded Program™ are trademarks of Advanced Micro Devices, Inc.

MB84VD2208XEA-90/MB84VD2209XEA-90

■ PIN ASSIGNMENT

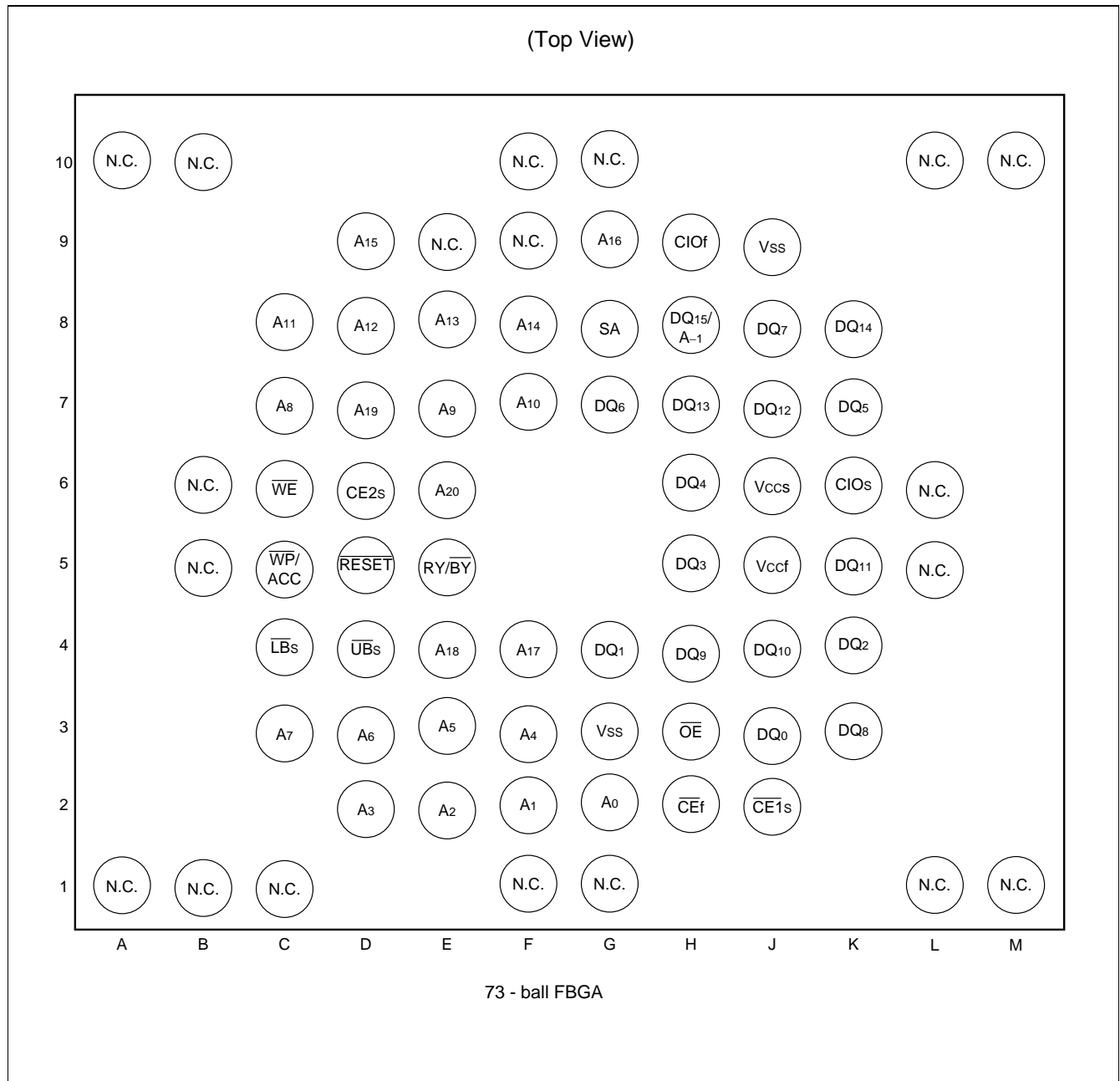

MB84VD2208XEA-90/MB84VD2209XEA-90

■ PIN DESCRIPTION

| Pin No. | Pin name | Function | Input/Output |
|--|---|--|--------------|
| G2 F2 E2 D2 F3 E3 D3 C3 C7 E7 F7 C8 C8 E8 F8 D9 G9 | A ₀ A ₁ A ₂ A ₃ A ₄ A ₅ A ₆ A ₇ A ₈ A ₉ A ₁₀ A ₁₁ A ₁₂ A ₁₃ A ₁₄ A ₁₅ A ₁₆ | Address Inputs (Common) | I |
| H8 F4 E4 D7 E6 | A ₋₁ A ₁₇ A ₁₈ A ₁₉ A ₂₀ | Address Input (Flash) | I |
| G8 | SA | Address Input (SRAM) | I |
| J3 G4 K4 H5 H6 K7 G7 J8 K3 H4 J4 K5 J7 H7 K8 H8 | DQ ₀ DQ ₁ DQ ₂ DQ ₃ DQ ₄ DQ ₅ DQ ₆ DQ ₇ DQ ₈ DQ ₉ DQ ₁₀ DQ ₁₁ DQ ₁₂ DQ ₁₃ DQ ₁₄ DD ₁₅ | Data Inputs/Outputs (Common) | I/O |
| H2 | $\overline{CE}f$ | Chip Enable (Flash) | I |
| J2 | $\overline{CE}1s$ | Chip Enable (SRAM) | I |
| D6 | $\overline{CE}2s$ | Chip Enable (SRAM) | I |
| H3 | \overline{OE} | Output Enable (Common) | I |
| C6 | \overline{WE} | Write Enable (Common) | I |
| E5 | RY/ \overline{BY} | Ready/Busy Outputs (Flash) Open Drain Output | O |

(Continued)

MB84VD2208XEA-90/MB84VD2209XEA-90

(Continued)

| Pin No. | Pin name | Function | Input/Output |
|--|---------------------|--|--------------|
| D4 | \overline{UBs} | Upper Byte Control (SRAM) | I |
| C4 | \overline{LBs} | Lower Byte Control (SRAM) | I |
| H9 | CIO _f | I/O Configuration (Flash) CIO _f = V _{IH} is Word mode (×16), CIO _f = V _{IL} is Byte mode (×8) | I |
| K6 | CIO _s | I/O Configuration (SRAM) CIO _s = V _{IH} is Word mode (×16), CIO _s = V _{IL} is Byte mode (×8) | I |
| D5 | \overline{RESET} | Hardware Reset Pin/Sector Protection Unlock (Flash) | I |
| C5 | $\overline{WP/ACC}$ | Write Protect / Acceleration (Flash) | I |
| A1, A10, B1, B5, B6, B10, C1, E9, F1, F9, F10, G1, G10, L1, L5, L6, L10, M1, M10 | N.C. | No Internal Connection | — |
| J9, G3 | V _{SS} | Device Ground (Common) | Power |
| J5 | V _{CCf} | Device Power Supply (Flash) | Power |
| J6 | V _{CCS} | Device Power Supply (SRAM) | Power |

MB84VD2208XEA-90/MB84VD2209XEA-90

■ DEVICE BUS OPERATIONS

Table 1. 1 User Bus Operations (Flash=Word mode; CIOf=V_{ccf}, SRAM=Word mode; CIOs=V_{ccs})

| Operation (Note1, 3) | $\overline{CE}f$ | $\overline{CE}1s$ | $CE2s$ | \overline{OE} | \overline{WE} | SA (Note6) | $\overline{LB}s$ | $\overline{UB}s$ | DQ ₀ to DQ ₇ | DQ ₈ to DQ ₁₅ | \overline{RESET} | $\overline{WP}/$ ACC (Note5) |
|---|------------------|-------------------|--------|-----------------|-----------------|---------------|------------------|------------------|---------------------------------------|--|--------------------|------------------------------------|
| Full Standby | H | H | X | X | X | X | X | X | HIGH-Z | HIGH-Z | H | X |
| | | X | L | | | | | | | | | |
| Output Disable | H | L | H | H | H | X | X | X | HIGH-Z | HIGH-Z | H | X |
| | | | | X | X | X | H | H | HIGH-Z | HIGH-Z | | |
| | L | H | X | H | H | X | X | X | HIGH-Z | HIGH-Z | | |
| | | X | L | | | | | | | | | |
| Read from Flash (Note2) | L | H | X | L | H | X | X | X | D _{OUT} | D _{OUT} | H | X |
| | | X | L | | | | | | | | | |
| Write to Flash | L | H | X | H | L | X | X | X | D _{IN} | D _{IN} | H | X |
| | | X | L | | | | | | | | | |
| Read from SRAM | H | L | H | L | H | X | L | L | D _{OUT} | D _{OUT} | H | X |
| | | | | | | | H | L | HIGH-Z | D _{OUT} | | |
| | | | | | | | L | H | D _{OUT} | HIGH-Z | | |
| Write to SRAM | H | L | H | X | L | X | L | L | D _{IN} | D _{IN} | H | X |
| | | | | | | | H | L | HIGH-Z | D _{IN} | | |
| | | | | | | | L | H | D _{IN} | HIGH-Z | | |
| Temporary Sector Group Unprotection (Note4) | X | X | X | X | X | X | X | X | X | X | V _{ID} | X |
| Flash Hardware Reset | X | H | X | X | X | X | X | X | HIGH-Z | HIGH-Z | L | X |
| | | X | L | | | | | | | | | |
| Boot Block Sector Write Protection | X | X | X | X | X | X | X | X | X | X | X | L |

Legend: L = V_{IL}, H = V_{IH}, X = V_{IL} or V_{IH}. See "■ELECTRICAL CHARACTERISTICS 1.DC Characteristics" for voltage levels.

- Notes:
1. Other operations except for indicated this column are inhibited.
 2. \overline{WE} can be V_{IL} if \overline{OE} is V_{IL}, \overline{OE} at V_{IH} initiates the write operations.
 3. Do not apply $\overline{CE}f = V_{IL}$, $\overline{CE}1s = V_{IL}$ and $CE2s = V_{IH}$ at a time.
 4. It is also used for the extended sector group protections.
 5. $\overline{WP}/ACC = V_{IL}$; protection of boot sectors.
 $\overline{WP}/ACC = V_{IH}$; removal of boot sectors protection.
 $\overline{WP}/ACC = V_{ACC}$ (9V) ; Program time will reduce by 40%.
 6. SA; Don't care or Open.

MB84VD2208XEA-90/MB84VD2209XEA-90

Table 1. 2 User Bus Operations (Flash=Word mode; CIOf=V_{ccf}, SRAM=Byte mode; CIOs=V_{ss})

| Operation (Note1, 3) | \overline{CEf} | $\overline{CE1s}$ | CE2s | \overline{OE} | \overline{WE} | SA | \overline{LBs} (Note6) | \overline{UBs} (Note6) | DQ ₀ to DQ ₇ | DQ ₈ to DQ ₁₅ | \overline{RESET} | $\overline{WP/ACC}$ (Note5) |
|--|------------------|-------------------|------|-----------------|-----------------|----|-----------------------------|-----------------------------|---------------------------------------|--|--------------------|--------------------------------|
| Full Standby | H | H | X | X | X | X | X | X | HIGH-Z | HIGH-Z | H | X |
| | | X | L | | | | | | | | | |
| Output Disable | H | L | H | H | H | X | X | X | HIGH-Z | HIGH-Z | H | X |
| | | | | X | X | X | X | X | HIGH-Z | HIGH-Z | | |
| | L | H | X | H | H | X | X | X | HIGH-Z | HIGH-Z | | |
| | | | | | | | | | | | | |
| Read from Flash (Note2) | L | H | X | L | H | X | X | X | D _{OUT} | D _{OUT} | H | X |
| | | X | L | | | | | | | | | |
| Write to Flash | L | H | X | H | L | X | X | X | D _{IN} | D _{IN} | H | X |
| | | X | L | | | | | | | | | |
| Read from SRAM | H | L | H | L | H | SA | X | X | D _{OUT} | HIGH-Z | H | X |
| Write to SRAM | H | L | H | X | L | SA | X | X | D _{IN} | HIGH-Z | H | X |
| Temporary Sector Group Unprotection (Note4) | X | X | X | X | X | X | X | X | X | X | V _{ID} | X |
| Flash Hardware Reset | X | H | X | X | X | X | X | X | HIGH-Z | HIGH-Z | L | X |
| | | X | L | | | | | | | | | |
| Boot Block Sector Write Protection | X | X | X | X | X | X | X | X | X | X | X | L |

Legend: L = V_{IL}, H = V_{IH}, X = V_{IL} or V_{IH}. See "ELECTRICAL CHARACTERISTICS 1.DC Characteristics" for voltage levels.

- Notes:
1. Other operations except for indicated this column are inhibited.
 2. \overline{WE} can be V_{IL} if \overline{OE} is V_{IL}, \overline{OE} at V_{IH} initiates the write operations.
 3. Do not apply $\overline{CEf} = V_{IL}$, $\overline{CE1s} = V_{IL}$ and CE2s = V_{IH} at a time.
 4. It is also used for the extended sector group protections.
 5. $\overline{WP/ACC} = V_{IL}$; protection of boot sectors.
 $\overline{WP/ACC} = V_{IH}$; removal of boot sectors protection.
 $\overline{WP/ACC} = V_{ACC}$ (9V) ; Program time will reduce by 40%.
 6. SA; Don't care or Open.

MB84VD2208XEA-90/MB84VD2209XEA-90

Table 1.3 User Bus Operations (Flash=Byte mode; CIOf=V_{ss}, SRAM=Byte mode; CIOs=V_{ss})

| Operation (Note1, 3) | \overline{CEf} | $\overline{CE1s}$ | $CE2s$ | DQ_{15}/A_{-1} | \overline{OE} | \overline{WE} | SA | \overline{LBs} (Note6) | \overline{UBs} (Note6) | DQ ₀ to DQ ₇ | DQ ₈ to DQ ₁₄ | \overline{RESET} | $\overline{WP/ACC}$ (Note5) |
|--|------------------|-------------------|--------|------------------|-----------------|-----------------|----|-----------------------------|-----------------------------|---------------------------------------|--|--------------------|--------------------------------|
| Full Standby | H | H | X | X | X | X | X | X | X | HIGH-Z | HIGH-Z | H | X |
| | | X | L | | | | | | | | | | |
| Output Disable | H | L | H | X | H | H | X | X | X | HIGH-Z | HIGH-Z | H | X |
| | | | | X | X | X | X | X | X | HIGH-Z | HIGH-Z | | |
| | L | H | X | A ₋₁ | H | H | X | X | X | HIGH-Z | HIGH-Z | | |
| | | X | L | | | | | | | | | | |
| Read from Flash (Note2) | L | H | X | A ₋₁ | L | H | X | X | X | D _{OUT} | X | H | X |
| | | X | L | | | | | | | | | | |
| Write to Flash | L | H | X | A ₋₁ | H | L | X | X | X | D _{IN} | X | H | X |
| | | X | L | | | | | | | | | | |
| Read from SRAM | H | L | H | X | L | H | SA | X | X | D _{OUT} | HIGH-Z | H | X |
| Write to SRAM | H | L | H | X | X | L | SA | X | X | D _{IN} | HIGH-Z | H | X |
| Temporary Sector Group Unprotection (Note4) | X | X | X | X | X | X | X | X | X | X | X | V _{ID} | X |
| Flash Hardware Reset | X | H | X | X | X | X | X | X | X | HIGH-Z | HIGH-Z | L | X |
| | | X | L | | | | | | | | | | |
| Boot Block Sector Write Protection | X | X | X | X | X | X | X | X | X | X | X | X | L |

Legend: L = V_{IL}, H = V_{IH}, X = V_{IL} or V_{IH}. See "■ELECTRICAL CHARACTERISTICS 1.DC Characteristics" for voltage levels.

- Notes:
1. Other operations except for indicated this column are inhibited.
 2. \overline{WE} can be V_{IL} if \overline{OE} is V_{IL}, \overline{OE} at V_{IH} initiates the write operations.
 3. Do not apply $\overline{CEf} = V_{IL}$, $\overline{CE1s} = V_{IL}$ and $CE2s = V_{IH}$ at a time.
 4. It is also used for the extended sector group protections.
 5. $\overline{WP/ACC} = V_{IL}$; protection of boot sectors.
 $\overline{WP/ACC} = V_{IH}$; removal of boot sectors protection.
 $\overline{WP/ACC} = V_{ACC}$ (9V) ; Program time will reduce by 40%.
 6. SA; Don't care or Open.

MB84VD2208XEA-90/MB84VD2209XEA-90

■ FLEXIBLE SECTOR-ERASE ARCHITECTURE on FLASH MEMORY

- Eight 4 K words, and sixty three 32 K words.
- Individual-sector, multiple-sector, or bulk-erase capability.

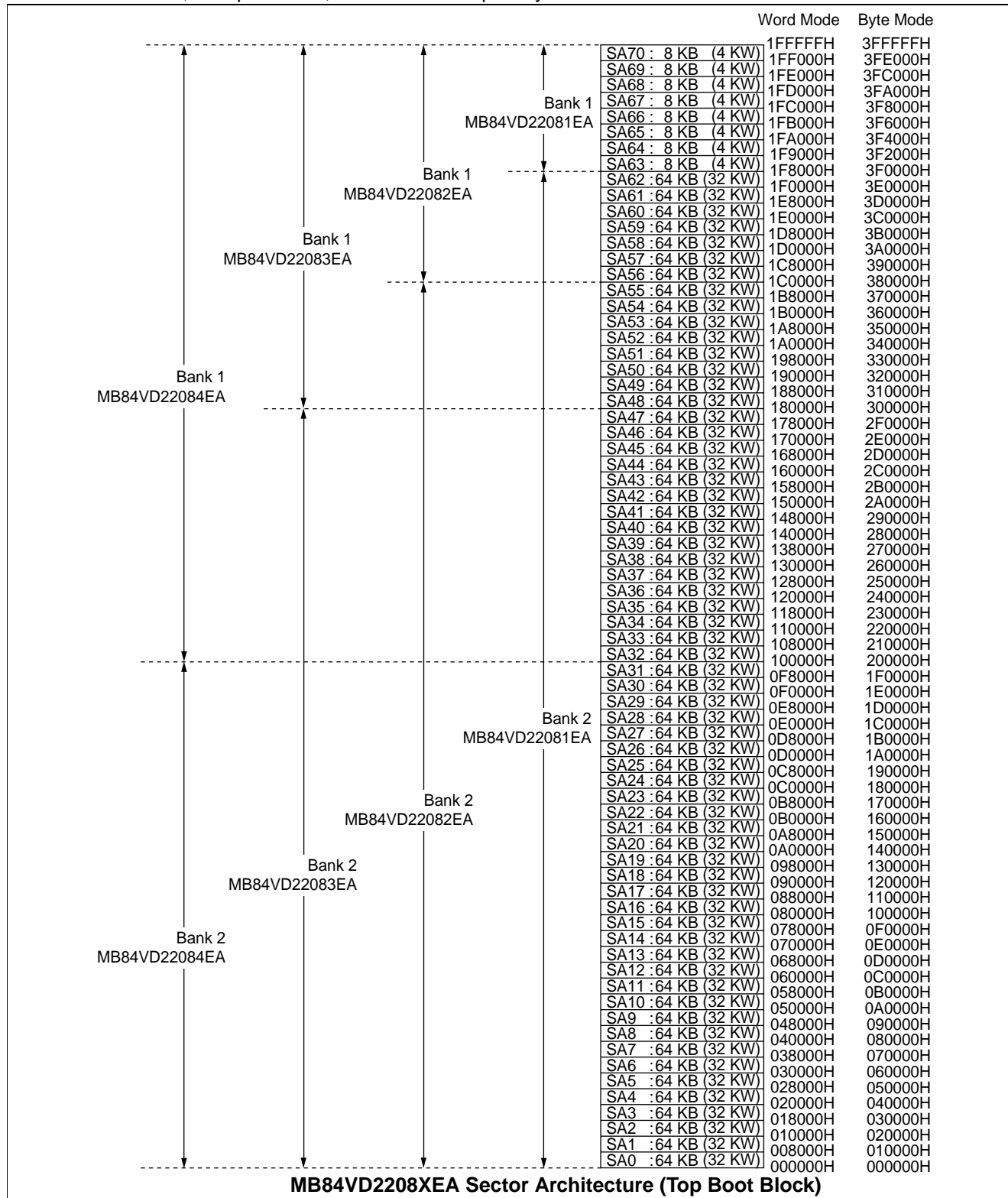

(Continued)

MB84VD2208XEA-90/MB84VD2209XEA-90

(Continued)

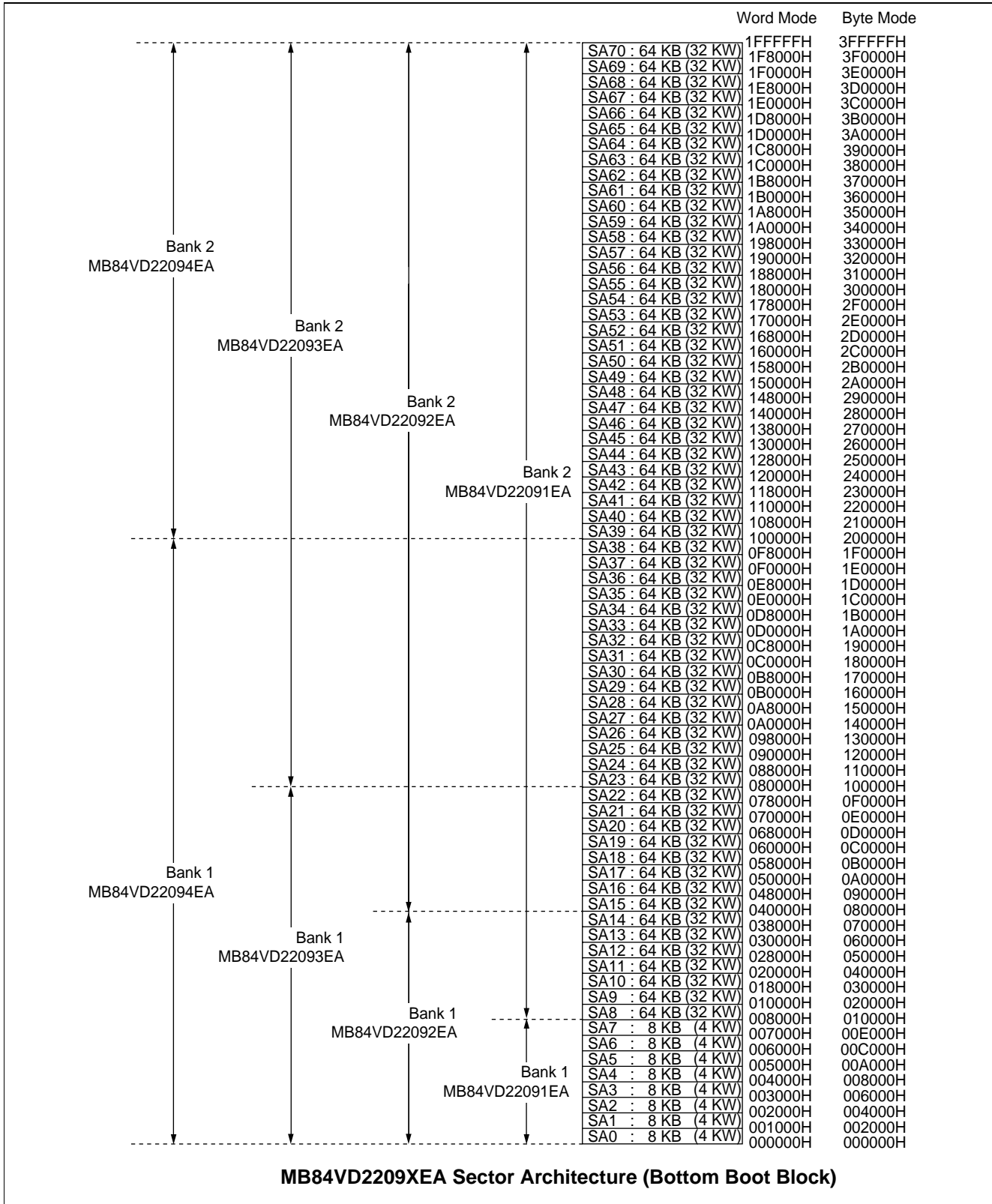

MB84VD2208XEA-90/MB84VD2209XEA-90

Table 2. 1 Sector Address Tables (MB84VD22081EA)

| Bank | Sector | Sector Address | | | | | | | | | | Address Range (BYTE mode) | Address Range (WORD mode) |
|--------|--------|----------------|-----|-----|-----|-----|-----|-----|-----|-----|--------------------|------------------------------|------------------------------|
| | | Bank Address | | | | | | | | | | | |
| | | A20 | A19 | A18 | A17 | A16 | A15 | A14 | A13 | A12 | A11 | | |
| Bank 2 | SA0 | 0 | 0 | 0 | 0 | 0 | 0 | X | X | X | X | 000000H to 00FFFFH | 000000H to 007FFFH |
| | SA1 | 0 | 0 | 0 | 0 | 0 | 1 | X | X | X | X | 010000H to 01FFFFH | 008000H to 00FFFFH |
| | SA2 | 0 | 0 | 0 | 0 | 1 | 0 | X | X | X | X | 020000H to 02FFFFH | 010000H to 017FFFH |
| | SA3 | 0 | 0 | 0 | 0 | 1 | 1 | X | X | X | X | 030000H to 03FFFFH | 018000H to 01FFFFH |
| | SA4 | 0 | 0 | 0 | 1 | 0 | 0 | X | X | X | X | 040000H to 04FFFFH | 020000H to 027FFFH |
| | SA5 | 0 | 0 | 0 | 1 | 0 | 1 | X | X | X | X | 050000H to 05FFFFH | 028000H to 02FFFFH |
| | SA6 | 0 | 0 | 0 | 1 | 1 | 0 | X | X | X | X | 060000H to 06FFFFH | 030000H to 037FFFH |
| | SA7 | 0 | 0 | 0 | 1 | 1 | 1 | X | X | X | X | 070000H to 07FFFFH | 038000H to 03FFFFH |
| | SA8 | 0 | 0 | 1 | 0 | 0 | 0 | X | X | X | X | 080000H to 08FFFFH | 040000H to 047FFFH |
| | SA9 | 0 | 0 | 1 | 0 | 0 | 1 | X | X | X | X | 090000H to 09FFFFH | 048000H to 04FFFFH |
| | SA10 | 0 | 0 | 1 | 0 | 1 | 0 | X | X | X | X | 0A0000H to 0AFFFFH | 050000H to 057FFFH |
| | SA11 | 0 | 0 | 1 | 0 | 1 | 1 | X | X | X | X | 0B0000H to 0BFFFFH | 058000H to 05FFFFH |
| | SA12 | 0 | 0 | 1 | 1 | 0 | 0 | X | X | X | X | 0C0000H to 0CFFFFH | 060000H to 067FFFH |
| | SA13 | 0 | 0 | 1 | 1 | 0 | 1 | X | X | X | X | 0D0000H to 0DFFFFH | 068000H to 06FFFFH |
| | SA14 | 0 | 0 | 1 | 1 | 1 | 0 | X | X | X | X | 0E0000H to 0EFFFFH | 070000H to 077FFFH |
| | SA15 | 0 | 0 | 1 | 1 | 1 | 1 | X | X | X | X | 0F0000H to 0FFFFFH | 078000H to 07FFFFH |
| | SA16 | 0 | 1 | 0 | 0 | 0 | 0 | X | X | X | X | 100000H to 10FFFFH | 080000H to 087FFFH |
| | SA17 | 0 | 1 | 0 | 0 | 0 | 1 | X | X | X | X | 110000H to 11FFFFH | 088000H to 08FFFFH |
| | SA18 | 0 | 1 | 0 | 0 | 1 | 0 | X | X | X | X | 120000H to 12FFFFH | 090000H to 097FFFH |
| | SA19 | 0 | 1 | 0 | 0 | 1 | 1 | X | X | X | X | 130000H to 13FFFFH | 098000H to 09FFFFH |
| | SA20 | 0 | 1 | 0 | 1 | 0 | 0 | X | X | X | X | 140000H to 14FFFFH | 0A0000H to 0A7FFFH |
| | SA21 | 0 | 1 | 0 | 1 | 0 | 1 | X | X | X | X | 150000H to 15FFFFH | 0A8000H to 0AFFFFH |
| | SA22 | 0 | 1 | 0 | 1 | 1 | 0 | X | X | X | X | 160000H to 16FFFFH | 0B0000H to 0B7FFFH |
| | SA23 | 0 | 1 | 0 | 1 | 1 | 1 | X | X | X | X | 170000H to 17FFFFH | 0B8000H to 0BFFFFH |
| | SA24 | 0 | 1 | 1 | 0 | 0 | 0 | X | X | X | X | 180000H to 18FFFFH | 0C0000H to 0C7FFFH |
| | SA25 | 0 | 1 | 1 | 0 | 0 | 1 | X | X | X | X | 190000H to 19FFFFH | 0C8000H to 0CFFFFH |
| | SA26 | 0 | 1 | 1 | 0 | 1 | 0 | X | X | X | X | 1A0000H to 1AFFFFH | 0D0000H to 0D7FFFH |
| | SA27 | 0 | 1 | 1 | 0 | 1 | 1 | X | X | X | X | 1B0000H to 1BFFFFH | 0D8000H to 0DFFFFH |
| | SA28 | 0 | 1 | 1 | 1 | 0 | 0 | X | X | X | X | 1C0000H to 1CFFFFH | 0E0000H to 0E7FFFH |
| | SA29 | 0 | 1 | 1 | 1 | 0 | 1 | X | X | X | X | 1D0000H to 1DFFFFH | 0E8000H to 0EFFFFH |
| | SA30 | 0 | 1 | 1 | 1 | 1 | 0 | X | X | X | X | 1E0000H to 1EFFFFH | 0F0000H to 0F7FFFH |
| SA31 | 0 | 1 | 1 | 1 | 1 | 1 | X | X | X | X | 1F0000H to 1FFFFFH | 0F8000H to 0FFFFFH | |

(Continued)

MB84VD2208XEA-90/MB84VD2209XEA-90

(Continued)

| Bank | Sector | Sector Address | | | | | | | | | | Address Range (BYTE mode) | Address Range (WORD mode) |
|--------|--------|----------------|-----|-----|-----|-----|-----|-----|-----|-----|--------------------|------------------------------|------------------------------|
| | | Bank Address | | | | | | | | | | | |
| | | A20 | A19 | A18 | A17 | A16 | A15 | A14 | A13 | A12 | A11 | | |
| Bank 2 | SA32 | 1 | 0 | 0 | 0 | 0 | 0 | X | X | X | X | 200000H to 20FFFFH | 100000H to 107FFFFH |
| | SA33 | 1 | 0 | 0 | 0 | 0 | 1 | X | X | X | X | 210000H to 21FFFFH | 108000H to 10FFFFH |
| | SA34 | 1 | 0 | 0 | 0 | 1 | 0 | X | X | X | X | 220000H to 22FFFFH | 110000H to 117FFFFH |
| | SA35 | 1 | 0 | 0 | 0 | 1 | 1 | X | X | X | X | 230000H to 23FFFFH | 118000H to 11FFFFH |
| | SA36 | 1 | 0 | 0 | 1 | 0 | 0 | X | X | X | X | 240000H to 24FFFFH | 120000H to 127FFFFH |
| | SA37 | 1 | 0 | 0 | 1 | 0 | 1 | X | X | X | X | 250000H to 25FFFFH | 128000H to 12FFFFH |
| | SA38 | 1 | 0 | 0 | 1 | 1 | 0 | X | X | X | X | 260000H to 26FFFFH | 130000H to 137FFFFH |
| | SA39 | 1 | 0 | 0 | 1 | 1 | 1 | X | X | X | X | 270000H to 27FFFFH | 138000H to 13FFFFH |
| | SA40 | 1 | 0 | 1 | 0 | 0 | 0 | X | X | X | X | 280000H to 28FFFFH | 140000H to 147FFFFH |
| | SA41 | 1 | 0 | 1 | 0 | 0 | 1 | X | X | X | X | 290000H to 29FFFFH | 148000H to 14FFFFH |
| | SA42 | 1 | 0 | 1 | 0 | 1 | 0 | X | X | X | X | 2A0000H to 2AFFFFH | 150000H to 157FFFFH |
| | SA43 | 1 | 0 | 1 | 0 | 1 | 1 | X | X | X | X | 2B0000H to 2BFFFFH | 158000H to 15FFFFH |
| | SA44 | 1 | 0 | 1 | 1 | 0 | 0 | X | X | X | X | 2C0000H to 2CFFFFH | 160000H to 167FFFFH |
| | SA45 | 1 | 0 | 1 | 1 | 0 | 1 | X | X | X | X | 2D0000H to 2DFFFFH | 168000H to 16FFFFH |
| | SA46 | 1 | 0 | 1 | 1 | 1 | 0 | X | X | X | X | 2E0000H to 2EFFFFH | 170000H to 177FFFFH |
| | SA47 | 1 | 0 | 1 | 1 | 1 | 1 | X | X | X | X | 2F0000H to 2FFFFFH | 178000H to 17FFFFH |
| | SA48 | 1 | 1 | 0 | 0 | 0 | 0 | X | X | X | X | 300000H to 30FFFFH | 180000H to 187FFFFH |
| | SA49 | 1 | 1 | 0 | 0 | 0 | 1 | X | X | X | X | 310000H to 31FFFFH | 188000H to 18FFFFH |
| | SA50 | 1 | 1 | 0 | 0 | 1 | 0 | X | X | X | X | 320000H to 32FFFFH | 190000H to 197FFFFH |
| | SA51 | 1 | 1 | 0 | 0 | 1 | 1 | X | X | X | X | 330000H to 33FFFFH | 198000H to 19FFFFH |
| | SA52 | 1 | 1 | 0 | 1 | 0 | 0 | X | X | X | X | 340000H to 34FFFFH | 1A0000H to 1A7FFFFH |
| | SA53 | 1 | 1 | 0 | 1 | 0 | 1 | X | X | X | X | 350000H to 35FFFFH | 1A8000H to 1AFFFFH |
| | SA54 | 1 | 1 | 0 | 1 | 1 | 0 | X | X | X | X | 360000H to 36FFFFH | 1B0000H to 1B7FFFFH |
| | SA55 | 1 | 1 | 0 | 1 | 1 | 1 | X | X | X | X | 370000H to 37FFFFH | 1B8000H to 1BFFFFH |
| SA56 | 1 | 1 | 1 | 0 | 0 | 0 | X | X | X | X | 380000H to 38FFFFH | 1C0000H to 1C7FFFFH | |
| SA57 | 1 | 1 | 1 | 0 | 0 | 1 | X | X | X | X | 390000H to 39FFFFH | 1C8000H to 1CFFFFH | |
| SA58 | 1 | 1 | 1 | 0 | 1 | 0 | X | X | X | X | 3A0000H to 3AFFFFH | 1D0000H to 1D7FFFFH | |
| SA59 | 1 | 1 | 1 | 0 | 1 | 1 | X | X | X | X | 3B0000H to 3BFFFFH | 1D8000H to 1DFFFFH | |
| SA60 | 1 | 1 | 1 | 1 | 0 | 0 | X | X | X | X | 3C0000H to 3CFFFFH | 1E0000H to 1E7FFFFH | |
| SA61 | 1 | 1 | 1 | 1 | 0 | 1 | X | X | X | X | 3D0000H to 3DFFFFH | 1E8000H to 1EFFFFH | |
| SA62 | 1 | 1 | 1 | 1 | 1 | 0 | X | X | X | X | 3E0000H to 3EFFFFH | 1F0000H to 1F7FFFFH | |
| Bank 1 | SA63 | 1 | 1 | 1 | 1 | 1 | 1 | 0 | 0 | 0 | X | 3F0000H to 3F1FFFFH | 1F8000H to 1F8FFFFH |
| | SA64 | 1 | 1 | 1 | 1 | 1 | 1 | 0 | 0 | 1 | X | 3F2000H to 3F3FFFFH | 1F9000H to 1F9FFFFH |
| | SA65 | 1 | 1 | 1 | 1 | 1 | 1 | 0 | 1 | 0 | X | 3F4000H to 3F5FFFFH | 1FA000H to 1FAFFFFH |
| | SA66 | 1 | 1 | 1 | 1 | 1 | 1 | 0 | 1 | 1 | X | 3F6000H to 3F7FFFFH | 1FB000H to 1FBFFFFH |
| | SA67 | 1 | 1 | 1 | 1 | 1 | 1 | 1 | 0 | 0 | X | 3F8000H to 3F9FFFFH | 1FC000H to 1FCFFFFH |
| | SA68 | 1 | 1 | 1 | 1 | 1 | 1 | 1 | 0 | 1 | X | 3FA000H to 3FAFFFFH | 1FD000H to 1FDFFFFH |
| | SA69 | 1 | 1 | 1 | 1 | 1 | 1 | 1 | 1 | 0 | X | 3FC000H to 3FCFFFFH | 1FE000H to 1FEFFFFH |
| | SA70 | 1 | 1 | 1 | 1 | 1 | 1 | 1 | 1 | 1 | X | 3FE000H to 3FFFFFFH | 1FF000H to 1FFFFFFH |

MB84VD2208XEA-90/MB84VD2209XEA-90

Table 2. 2 Sector Address Tables (MB84VD22091EA)

| Bank | Sector | Sector Address | | | | | | | | | | Address Range (BYTE mode) | Address Range (WORD mode) |
|--------|--------|----------------|-----|-----|-----|-----|-----|-----|-----|-----|----------------------|------------------------------|------------------------------|
| | | Band Address | | | | | | | | | | | |
| | | A20 | A19 | A18 | A17 | A16 | A15 | A14 | A13 | A12 | A11 | | |
| Bank 1 | SA0 | 0 | 0 | 0 | 0 | 0 | 0 | 0 | 0 | 0 | X | 000000H to 001FFFFH | 000000H to 000FFFFH |
| | SA1 | 0 | 0 | 0 | 0 | 0 | 0 | 0 | 0 | 0 | 1 | 002000H to 003FFFFH | 001000H to 001FFFFH |
| | SA2 | 0 | 0 | 0 | 0 | 0 | 0 | 0 | 0 | 1 | 0 | 004000H to 005FFFFH | 002000H to 002FFFFH |
| | SA3 | 0 | 0 | 0 | 0 | 0 | 0 | 0 | 0 | 1 | 1 | 006000H to 007FFFFH | 003000H to 003FFFFH |
| | SA4 | 0 | 0 | 0 | 0 | 0 | 0 | 0 | 1 | 0 | 0 | 008000H to 009FFFFH | 004000H to 004FFFFH |
| | SA5 | 0 | 0 | 0 | 0 | 0 | 0 | 0 | 1 | 0 | 1 | 00A000H to 00BFFFFH | 005000H to 005FFFFH |
| | SA6 | 0 | 0 | 0 | 0 | 0 | 0 | 0 | 1 | 1 | 0 | 00C000H to 00DFFFFH | 006000H to 006FFFFH |
| SA7 | 0 | 0 | 0 | 0 | 0 | 0 | 0 | 1 | 1 | 1 | 00E000H to 00FFFFFFH | 007000H to 007FFFFH | |
| Bank 2 | SA8 | 0 | 0 | 0 | 0 | 0 | 1 | X | X | X | X | 010000H to 01FFFFFFH | 008000H to 00FFFFFFH |
| | SA9 | 0 | 0 | 0 | 0 | 1 | 0 | X | X | X | X | 020000H to 02FFFFFFH | 010000H to 017FFFFH |
| | SA10 | 0 | 0 | 0 | 0 | 1 | 1 | X | X | X | X | 030000H to 03FFFFFFH | 018000H to 01FFFFFFH |
| | SA11 | 0 | 0 | 0 | 1 | 0 | 0 | X | X | X | X | 040000H to 04FFFFFFH | 020000H to 027FFFFH |
| | SA12 | 0 | 0 | 0 | 1 | 0 | 1 | X | X | X | X | 050000H to 05FFFFFFH | 028000H to 02FFFFFFH |
| | SA13 | 0 | 0 | 0 | 1 | 1 | 0 | X | X | X | X | 060000H to 06FFFFFFH | 030000H to 037FFFFH |
| | SA14 | 0 | 0 | 0 | 1 | 1 | 1 | X | X | X | X | 070000H to 07FFFFFFH | 038000H to 03FFFFFFH |
| | SA15 | 0 | 0 | 1 | 0 | 0 | 0 | X | X | X | X | 080000H to 08FFFFFFH | 040000H to 047FFFFH |
| | SA16 | 0 | 0 | 1 | 0 | 0 | 1 | X | X | X | X | 090000H to 09FFFFFFH | 048000H to 04FFFFFFH |
| | SA17 | 0 | 0 | 1 | 0 | 1 | 0 | X | X | X | X | 0A0000H to 0AFFFFFFH | 050000H to 057FFFFH |
| | SA18 | 0 | 0 | 1 | 0 | 1 | 1 | X | X | X | X | 0B0000H to 0BFFFFFFH | 058000H to 05FFFFFFH |
| | SA19 | 0 | 0 | 1 | 1 | 0 | 0 | X | X | X | X | 0C0000H to 0CFFFFFFH | 060000H to 067FFFFH |
| | SA20 | 0 | 0 | 1 | 1 | 0 | 1 | X | X | X | X | 0D0000H to 0DFFFFFFH | 068000H to 06FFFFFFH |
| | SA21 | 0 | 0 | 1 | 1 | 1 | 0 | X | X | X | X | 0E0000H to 0EFFFFFFH | 070000H to 077FFFFH |
| | SA22 | 0 | 0 | 1 | 1 | 1 | 1 | X | X | X | X | 0F0000H to 0FFFFFFH | 078000H to 07FFFFFFH |
| | SA23 | 0 | 1 | 0 | 0 | 0 | 0 | X | X | X | X | 100000H to 10FFFFFFH | 080000H to 087FFFFH |
| | SA24 | 0 | 1 | 0 | 0 | 0 | 1 | X | X | X | X | 110000H to 11FFFFFFH | 088000H to 08FFFFFFH |
| | SA25 | 0 | 1 | 0 | 0 | 1 | 0 | X | X | X | X | 120000H to 12FFFFFFH | 090000H to 097FFFFH |
| | SA26 | 0 | 1 | 0 | 0 | 1 | 1 | X | X | X | X | 130000H to 13FFFFFFH | 098000H to 09FFFFFFH |
| | SA27 | 0 | 1 | 0 | 1 | 0 | 0 | X | X | X | X | 140000H to 14FFFFFFH | 0A0000H to 0A7FFFFH |
| | SA28 | 0 | 1 | 0 | 1 | 0 | 1 | X | X | X | X | 150000H to 15FFFFFFH | 0A8000H to 0AFFFFFFH |
| | SA29 | 0 | 1 | 0 | 1 | 1 | 0 | X | X | X | X | 160000H to 16FFFFFFH | 0B0000H to 0B7FFFFH |
| | SA30 | 0 | 1 | 0 | 1 | 1 | 1 | X | X | X | X | 170000H to 17FFFFFFH | 0B8000H to 0BFFFFFFH |
| | SA31 | 0 | 1 | 1 | 0 | 0 | 0 | X | X | X | X | 180000H to 18FFFFFFH | 0C0000H to 0C7FFFFH |
| | SA32 | 0 | 1 | 1 | 0 | 0 | 1 | X | X | X | X | 190000H to 19FFFFFFH | 0C8000H to 0CFFFFFFH |
| | SA33 | 0 | 1 | 1 | 0 | 1 | 0 | X | X | X | X | 1A0000H to 1AFFFFFFH | 0D0000H to 0D7FFFFH |
| | SA34 | 0 | 1 | 1 | 0 | 1 | 1 | X | X | X | X | 1B0000H to 1BFFFFFFH | 0D8000H to 0DFFFFFFH |
| | SA35 | 0 | 1 | 1 | 1 | 0 | 0 | X | X | X | X | 1C0000H to 1CFFFFFFH | 0E0000H to 0E7FFFFH |
| | SA36 | 0 | 1 | 1 | 1 | 0 | 1 | X | X | X | X | 1D0000H to 1DFFFFFFH | 0E8000H to 0EFFFFFFH |

(Continued)

MB84VD2208XEA-90/MB84VD2209XEA-90

(Continued)

| Bank | Sector | Sector Address | | | | | | | | | | Address Range (BYTE mode) | Address Range (WORD mode) |
|--------|--------|----------------|-----|-----|-----|-----|-----|-----|-----|-----|---------------------|------------------------------|------------------------------|
| | | Bank Address | | | | | | | | | | | |
| | | A20 | A19 | A18 | A17 | A16 | A15 | A14 | A13 | A12 | A11 | | |
| Bank 2 | SA37 | 0 | 1 | 1 | 1 | 1 | 0 | X | X | X | X | 1E0000H to 1EFFFFH | 0F0000H to 0F7FFFH |
| | SA38 | 0 | 1 | 1 | 1 | 1 | 1 | X | X | X | X | 1F0000H to 1FFFFFFH | 0F8000H to 0FFFFFFH |
| | SA39 | 1 | 0 | 0 | 0 | 0 | 0 | X | X | X | X | 200000H to 20FFFFH | 100000H to 107FFFH |
| | SA40 | 1 | 0 | 0 | 0 | 0 | 1 | X | X | X | X | 210000H to 21FFFFH | 108000H to 10FFFFH |
| | SA41 | 1 | 0 | 0 | 0 | 1 | 0 | X | X | X | X | 220000H to 22FFFFH | 110000H to 117FFFH |
| | SA42 | 1 | 0 | 0 | 0 | 1 | 1 | X | X | X | X | 230000H to 23FFFFH | 118000H to 11FFFFH |
| | SA43 | 1 | 0 | 0 | 1 | 0 | 0 | X | X | X | X | 240000H to 24FFFFH | 120000H to 127FFFH |
| | SA44 | 1 | 0 | 0 | 1 | 0 | 1 | X | X | X | X | 250000H to 25FFFFH | 128000H to 12FFFFH |
| | SA45 | 1 | 0 | 0 | 1 | 1 | 0 | X | X | X | X | 260000H to 26FFFFH | 130000H to 137FFFH |
| | SA46 | 1 | 0 | 0 | 1 | 1 | 1 | X | X | X | X | 270000H to 27FFFFH | 138000H to 13FFFFH |
| | SA47 | 1 | 0 | 1 | 0 | 0 | 0 | X | X | X | X | 280000H to 28FFFFH | 140000H to 147FFFH |
| | SA48 | 1 | 0 | 1 | 0 | 0 | 1 | X | X | X | X | 290000H to 29FFFFH | 148000H to 14FFFFH |
| | SA49 | 1 | 0 | 1 | 0 | 1 | 0 | X | X | X | X | 2A0000H to 2AFFFFH | 150000H to 157FFFH |
| | SA50 | 1 | 0 | 1 | 0 | 1 | 1 | X | X | X | X | 2B0000H to 2BFFFFH | 158000H to 15FFFFH |
| | SA51 | 1 | 0 | 1 | 1 | 0 | 0 | X | X | X | X | 2C0000H to 2CFFFFH | 160000H to 167FFFH |
| | SA52 | 1 | 0 | 1 | 1 | 0 | 1 | X | X | X | X | 2D0000H to 2DFFFFH | 168000H to 16FFFFH |
| | SA53 | 1 | 0 | 1 | 1 | 1 | 0 | X | X | X | X | 2E0000H to 2EFFFFH | 170000H to 177FFFH |
| | SA54 | 1 | 0 | 1 | 1 | 1 | 1 | X | X | X | X | 2F0000H to 2FFFFFFH | 178000H to 17FFFFH |
| | SA55 | 1 | 1 | 0 | 0 | 0 | 0 | X | X | X | X | 300000H to 30FFFFH | 180000H to 187FFFH |
| | SA56 | 1 | 1 | 0 | 0 | 0 | 1 | X | X | X | X | 310000H to 31FFFFH | 188000H to 18FFFFH |
| | SA57 | 1 | 1 | 0 | 0 | 1 | 0 | X | X | X | X | 320000H to 32FFFFH | 190000H to 197FFFH |
| | SA58 | 1 | 1 | 0 | 0 | 1 | 1 | X | X | X | X | 330000H to 33FFFFH | 198000H to 19FFFFH |
| | SA59 | 1 | 1 | 0 | 1 | 0 | 0 | X | X | X | X | 340000H to 34FFFFH | 1A0000H to 1A7FFFH |
| | SA60 | 1 | 1 | 0 | 1 | 0 | 1 | X | X | X | X | 350000H to 35FFFFH | 1A8000H to 1AFFFFH |
| | SA61 | 1 | 1 | 0 | 1 | 1 | 0 | X | X | X | X | 360000H to 36FFFFH | 1B0000H to 1B7FFFH |
| | SA62 | 1 | 1 | 0 | 1 | 1 | 1 | X | X | X | X | 370000H to 37FFFFH | 1B8000H to 1BFFFFH |
| | SA63 | 1 | 1 | 1 | 0 | 0 | 0 | X | X | X | X | 380000H to 38FFFFH | 1C0000H to 1C7FFFH |
| | SA64 | 1 | 1 | 1 | 0 | 0 | 1 | X | X | X | X | 390000H to 39FFFFH | 1C8000H to 1CFFFFH |
| | SA65 | 1 | 1 | 1 | 0 | 1 | 0 | X | X | X | X | 3A0000H to 3AFFFFH | 1D0000H to 1D7FFFH |
| | SA66 | 1 | 1 | 1 | 0 | 1 | 1 | X | X | X | X | 3B0000H to 3BFFFFH | 1D8000H to 1DFFFFH |
| SA67 | 1 | 1 | 1 | 1 | 0 | 0 | X | X | X | X | 3C0000H to 3CFFFFH | 1E0000H to 1E7FFFH | |
| SA68 | 1 | 1 | 1 | 1 | 0 | 1 | X | X | X | X | 3D0000H to 3DFFFFH | 1E8000H to 1EFFFFH | |
| SA69 | 1 | 1 | 1 | 1 | 1 | 0 | X | X | X | X | 3E0000H to 3EFFFFH | 1F0000H to 1F7FFFH | |
| SA70 | 1 | 1 | 1 | 1 | 1 | 1 | X | X | X | X | 3F0000H to 3FFFFFFH | 1F8000H to 1FFFFFFH | |

MB84VD2208XEA-90/MB84VD2209XEA-90

Table 2.3 Sector Address Tables (MB84VD22082EA)

| Bank | Sector | Sector Address | | | | | | | | | | Address Range (BYTE mode) | Address Range (WORD mode) |
|--------|--------|----------------|-----|-----|-----|-----|-----|-----|-----|-----|--------------------|------------------------------|------------------------------|
| | | Bank Address | | | | | | | | | | | |
| | | A20 | A19 | A18 | A17 | A16 | A15 | A14 | A13 | A12 | A11 | | |
| Bank 2 | SA0 | 0 | 0 | 0 | 0 | 0 | 0 | X | X | X | X | 000000H to 00FFFFH | 000000H to 007FFFH |
| | SA1 | 0 | 0 | 0 | 0 | 0 | 1 | X | X | X | X | 010000H to 01FFFFH | 008000H to 00FFFFH |
| | SA2 | 0 | 0 | 0 | 0 | 1 | 0 | X | X | X | X | 020000H to 02FFFFH | 010000H to 017FFFH |
| | SA3 | 0 | 0 | 0 | 0 | 1 | 1 | X | X | X | X | 030000H to 03FFFFH | 018000H to 01FFFFH |
| | SA4 | 0 | 0 | 0 | 1 | 0 | 0 | X | X | X | X | 040000H to 04FFFFH | 020000H to 027FFFH |
| | SA5 | 0 | 0 | 0 | 1 | 0 | 1 | X | X | X | X | 050000H to 05FFFFH | 028000H to 02FFFFH |
| | SA6 | 0 | 0 | 0 | 1 | 1 | 0 | X | X | X | X | 060000H to 06FFFFH | 030000H to 037FFFH |
| | SA7 | 0 | 0 | 0 | 1 | 1 | 1 | X | X | X | X | 070000H to 07FFFFH | 038000H to 03FFFFH |
| | SA8 | 0 | 0 | 1 | 0 | 0 | 0 | X | X | X | X | 080000H to 08FFFFH | 040000H to 047FFFH |
| | SA9 | 0 | 0 | 1 | 0 | 0 | 1 | X | X | X | X | 090000H to 09FFFFH | 048000H to 04FFFFH |
| | SA10 | 0 | 0 | 1 | 0 | 1 | 0 | X | X | X | X | 0A0000H to 0AFFFFH | 050000H to 057FFFH |
| | SA11 | 0 | 0 | 1 | 0 | 1 | 1 | X | X | X | X | 0B0000H to 0BFFFFH | 058000H to 05FFFFH |
| | SA12 | 0 | 0 | 1 | 1 | 0 | 0 | X | X | X | X | 0C0000H to 0CFFFFH | 060000H to 067FFFH |
| | SA13 | 0 | 0 | 1 | 1 | 0 | 1 | X | X | X | X | 0D0000H to 0DFFFFH | 068000H to 06FFFFH |
| | SA14 | 0 | 0 | 1 | 1 | 1 | 0 | X | X | X | X | 0E0000H to 0EFFFFH | 070000H to 077FFFH |
| | SA15 | 0 | 0 | 1 | 1 | 1 | 1 | X | X | X | X | 0F0000H to 0FFFFFH | 078000H to 07FFFFH |
| | SA16 | 0 | 1 | 0 | 0 | 0 | 0 | X | X | X | X | 100000H to 10FFFFH | 080000H to 087FFFH |
| | SA17 | 0 | 1 | 0 | 0 | 0 | 1 | X | X | X | X | 110000H to 11FFFFH | 088000H to 08FFFFH |
| | SA18 | 0 | 1 | 0 | 0 | 1 | 0 | X | X | X | X | 120000H to 12FFFFH | 090000H to 097FFFH |
| | SA19 | 0 | 1 | 0 | 0 | 1 | 1 | X | X | X | X | 130000H to 13FFFFH | 098000H to 09FFFFH |
| | SA20 | 0 | 1 | 0 | 1 | 0 | 0 | X | X | X | X | 140000H to 14FFFFH | 0A0000H to 0A7FFFH |
| | SA21 | 0 | 1 | 0 | 1 | 0 | 1 | X | X | X | X | 150000H to 15FFFFH | 0A8000H to 0AFFFFH |
| | SA22 | 0 | 1 | 0 | 1 | 1 | 0 | X | X | X | X | 160000H to 16FFFFH | 0B0000H to 0B7FFFH |
| | SA23 | 0 | 1 | 0 | 1 | 1 | 1 | X | X | X | X | 170000H to 17FFFFH | 0B8000H to 0BFFFFH |
| | SA24 | 0 | 1 | 1 | 0 | 0 | 0 | X | X | X | X | 180000H to 18FFFFH | 0C0000H to 0C7FFFH |
| | SA25 | 0 | 1 | 1 | 0 | 0 | 1 | X | X | X | X | 190000H to 19FFFFH | 0C8000H to 0CFFFFH |
| | SA26 | 0 | 1 | 1 | 0 | 1 | 0 | X | X | X | X | 1A0000H to 1AFFFFH | 0D0000H to 0D7FFFH |
| | SA27 | 0 | 1 | 1 | 0 | 1 | 1 | X | X | X | X | 1B0000H to 1BFFFFH | 0D8000H to 0DFFFFH |
| | SA28 | 0 | 1 | 1 | 1 | 0 | 0 | X | X | X | X | 1C0000H to 1CFFFFH | 0E0000H to 0E7FFFH |
| | SA29 | 0 | 1 | 1 | 1 | 0 | 1 | X | X | X | X | 1D0000H to 1DFFFFH | 0E8000H to 0EFFFFH |
| | SA30 | 0 | 1 | 1 | 1 | 1 | 0 | X | X | X | X | 1E0000H to 1EFFFFH | 0F0000H to 0F7FFFH |
| SA31 | 0 | 1 | 1 | 1 | 1 | 1 | X | X | X | X | 1F0000H to 1FFFFFH | 0F8000H to 0FFFFFH | |

(Continued)

MB84VD2208XEA-90/MB84VD2209XEA-90

(Continued)

| Bank | Sector | Sector Address | | | | | | | | | | Address Range (BYTE mode) | Address Range (WORD mode) |
|--------|--------|----------------|-----|-----|-----|-----|-----|-----|-----|-----|--------------------|------------------------------|------------------------------|
| | | Bank Address | | | | | | | | | | | |
| | | A20 | A19 | A18 | A17 | A16 | A15 | A14 | A13 | A12 | A11 | | |
| Bank 2 | SA32 | 1 | 0 | 0 | 0 | 0 | 0 | X | X | X | X | 200000H to 20FFFFH | 100000H to 107FFFFH |
| | SA33 | 1 | 0 | 0 | 0 | 0 | 1 | X | X | X | X | 210000H to 21FFFFH | 108000H to 10FFFFH |
| | SA34 | 1 | 0 | 0 | 0 | 1 | 0 | X | X | X | X | 220000H to 22FFFFH | 110000H to 117FFFFH |
| | SA35 | 1 | 0 | 0 | 0 | 1 | 1 | X | X | X | X | 230000H to 23FFFFH | 118000H to 11FFFFH |
| | SA36 | 1 | 0 | 0 | 1 | 0 | 0 | X | X | X | X | 240000H to 24FFFFH | 120000H to 127FFFFH |
| | SA37 | 1 | 0 | 0 | 1 | 0 | 1 | X | X | X | X | 250000H to 25FFFFH | 128000H to 12FFFFH |
| | SA38 | 1 | 0 | 0 | 1 | 1 | 0 | X | X | X | X | 260000H to 26FFFFH | 130000H to 137FFFFH |
| | SA39 | 1 | 0 | 0 | 1 | 1 | 1 | X | X | X | X | 270000H to 27FFFFH | 138000H to 13FFFFH |
| | SA40 | 1 | 0 | 1 | 0 | 0 | 0 | X | X | X | X | 280000H to 28FFFFH | 140000H to 147FFFFH |
| | SA41 | 1 | 0 | 1 | 0 | 0 | 1 | X | X | X | X | 290000H to 29FFFFH | 148000H to 14FFFFH |
| | SA42 | 1 | 0 | 1 | 0 | 1 | 0 | X | X | X | X | 2A0000H to 2AFFFFH | 150000H to 157FFFFH |
| | SA43 | 1 | 0 | 1 | 0 | 1 | 1 | X | X | X | X | 2B0000H to 2BFFFFH | 158000H to 15FFFFH |
| | SA44 | 1 | 0 | 1 | 1 | 0 | 0 | X | X | X | X | 2C0000H to 2CFFFFH | 160000H to 167FFFFH |
| | SA45 | 1 | 0 | 1 | 1 | 0 | 1 | X | X | X | X | 2D0000H to 2DFFFFH | 168000H to 16FFFFH |
| | SA46 | 1 | 0 | 1 | 1 | 1 | 0 | X | X | X | X | 2E0000H to 2EFFFFH | 170000H to 177FFFFH |
| | SA47 | 1 | 0 | 1 | 1 | 1 | 1 | X | X | X | X | 2F0000H to 2FFFFH | 178000H to 17FFFFH |
| | SA48 | 1 | 1 | 0 | 0 | 0 | 0 | X | X | X | X | 300000H to 30FFFFH | 180000H to 187FFFFH |
| | SA49 | 1 | 1 | 0 | 0 | 0 | 1 | X | X | X | X | 310000H to 31FFFFH | 188000H to 18FFFFH |
| | SA50 | 1 | 1 | 0 | 0 | 1 | 0 | X | X | X | X | 320000H to 32FFFFH | 190000H to 197FFFFH |
| | SA51 | 1 | 1 | 0 | 0 | 1 | 1 | X | X | X | X | 330000H to 33FFFFH | 198000H to 19FFFFH |
| SA52 | 1 | 1 | 0 | 1 | 0 | 0 | X | X | X | X | 340000H to 34FFFFH | 1A0000H to 1A7FFFFH | |
| SA53 | 1 | 1 | 0 | 1 | 0 | 1 | X | X | X | X | 350000H to 35FFFFH | 1A8000H to 1AFFFFH | |
| SA54 | 1 | 1 | 0 | 1 | 1 | 0 | X | X | X | X | 360000H to 36FFFFH | 1B0000H to 1B7FFFFH | |
| SA55 | 1 | 1 | 0 | 1 | 1 | 1 | X | X | X | X | 370000H to 37FFFFH | 1B8000H to 1BFFFFH | |
| Bank 1 | SA56 | 1 | 1 | 1 | 0 | 0 | 0 | X | X | X | X | 380000H to 38FFFFH | 1C0000H to 1C7FFFFH |
| | SA57 | 1 | 1 | 1 | 0 | 0 | 1 | X | X | X | X | 390000H to 39FFFFH | 1C8000H to 1CFFFFH |
| | SA58 | 1 | 1 | 1 | 0 | 1 | 0 | X | X | X | X | 3A0000H to 3AFFFFH | 1D0000H to 1D7FFFFH |
| | SA59 | 1 | 1 | 1 | 0 | 1 | 1 | X | X | X | X | 3B0000H to 3BFFFFH | 1D8000H to 1DFFFFH |
| | SA60 | 1 | 1 | 1 | 1 | 0 | 0 | X | X | X | X | 3C0000H to 3CFFFFH | 1E0000H to 1E7FFFFH |
| | SA61 | 1 | 1 | 1 | 1 | 0 | 1 | X | X | X | X | 3D0000H to 3DFFFFH | 1E8000H to 1EFFFFH |
| | SA62 | 1 | 1 | 1 | 1 | 1 | 0 | X | X | X | X | 3E0000H to 3EFFFFH | 1F0000H to 1F7FFFFH |
| | SA63 | 1 | 1 | 1 | 1 | 1 | 1 | 0 | 0 | 0 | X | 3F0000H to 3F1FFFFH | 1F8000H to 1F8FFFFH |
| | SA64 | 1 | 1 | 1 | 1 | 1 | 1 | 0 | 0 | 1 | X | 3F2000H to 3F3FFFFH | 1F9000H to 1F9FFFFH |
| | SA65 | 1 | 1 | 1 | 1 | 1 | 1 | 0 | 1 | 0 | X | 3F4000H to 3F5FFFFH | 1FA000H to 1FAFFFFH |
| | SA66 | 1 | 1 | 1 | 1 | 1 | 1 | 0 | 1 | 1 | X | 3F6000H to 3F7FFFFH | 1FB000H to 1FBFFFFH |
| | SA67 | 1 | 1 | 1 | 1 | 1 | 1 | 1 | 0 | 0 | X | 3F8000H to 3F9FFFFH | 1FC000H to 1FCFFFFH |
| | SA68 | 1 | 1 | 1 | 1 | 1 | 1 | 1 | 0 | 1 | X | 3FA000H to 3FAFFFFH | 1FD000H to 1FDFFFFH |
| | SA69 | 1 | 1 | 1 | 1 | 1 | 1 | 1 | 1 | 0 | X | 3FC000H to 3FCFFFFH | 1FE000H to 1FEFFFFH |
| | SA70 | 1 | 1 | 1 | 1 | 1 | 1 | 1 | 1 | 1 | X | 3FE000H to 3FFFFH | 1FF000H to 1FFFFH |

MB84VD2208XEA-90/MB84VD2209XEA-90

Table 2. 4 Sector Address Tables (MB84VD22092EA)

| Bank | Sector | Sector Address | | | | | | | | | | Address Range (BYTE mode) | Address Range (WORD mode) | |
|--------|--------|----------------|-----|-----|-----|-----|-----|-----|-----|-----|----------------------|------------------------------|------------------------------|---------------------|
| | | Bank Address | | | | | | | | | | | | |
| | | A20 | A19 | A18 | A17 | A16 | A15 | A14 | A13 | A12 | A11 | | | |
| Bank 1 | SA0 | 0 | 0 | 0 | 0 | 0 | 0 | 0 | 0 | 0 | X | 000000H to 001FFFFH | 000000H to 000FFFFH | |
| | SA1 | 0 | 0 | 0 | 0 | 0 | 0 | 0 | 0 | 1 | X | 002000H to 003FFFFH | 001000H to 001FFFFH | |
| | SA2 | 0 | 0 | 0 | 0 | 0 | 0 | 0 | 0 | 1 | 0 | X | 004000H to 005FFFFH | 002000H to 002FFFFH |
| | SA3 | 0 | 0 | 0 | 0 | 0 | 0 | 0 | 0 | 1 | 1 | X | 006000H to 007FFFFH | 003000H to 003FFFFH |
| | SA4 | 0 | 0 | 0 | 0 | 0 | 0 | 1 | 0 | 0 | X | 008000H to 009FFFFH | 004000H to 004FFFFH | |
| | SA5 | 0 | 0 | 0 | 0 | 0 | 0 | 1 | 0 | 1 | X | 00A000H to 00BFFFFH | 005000H to 005FFFFH | |
| | SA6 | 0 | 0 | 0 | 0 | 0 | 0 | 1 | 1 | 0 | X | 00C000H to 00DFFFFH | 006000H to 006FFFFH | |
| | SA7 | 0 | 0 | 0 | 0 | 0 | 0 | 1 | 1 | 1 | X | 00E000H to 00FFFFFFH | 007000H to 007FFFFH | |
| | SA8 | 0 | 0 | 0 | 0 | 0 | 1 | X | X | X | X | 010000H to 01FFFFFFH | 008000H to 00FFFFFFH | |
| | SA9 | 0 | 0 | 0 | 0 | 1 | 0 | X | X | X | X | 020000H to 02FFFFFFH | 010000H to 017FFFFH | |
| | SA10 | 0 | 0 | 0 | 0 | 1 | 1 | X | X | X | X | 030000H to 03FFFFFFH | 018000H to 01FFFFFFH | |
| | SA11 | 0 | 0 | 0 | 1 | 0 | 0 | X | X | X | X | 040000H to 04FFFFFFH | 020000H to 027FFFFH | |
| | SA12 | 0 | 0 | 0 | 1 | 0 | 1 | X | X | X | X | 050000H to 05FFFFFFH | 028000H to 02FFFFFFH | |
| | SA13 | 0 | 0 | 0 | 1 | 1 | 0 | X | X | X | X | 060000H to 06FFFFFFH | 030000H to 037FFFFH | |
| SA14 | 0 | 0 | 0 | 1 | 1 | 1 | X | X | X | X | 070000H to 07FFFFFFH | 038000H to 03FFFFFFH | | |
| Bank 2 | SA15 | 0 | 0 | 1 | 0 | 0 | 0 | X | X | X | X | 080000H to 08FFFFFFH | 040000H to 047FFFFH | |
| | SA16 | 0 | 0 | 1 | 0 | 0 | 1 | X | X | X | X | 090000H to 09FFFFFFH | 048000H to 04FFFFFFH | |
| | SA17 | 0 | 0 | 1 | 0 | 1 | 0 | X | X | X | X | 0A0000H to 0AFFFFFFH | 050000H to 057FFFFH | |
| | SA18 | 0 | 0 | 1 | 0 | 1 | 1 | X | X | X | X | 0B0000H to 0BFFFFFFH | 058000H to 05FFFFFFH | |
| | SA19 | 0 | 0 | 1 | 1 | 0 | 0 | X | X | X | X | 0C0000H to 0CFFFFFFH | 060000H to 067FFFFH | |
| | SA20 | 0 | 0 | 1 | 1 | 0 | 1 | X | X | X | X | 0D0000H to 0DFFFFFFH | 068000H to 06FFFFFFH | |
| | SA21 | 0 | 0 | 1 | 1 | 1 | 0 | X | X | X | X | 0E0000H to 0EFFFFFFH | 070000H to 077FFFFH | |
| | SA22 | 0 | 0 | 1 | 1 | 1 | 1 | X | X | X | X | 0F0000H to 0FFFFFFH | 078000H to 07FFFFFFH | |
| | SA23 | 0 | 1 | 0 | 0 | 0 | 0 | X | X | X | X | 100000H to 10FFFFFFH | 080000H to 087FFFFH | |
| | SA24 | 0 | 1 | 0 | 0 | 0 | 1 | X | X | X | X | 110000H to 11FFFFFFH | 088000H to 08FFFFFFH | |
| | SA25 | 0 | 1 | 0 | 0 | 1 | 0 | X | X | X | X | 120000H to 12FFFFFFH | 090000H to 097FFFFH | |
| | SA26 | 0 | 1 | 0 | 0 | 1 | 1 | X | X | X | X | 130000H to 13FFFFFFH | 098000H to 09FFFFFFH | |
| | SA27 | 0 | 1 | 0 | 1 | 0 | 0 | X | X | X | X | 140000H to 14FFFFFFH | 0A0000H to 0A7FFFFH | |
| | SA28 | 0 | 1 | 0 | 1 | 0 | 1 | X | X | X | X | 150000H to 15FFFFFFH | 0A8000H to 0AFFFFFFH | |
| | SA29 | 0 | 1 | 0 | 1 | 1 | 0 | X | X | X | X | 160000H to 16FFFFFFH | 0B0000H to 0B7FFFFH | |
| | SA30 | 0 | 1 | 0 | 1 | 1 | 1 | X | X | X | X | 170000H to 17FFFFFFH | 0B8000H to 0BFFFFFFH | |
| | SA31 | 0 | 1 | 1 | 0 | 0 | 0 | X | X | X | X | 180000H to 18FFFFFFH | 0C0000H to 0C7FFFFH | |
| | SA32 | 0 | 1 | 1 | 0 | 0 | 1 | X | X | X | X | 190000H to 19FFFFFFH | 0C8000H to 0CFFFFFFH | |
| | SA33 | 0 | 1 | 1 | 0 | 1 | 0 | X | X | X | X | 1A0000H to 1AFFFFFFH | 0D0000H to 0D7FFFFH | |
| | SA34 | 0 | 1 | 1 | 0 | 1 | 1 | X | X | X | X | 1B0000H to 1BFFFFFFH | 0D8000H to 0DFFFFFFH | |
| | SA35 | 0 | 1 | 1 | 1 | 0 | 0 | X | X | X | X | 1C0000H to 1CFFFFFFH | 0E0000H to 0E7FFFFH | |
| | SA36 | 0 | 1 | 1 | 1 | 0 | 1 | X | X | X | X | 1D0000H to 1DFFFFFFH | 0E8000H to 0EFFFFFFH | |

(Continued)

MB84VD2208XEA-90/MB84VD2209XEA-90

(Continued)

| Bank | Sector | Sector Address | | | | | | | | | | Address Range (BYTE mode) | Address Range (WORD mode) |
|--------|--------|----------------|-----|-----|-----|-----|-----|-----|-----|-----|---------------------|------------------------------|------------------------------|
| | | Bank Address | | | | | | | | | | | |
| | | A20 | A19 | A18 | A17 | A16 | A15 | A14 | A13 | A12 | A11 | | |
| Bank 2 | SA37 | 0 | 1 | 1 | 1 | 1 | 0 | X | X | X | X | 1E0000H to 1EFFFFH | 0F0000H to 0F7FFFH |
| | SA38 | 0 | 1 | 1 | 1 | 1 | 1 | X | X | X | X | 1F0000H to 1FFFFFFH | 0F8000H to 0FFFFFFH |
| | SA39 | 1 | 0 | 0 | 0 | 0 | 0 | X | X | X | X | 200000H to 20FFFFH | 100000H to 107FFFH |
| | SA40 | 1 | 0 | 0 | 0 | 0 | 1 | X | X | X | X | 210000H to 21FFFFH | 108000H to 10FFFFH |
| | SA41 | 1 | 0 | 0 | 0 | 1 | 0 | X | X | X | X | 220000H to 22FFFFH | 110000H to 117FFFH |
| | SA42 | 1 | 0 | 0 | 0 | 1 | 1 | X | X | X | X | 230000H to 23FFFFH | 118000H to 11FFFFH |
| | SA43 | 1 | 0 | 0 | 1 | 0 | 0 | X | X | X | X | 240000H to 24FFFFH | 120000H to 127FFFH |
| | SA44 | 1 | 0 | 0 | 1 | 0 | 1 | X | X | X | X | 250000H to 25FFFFH | 128000H to 12FFFFH |
| | SA45 | 1 | 0 | 0 | 1 | 1 | 0 | X | X | X | X | 260000H to 26FFFFH | 130000H to 137FFFH |
| | SA46 | 1 | 0 | 0 | 1 | 1 | 1 | X | X | X | X | 270000H to 27FFFFH | 138000H to 13FFFFH |
| | SA47 | 1 | 0 | 1 | 0 | 0 | 0 | X | X | X | X | 280000H to 28FFFFH | 140000H to 147FFFH |
| | SA48 | 1 | 0 | 1 | 0 | 0 | 1 | X | X | X | X | 290000H to 29FFFFH | 148000H to 14FFFFH |
| | SA49 | 1 | 0 | 1 | 0 | 1 | 0 | X | X | X | X | 2A0000H to 2AFFFFH | 150000H to 157FFFH |
| | SA50 | 1 | 0 | 1 | 0 | 1 | 1 | X | X | X | X | 2B0000H to 2BFFFFH | 158000H to 15FFFFH |
| | SA51 | 1 | 0 | 1 | 1 | 0 | 0 | X | X | X | X | 2C0000H to 2CFFFFH | 160000H to 167FFFH |
| | SA52 | 1 | 0 | 1 | 1 | 0 | 1 | X | X | X | X | 2D0000H to 2DFFFFH | 168000H to 16FFFFH |
| | SA53 | 1 | 0 | 1 | 1 | 1 | 0 | X | X | X | X | 2E0000H to 2EFFFFH | 170000H to 177FFFH |
| | SA54 | 1 | 0 | 1 | 1 | 1 | 1 | X | X | X | X | 2F0000H to 2FFFFFFH | 178000H to 17FFFFH |
| | SA55 | 1 | 1 | 0 | 0 | 0 | 0 | X | X | X | X | 300000H to 30FFFFH | 180000H to 187FFFH |
| | SA56 | 1 | 1 | 0 | 0 | 0 | 1 | X | X | X | X | 310000H to 31FFFFH | 188000H to 18FFFFH |
| | SA57 | 1 | 1 | 0 | 0 | 1 | 0 | X | X | X | X | 320000H to 32FFFFH | 190000H to 197FFFH |
| | SA58 | 1 | 1 | 0 | 0 | 1 | 1 | X | X | X | X | 330000H to 33FFFFH | 198000H to 19FFFFH |
| | SA59 | 1 | 1 | 0 | 1 | 0 | 0 | X | X | X | X | 340000H to 34FFFFH | 1A0000H to 1A7FFFH |
| | SA60 | 1 | 1 | 0 | 1 | 0 | 1 | X | X | X | X | 350000H to 35FFFFH | 1A8000H to 1AFFFFH |
| | SA61 | 1 | 1 | 0 | 1 | 1 | 0 | X | X | X | X | 360000H to 36FFFFH | 1B0000H to 1B7FFFH |
| | SA62 | 1 | 1 | 0 | 1 | 1 | 1 | X | X | X | X | 370000H to 37FFFFH | 1B8000H to 1BFFFFH |
| | SA63 | 1 | 1 | 1 | 0 | 0 | 0 | X | X | X | X | 380000H to 38FFFFH | 1C0000H to 1C7FFFH |
| | SA64 | 1 | 1 | 1 | 0 | 0 | 1 | X | X | X | X | 390000H to 39FFFFH | 1C8000H to 1CFFFFH |
| | SA65 | 1 | 1 | 1 | 0 | 1 | 0 | X | X | X | X | 3A0000H to 3AFFFFH | 1D0000H to 1D7FFFH |
| | SA66 | 1 | 1 | 1 | 0 | 1 | 1 | X | X | X | X | 3B0000H to 3BFFFFH | 1D8000H to 1DFFFFH |
| SA67 | 1 | 1 | 1 | 1 | 0 | 0 | X | X | X | X | 3C0000H to 3CFFFFH | 1E0000H to 1E7FFFH | |
| SA68 | 1 | 1 | 1 | 1 | 0 | 1 | X | X | X | X | 3D0000H to 3DFFFFH | 1E8000H to 1EFFFFH | |
| SA69 | 1 | 1 | 1 | 1 | 1 | 0 | X | X | X | X | 3E0000H to 3EFFFFH | 1F0000H to 1F7FFFH | |
| SA70 | 1 | 1 | 1 | 1 | 1 | 1 | X | X | X | X | 3F0000H to 3FFFFFFH | 1F8000H to 1FFFFFFH | |

MB84VD2208XEA-90/MB84VD2209XEA-90

Table 2.5 Sector Address Tables (MB84VD22083EA)

| Bank | Sector | Sector Address | | | | | | | | | | Address Range (BYTE mode) | Address Range (WORD mode) |
|--------|--------|----------------|-----|-----|-----|-----|-----|-----|-----|-----|--------------------|------------------------------|------------------------------|
| | | Bank Address | | | | | | | | | | | |
| | | A20 | A19 | A18 | A17 | A16 | A15 | A14 | A13 | A12 | A11 | | |
| Bank 2 | SA0 | 0 | 0 | 0 | 0 | 0 | 0 | X | X | X | X | 000000H to 00FFFFH | 000000H to 007FFFH |
| | SA1 | 0 | 0 | 0 | 0 | 0 | 1 | X | X | X | X | 010000H to 01FFFFH | 008000H to 00FFFFH |
| | SA2 | 0 | 0 | 0 | 0 | 1 | 0 | X | X | X | X | 020000H to 02FFFFH | 010000H to 017FFFH |
| | SA3 | 0 | 0 | 0 | 0 | 1 | 1 | X | X | X | X | 030000H to 03FFFFH | 018000H to 01FFFFH |
| | SA4 | 0 | 0 | 0 | 1 | 0 | 0 | X | X | X | X | 040000H to 04FFFFH | 020000H to 027FFFH |
| | SA5 | 0 | 0 | 0 | 1 | 0 | 1 | X | X | X | X | 050000H to 05FFFFH | 028000H to 02FFFFH |
| | SA6 | 0 | 0 | 0 | 1 | 1 | 0 | X | X | X | X | 060000H to 06FFFFH | 030000H to 037FFFH |
| | SA7 | 0 | 0 | 0 | 1 | 1 | 1 | X | X | X | X | 070000H to 07FFFFH | 038000H to 03FFFFH |
| | SA8 | 0 | 0 | 1 | 0 | 0 | 0 | X | X | X | X | 080000H to 08FFFFH | 040000H to 047FFFH |
| | SA9 | 0 | 0 | 1 | 0 | 0 | 1 | X | X | X | X | 090000H to 09FFFFH | 048000H to 04FFFFH |
| | SA10 | 0 | 0 | 1 | 0 | 1 | 0 | X | X | X | X | 0A0000H to 0AFFFFH | 050000H to 057FFFH |
| | SA11 | 0 | 0 | 1 | 0 | 1 | 1 | X | X | X | X | 0B0000H to 0BFFFFH | 058000H to 05FFFFH |
| | SA12 | 0 | 0 | 1 | 1 | 0 | 0 | X | X | X | X | 0C0000H to 0CFFFFH | 060000H to 067FFFH |
| | SA13 | 0 | 0 | 1 | 1 | 0 | 1 | X | X | X | X | 0D0000H to 0DFFFFH | 068000H to 06FFFFH |
| | SA14 | 0 | 0 | 1 | 1 | 1 | 0 | X | X | X | X | 0E0000H to 0EFFFFH | 070000H to 077FFFH |
| | SA15 | 0 | 0 | 1 | 1 | 1 | 1 | X | X | X | X | 0F0000H to 0FFFFFH | 078000H to 07FFFFH |
| | SA16 | 0 | 1 | 0 | 0 | 0 | 0 | X | X | X | X | 100000H to 10FFFFH | 080000H to 087FFFH |
| | SA17 | 0 | 1 | 0 | 0 | 0 | 1 | X | X | X | X | 110000H to 11FFFFH | 088000H to 08FFFFH |
| | SA18 | 0 | 1 | 0 | 0 | 1 | 0 | X | X | X | X | 120000H to 12FFFFH | 090000H to 097FFFH |
| | SA19 | 0 | 1 | 0 | 0 | 1 | 1 | X | X | X | X | 130000H to 13FFFFH | 098000H to 09FFFFH |
| | SA20 | 0 | 1 | 0 | 1 | 0 | 0 | X | X | X | X | 140000H to 14FFFFH | 0A0000H to 0A7FFFH |
| | SA21 | 0 | 1 | 0 | 1 | 0 | 1 | X | X | X | X | 150000H to 15FFFFH | 0A8000H to 0AFFFFH |
| | SA22 | 0 | 1 | 0 | 1 | 1 | 0 | X | X | X | X | 160000H to 16FFFFH | 0B0000H to 0B7FFFH |
| | SA23 | 0 | 1 | 0 | 1 | 1 | 1 | X | X | X | X | 170000H to 17FFFFH | 0B8000H to 0BFFFFH |
| | SA24 | 0 | 1 | 1 | 0 | 0 | 0 | X | X | X | X | 180000H to 18FFFFH | 0C0000H to 0C7FFFH |
| | SA25 | 0 | 1 | 1 | 0 | 0 | 1 | X | X | X | X | 190000H to 19FFFFH | 0C8000H to 0CFFFFH |
| | SA26 | 0 | 1 | 1 | 0 | 1 | 0 | X | X | X | X | 1A0000H to 1AFFFFH | 0D0000H to 0D7FFFH |
| | SA27 | 0 | 1 | 1 | 0 | 1 | 1 | X | X | X | X | 1B0000H to 1BFFFFH | 0D8000H to 0DFFFFH |
| | SA28 | 0 | 1 | 1 | 1 | 0 | 0 | X | X | X | X | 1C0000H to 1CFFFFH | 0E0000H to 0E7FFFH |
| | SA29 | 0 | 1 | 1 | 1 | 0 | 1 | X | X | X | X | 1D0000H to 1DFFFFH | 0E8000H to 0EFFFFH |
| | SA30 | 0 | 1 | 1 | 1 | 1 | 0 | X | X | X | X | 1E0000H to 1EFFFFH | 0F0000H to 0F7FFFH |
| SA31 | 0 | 1 | 1 | 1 | 1 | 1 | X | X | X | X | 1F0000H to 1FFFFFH | 0F8000H to 0FFFFFH | |

(Continued)

MB84VD2208XEA-90/MB84VD2209XEA-90

(Continued)

| Bank | Sector | Sector Address | | | | | | | | | | Address Range (BYTE mode) | Address Range (WORD mode) |
|--------|--------|-----------------|-----------------|-----------------|-----------------|-----------------|-----------------|-----------------|-----------------|-----------------|-----------------|------------------------------|------------------------------|
| | | Bank Address | | | | | | | | | | | |
| | | A ₂₀ | A ₁₉ | A ₁₈ | A ₁₇ | A ₁₆ | A ₁₅ | A ₁₄ | A ₁₃ | A ₁₂ | A ₁₁ | | |
| Bank 2 | SA32 | 1 | 0 | 0 | 0 | 0 | 0 | X | X | X | X | 200000H to 20FFFFH | 100000H to 107FFFFH |
| | SA33 | 1 | 0 | 0 | 0 | 0 | 1 | X | X | X | X | 210000H to 21FFFFH | 108000H to 10FFFFH |
| | SA34 | 1 | 0 | 0 | 0 | 1 | 0 | X | X | X | X | 220000H to 22FFFFH | 110000H to 117FFFFH |
| | SA35 | 1 | 0 | 0 | 0 | 1 | 1 | X | X | X | X | 230000H to 23FFFFH | 118000H to 11FFFFH |
| | SA36 | 1 | 0 | 0 | 1 | 0 | 0 | X | X | X | X | 240000H to 24FFFFH | 120000H to 127FFFFH |
| | SA37 | 1 | 0 | 0 | 1 | 0 | 1 | X | X | X | X | 250000H to 25FFFFH | 128000H to 12FFFFH |
| | SA38 | 1 | 0 | 0 | 1 | 1 | 0 | X | X | X | X | 260000H to 26FFFFH | 130000H to 137FFFFH |
| | SA39 | 1 | 0 | 0 | 1 | 1 | 1 | X | X | X | X | 270000H to 27FFFFH | 138000H to 13FFFFH |
| | SA40 | 1 | 0 | 1 | 0 | 0 | 0 | X | X | X | X | 280000H to 28FFFFH | 140000H to 147FFFFH |
| | SA41 | 1 | 0 | 1 | 0 | 0 | 1 | X | X | X | X | 290000H to 29FFFFH | 148000H to 14FFFFH |
| | SA42 | 1 | 0 | 1 | 0 | 1 | 0 | X | X | X | X | 2A0000H to 2AFFFFH | 150000H to 157FFFFH |
| | SA43 | 1 | 0 | 1 | 0 | 1 | 1 | X | X | X | X | 2B0000H to 2BFFFFH | 158000H to 15FFFFH |
| | SA44 | 1 | 0 | 1 | 1 | 0 | 0 | X | X | X | X | 2C0000H to 2CFFFFH | 160000H to 167FFFFH |
| | SA45 | 1 | 0 | 1 | 1 | 0 | 1 | X | X | X | X | 2D0000H to 2DFFFFH | 168000H to 16FFFFH |
| | SA46 | 1 | 0 | 1 | 1 | 1 | 0 | X | X | X | X | 2E0000H to 2EFFFFH | 170000H to 177FFFFH |
| | SA47 | 1 | 0 | 1 | 1 | 1 | 1 | X | X | X | X | 2F0000H to 2FFFFFH | 178000H to 17FFFFH |
| Bank 1 | SA48 | 1 | 1 | 0 | 0 | 0 | 0 | X | X | X | X | 300000H to 30FFFFH | 180000H to 187FFFFH |
| | SA49 | 1 | 1 | 0 | 0 | 0 | 1 | X | X | X | X | 310000H to 31FFFFH | 188000H to 18FFFFH |
| | SA50 | 1 | 1 | 0 | 0 | 1 | 0 | X | X | X | X | 320000H to 32FFFFH | 190000H to 197FFFFH |
| | SA51 | 1 | 1 | 0 | 0 | 1 | 1 | X | X | X | X | 330000H to 33FFFFH | 198000H to 19FFFFH |
| | SA52 | 1 | 1 | 0 | 1 | 0 | 0 | X | X | X | X | 340000H to 34FFFFH | 1A0000H to 1A7FFFFH |
| | SA53 | 1 | 1 | 0 | 1 | 0 | 1 | X | X | X | X | 350000H to 35FFFFH | 1A8000H to 1AFFFFH |
| | SA54 | 1 | 1 | 0 | 1 | 1 | 0 | X | X | X | X | 360000H to 36FFFFH | 1B0000H to 1B7FFFFH |
| | SA55 | 1 | 1 | 0 | 1 | 1 | 1 | X | X | X | X | 370000H to 37FFFFH | 1B8000H to 1BFFFFH |
| | SA56 | 1 | 1 | 1 | 0 | 0 | 0 | X | X | X | X | 380000H to 38FFFFH | 1C0000H to 1C7FFFFH |
| | SA57 | 1 | 1 | 1 | 0 | 0 | 1 | X | X | X | X | 390000H to 39FFFFH | 1C8000H to 1CFFFFH |
| | SA58 | 1 | 1 | 1 | 0 | 1 | 0 | X | X | X | X | 3A0000H to 3AFFFFH | 1D0000H to 1D7FFFFH |
| | SA59 | 1 | 1 | 1 | 0 | 1 | 1 | X | X | X | X | 3B0000H to 3BFFFFH | 1D8000H to 1DFFFFH |
| | SA60 | 1 | 1 | 1 | 1 | 0 | 0 | X | X | X | X | 3C0000H to 3CFFFFH | 1E0000H to 1E7FFFFH |
| | SA61 | 1 | 1 | 1 | 1 | 0 | 1 | X | X | X | X | 3D0000H to 3DFFFFH | 1E8000H to 1EFFFFH |
| | SA62 | 1 | 1 | 1 | 1 | 1 | 0 | X | X | X | X | 3E0000H to 3EFFFFH | 1F0000H to 1F7FFFFH |
| | SA63 | 1 | 1 | 1 | 1 | 1 | 1 | 0 | 0 | 0 | X | 3F0000H to 3F1FFFFH | 1F8000H to 1F8FFFFH |
| | SA64 | 1 | 1 | 1 | 1 | 1 | 1 | 0 | 0 | 1 | X | 3F2000H to 3F3FFFFH | 1F9000H to 1F9FFFFH |
| | SA65 | 1 | 1 | 1 | 1 | 1 | 1 | 0 | 1 | 0 | X | 3F4000H to 3F5FFFFH | 1FA000H to 1FAFFFFH |
| | SA66 | 1 | 1 | 1 | 1 | 1 | 1 | 0 | 1 | 1 | X | 3F6000H to 3F7FFFFH | 1FB000H to 1FBFFFFH |
| | SA67 | 1 | 1 | 1 | 1 | 1 | 1 | 1 | 0 | 0 | X | 3F8000H to 3F9FFFFH | 1FC000H to 1FCFFFFH |
| | SA68 | 1 | 1 | 1 | 1 | 1 | 1 | 1 | 0 | 1 | X | 3FA000H to 3FAFFFFH | 1FD000H to 1FDFFFFH |
| | SA69 | 1 | 1 | 1 | 1 | 1 | 1 | 1 | 1 | 0 | X | 3FC000H to 3FCFFFFH | 1FE000H to 1FEFFFFH |
| | SA70 | 1 | 1 | 1 | 1 | 1 | 1 | 1 | 1 | 1 | X | 3FE000H to 3FFFFFH | 1FF000H to 1FFFFFH |

MB84VD2208XEA-90/MB84VD2209XEA-90

Table 2. 6 Sector Address Tables (MB84VD22093EA)

| Bank | Sector | Sector Address | | | | | | | | | | Address Range (BYTE mode) | Address Range (WORD mode) | |
|--------|--------|----------------|-----|-----|-----|-----|-----|-----|-----|-----|-----|------------------------------|------------------------------|----------------------|
| | | Bank Address | | | | | | | | | | | | |
| | | A20 | A19 | A18 | A17 | A16 | A15 | A14 | A13 | A12 | A11 | | | |
| Bank 1 | SA0 | 0 | 0 | 0 | 0 | 0 | 0 | 0 | 0 | 0 | X | 000000H to 001FFFFH | 000000H to 000FFFFH | |
| | SA1 | 0 | 0 | 0 | 0 | 0 | 0 | 0 | 0 | 1 | X | 002000H to 003FFFFH | 001000H to 001FFFFH | |
| | SA2 | 0 | 0 | 0 | 0 | 0 | 0 | 0 | 0 | 1 | 0 | X | 004000H to 005FFFFH | 002000H to 002FFFFH |
| | SA3 | 0 | 0 | 0 | 0 | 0 | 0 | 0 | 0 | 1 | 1 | X | 006000H to 007FFFFH | 003000H to 003FFFFH |
| | SA4 | 0 | 0 | 0 | 0 | 0 | 0 | 0 | 1 | 0 | 0 | X | 008000H to 009FFFFH | 004000H to 004FFFFH |
| | SA5 | 0 | 0 | 0 | 0 | 0 | 0 | 0 | 1 | 0 | 1 | X | 00A000H to 00BFFFFH | 005000H to 005FFFFH |
| | SA6 | 0 | 0 | 0 | 0 | 0 | 0 | 0 | 1 | 1 | 0 | X | 00C000H to 00DFFFFH | 006000H to 006FFFFH |
| | SA7 | 0 | 0 | 0 | 0 | 0 | 0 | 0 | 1 | 1 | 1 | X | 00E000H to 00FFFFFFH | 007000H to 007FFFFH |
| | SA8 | 0 | 0 | 0 | 0 | 0 | 0 | 1 | X | X | X | X | 010000H to 01FFFFFFH | 008000H to 00FFFFFFH |
| | SA9 | 0 | 0 | 0 | 0 | 0 | 1 | 0 | X | X | X | X | 020000H to 02FFFFFFH | 010000H to 017FFFFH |
| | SA10 | 0 | 0 | 0 | 0 | 0 | 1 | 1 | X | X | X | X | 030000H to 03FFFFFFH | 018000H to 01FFFFFFH |
| | SA11 | 0 | 0 | 0 | 0 | 1 | 0 | 0 | X | X | X | X | 040000H to 04FFFFFFH | 020000H to 027FFFFH |
| | SA12 | 0 | 0 | 0 | 0 | 1 | 0 | 1 | X | X | X | X | 050000H to 05FFFFFFH | 028000H to 02FFFFFFH |
| | SA13 | 0 | 0 | 0 | 0 | 1 | 1 | 0 | X | X | X | X | 060000H to 06FFFFFFH | 030000H to 037FFFFH |
| | SA14 | 0 | 0 | 0 | 0 | 1 | 1 | 1 | X | X | X | X | 070000H to 07FFFFFFH | 038000H to 03FFFFFFH |
| | SA15 | 0 | 0 | 0 | 1 | 0 | 0 | 0 | X | X | X | X | 080000H to 08FFFFFFH | 040000H to 047FFFFH |
| | SA16 | 0 | 0 | 0 | 1 | 0 | 0 | 1 | X | X | X | X | 090000H to 09FFFFFFH | 048000H to 04FFFFFFH |
| | SA17 | 0 | 0 | 0 | 1 | 0 | 1 | 0 | X | X | X | X | 0A0000H to 0AFFFFFFH | 050000H to 057FFFFH |
| | SA18 | 0 | 0 | 0 | 1 | 0 | 1 | 1 | X | X | X | X | 0B0000H to 0BFFFFFFH | 058000H to 05FFFFFFH |
| | SA19 | 0 | 0 | 0 | 1 | 1 | 0 | 0 | X | X | X | X | 0C0000H to 0CFFFFFFH | 060000H to 067FFFFH |
| | SA20 | 0 | 0 | 0 | 1 | 1 | 0 | 1 | X | X | X | X | 0D0000H to 0DFFFFFFH | 068000H to 06FFFFFFH |
| | SA21 | 0 | 0 | 0 | 1 | 1 | 1 | 0 | X | X | X | X | 0E0000H to 0EFFFFFFH | 070000H to 077FFFFH |
| SA22 | 0 | 0 | 0 | 1 | 1 | 1 | 1 | X | X | X | X | 0F0000H to 0FFFFFFH | 078000H to 07FFFFFFH | |
| Bank 2 | SA23 | 0 | 1 | 0 | 0 | 0 | 0 | X | X | X | X | 100000H to 10FFFFFFH | 080000H to 087FFFFH | |
| | SA24 | 0 | 1 | 0 | 0 | 0 | 1 | X | X | X | X | 110000H to 11FFFFFFH | 088000H to 08FFFFFFH | |
| | SA25 | 0 | 1 | 0 | 0 | 0 | 1 | 0 | X | X | X | X | 120000H to 12FFFFFFH | 090000H to 097FFFFH |
| | SA26 | 0 | 1 | 0 | 0 | 0 | 1 | 1 | X | X | X | X | 130000H to 13FFFFFFH | 098000H to 09FFFFFFH |
| | SA27 | 0 | 1 | 0 | 0 | 1 | 0 | 0 | X | X | X | X | 140000H to 14FFFFFFH | 0A0000H to 0A7FFFFH |
| | SA28 | 0 | 1 | 0 | 0 | 1 | 0 | 1 | X | X | X | X | 150000H to 15FFFFFFH | 0A8000H to 0AFFFFFFH |
| | SA29 | 0 | 1 | 0 | 0 | 1 | 1 | 0 | X | X | X | X | 160000H to 16FFFFFFH | 0B0000H to 0B7FFFFH |
| | SA30 | 0 | 1 | 0 | 0 | 1 | 1 | 1 | X | X | X | X | 170000H to 17FFFFFFH | 0B8000H to 0BFFFFFFH |
| | SA31 | 0 | 1 | 0 | 0 | 0 | 0 | 0 | X | X | X | X | 180000H to 18FFFFFFH | 0C0000H to 0C7FFFFH |
| | SA32 | 0 | 1 | 0 | 0 | 0 | 1 | 0 | X | X | X | X | 190000H to 19FFFFFFH | 0C8000H to 0CFFFFFFH |
| | SA33 | 0 | 1 | 0 | 0 | 1 | 0 | 0 | X | X | X | X | 1A0000H to 1AFFFFFFH | 0D0000H to 0D7FFFFH |
| | SA34 | 0 | 1 | 0 | 0 | 1 | 1 | 0 | X | X | X | X | 1B0000H to 1BFFFFFFH | 0D8000H to 0DFFFFFFH |
| | SA35 | 0 | 1 | 0 | 0 | 1 | 0 | 0 | X | X | X | X | 1C0000H to 1CFFFFFFH | 0E0000H to 0E7FFFFH |
| | SA36 | 0 | 1 | 0 | 0 | 1 | 0 | 1 | X | X | X | X | 1D0000H to 1DFFFFFFH | 0E8000H to 0EFFFFFFH |

(Continued)

MB84VD2208XEA-90/MB84VD2209XEA-90

(Continued)

| Bank | Sector | Sector Address | | | | | | | | | | Address Range (BYTE mode) | Address Range (WORD mode) |
|--------|--------|----------------|-----|-----|-----|-----|-----|-----|-----|-----|---------------------|------------------------------|------------------------------|
| | | Bank Address | | | | | | | | | | | |
| | | A20 | A19 | A18 | A17 | A16 | A15 | A14 | A13 | A12 | A11 | | |
| Bank 2 | SA37 | 0 | 1 | 1 | 1 | 1 | 0 | X | X | X | X | 1E0000H to 1EFFFFH | 0F0000H to 0F7FFFH |
| | SA38 | 0 | 1 | 1 | 1 | 1 | 1 | X | X | X | X | 1F0000H to 1FFFFFH | 0F8000H to 0FFFFFFH |
| | SA39 | 1 | 0 | 0 | 0 | 0 | 0 | X | X | X | X | 200000H to 20FFFFH | 100000H to 107FFFH |
| | SA40 | 1 | 0 | 0 | 0 | 0 | 1 | X | X | X | X | 210000H to 21FFFFH | 108000H to 10FFFFH |
| | SA41 | 1 | 0 | 0 | 0 | 1 | 0 | X | X | X | X | 220000H to 22FFFFH | 110000H to 117FFFH |
| | SA42 | 1 | 0 | 0 | 0 | 1 | 1 | X | X | X | X | 230000H to 23FFFFH | 118000H to 11FFFFH |
| | SA43 | 1 | 0 | 0 | 1 | 0 | 0 | X | X | X | X | 240000H to 24FFFFH | 120000H to 127FFFH |
| | SA44 | 1 | 0 | 0 | 1 | 0 | 1 | X | X | X | X | 250000H to 25FFFFH | 128000H to 12FFFFH |
| | SA45 | 1 | 0 | 0 | 1 | 1 | 0 | X | X | X | X | 260000H to 26FFFFH | 130000H to 137FFFH |
| | SA46 | 1 | 0 | 0 | 1 | 1 | 1 | X | X | X | X | 270000H to 27FFFFH | 138000H to 13FFFFH |
| | SA47 | 1 | 0 | 1 | 0 | 0 | 0 | X | X | X | X | 280000H to 28FFFFH | 140000H to 147FFFH |
| | SA48 | 1 | 0 | 1 | 0 | 0 | 1 | X | X | X | X | 290000H to 29FFFFH | 148000H to 14FFFFH |
| | SA49 | 1 | 0 | 1 | 0 | 1 | 0 | X | X | X | X | 2A0000H to 2AFFFFH | 150000H to 157FFFH |
| | SA50 | 1 | 0 | 1 | 0 | 1 | 1 | X | X | X | X | 2B0000H to 2BFFFFH | 158000H to 15FFFFH |
| | SA51 | 1 | 0 | 1 | 1 | 0 | 0 | X | X | X | X | 2C0000H to 2CFFFFH | 160000H to 167FFFH |
| | SA52 | 1 | 0 | 1 | 1 | 0 | 1 | X | X | X | X | 2D0000H to 2DFFFFH | 168000H to 16FFFFH |
| | SA53 | 1 | 0 | 1 | 1 | 1 | 0 | X | X | X | X | 2E0000H to 2EFFFFH | 170000H to 177FFFH |
| | SA54 | 1 | 0 | 1 | 1 | 1 | 1 | X | X | X | X | 2F0000H to 2FFFFFH | 178000H to 17FFFFH |
| | SA55 | 1 | 1 | 0 | 0 | 0 | 0 | X | X | X | X | 300000H to 30FFFFH | 180000H to 187FFFH |
| | SA56 | 1 | 1 | 0 | 0 | 0 | 1 | X | X | X | X | 310000H to 31FFFFH | 188000H to 18FFFFH |
| | SA57 | 1 | 1 | 0 | 0 | 1 | 0 | X | X | X | X | 320000H to 32FFFFH | 190000H to 197FFFH |
| | SA58 | 1 | 1 | 0 | 0 | 1 | 1 | X | X | X | X | 330000H to 33FFFFH | 198000H to 19FFFFH |
| | SA59 | 1 | 1 | 0 | 1 | 0 | 0 | X | X | X | X | 340000H to 34FFFFH | 1A0000H to 1A7FFFH |
| | SA60 | 1 | 1 | 0 | 1 | 0 | 1 | X | X | X | X | 350000H to 35FFFFH | 1A8000H to 1AFFFFH |
| | SA61 | 1 | 1 | 0 | 1 | 1 | 0 | X | X | X | X | 360000H to 36FFFFH | 1B0000H to 1B7FFFH |
| | SA62 | 1 | 1 | 0 | 1 | 1 | 1 | X | X | X | X | 370000H to 37FFFFH | 1B8000H to 1BFFFFH |
| | SA63 | 1 | 1 | 1 | 0 | 0 | 0 | X | X | X | X | 380000H to 38FFFFH | 1C0000H to 1C7FFFH |
| | SA64 | 1 | 1 | 1 | 0 | 0 | 1 | X | X | X | X | 390000H to 39FFFFH | 1C8000H to 1CFFFFH |
| | SA65 | 1 | 1 | 1 | 0 | 1 | 0 | X | X | X | X | 3A0000H to 3AFFFFH | 1D0000H to 1D7FFFH |
| | SA66 | 1 | 1 | 1 | 0 | 1 | 1 | X | X | X | X | 3B0000H to 3BFFFFH | 1D8000H to 1DFFFFH |
| SA67 | 1 | 1 | 1 | 1 | 0 | 0 | X | X | X | X | 3C0000H to 3CFFFFH | 1E0000H to 1E7FFFH | |
| SA68 | 1 | 1 | 1 | 1 | 0 | 1 | X | X | X | X | 3D0000H to 3DFFFFH | 1E8000H to 1EFFFFH | |
| SA69 | 1 | 1 | 1 | 1 | 1 | 0 | X | X | X | X | 3E0000H to 3EFFFFH | 1F0000H to 1F7FFFH | |
| SA70 | 1 | 1 | 1 | 1 | 1 | 1 | X | X | X | X | 3F0000H to 3FFFFFFH | 1F8000H to 1FFFFFFH | |

MB84VD2208XEA-90/MB84VD2209XEA-90

Table 2.7 Sector Address Tables (MB84VD22084EA)

| Bank | Sector | Sector Address | | | | | | | | | | Address Range (BYTE mode) | Address Range (WORD mode) |
|--------|--------|-----------------|-----------------|-----------------|-----------------|-----------------|-----------------|-----------------|-----------------|-----------------|--------------------|------------------------------|------------------------------|
| | | Bank Address | | | | | | | | | | | |
| | | A ₂₀ | A ₁₉ | A ₁₈ | A ₁₇ | A ₁₆ | A ₁₅ | A ₁₄ | A ₁₃ | A ₁₂ | A ₁₁ | | |
| Bank 2 | SA0 | 0 | 0 | 0 | 0 | 0 | 0 | X | X | X | X | 000000H to 00FFFFH | 000000H to 007FFFH |
| | SA1 | 0 | 0 | 0 | 0 | 0 | 1 | X | X | X | X | 010000H to 01FFFFH | 008000H to 00FFFFH |
| | SA2 | 0 | 0 | 0 | 0 | 1 | 0 | X | X | X | X | 020000H to 02FFFFH | 010000H to 017FFFH |
| | SA3 | 0 | 0 | 0 | 0 | 1 | 1 | X | X | X | X | 030000H to 03FFFFH | 018000H to 01FFFFH |
| | SA4 | 0 | 0 | 0 | 1 | 0 | 0 | X | X | X | X | 040000H to 04FFFFH | 020000H to 027FFFH |
| | SA5 | 0 | 0 | 0 | 1 | 0 | 1 | X | X | X | X | 050000H to 05FFFFH | 028000H to 02FFFFH |
| | SA6 | 0 | 0 | 0 | 1 | 1 | 0 | X | X | X | X | 060000H to 06FFFFH | 030000H to 037FFFH |
| | SA7 | 0 | 0 | 0 | 1 | 1 | 1 | X | X | X | X | 070000H to 07FFFFH | 038000H to 03FFFFH |
| | SA8 | 0 | 0 | 1 | 0 | 0 | 0 | X | X | X | X | 080000H to 08FFFFH | 040000H to 047FFFH |
| | SA9 | 0 | 0 | 1 | 0 | 0 | 1 | X | X | X | X | 090000H to 09FFFFH | 048000H to 04FFFFH |
| | SA10 | 0 | 0 | 1 | 0 | 1 | 0 | X | X | X | X | 0A0000H to 0AFFFFH | 050000H to 057FFFH |
| | SA11 | 0 | 0 | 1 | 0 | 1 | 1 | X | X | X | X | 0B0000H to 0BFFFFH | 058000H to 05FFFFH |
| | SA12 | 0 | 0 | 1 | 1 | 0 | 0 | X | X | X | X | 0C0000H to 0CFFFFH | 060000H to 067FFFH |
| | SA13 | 0 | 0 | 1 | 1 | 0 | 1 | X | X | X | X | 0D0000H to 0DFFFFH | 068000H to 06FFFFH |
| | SA14 | 0 | 0 | 1 | 1 | 1 | 0 | X | X | X | X | 0E0000H to 0EFFFFH | 070000H to 077FFFH |
| | SA15 | 0 | 0 | 1 | 1 | 1 | 1 | X | X | X | X | 0F0000H to 0FFFFFH | 078000H to 07FFFFH |
| | SA16 | 0 | 1 | 0 | 0 | 0 | 0 | X | X | X | X | 100000H to 10FFFFH | 080000H to 087FFFH |
| | SA17 | 0 | 1 | 0 | 0 | 0 | 1 | X | X | X | X | 110000H to 11FFFFH | 088000H to 08FFFFH |
| | SA18 | 0 | 1 | 0 | 0 | 1 | 0 | X | X | X | X | 120000H to 12FFFFH | 090000H to 097FFFH |
| | SA19 | 0 | 1 | 0 | 0 | 1 | 1 | X | X | X | X | 130000H to 13FFFFH | 098000H to 09FFFFH |
| | SA20 | 0 | 1 | 0 | 1 | 0 | 0 | X | X | X | X | 140000H to 14FFFFH | 0A0000H to 0A7FFFH |
| | SA21 | 0 | 1 | 0 | 1 | 0 | 1 | X | X | X | X | 150000H to 15FFFFH | 0A8000H to 0AFFFFH |
| | SA22 | 0 | 1 | 0 | 1 | 1 | 0 | X | X | X | X | 160000H to 16FFFFH | 0B0000H to 0B7FFFH |
| | SA23 | 0 | 1 | 0 | 1 | 1 | 1 | X | X | X | X | 170000H to 17FFFFH | 0B8000H to 0BFFFFH |
| | SA24 | 0 | 1 | 1 | 0 | 0 | 0 | X | X | X | X | 180000H to 18FFFFH | 0C0000H to 0C7FFFH |
| | SA25 | 0 | 1 | 1 | 0 | 0 | 1 | X | X | X | X | 190000H to 19FFFFH | 0C8000H to 0CFFFFH |
| | SA26 | 0 | 1 | 1 | 0 | 1 | 0 | X | X | X | X | 1A0000H to 1AFFFFH | 0D0000H to 0D7FFFH |
| | SA27 | 0 | 1 | 1 | 0 | 1 | 1 | X | X | X | X | 1B0000H to 1BFFFFH | 0D8000H to 0DFFFFH |
| | SA28 | 0 | 1 | 1 | 1 | 0 | 0 | X | X | X | X | 1C0000H to 1CFFFFH | 0E0000H to 0E7FFFH |
| | SA29 | 0 | 1 | 1 | 1 | 0 | 1 | X | X | X | X | 1D0000H to 1DFFFFH | 0E8000H to 0EFFFFH |
| | SA30 | 0 | 1 | 1 | 1 | 1 | 0 | X | X | X | X | 1E0000H to 1EFFFFH | 0F0000H to 0F7FFFH |
| SA31 | 0 | 1 | 1 | 1 | 1 | 1 | X | X | X | X | 1F0000H to 1FFFFFH | 0F8000H to 0FFFFFH | |

(Continued)

MB84VD2208XEA-90/MB84VD2209XEA-90

(Continued)

| Bank | Sector | Sector Address | | | | | | | | | | Address Range (BYTE mode) | Address Range (WORD mode) |
|--------|--------|-----------------|-----------------|-----------------|-----------------|-----------------|-----------------|-----------------|-----------------|-----------------|---------------------|------------------------------|------------------------------|
| | | Bank Address | | | | | | | | | | | |
| | | A ₂₀ | A ₁₉ | A ₁₈ | A ₁₇ | A ₁₆ | A ₁₅ | A ₁₄ | A ₁₃ | A ₁₂ | A ₁₁ | | |
| Bank 1 | SA32 | 1 | 0 | 0 | 0 | 0 | 0 | X | X | X | X | 200000H to 20FFFFH | 100000H to 107FFFH |
| | SA33 | 1 | 0 | 0 | 0 | 0 | 1 | X | X | X | X | 210000H to 21FFFFH | 108000H to 10FFFFH |
| | SA34 | 1 | 0 | 0 | 0 | 1 | 0 | X | X | X | X | 220000H to 22FFFFH | 110000H to 117FFFH |
| | SA35 | 1 | 0 | 0 | 0 | 1 | 1 | X | X | X | X | 230000H to 23FFFFH | 118000H to 11FFFFH |
| | SA36 | 1 | 0 | 0 | 1 | 0 | 0 | X | X | X | X | 240000H to 24FFFFH | 120000H to 127FFFH |
| | SA37 | 1 | 0 | 0 | 1 | 0 | 1 | X | X | X | X | 250000H to 25FFFFH | 128000H to 12FFFFH |
| | SA38 | 1 | 0 | 0 | 1 | 1 | 0 | X | X | X | X | 260000H to 26FFFFH | 130000H to 137FFFH |
| | SA39 | 1 | 0 | 0 | 1 | 1 | 1 | X | X | X | X | 270000H to 27FFFFH | 138000H to 13FFFFH |
| | SA40 | 1 | 0 | 1 | 0 | 0 | 0 | X | X | X | X | 280000H to 28FFFFH | 140000H to 147FFFH |
| | SA41 | 1 | 0 | 1 | 0 | 0 | 1 | X | X | X | X | 290000H to 29FFFFH | 148000H to 14FFFFH |
| | SA42 | 1 | 0 | 1 | 0 | 1 | 0 | X | X | X | X | 2A0000H to 2AFFFFH | 150000H to 157FFFH |
| | SA43 | 1 | 0 | 1 | 0 | 1 | 1 | X | X | X | X | 2B0000H to 2BFFFFH | 158000H to 15FFFFH |
| | SA44 | 1 | 0 | 1 | 1 | 0 | 0 | X | X | X | X | 2C0000H to 2CFFFFH | 160000H to 167FFFH |
| | SA45 | 1 | 0 | 1 | 1 | 0 | 1 | X | X | X | X | 2D0000H to 2DFFFFH | 168000H to 16FFFFH |
| | SA46 | 1 | 0 | 1 | 1 | 1 | 0 | X | X | X | X | 2E0000H to 2EFFFFH | 170000H to 177FFFH |
| | SA47 | 1 | 0 | 1 | 1 | 1 | 1 | X | X | X | X | 2F0000H to 2FFFFFH | 178000H to 17FFFFH |
| | SA48 | 1 | 1 | 0 | 0 | 0 | 0 | X | X | X | X | 300000H to 30FFFFH | 180000H to 187FFFH |
| | SA49 | 1 | 1 | 0 | 0 | 0 | 1 | X | X | X | X | 310000H to 31FFFFH | 188000H to 18FFFFH |
| | SA50 | 1 | 1 | 0 | 0 | 1 | 0 | X | X | X | X | 320000H to 32FFFFH | 190000H to 197FFFH |
| | SA51 | 1 | 1 | 0 | 0 | 1 | 1 | X | X | X | X | 330000H to 33FFFFH | 198000H to 19FFFFH |
| | SA52 | 1 | 1 | 0 | 1 | 0 | 0 | X | X | X | X | 340000H to 34FFFFH | 1A0000H to 1A7FFFH |
| | SA53 | 1 | 1 | 0 | 1 | 0 | 1 | X | X | X | X | 350000H to 35FFFFH | 1A8000H to 1AFFFFH |
| | SA54 | 1 | 1 | 0 | 1 | 1 | 0 | X | X | X | X | 360000H to 36FFFFH | 1B0000H to 1B7FFFH |
| | SA55 | 1 | 1 | 0 | 1 | 1 | 1 | X | X | X | X | 370000H to 37FFFFH | 1B8000H to 1BFFFFH |
| | SA56 | 1 | 1 | 1 | 0 | 0 | 0 | X | X | X | X | 380000H to 38FFFFH | 1C0000H to 1C7FFFH |
| | SA57 | 1 | 1 | 1 | 0 | 0 | 1 | X | X | X | X | 390000H to 39FFFFH | 1C8000H to 1CFFFFH |
| | SA58 | 1 | 1 | 1 | 0 | 1 | 0 | X | X | X | X | 3A0000H to 3AFFFFH | 1D0000H to 1D7FFFH |
| | SA59 | 1 | 1 | 1 | 0 | 1 | 1 | X | X | X | X | 3B0000H to 3BFFFFH | 1D8000H to 1DFFFFH |
| | SA60 | 1 | 1 | 1 | 1 | 0 | 0 | X | X | X | X | 3C0000H to 3CFFFFH | 1E0000H to 1E7FFFH |
| | SA61 | 1 | 1 | 1 | 1 | 0 | 1 | X | X | X | X | 3D0000H to 3DFFFFH | 1E8000H to 1EFFFFH |
| SA62 | 1 | 1 | 1 | 1 | 1 | 0 | X | X | X | X | 3E0000H to 3EFFFFH | 1F0000H to 1F7FFFH | |
| SA63 | 1 | 1 | 1 | 1 | 1 | 1 | 0 | 0 | 0 | X | 3F0000H to 3F1FFFH | 1F8000H to 1F8FFFH | |
| SA64 | 1 | 1 | 1 | 1 | 1 | 1 | 0 | 0 | 1 | X | 3F2000H to 3F3FFFH | 1F9000H to 1F9FFFH | |
| SA65 | 1 | 1 | 1 | 1 | 1 | 1 | 0 | 1 | 0 | X | 3F4000H to 3F5FFFH | 1FA000H to 1FAFFFH | |
| SA66 | 1 | 1 | 1 | 1 | 1 | 1 | 0 | 1 | 1 | X | 3F6000H to 3F7FFFH | 1FB000H to 1FBFFFH | |
| SA67 | 1 | 1 | 1 | 1 | 1 | 1 | 1 | 0 | 0 | X | 3F8000H to 3F9FFFH | 1FC000H to 1FCFFFH | |
| SA68 | 1 | 1 | 1 | 1 | 1 | 1 | 1 | 0 | 1 | X | 3FA000H to 3FAFFFH | 1FD000H to 1FDFFFH | |
| SA69 | 1 | 1 | 1 | 1 | 1 | 1 | 1 | 1 | 0 | X | 3FC000H to 3FCFFFH | 1FE000H to 1FEFFFH | |
| SA70 | 1 | 1 | 1 | 1 | 1 | 1 | 1 | 1 | 1 | X | 3FE000H to 3FFFFFFH | 1FF000H to 1FFFFFFH | |

MB84VD2208XEA-90/MB84VD2209XEA-90

Table 2. 8 Sector Address Tables (MB84VD22094EA)

| Bank | Sector | Sector Address | | | | | | | | | | Address Range (BYTE mode) | Address Range (WORD mode) | |
|--------|--------|----------------|-----|-----|-----|-----|-----|-----|-----|-----|-----|------------------------------|------------------------------|----------------------|
| | | Bank Address | | | | | | | | | | | | |
| | | A20 | A19 | A18 | A17 | A16 | A15 | A14 | A13 | A12 | A11 | | | |
| Bank 1 | SA0 | 0 | 0 | 0 | 0 | 0 | 0 | 0 | 0 | 0 | X | 000000H to 001FFFFH | 000000H to 000FFFFH | |
| | SA1 | 0 | 0 | 0 | 0 | 0 | 0 | 0 | 0 | 1 | X | 002000H to 003FFFFH | 001000H to 001FFFFH | |
| | SA2 | 0 | 0 | 0 | 0 | 0 | 0 | 0 | 0 | 1 | 0 | X | 004000H to 005FFFFH | 002000H to 002FFFFH |
| | SA3 | 0 | 0 | 0 | 0 | 0 | 0 | 0 | 0 | 1 | 1 | X | 006000H to 007FFFFH | 003000H to 003FFFFH |
| | SA4 | 0 | 0 | 0 | 0 | 0 | 0 | 0 | 1 | 0 | 0 | X | 008000H to 009FFFFH | 004000H to 004FFFFH |
| | SA5 | 0 | 0 | 0 | 0 | 0 | 0 | 0 | 1 | 0 | 1 | X | 00A000H to 00BFFFFH | 005000H to 005FFFFH |
| | SA6 | 0 | 0 | 0 | 0 | 0 | 0 | 0 | 1 | 1 | 0 | X | 00C000H to 00DFFFFH | 006000H to 006FFFFH |
| | SA7 | 0 | 0 | 0 | 0 | 0 | 0 | 0 | 1 | 1 | 1 | X | 00E000H to 00FFFFFFH | 007000H to 007FFFFH |
| | SA8 | 0 | 0 | 0 | 0 | 0 | 0 | 1 | X | X | X | X | 010000H to 01FFFFFFH | 008000H to 00FFFFFFH |
| | SA9 | 0 | 0 | 0 | 0 | 0 | 1 | 0 | X | X | X | X | 020000H to 02FFFFFFH | 010000H to 017FFFFH |
| | SA10 | 0 | 0 | 0 | 0 | 0 | 1 | 1 | X | X | X | X | 030000H to 03FFFFFFH | 018000H to 01FFFFFFH |
| | SA11 | 0 | 0 | 0 | 0 | 1 | 0 | 0 | X | X | X | X | 040000H to 04FFFFFFH | 020000H to 027FFFFH |
| | SA12 | 0 | 0 | 0 | 0 | 1 | 0 | 1 | X | X | X | X | 050000H to 05FFFFFFH | 028000H to 02FFFFFFH |
| | SA13 | 0 | 0 | 0 | 0 | 1 | 1 | 0 | X | X | X | X | 060000H to 06FFFFFFH | 030000H to 037FFFFH |
| | SA14 | 0 | 0 | 0 | 0 | 1 | 1 | 1 | X | X | X | X | 070000H to 07FFFFFFH | 038000H to 03FFFFFFH |
| | SA15 | 0 | 0 | 0 | 1 | 0 | 0 | 0 | X | X | X | X | 080000H to 08FFFFFFH | 040000H to 047FFFFH |
| | SA16 | 0 | 0 | 0 | 1 | 0 | 0 | 1 | X | X | X | X | 090000H to 09FFFFFFH | 048000H to 04FFFFFFH |
| | SA17 | 0 | 0 | 0 | 1 | 0 | 1 | 0 | X | X | X | X | 0A0000H to 0AFFFFFFH | 050000H to 057FFFFH |
| | SA18 | 0 | 0 | 0 | 1 | 0 | 1 | 1 | X | X | X | X | 0B0000H to 0BFFFFFFH | 058000H to 05FFFFFFH |
| | SA19 | 0 | 0 | 0 | 1 | 1 | 0 | 0 | X | X | X | X | 0C0000H to 0CFFFFFFH | 060000H to 067FFFFH |
| | SA20 | 0 | 0 | 0 | 1 | 1 | 0 | 1 | X | X | X | X | 0D0000H to 0DFFFFFFH | 068000H to 06FFFFFFH |
| | SA21 | 0 | 0 | 0 | 1 | 1 | 1 | 0 | X | X | X | X | 0E0000H to 0EFFFFFFH | 070000H to 077FFFFH |
| | SA22 | 0 | 0 | 0 | 1 | 1 | 1 | 1 | X | X | X | X | 0F0000H to 0FFFFFFH | 078000H to 07FFFFFFH |
| | SA23 | 0 | 0 | 1 | 0 | 0 | 0 | 0 | X | X | X | X | 100000H to 10FFFFFFH | 080000H to 087FFFFH |
| | SA24 | 0 | 0 | 1 | 0 | 0 | 0 | 1 | X | X | X | X | 110000H to 11FFFFFFH | 088000H to 08FFFFFFH |
| | SA25 | 0 | 0 | 1 | 0 | 0 | 1 | 0 | X | X | X | X | 120000H to 12FFFFFFH | 090000H to 097FFFFH |
| | SA26 | 0 | 0 | 1 | 0 | 0 | 1 | 1 | X | X | X | X | 130000H to 13FFFFFFH | 098000H to 09FFFFFFH |
| | SA27 | 0 | 0 | 1 | 0 | 1 | 0 | 0 | X | X | X | X | 140000H to 14FFFFFFH | 0A0000H to 0A7FFFFH |
| | SA28 | 0 | 0 | 1 | 0 | 1 | 0 | 1 | X | X | X | X | 150000H to 15FFFFFFH | 0A8000H to 0AFFFFFFH |
| | SA29 | 0 | 0 | 1 | 0 | 1 | 1 | 0 | X | X | X | X | 160000H to 16FFFFFFH | 0B0000H to 0B7FFFFH |
| | SA30 | 0 | 0 | 1 | 0 | 1 | 1 | 1 | X | X | X | X | 170000H to 17FFFFFFH | 0B8000H to 0BFFFFFFH |
| | SA31 | 0 | 0 | 1 | 1 | 0 | 0 | 0 | X | X | X | X | 180000H to 18FFFFFFH | 0C0000H to 0C7FFFFH |
| | SA32 | 0 | 0 | 1 | 1 | 0 | 0 | 1 | X | X | X | X | 190000H to 19FFFFFFH | 0C8000H to 0CFFFFFFH |
| | SA33 | 0 | 0 | 1 | 1 | 0 | 1 | 0 | X | X | X | X | 1A0000H to 1AFFFFFFH | 0D0000H to 0D7FFFFH |
| | SA34 | 0 | 0 | 1 | 1 | 0 | 1 | 1 | X | X | X | X | 1B0000H to 1BFFFFFFH | 0D8000H to 0DFFFFFFH |
| SA35 | 0 | 0 | 1 | 1 | 1 | 0 | 0 | X | X | X | X | 1C0000H to 1CFFFFFFH | 0E0000H to 0E7FFFFH | |

(Continued)

MB84VD2208XEA-90/MB84VD2209XEA-90

(Continued)

| Bank | Sector | Sector Address | | | | | | | | | | Address Range (BYTE mode) | Address Range (WORD mode) |
|--------|--------|----------------|-----|-----|-----|-----|-----|-----|-----|-----|--------------------|------------------------------|------------------------------|
| | | Bank Address | | | | | | | | | | | |
| | | A20 | A19 | A18 | A17 | A16 | A15 | A14 | A13 | A12 | A11 | | |
| Bank 1 | SA36 | 0 | 1 | 1 | 1 | 0 | 1 | X | X | X | X | 1D0000H to 1DFFFFH | 0E8000H to 0EFFFFH |
| | SA37 | 0 | 1 | 1 | 1 | 1 | 0 | X | X | X | X | 1E0000H to 1EFFFFH | 0F0000H to 0F7FFFH |
| | SA38 | 0 | 1 | 1 | 1 | 1 | 1 | X | X | X | X | 1F0000H to 1FFFFFH | 0F8000H to 0FFFFFH |
| Bank 2 | SA39 | 1 | 0 | 0 | 0 | 0 | 0 | X | X | X | X | 200000H to 20FFFFH | 100000H to 107FFFH |
| | SA40 | 1 | 0 | 0 | 0 | 0 | 1 | X | X | X | X | 210000H to 21FFFFH | 108000H to 10FFFFH |
| | SA41 | 1 | 0 | 0 | 0 | 1 | 0 | X | X | X | X | 220000H to 22FFFFH | 110000H to 117FFFH |
| | SA42 | 1 | 0 | 0 | 0 | 1 | 1 | X | X | X | X | 230000H to 23FFFFH | 118000H to 11FFFFH |
| | SA43 | 1 | 0 | 0 | 1 | 0 | 0 | X | X | X | X | 240000H to 24FFFFH | 120000H to 127FFFH |
| | SA44 | 1 | 0 | 0 | 1 | 0 | 1 | X | X | X | X | 250000H to 25FFFFH | 128000H to 12FFFFH |
| | SA45 | 1 | 0 | 0 | 1 | 1 | 0 | X | X | X | X | 260000H to 26FFFFH | 130000H to 137FFFH |
| | SA46 | 1 | 0 | 0 | 1 | 1 | 1 | X | X | X | X | 270000H to 27FFFFH | 138000H to 13FFFFH |
| | SA47 | 1 | 0 | 1 | 0 | 0 | 0 | X | X | X | X | 280000H to 28FFFFH | 140000H to 147FFFH |
| | SA48 | 1 | 0 | 1 | 0 | 0 | 1 | X | X | X | X | 290000H to 29FFFFH | 148000H to 14FFFFH |
| | SA49 | 1 | 0 | 1 | 0 | 1 | 0 | X | X | X | X | 2A0000H to 2AFFFFH | 150000H to 157FFFH |
| | SA50 | 1 | 0 | 1 | 0 | 1 | 1 | X | X | X | X | 2B0000H to 2BFFFFH | 158000H to 15FFFFH |
| | SA51 | 1 | 0 | 1 | 1 | 0 | 0 | X | X | X | X | 2C0000H to 2CFFFFH | 160000H to 167FFFH |
| | SA52 | 1 | 0 | 1 | 1 | 0 | 1 | X | X | X | X | 2D0000H to 2DFFFFH | 168000H to 16FFFFH |
| | SA53 | 1 | 0 | 1 | 1 | 1 | 0 | X | X | X | X | 2E0000H to 2EFFFFH | 170000H to 177FFFH |
| | SA54 | 1 | 0 | 1 | 1 | 1 | 1 | X | X | X | X | 2F0000H to 2FFFFFH | 178000H to 17FFFFH |
| | SA55 | 1 | 1 | 0 | 0 | 0 | 0 | X | X | X | X | 300000H to 30FFFFH | 180000H to 187FFFH |
| | SA56 | 1 | 1 | 0 | 0 | 0 | 1 | X | X | X | X | 310000H to 31FFFFH | 188000H to 18FFFFH |
| | SA57 | 1 | 1 | 0 | 0 | 1 | 0 | X | X | X | X | 320000H to 32FFFFH | 190000H to 197FFFH |
| | SA58 | 1 | 1 | 0 | 0 | 1 | 1 | X | X | X | X | 330000H to 33FFFFH | 198000H to 19FFFFH |
| | SA59 | 1 | 1 | 0 | 1 | 0 | 0 | X | X | X | X | 340000H to 34FFFFH | 1A0000H to 1A7FFFH |
| | SA60 | 1 | 1 | 0 | 1 | 0 | 1 | X | X | X | X | 350000H to 35FFFFH | 1A8000H to 1AFFFFH |
| | SA61 | 1 | 1 | 0 | 1 | 1 | 0 | X | X | X | X | 360000H to 36FFFFH | 1B0000H to 1B7FFFH |
| | SA62 | 1 | 1 | 0 | 1 | 1 | 1 | X | X | X | X | 370000H to 37FFFFH | 1B8000H to 1BFFFFH |
| | SA63 | 1 | 1 | 1 | 0 | 0 | 0 | X | X | X | X | 380000H to 38FFFFH | 1C0000H to 1C7FFFH |
| | SA64 | 1 | 1 | 1 | 0 | 0 | 1 | X | X | X | X | 390000H to 39FFFFH | 1C8000H to 1CFFFFH |
| | SA65 | 1 | 1 | 1 | 0 | 1 | 0 | X | X | X | X | 3A0000H to 3AFFFFH | 1D0000H to 1D7FFFH |
| | SA66 | 1 | 1 | 1 | 0 | 1 | 1 | X | X | X | X | 3B0000H to 3BFFFFH | 1D8000H to 1DFFFFH |
| | SA67 | 1 | 1 | 1 | 1 | 0 | 0 | X | X | X | X | 3C0000H to 3CFFFFH | 1E0000H to 1E7FFFH |
| | SA68 | 1 | 1 | 1 | 1 | 0 | 1 | X | X | X | X | 3D0000H to 3DFFFFH | 1E8000H to 1EFFFFH |
| SA69 | 1 | 1 | 1 | 1 | 1 | 0 | X | X | X | X | 3E0000H to 3EFFFFH | 1F0000H to 1F7FFFH | |
| SA70 | 1 | 1 | 1 | 1 | 1 | 1 | X | X | X | X | 3F0000H to 3FFFFFH | 1F8000H to 1FFFFFH | |

MB84VD2208XEA-90/MB84VD2209XEA-90

**Table 3. 1 Sector Group Addresses (MB84VD2208XEA)
(Top Boot Block)**

| Sector Group | A ₂₀ | A ₁₉ | A ₁₈ | A ₁₇ | A ₁₆ | A ₁₅ | A ₁₄ | A ₁₃ | A ₁₂ | Sectors |
|--------------|-----------------|-----------------|-----------------|-----------------|-----------------|-----------------|-----------------|-----------------|-----------------|--------------|
| SGA0 | 0 | 0 | 0 | 0 | 0 | 0 | X | X | X | SA0 |
| SGA1 | 0 | 0 | 0 | 0 | 0 | 1 | X | X | X | SA1 to SA3 |
| | | | | | 1 | 0 | | | | |
| | | | | | 1 | 1 | | | | |
| SGA2 | 0 | 0 | 0 | 1 | X | X | X | X | X | SA4 to SA7 |
| SGA3 | 0 | 0 | 1 | 0 | X | X | X | X | X | SA8 to SA11 |
| SGA4 | 0 | 0 | 1 | 1 | X | X | X | X | X | SA12 to SA15 |
| SGA5 | 0 | 1 | 0 | 0 | X | X | X | X | X | SA16 to SA19 |
| SGA6 | 0 | 1 | 0 | 1 | X | X | X | X | X | SA20 to SA23 |
| SGA7 | 0 | 1 | 1 | 0 | X | X | X | X | X | SA24 to SA27 |
| SGA8 | 0 | 1 | 1 | 1 | X | X | X | X | X | SA28 to SA31 |
| SGA9 | 1 | 0 | 0 | 0 | X | X | X | X | X | SA32 to SA35 |
| SGA10 | 1 | 0 | 0 | 1 | X | X | X | X | X | SA36 to SA39 |
| SGA11 | 1 | 0 | 1 | 0 | X | X | X | X | X | SA40 to SA43 |
| SGA12 | 1 | 0 | 1 | 1 | X | X | X | X | X | SA44 to SA47 |
| SGA13 | 1 | 1 | 0 | 0 | X | X | X | X | X | SA48 to SA51 |
| SGA14 | 1 | 1 | 0 | 1 | X | X | X | X | X | SA52 to SA55 |
| SGA15 | 1 | 1 | 1 | 0 | X | X | X | X | X | SA56 to SA59 |
| SGA16 | 1 | 1 | 1 | 1 | 0 | 0 | X | X | X | SA60 to SA62 |
| | | | | | 0 | 1 | | | | |
| | | | | | 1 | 0 | | | | |
| SGA17 | 1 | 1 | 1 | 1 | 1 | 1 | 0 | 0 | 0 | SA63 |
| SGA18 | 1 | 1 | 1 | 1 | 1 | 1 | 0 | 0 | 1 | SA64 |
| SGA19 | 1 | 1 | 1 | 1 | 1 | 1 | 0 | 1 | 0 | SA65 |
| SGA20 | 1 | 1 | 1 | 1 | 1 | 1 | 0 | 1 | 1 | SA66 |
| SGA21 | 1 | 1 | 1 | 1 | 1 | 1 | 1 | 0 | 0 | SA67 |
| SGA22 | 1 | 1 | 1 | 1 | 1 | 1 | 1 | 0 | 1 | SA68 |
| SGA23 | 1 | 1 | 1 | 1 | 1 | 1 | 1 | 1 | 0 | SA69 |
| SGA24 | 1 | 1 | 1 | 1 | 1 | 1 | 1 | 1 | 1 | SA70 |

MB84VD2208XEA-90/MB84VD2209XEA-90

**Table 3. 2 Sector Group Addresses (MB84VD2209XEA)
(Bottom Boot Block)**

| Sector Group | A ₂₀ | A ₁₉ | A ₁₈ | A ₁₇ | A ₁₆ | A ₁₅ | A ₁₄ | A ₁₃ | A ₁₂ | Sectors |
|--------------|-----------------|-----------------|-----------------|-----------------|-----------------|-----------------|-----------------|-----------------|-----------------|--------------|
| SGA0 | 0 | 0 | 0 | 0 | 0 | 0 | 0 | 0 | 0 | SA0 |
| SGA1 | 0 | 0 | 0 | 0 | 0 | 0 | 0 | 0 | 1 | SA1 |
| SGA2 | 0 | 0 | 0 | 0 | 0 | 0 | 0 | 1 | 0 | SA2 |
| SGA3 | 0 | 0 | 0 | 0 | 0 | 0 | 0 | 1 | 1 | SA3 |
| SGA4 | 0 | 0 | 0 | 0 | 0 | 0 | 1 | 0 | 0 | SA4 |
| SGA5 | 0 | 0 | 0 | 0 | 0 | 0 | 1 | 0 | 1 | SA5 |
| SGA6 | 0 | 0 | 0 | 0 | 0 | 0 | 1 | 1 | 0 | SA6 |
| SGA7 | 0 | 0 | 0 | 0 | 0 | 0 | 1 | 1 | 1 | SA7 |
| SGA8 | 0 | 0 | 0 | 0 | 0 | 1 | X | X | X | SA8 to SA10 |
| | | | | | 1 | 0 | | | | |
| | | | | | 1 | 1 | | | | |
| SGA9 | 0 | 0 | 0 | 1 | X | X | X | X | X | SA11 to SA14 |
| SGA10 | 0 | 0 | 1 | 0 | X | X | X | X | X | SA15 to SA18 |
| SGA11 | 0 | 0 | 1 | 1 | X | X | X | X | X | SA19 to SA22 |
| SGA12 | 0 | 1 | 0 | 0 | X | X | X | X | X | SA23 to SA26 |
| SGA13 | 0 | 1 | 0 | 1 | X | X | X | X | X | SA27 to SA30 |
| SGA14 | 0 | 1 | 1 | 0 | X | X | X | X | X | SA31 to SA34 |
| SGA15 | 0 | 1 | 1 | 1 | X | X | X | X | X | SA35 to SA38 |
| SGA16 | 1 | 0 | 0 | 0 | X | X | X | X | X | SA39 to SA42 |
| SGA17 | 1 | 0 | 0 | 1 | X | X | X | X | X | SA43 to SA46 |
| SGA18 | 1 | 0 | 1 | 0 | X | X | X | X | X | SA47 to SA50 |
| SGA19 | 1 | 0 | 1 | 1 | X | X | X | X | X | SA51 to SA54 |
| SGA20 | 1 | 1 | 0 | 0 | X | X | X | X | X | SA55 to SA58 |
| SGA21 | 1 | 1 | 0 | 1 | X | X | X | X | X | SA59 to SA62 |
| SGA22 | 1 | 1 | 1 | 0 | X | X | X | X | X | SA63 to SA66 |
| SGA23 | 1 | 1 | 1 | 1 | 0 | 0 | X | X | X | SA67 to SA69 |
| | | | | | 0 | 1 | | | | |
| | | | | | 1 | 0 | | | | |
| SGA24 | 1 | 1 | 1 | 1 | 1 | 1 | X | X | X | SA70 |

MB84VD2208XEA-90/MB84VD2209XEA-90

Table 4 Flash Memory Autoselect Codes

| Type | | A ₁₂ to A ₁₉ | A ₆ | A ₁ | A ₀ | A ₋₁ *1 | Code (HEX) | |
|----------------------|---------------|------------------------------------|-----------------|-----------------|-----------------|--------------------|-----------------|-------|
| Manufacturer's Code | | X | V _{IL} | V _{IL} | V _{IL} | V _{IL} | 04H | |
| Device Code | MB84VD22081EA | Byte | X | V _{IL} | V _{IL} | V _{IH} | V _{IL} | 59H |
| | | Word | | | | | X | 2259H |
| | MB84VD22091EA | Byte | X | V _{IL} | V _{IL} | V _{IH} | V _{IL} | 5AH |
| | | Word | | | | | X | 225AH |
| | MB84VD22082EA | Byte | X | V _{IL} | V _{IL} | V _{IH} | V _{IL} | 55H |
| | | Word | | | | | X | 2255H |
| | MB84VD22092EA | Byte | X | V _{IL} | V _{IL} | V _{IH} | V _{IL} | 56H |
| | | Word | | | | | X | 2256H |
| | MB84VD22083EA | Byte | X | V _{IL} | V _{IL} | V _{IH} | V _{IL} | 50H |
| | | Word | | | | | X | 2250H |
| | MB84VD22093EA | Byte | X | V _{IL} | V _{IL} | V _{IH} | V _{IL} | 53H |
| | | Word | | | | | X | 2253H |
| | MB84VD22084EA | Byte | X | V _{IL} | V _{IL} | V _{IH} | V _{IL} | 5CH |
| | | Word | | | | | X | 225CH |
| | MB84VD22094EA | Byte | X | V _{IL} | V _{IL} | V _{IH} | V _{IL} | 5FH |
| | | Word | | | | | X | 225FH |
| Sector Group protect | | Sector Group Address | V _{IL} | V _{IH} | V _{IL} | V _{IL} | 01H*2 | |

*1: A₋₁ is for Byte mode.

*2: Output 01H at protected sector address and output 00H at unprotected sector address.

MB84VD2208XEA-90/MB84VD2209XEA-90

Table 5 Flash Memory Command Definitions

| Command Sequence | | Bus Write Cycles Req'd | First Bus Write Cycle | | Second Bus Write Cycle | | Third Bus Write Cycle | | Fourth Bus Read/Write Cycle | | Fifth Bus Write Cycle | | Sixth Bus Write Cycle | |
|---|------|------------------------|-----------------------|------|------------------------|-------------|-----------------------|------|-----------------------------|------|-----------------------|------|-----------------------|------|
| | | | Addr. | Data | Addr. | Data | Addr. | Data | Addr. | Data | Addr. | Data | Addr. | Data |
| Read/Reset (Note 1) | | 1 | XXXH | F0H | — | — | — | — | — | — | — | — | — | — |
| Read/Reset (Note 1) | Word | 3 | 555H | AAH | 2AAH | 55H | 555H | F0H | RA | RD | — | — | — | — |
| | Byte | | AAAH | | 555H | | AAAH | | | | | | | |
| Autoselect | Word | 3 | 555H | AAH | 2AAH | 55H | (BA) 555H | 90H | — | — | — | — | — | — |
| | Byte | | AAAH | | 555H | | (BA) AAAH | | | | | | | |
| Program | Word | 4 | 555H | AAH | 2AAH | 55H | 555H | A0H | PA | PD | — | — | — | — |
| | Byte | | AAAH | | 555H | | AAAH | | | | | | | |
| Chip Erase | Word | 6 | 555H | AAH | 2AAH | 55H | 555H | 80H | 555H | AAH | 2AAH | 55H | 555H | 10H |
| | Byte | | AAAH | | 555H | | AAAH | | 555H | | AAAH | | | |
| Sector Erase | Word | 6 | 555H | AAH | 2AAH | 55H | 555H | 80H | 555H | AAH | 2AAH | 55H | SA | 30H |
| | Byte | | AAAH | | 555H | | AAAH | | 555H | | AAAH | | | |
| Sector Erase Suspend | | 1 | BA | B0H | — | — | — | — | — | — | — | — | — | — |
| Sector Erase Resume | | 1 | BA | 30H | — | — | — | — | — | — | — | — | — | — |
| Set to Fast Mode | Word | 3 | 555H | AAH | 2AAH | 55H | 555H | 20H | — | — | — | — | — | — |
| | Byte | | AAAH | | 555H | | AAAH | | | | | | | |
| Fast Program (Note 2) | Word | 2 | XXXH | A0H | PA | PD | — | — | — | — | — | — | — | — |
| | Byte | | — | — | — | — | — | — | — | — | — | — | — | — |
| Reset from Fast Mode (Note 2) | Word | 2 | BA | 90H | XXXH | F0H (Note6) | — | — | — | — | — | — | — | — |
| | Byte | | — | — | — | — | — | — | — | — | — | — | — | — |
| Extended Sector Group Protection (Note 3) | Word | 4 | XXXH | 60H | SPA | 60H | SPA | 40H | SPA | SD | — | — | — | — |
| | Byte | | — | — | — | — | — | — | — | — | — | — | — | — |
| Query (Note 4) | Word | 1 | 55H | 98H | — | — | — | — | — | — | — | — | — | — |
| | Byte | | AAH | | — | — | — | — | — | — | — | — | — | — |
| Hi-ROM Entry | Word | 3 | 555H | AAH | 2AAH | 55H | 555H | 88H | — | — | — | — | — | — |
| | Byte | | AAAH | | 555H | | AAAH | | | | | | | |
| Hi-ROM Program (Note 5) | Word | 4 | 555H | AAH | 2AAH | 55H | 555H | A0H | PA | PD | — | — | — | — |
| | Byte | | AAAH | | 555H | | AAAH | | | | | | | |
| Hi-ROM Erase (Note 5) | Word | 6 | 555H | AAH | 2AAH | 55H | 555H | 80H | 555H | AAH | 2AAH | 55H | HRA | 30H |
| | Byte | | AAAH | | 555H | | AAAH | | 555H | | AAAH | | | |
| Hi-ROM Exit (Note 5) | Word | 4 | 555H | AAH | 2AAH | 55H | (HRBA) 555H | 90H | XXXH | 00H | — | — | — | — |
| | Byte | | AAAH | | 555H | | (HRBA) AAAH | | | | | | | |

Notes:1: Both Read/Reset commands are functionally equivalent, resetting the device to the read mode.
 2: This command is valid while Fast Mode.
 3: This command is valid while RESET=VID.

(Continued)

MB84VD2208XEA-90/MB84VD2209XEA-90

■ ABSOLUTE MAXIMUM RATINGS

| Parameter | Symbol | Rating | | Unit |
|--|-------------------------------------|--------|-----------------------|------|
| | | Min. | Max. | |
| Storage Temperature | T _{stg} | -55 | +125 | °C |
| Ambient Temperature with Power Applied | T _A | -25 | +85 | °C |
| Voltage with Respect to Ground All pins except A ₉ , $\overline{\text{OE}}$, $\overline{\text{RESET}}$, $\overline{\text{WP/ACC}}$ (Note 1) | V _{IN} , V _{OUT} | -0.3 | V _{ccf} +0.4 | V |
| | | | V _{ccs} +0.4 | V |
| V _{ccf} /V _{ccs} Supply (Note 1) | V _{ccf} , V _{ccs} | -0.3 | +4.0 | V |
| A ₉ and $\overline{\text{OE}}$ (Note 2) | V _{IN} | -0.3 | +13.0 | V |
| $\overline{\text{RESET}}$ (Note 2) | V _{IN} | -0.5 | +13.0 | V |
| $\overline{\text{WP/ACC}}$ (Note 3) | V _{IN} | -0.5 | +10.5 | V |

WARNING: Semiconductor devices can be permanently damaged by application of stress (voltage, current, temperature, etc.) in excess of absolute maximum ratings. Do not exceed these ratings.

- Notes:**
1. Minimum DC voltage on input or I/O pins is -0.3 V. During voltage transitions, input or I/O pins may undershoot V_{SS} to -2.0 V for periods of up to 20 ns. Maximum DC voltage on input or I/O pins is V_{ccf} +0.4 V or V_{ccs}+0.4 V. During voltage transitions, input or I/O pins may overshoot to V_{ccf}+2.0 V or V_{ccs}+2.0 V for periods of up to 20 ns.
 2. Minimum DC input voltage on A₉ and $\overline{\text{OE}}$ pin is -0.3 V. Minimum DC input voltage on $\overline{\text{RESET}}$ pin is -0.5 V. During voltage transitions, A₉, $\overline{\text{OE}}$, and $\overline{\text{RESET}}$ pins may undershoot V_{SS} to -2.0 V for periods of up to 20 ns.
Voltage difference between input and supply voltage (V_{IN}-V_{ccf} or V_{ccs}) does not exceed 9.0 V. Maximum DC input voltage on A₉, $\overline{\text{OE}}$, and $\overline{\text{RESET}}$ pins is +13.0 V which may overshoot to 14.0 V for periods of up to 20 ns.
 3. Minimum DC input voltage on $\overline{\text{WP/ACC}}$ pin is -0.5 V. During voltage transitions, $\overline{\text{WP/ACC}}$ pin may undershoot V_{SS} to -2.0 V for periods of up to 20 ns. Maximum DC input voltage on $\overline{\text{WP/ACC}}$ pin is +10.5 V which may overshoot to 12.0 V for periods of up to 20 ns, when V_{ccf} is applied.

■ RECOMMENDED OPERATING RANGES

| Parameter | Symbol | Value | | Unit |
|--|-------------------------------------|-------|------|------|
| | | Min. | Max. | |
| Ambient Temperature | T _a | -25 | +85 | °C |
| V _{ccf} /V _{ccs} Supply Voltages | V _{ccf} , V _{ccs} | +2.7 | +3.3 | V |

Note: Operating ranges define those limits between which the functionality of the device is guaranteed.

WARNING: The recommended operating conditions are required in order to ensure the normal operation of the semiconductor device. All of the device's electrical characteristics are warranted when the device is operated within these ranges.

Always use semiconductor devices within their recommended operating condition ranges. Operation outside these ranges may adversely affect reliability and could result in device failure.

No warranty is made with respect to uses, operating conditions, or combinations not represented on the data sheet. Users considering application outside the listed conditions are advised to contact their FUJITSU representatives beforehand.

MB84VD2208XEA-90/MB84VD2209XEA-90

■ ELECTRICAL CHARACTERISTICS

1.DC Characteristics

| Parameter Symbol | Parameter Description | Test Conditions | Min. | Typ. | Max. | Unit | | |
|-------------------|---|---|-----------------------------|------|------|------|----|----|
| I _{LI} | Input Leakage Current | V _{IN} = V _{SS} to V _{CCf} , V _{CCS} | -1.0 | — | +1.0 | μA | | |
| I _{LO} | Output Leakage Current | V _{OUT} = V _{SS} to V _{CCf} , V _{CCS} | -1.0 | — | +1.0 | μA | | |
| I _{LIT} | $\overline{\text{RESET}}$ Inputs Leakage Current | V _{CCf} = V _{CCf} Max., V _{CCS} = V _{CCS} Max., $\overline{\text{RESET}}$ = 12.5V | — | — | 35 | μA | | |
| I _{LIA} | ACC Input Leakage Current | V _{CCf} = V _{CCf} Max., V _{CCS} = V _{CCS} Max., $\overline{\text{WP/ACC}}$ = V _{ACC} Max. | — | — | 20 | mA | | |
| I _{CC1f} | Flash V _{CC} Active Current (Read) (Note 1) | $\overline{\text{CE}}_f = V_{IL}$, $\overline{\text{OE}} = V_{IH}$ | t _{CYCLE} = 5 MHz | Byte | — | — | 16 | mA |
| | | | t _{CYCLE} = 5 MHz | Word | — | — | 18 | |
| | | | t _{CYCLE} = 1 MHz | Byte | — | — | 7 | mA |
| | | | t _{CYCLE} = 1 MHz | Word | — | — | 7 | |
| I _{CC2f} | Flash V _{CC} Active Current (Program/Erase) (Note 2) | $\overline{\text{CE}}_f = V_{IL}$, $\overline{\text{OE}} = V_{IH}$ | — | — | 35 | mA | | |
| I _{CC3f} | Flash V _{CC} Active Current (Read-While-Program) (Note 5) | $\overline{\text{CE}}_f = V_{IL}$, $\overline{\text{OE}} = V_{IH}$ | Byte | — | — | 51 | mA | |
| | | | Word | — | — | 53 | | |
| I _{CC4f} | Flash V _{CC} Active Current (Read-While-Erase) (Note 5) | $\overline{\text{CE}}_f = V_{IL}$, $\overline{\text{OE}} = V_{IH}$ | Byte | — | — | 51 | mA | |
| | | | Word | — | — | 53 | | |
| I _{CC5f} | Flash V _{CC} Active Current (Erase-Suspend-Program) | $\overline{\text{CE}}_f = V_{IL}$, $\overline{\text{OE}} = V_{IH}$ | — | — | 35 | mA | | |
| I _{CC1S} | SRAM V _{CC} Active Current | V _{CCS} = V _{CC} Max., $\overline{\text{CE}}_{1s} = V_{IL}$, $\overline{\text{CE}}_{2s} = V_{IH}$ | t _{CYCLE} = 10 MHz | — | — | 40 | mA | |
| I _{CC2S} | SRAM V _{CC} Active Current | $\overline{\text{CE}}_{1s} = 0.2\text{ V}$, $\overline{\text{CE}}_{2s} = V_{CCS} - 0.2\text{ V}$ | t _{CYCLE} = 10 MHz | — | — | 40 | mA | |
| | | | t _{CYCLE} = 1 MHz | — | — | 8 | mA | |
| I _{SB1f} | Flash V _{CC} Standby Current | V _{CCf} = V _{CC} Max., $\overline{\text{CE}}_f = V_{CCf} \pm 0.3\text{ V}$ $\overline{\text{RESET}} = V_{CCf} \pm 0.3\text{ V}$, $\overline{\text{WP/ACC}} = V_{CCf} \pm 0.3\text{ V}$ | — | 1 | 5 | μA | | |
| I _{SB2f} | Flash V _{CC} Standby Current ($\overline{\text{RESET}}$) | V _{CCf} = V _{CC} Max., $\overline{\text{RESET}} = V_{SS} \pm 0.3\text{ V}$, $\overline{\text{WP/ACC}} = V_{CCf} \pm 0.3\text{ V}$ | — | 1 | 5 | μA | | |
| I _{SB3f} | Flash V _{CC} Current (Automatic Sleep Mode) (Note 3) | V _{CCf} = V _{CC} Max., $\overline{\text{CE}}_f = V_{SS} \pm 0.3\text{ V}$ $\overline{\text{RESET}} = V_{CCf} \pm 0.3\text{ V}$, $\overline{\text{WP/ACC}} = V_{CCf} \pm 0.3\text{ V}$ V _{IN} = V _{CCf} ± 0.3 V or V _{SS} ± 0.3 V | — | 1 | 5 | μA | | |
| I _{SB5} | SRAM V _{CC} Standby Current | 1) $\overline{\text{CE}}_{1s} = V_{IH}$, $\overline{\text{CE}}_{2s} = V_{IH}$ 2) $\overline{\text{CE}}_{2s} = V_{IL}$ | — | — | 0.6 | mA | | |

(Continued)

MB84VD2208XEA-90/MB84VD2209XEA-90

(Continued)

| Parameter Symbol | Parameter Description | Test Conditions | Min. | Typ. | Max. | Unit |
|-------------------|--|---|------|------|-----------------------|------|
| I _{SB1S} | SRAM V _{CC} Standby Current | $\overline{CE1}s \geq V_{CCS} - 0.2V, CE2s \geq V_{CCS} - 0.2V$ | — | 0.2 | 7 | μA |
| I _{SB2S} | SRAM V _{CC} Standby Current | $CE2s \leq 0.2V$ | — | 0.2 | 7 | μA |
| V _{IL} | Input Low Level | — | -0.3 | — | 0.5 | V |
| V _{IH} | Input High Level | — | 2.4 | — | V _{CC} +0.3* | V |
| V _{ID} | Voltage for Sector Protection, and Temporary Sector Unprotection (\overline{RESET}) (Note 4) | — | 11.5 | — | 12.5 | V |
| V _{ACC} | Voltage for Program Acceleration ($\overline{WP/ACC}$) (Note4) | — | 8.5 | 9.0 | 9.5 | V |
| V _{OL} | Output Low Voltage Level | V _{CCF} = V _{CCF} Min., V _{CCS} = V _{CCS} Min., I _{OL} =1.0mA | — | — | 0.4 | V |
| V _{OH} | Output High Voltage Level | V _{CCF} = V _{CCF} Min., V _{CCS} = V _{CCS} Min., I _{OH} =-0.5mA | 2.4 | — | — | V |
| V _{LKO} | Flash Low V _{CCF} Lock-Out Voltage | — | 2.3 | — | 2.5 | V |

* : V_{CC} indicates lower of V_{CCF} or V_{CCS}

- Notes: 1. The I_{CC} current listed includes both the DC operating current and the frequency dependent component.
 2. I_{CC} active while Embedded Algorithm (program or erase) is in progress.
 3. Automatic sleep mode enables the low power mode when address remain stable for 150 ns.
 4. Applicable for only V_{CCF} applying.
 5. Embedded Algorithm (program or erase) is in progress. (@5MHz)

MB84VD2208XEA-90/MB84VD2209XEA-90

2. AC Characteristics

• $\overline{\text{CE}}$ Timing

| Parameter Symbols | | Description | Test Setup | | -90 | Unit |
|-------------------|------------------|-------------------------------------|------------|------|-----|------|
| JEDEC | Standard | | | | | |
| — | t _{CCR} | $\overline{\text{CE}}$ Recover Time | — | Min. | 0 | ns |

• Timing Diagram for alternating SRAM to Flash

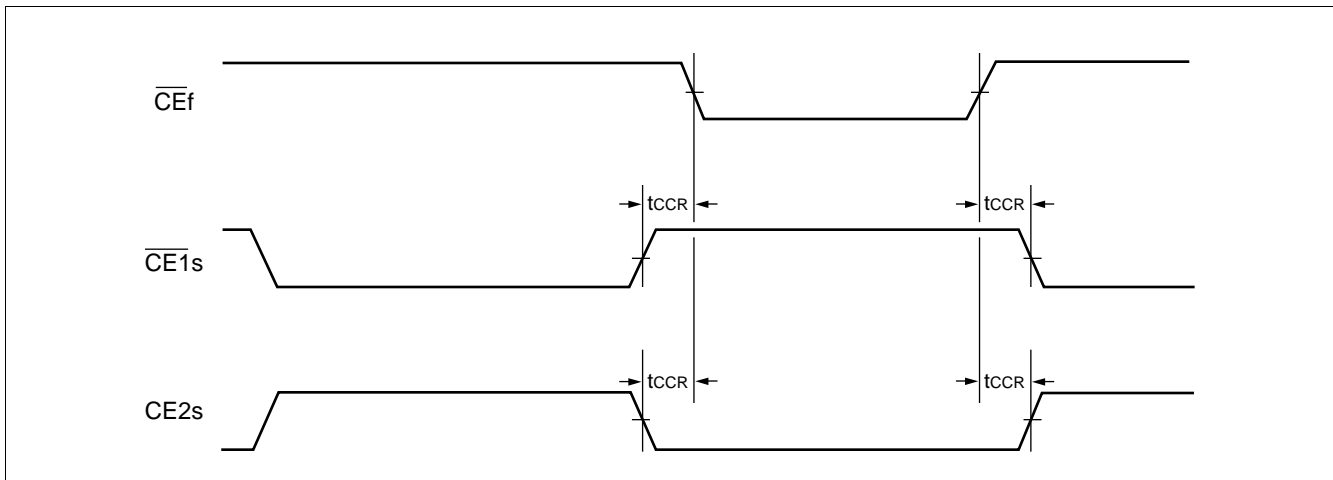

• Read Only Operations Characteristics (Flash)

| Parameter Symbols | | Description | Test Setup | -90 (Note) | | Unit |
|-------------------|--------------------|--|--|------------|------|------|
| JEDEC | Standard | | | Min. | Max. | |
| t _{AVAV} | t _{RC} | Read Cycle Time | — | 90 | — | ns |
| t _{AVQV} | t _{ACC} | Address to Output Delay | $\overline{\text{CE}}_f = V_{IL}$ $\overline{\text{OE}} = V_{IL}$ | — | 90 | ns |
| t _{ELQV} | t _{CEf} | Chip Enable to Output Delay | $\overline{\text{OE}} = V_{IL}$ | — | 90 | ns |
| t _{GLQV} | t _{OE} | Output Enable to Output Delay | — | — | 40 | ns |
| t _{EHQZ} | t _{DF} | Chip Enable to Output High-Z | — | — | 30 | ns |
| t _{GHQZ} | t _{DF} | Output Enable to Output High-Z | — | — | 30 | ns |
| t _{AXQX} | t _{OH} | Output Hold Time From Addresses, $\overline{\text{CE}}_f$ or $\overline{\text{OE}}$, Whichever Occurs First | — | 0 | — | ns |
| — | t _{READY} | $\overline{\text{RESET}}$ Pin Low to Read Mode | — | — | 20 | μs |

Note: Test Conditions—Output Load: 1 TTL gate and 30 pF
 Input rise and fall times: 5 ns
 Input pulse levels: 0.0 V to 3.0 V
 Timing measurement reference level
 Input: 1.5 V
 Output: 1.5 V

MB84VD2208XE-90/MB84VD2209XE-90

• Read Cycle (Flash)

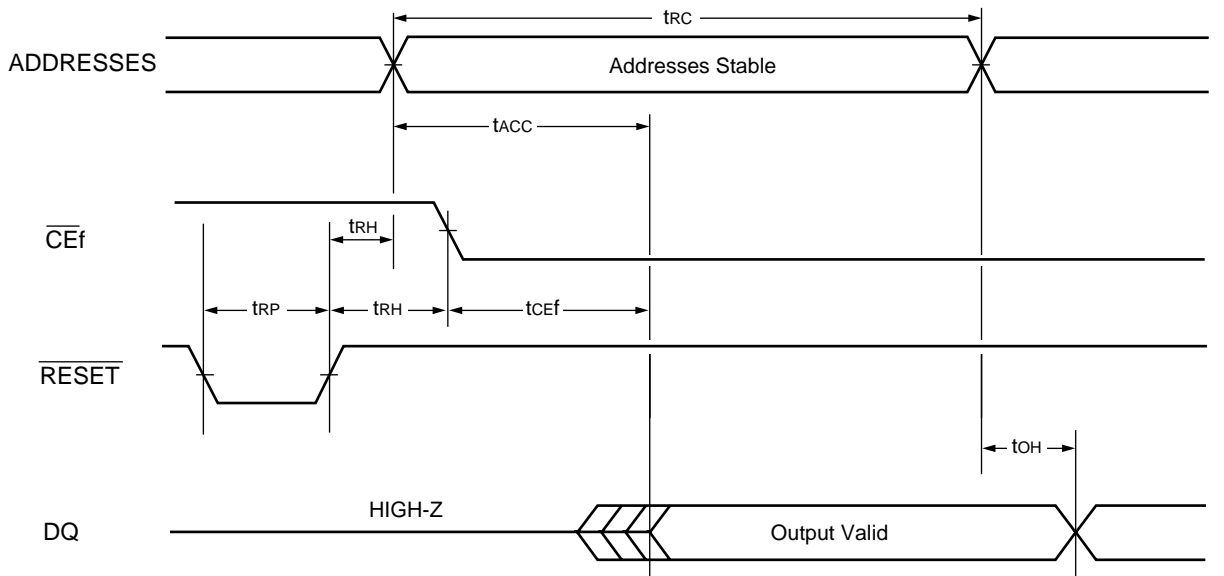
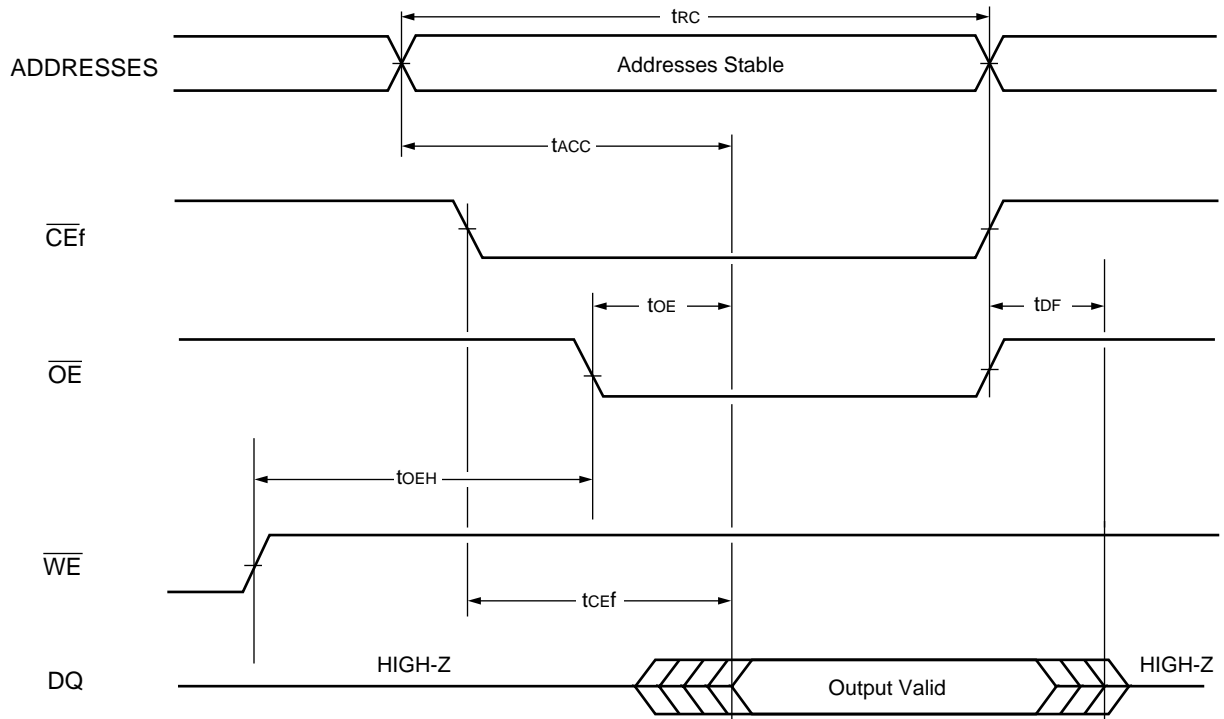

MB84VD2208XEA-90/MB84VD2209XEA-90

• Erase/Program Operations (Flash)

| Parameter Symbols | | Description | -90 | | | Unit |
|--------------------|--------------------|--|------|------|------|------|
| JEDEC | Standard | | Min. | Typ. | Max. | |
| t _{AVAV} | t _{WC} | Write Cycle Time | 90 | — | — | ns |
| t _{AVWL} | t _{AS} | Address Setup Time (\overline{WE} to Addr.) | 0 | — | — | ns |
| — | t _{ASO} | Address Setup Time to \overline{CE} Low During Toggle Bit Polling | 15 | — | — | ns |
| t _{WLAX} | t _{AH} | Address Hold Time (\overline{WE} to Addr.) | 45 | — | — | ns |
| — | t _{AHT} | Address Hold Time from \overline{CE} or \overline{OE} High During Toggle Bit Polling | 0 | — | — | ns |
| t _{DVWH} | t _{DS} | Data Setup Time | 35 | — | — | ns |
| t _{WHDX} | t _{DH} | Data Hold Time | 0 | — | — | ns |
| — | t _{OES} | Output Enable Setup Time | 0 | — | — | ns |
| — | t _{OEH} | Output Enable Hold Time | 0 | — | — | ns |
| | | Read Toggle and Data Polling | 10 | — | — | ns |
| — | t _{CEPH} | \overline{CE} High During Toggle Bit Polling | 20 | — | — | ns |
| — | t _{OEPH} | \overline{OE} High During Toggle Bit Polling | 20 | — | — | ns |
| t _{GHEL} | t _{GHEL} | Read Recover Time Before Write (\overline{OE} to \overline{CEf}) | 0 | — | — | ns |
| t _{GHWL} | t _{GHWL} | Read Recover Time Before Write (\overline{OE} to \overline{WE}) | 0 | — | — | ns |
| t _{WLEL} | t _{WS} | \overline{WE} Setup Time (\overline{CEf} to \overline{WE}) | 0 | — | — | ns |
| t _{ELWL} | t _{CS} | \overline{CEf} Setup Time (\overline{WE} to \overline{CEf}) | 0 | — | — | ns |
| t _{EHWH} | t _{WH} | \overline{WE} Hold Time (\overline{CEf} to \overline{WE}) | 0 | — | — | ns |
| t _{WHEH} | t _{CH} | \overline{CEf} Hold Time (\overline{WE} to \overline{CEf}) | 0 | — | — | ns |
| t _{WLWH} | t _{WP} | Write Pulse Width | 35 | — | — | ns |
| t _{ELEH} | t _{CP} | \overline{CEf} Pulse Width | 35 | — | — | ns |
| t _{WHWL} | t _{WPH} | Write Pulse Width High | 30 | — | — | ns |
| t _{EHEL} | t _{CPH} | \overline{CEf} Pulse Width High | 30 | — | — | ns |
| t _{WHWH1} | t _{WHWH1} | Byte Programming Operation | — | 8 | — | μs |
| | | Word Programming Operation | — | 16 | — | μs |
| t _{WHWH2} | t _{WHWH2} | Sector Erase Operation (Note 1) | — | 1 | — | s |
| — | t _{VCS} | V _{CCf} Setup Time | 50 | — | — | μs |
| — | t _{VLHT} | Voltage Transition Time (Note 2) | 4 | — | — | μs |
| — | t _{VIDR} | Rise Time to V _{ID} (Note 2) | 500 | — | — | ns |
| — | t _{VACCR} | Rise Time to V _{ACC} | 500 | — | — | ns |
| — | t _{RB} | Recover Time from RY/ \overline{BY} | 0 | — | — | ns |

(Continued)

MB84VD2208XEA-90/MB84VD2209XEA-90

(Continued)

| Parameter Symbols | | Description | -90 | | | Unit |
|-------------------|-------------------|---|------|------|------|------|
| JEDEC | Standard | | Min. | Typ. | Max. | |
| — | t _{RP} | $\overline{\text{RESET}}$ Pulse Width | 500 | — | — | ns |
| — | t _{EOE} | Delay Time from Embedded Output Enable | — | — | 90 | ns |
| — | t _{RH} | $\overline{\text{RESET}}$ High Level Period Before Read | 200 | — | — | ns |
| — | t _{BUSY} | Program/Erase Valid to RY/ $\overline{\text{BY}}$ Delay | — | — | 90 | ns |
| — | t _{TOW} | Erase Time-out Time (Note 3) | 50 | — | — | μs |
| — | t _{SPD} | Erase Suspend Transition Time (Note 4) | — | — | 20 | μs |

- Notes:
1. This does not include the preprogramming time.
 2. This timing is for Sector Protection Operation.
 3. The time between writes must be less than "t_{TOW}" otherwise that command will not be accepted and erasure will start. A time-out or "t_{TOW}" from the rising edge of last $\overline{\text{CE}}$ or $\overline{\text{WE}}$ whichever happens first will initiate the execution of the Sector Erase command(s).
 4. When the Erase Suspend command is written during the Sector Erase operation, the device will take a maximum of "t_{SPD}" to suspend the erase operation.

MB84VD2208XEA-90/MB84VD2209XEA-90

• Write Cycle (\overline{WE} control) (Flash)

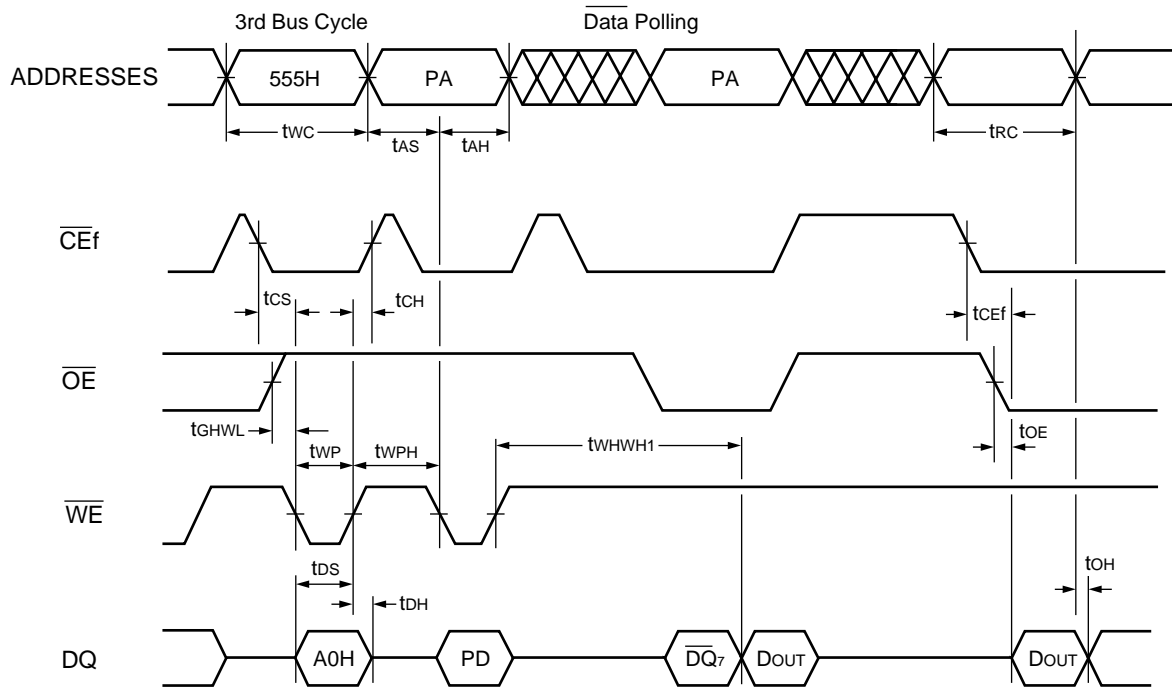

- Notes:
1. PA is address of the memory location to be programmed.
 2. PD is data to be programmed at byte address.
 3. \overline{DQ}_7 is the output of the complement of the data written to the device.
 4. D_{OUT} is the output of the data written to the device.
 5. Figure indicates last two bus cycles out of four bus cycle sequence.
 6. These waveforms are for the x16 mode. (The addresses differ from x8 mode.)

MB84VD2208XEA-90/MB84VD2209XEA-90

• Write Cycle ($\overline{\text{CEf}}$ control) (Flash)

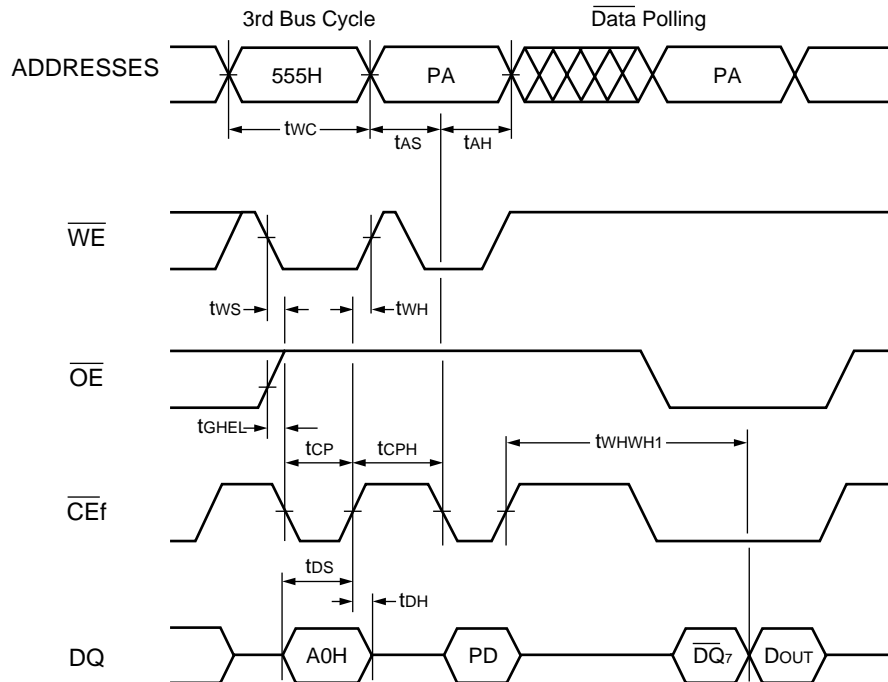

- Notes:
1. PA is address of the memory location to be programmed.
 2. PD is data to be programmed at byte address.
 3. $\overline{\text{DQ}}_7$ is the output of the complement of the data written to the device.
 4. D_{OUT} is the output of the data written to the device.
 5. Figure indicates last two bus cycles out of four bus cycle sequence.
 6. These waveforms are for the $\times 16$ mode. (The addresses differ from $\times 8$ mode.)

MB84VD2208XEA-90/MB84VD2209XEA-90

• AC Waveforms Chip/Sector Erase Operations (Flash)

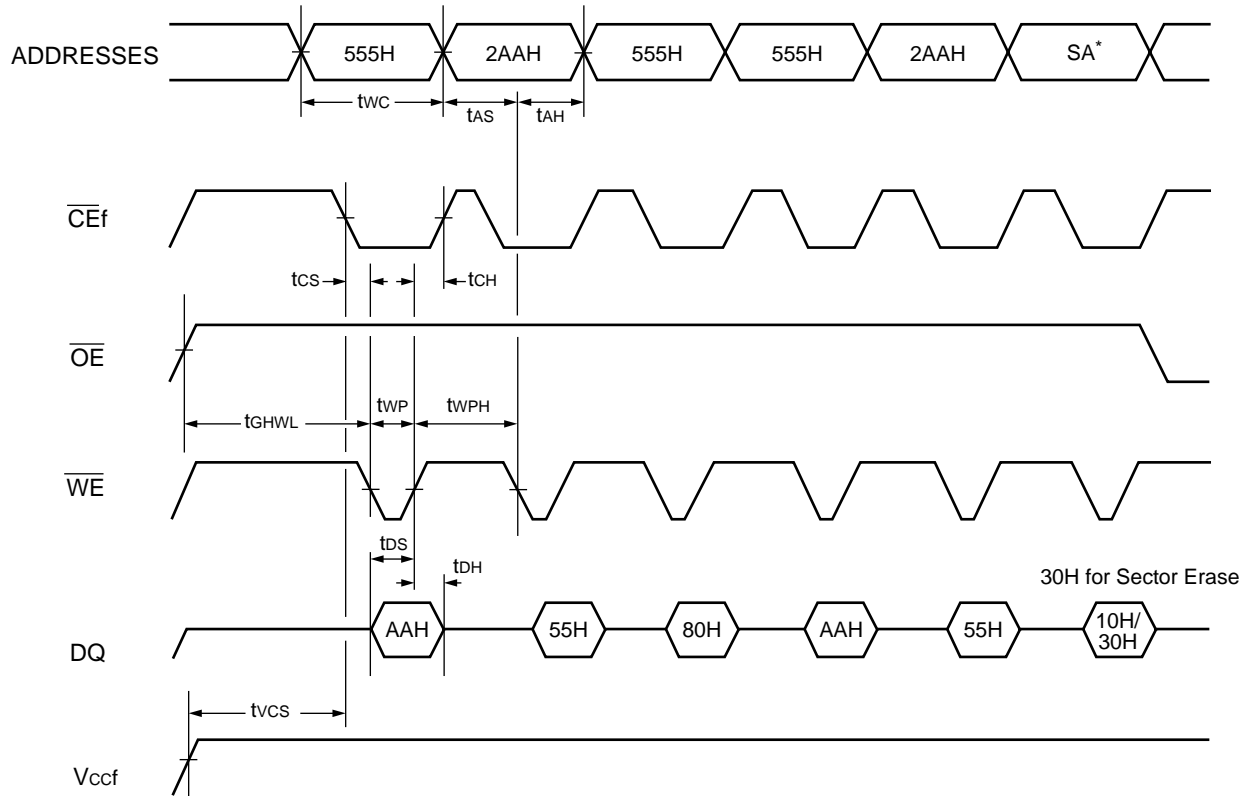

*: SA is the sector address for Sector Erase. Addresses = 555H for Chip Erase.

Note: These waveform are for the x16 mode. (The addresses differ from x8 mode.)

MB84VD2208XEA-90/MB84VD2209XEA-90

• AC Waveforms for $\overline{\text{Data}}$ Polling during Embedded Algorithm Operations (Flash)

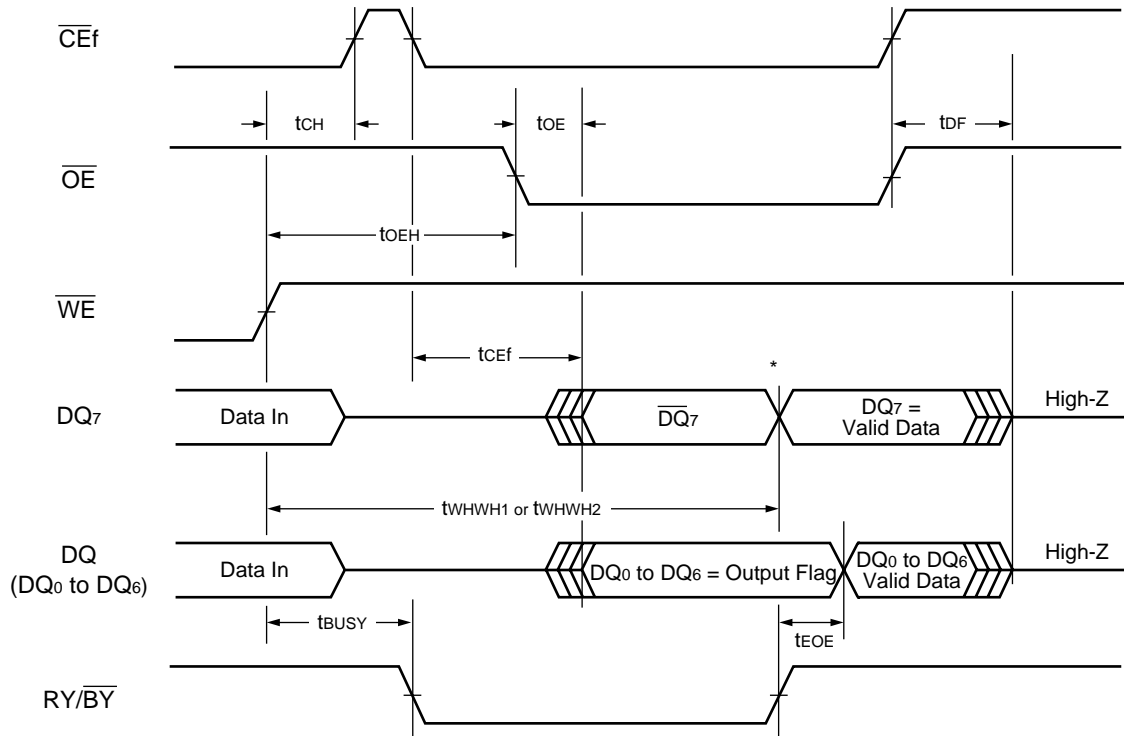

* : $\text{DQ}_7 = \text{Valid Data}$ (The device has completed the Embedded operation.)

MB84VD2208XEA-90/MB84VD2209XEA-90

• AC Waveforms for Toggle Bit during Embedded Algorithm Operations (Flash)

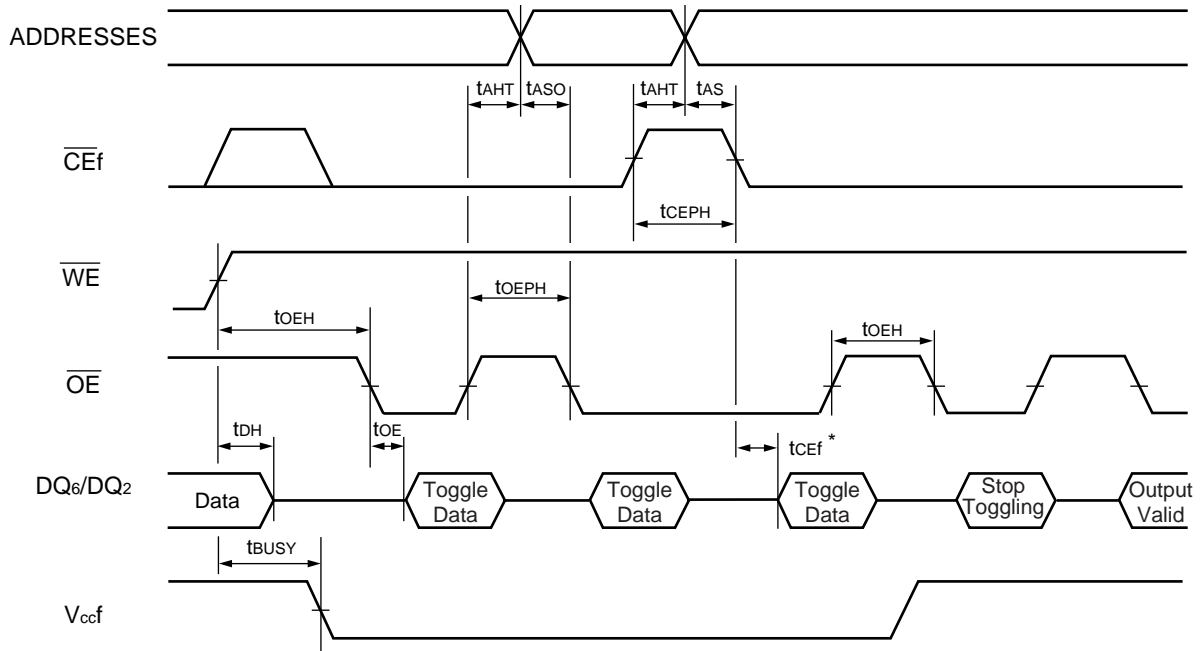

* : DQ₆ stops toggling (The device has completed the Embedded operation).

MB84VD2208XEA-90/MB84VD2209XEA-90

• Back-to-back Read/Write Timing Diagram (Flash)

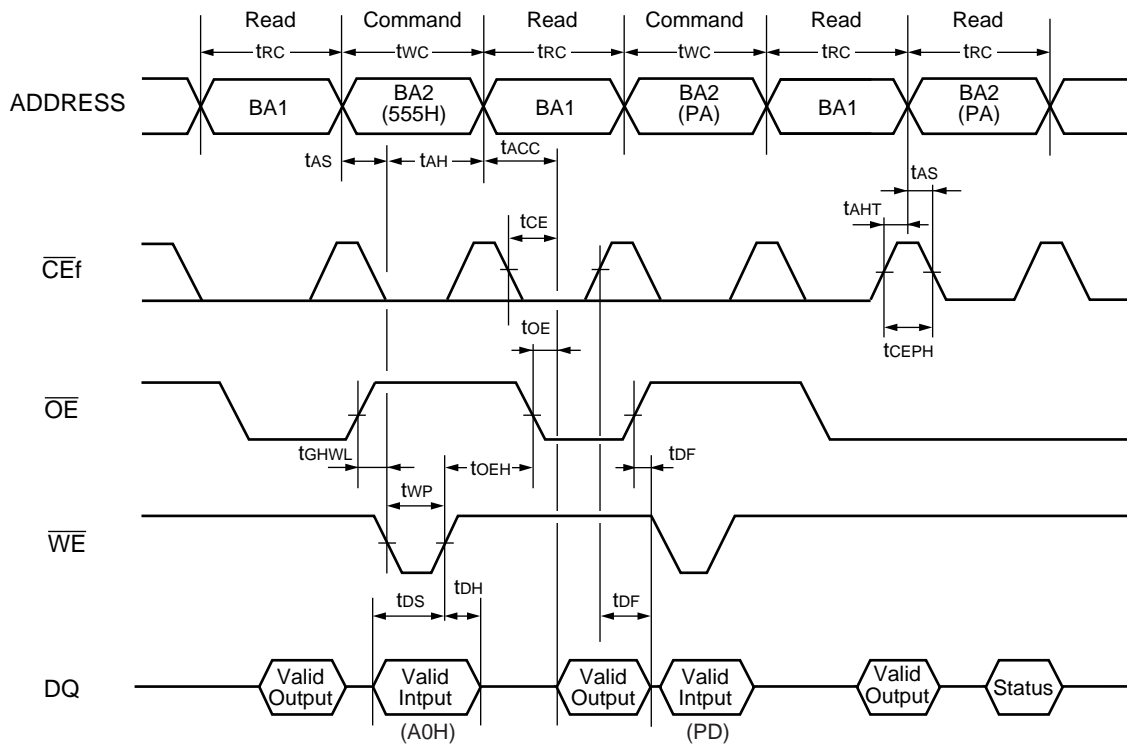

Note: This is example of Read for Bank 1 and Embedded Algorithm (program) for Bank 2.
 BA1: Address of Bank 1.
 BA2: Address of Bank 2.

MB84VD2208XEA-90/MB84VD2209XEA-90

- RY/BY Timing Diagram during Write/Erase Operations (Flash)

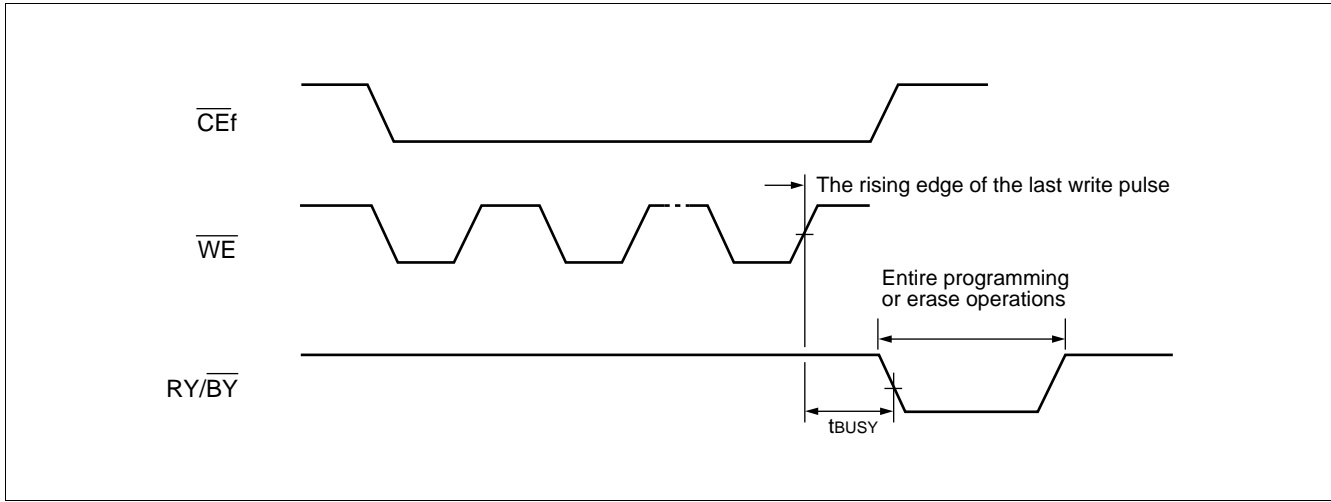

- \overline{RESET} , $\overline{RY/BY}$ Timing Diagram (Flash)

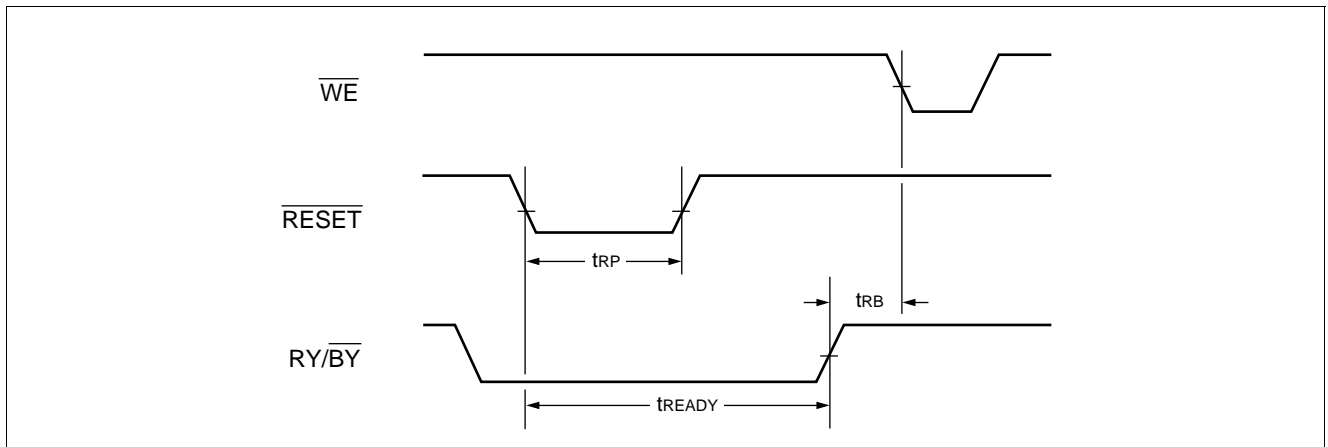

• Temporary Sector Unprotection (Flash)

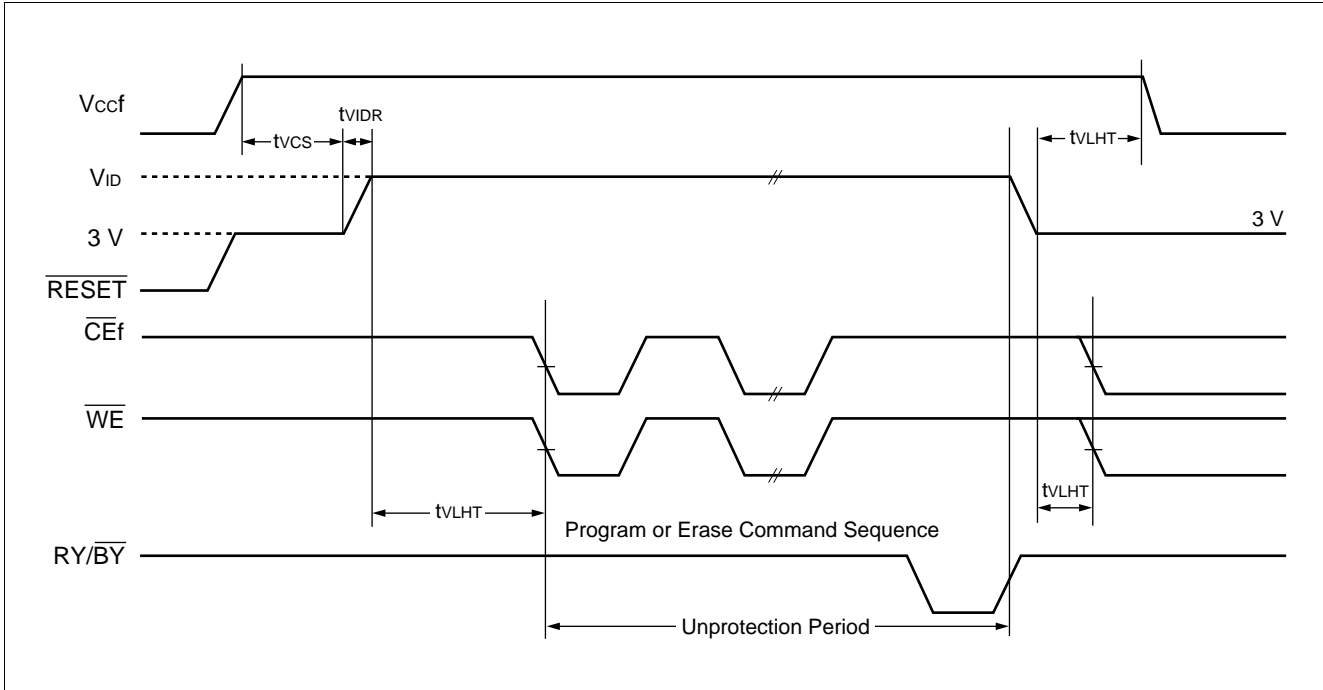

MB84VD2208XEA-90/MB84VD2209XEA-90

• Extended Sector Protection (Flash)

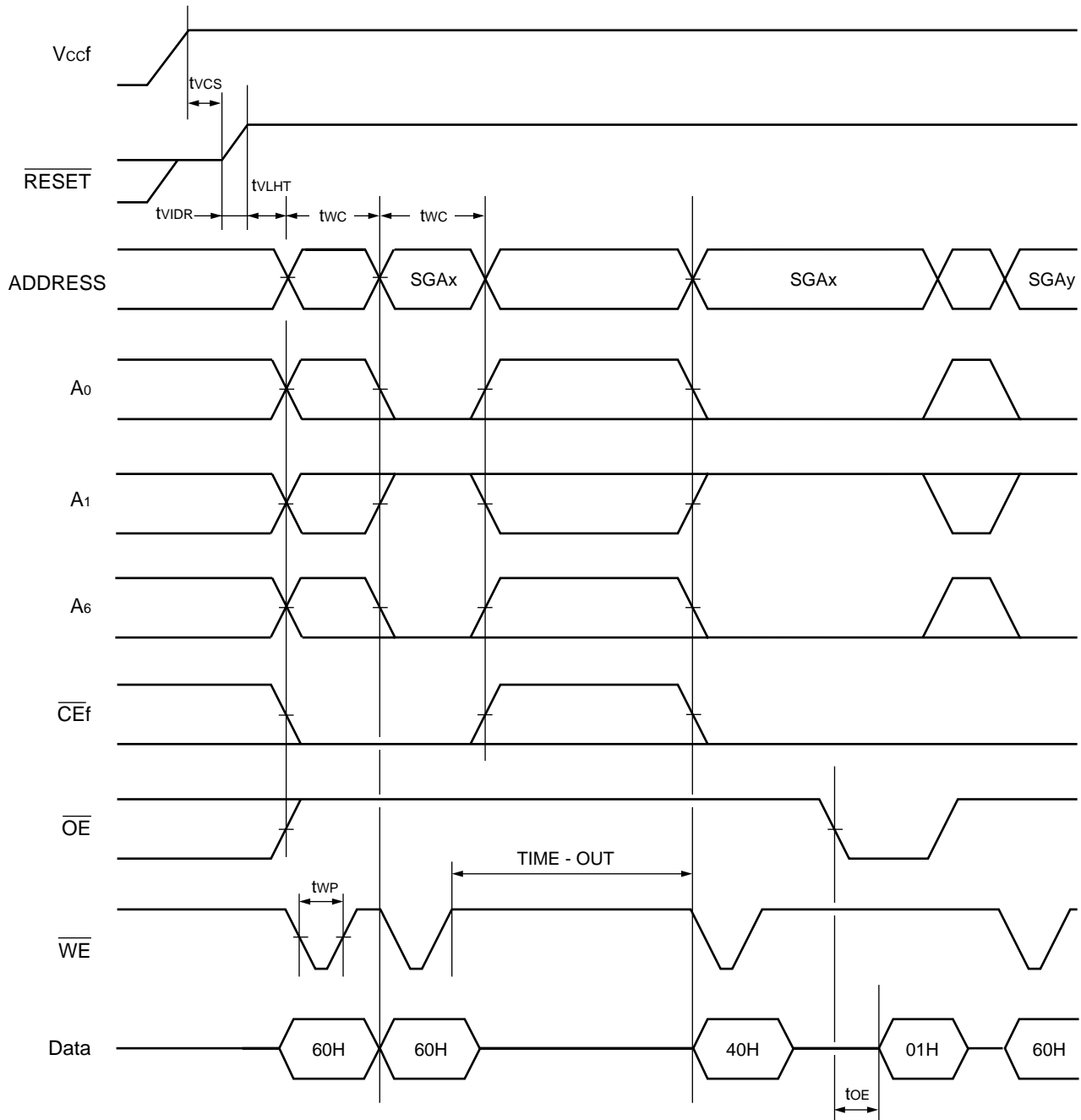

SGAx : Sector Group Address to be protected
 SGAy : Next Group Sector Address to be protected
 TIME-OUT : Time-Out window = 250 μ s (min)

• Accelerated Program (Flash)

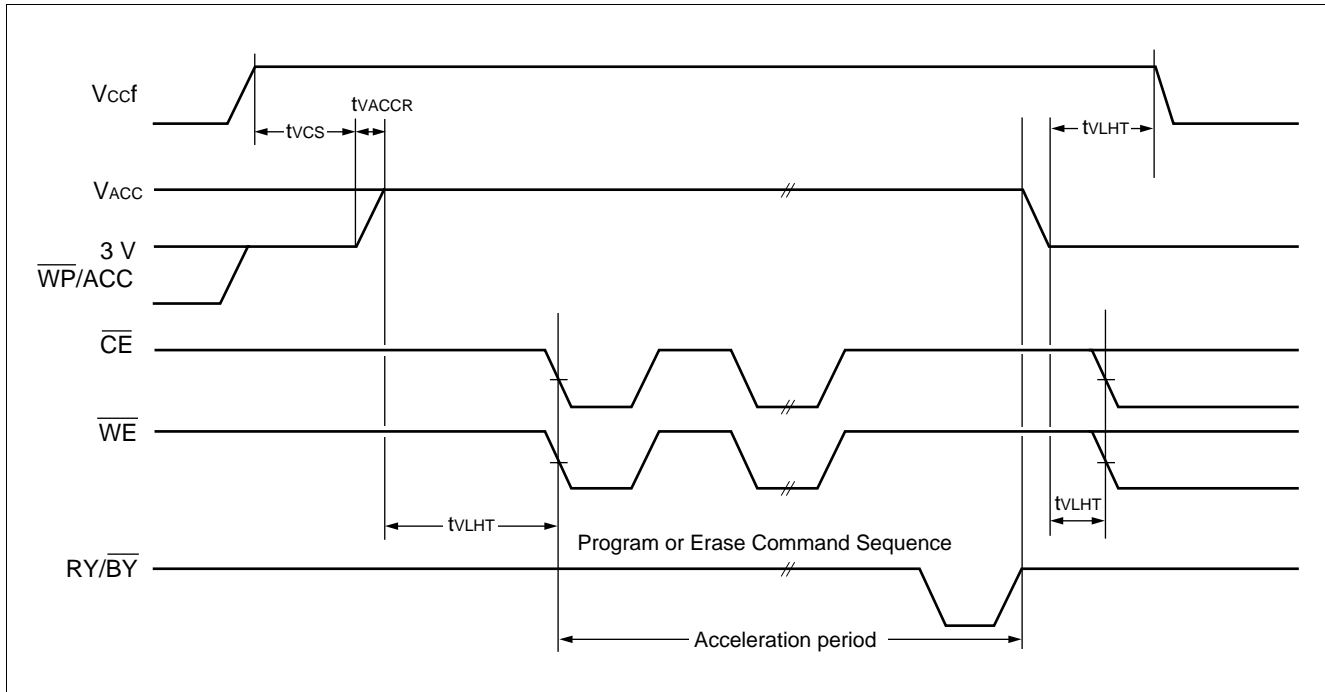

MB84VD2208XEA-90/MB84VD2209XEA-90

- Read Cycle (SRAM)

| Parameter Symbol | Parameter Description | Min. | Max. | Unit |
|------------------|---|------|------|------|
| t _{RC} | Read Cycle Time | 85 | — | ns |
| t _{AA} | Address Access Time | — | 85 | ns |
| t _{CO1} | Chip Enable ($\overline{CE1s}$) Access Time | — | 85 | ns |
| t _{CO2} | Chip Enable (CE2s) Access Time | — | 85 | ns |
| t _{OE} | Output Enable Access Time | — | 45 | ns |
| t _{BA} | \overline{LBs} , \overline{UBs} to Output Valid | — | 85 | ns |
| t _{COE} | Chip Enable ($\overline{CE1s}$ Low and CE2s High) to Output Active | 5 | — | ns |
| t _{OOE} | Output Enable Low to Output Active | 0 | — | ns |
| t _{BE} | \overline{UBs} , \overline{LBs} Enable Low to Output Active | 0 | — | ns |
| t _{OD} | Chip Enable ($\overline{CE1s}$ High or CE2s Low) to Output High-Z | — | 35 | ns |
| t _{ODO} | Output Enable High to Output High-Z | — | 35 | ns |
| t _{BD} | \overline{UBs} , \overline{LBs} Output Enable to Output High-Z | — | 35 | ns |
| t _{OH} | Output Data Hold Time | 10 | — | ns |

MB84VD2208XEA-90/MB84VD2209XEA-90

• Read Cycle (SRAM)

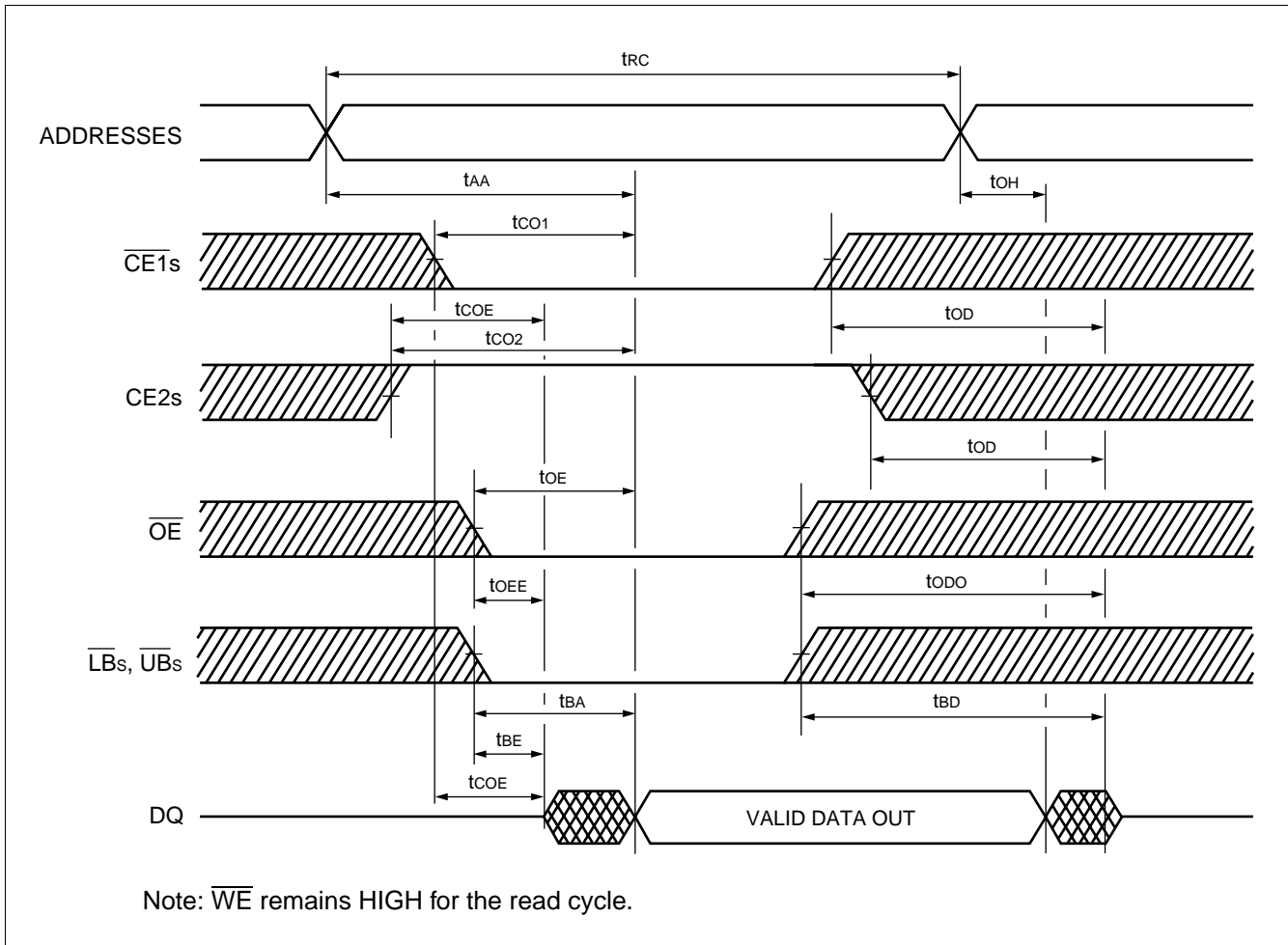

MB84VD2208XEA-90/MB84VD2209XEA-90

• Write Cycle (SRAM)

| Parameter Symbol | Parameter Description | Min. | Max. | Unit |
|------------------|--|------|------|------|
| t _{WC} | Write Cycle Time | 85 | — | ns |
| t _{WP} | Write Pulse Width | 55 | — | ns |
| t _{CW} | Chip Enable to End of Write | 70 | — | ns |
| t _{AW} | Address valid to End of Write | 70 | — | ns |
| t _{BW} | \overline{UB} s, \overline{LB} s to End of Write | 55 | — | ns |
| t _{AS} | Address Setup Time | 0 | — | ns |
| t _{WR} | Write Recovery Time | 0 | — | ns |
| t _{ODW} | \overline{WE} Low to Output High-Z | — | 35 | ns |
| t _{OEW} | \overline{WE} High to Output Active | 0 | — | ns |
| t _{DS} | Data Setup Time | 35 | — | ns |
| t _{DH} | Data Hold Time | 0 | — | ns |

MB84VD2208XEA-90/MB84VD2209XEA-90

• Write Cycle (Note 3) (\overline{WE} control) (SRAM)

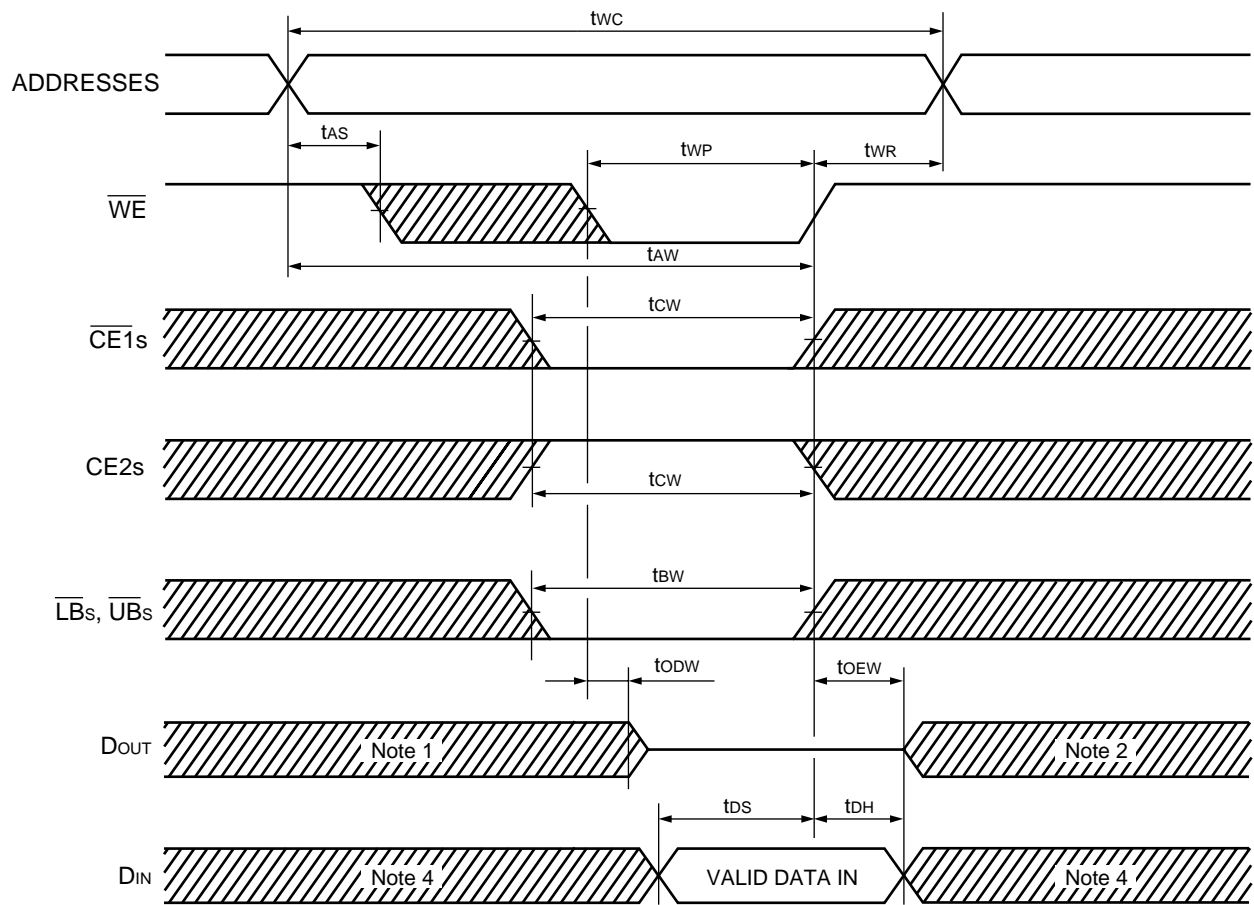

- Notes:
1. If $\overline{CE1s}$ goes LOW (or $\overline{CE2s}$ goes HIGH) coincident with or after \overline{WE} goes LOW, the output will remain at high impedance.
 2. If $\overline{CE1s}$ goes HIGH (or $\overline{CE2s}$ goes LOW) coincident with or before \overline{WE} goes HIGH, the output will remain at high impedance.
 3. If \overline{OE} is HIGH during the write cycle, the outputs will remain at high impedance.
 4. Because I/O signals may be in the output state at this time, input signals of reverse polarity must not be applied.

MB84VD2208XEA-90/MB84VD2209XEA-90

• Write Cycle (Note 1) ($\overline{CE1s}$ control) (SRAM)

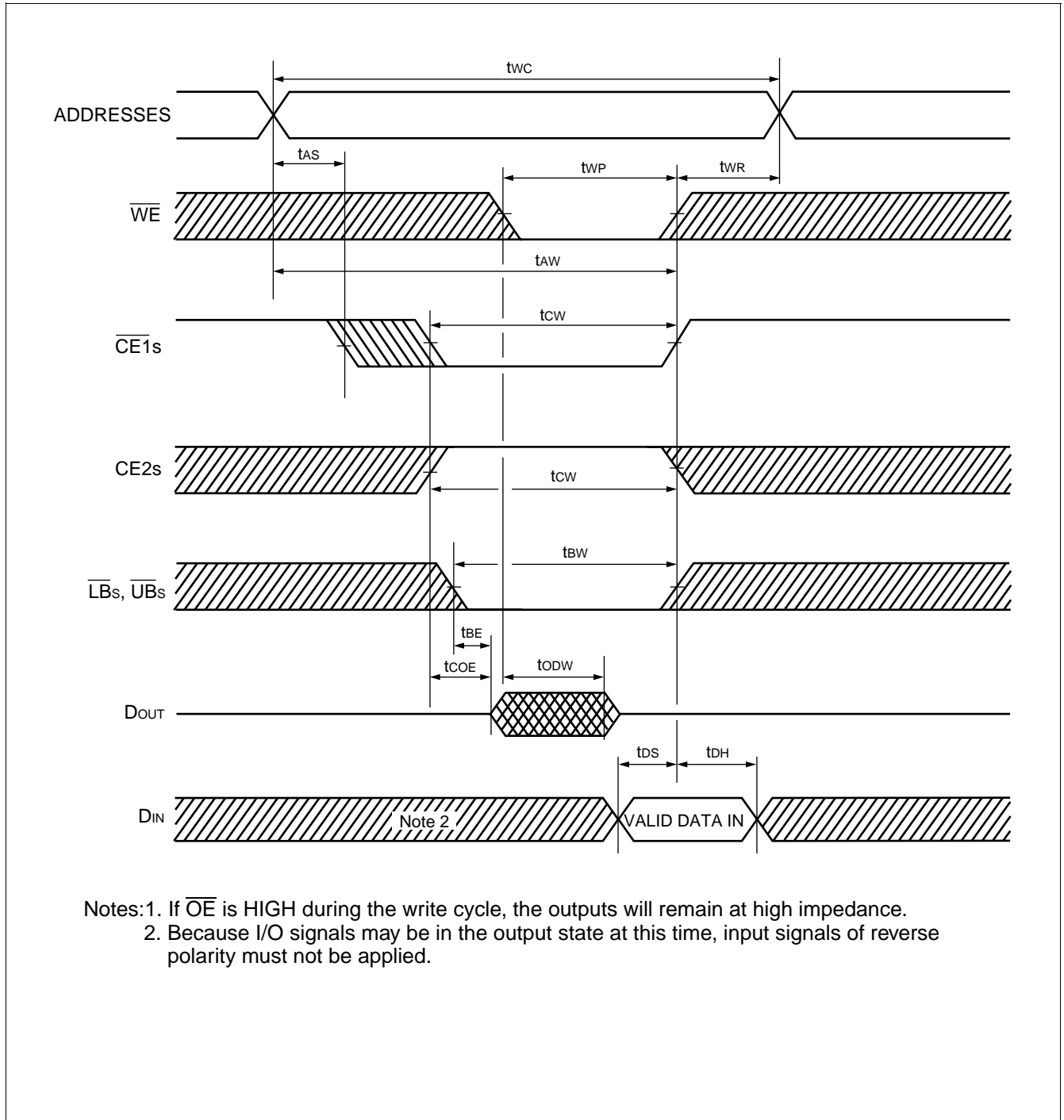

MB84VD2208XEA-90/MB84VD2209XEA-90

• Write Cycle (Note 1) (CE2s Control) (SRAM)

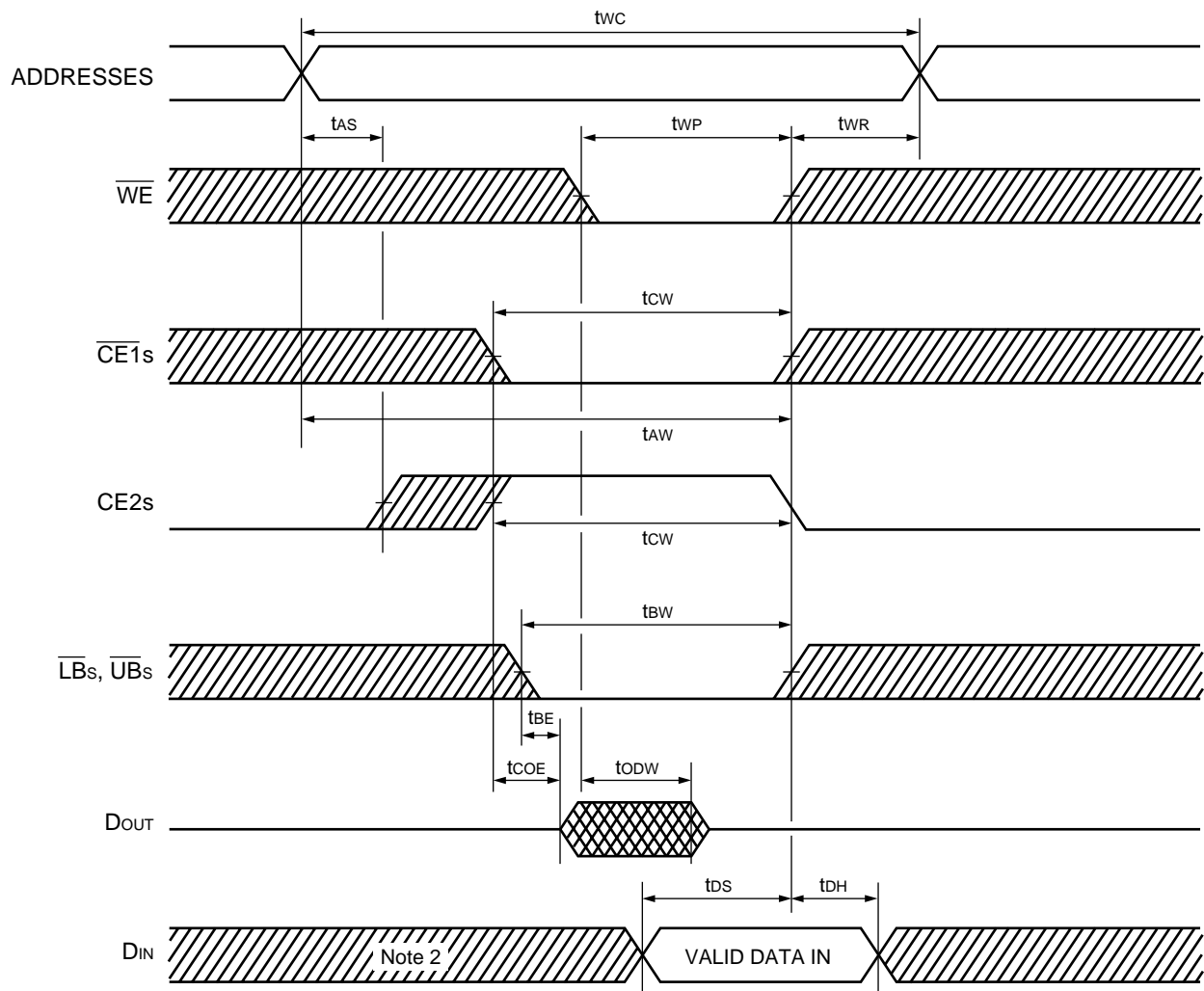

- Notes: 1. If \overline{OE} is HIGH during the write cycle, the outputs will remain at high impedance.
 2. Because I/O signals may be in the output state at this time, input signals of reverse polarity must not be applied.

MB84VD2208XEA-90/MB84VD2209XEA-90

• Write Cycle (Note 1) ($\overline{\text{LBs}}$, $\overline{\text{UBs}}$ Control) (SRAM)

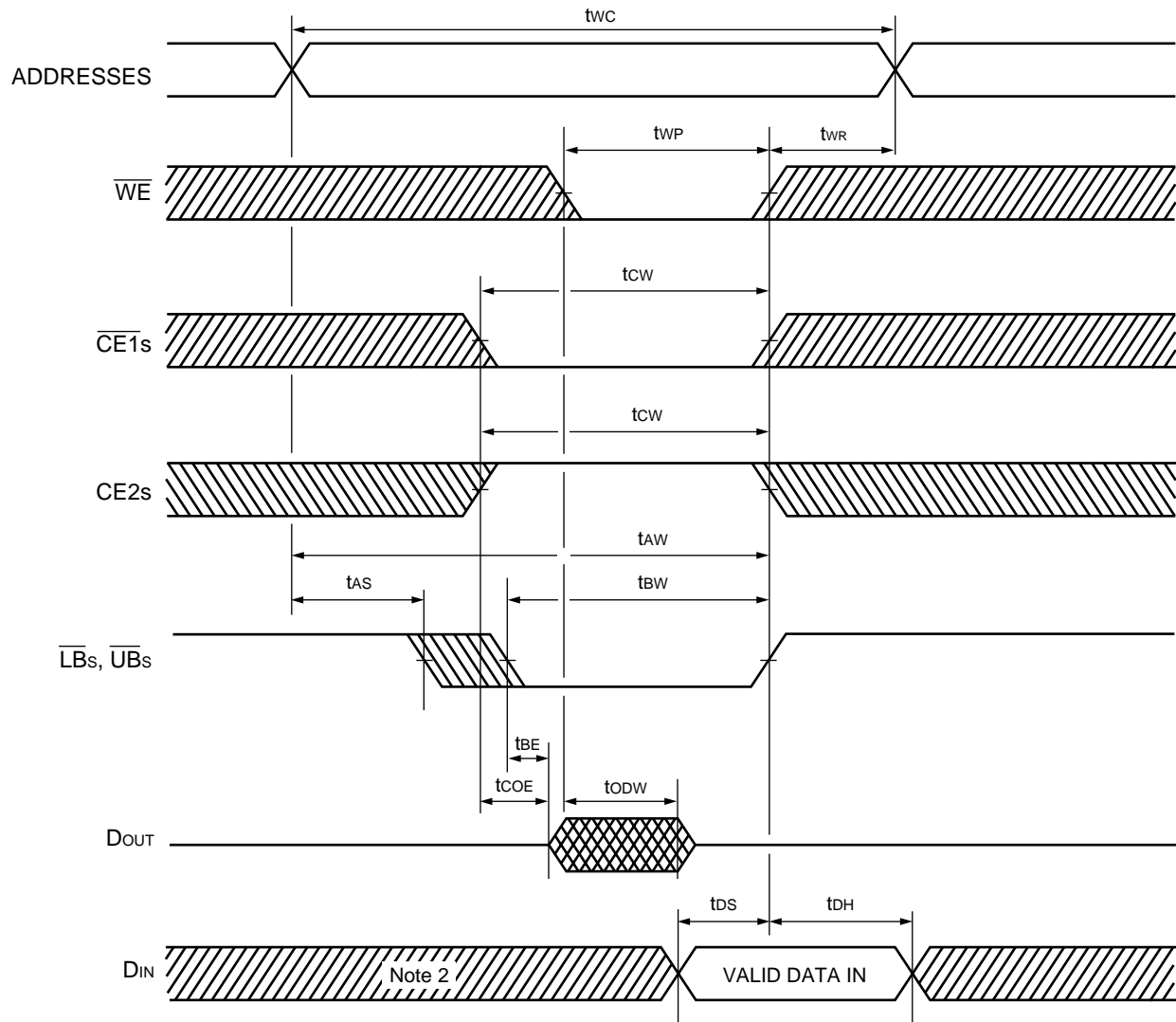

- Notes: 1. If $\overline{\text{OE}}$ is HIGH during the write cycle, the outputs will remain at high impedance.
 2. Because I/O signals may be in the output state at this time, input signals of reverse polarity must not be applied.

MB84VD2208XEA-90/MB84VD2209XEA-90

■ ERASE AND PROGRAMMING PERFORMANCE (Flash)

| Parameter | Limits | | | Unit | Comment |
|-----------------------|---------|------|------|-------|--|
| | Min. | Typ. | Max. | | |
| Sector Erase Time | — | 1 | 10 | s | Excludes programming time prior to erasure |
| Byte Programming Time | — | 8 | 300 | μs | Excludes system-level overhead |
| Word Programming Time | — | 16 | 360 | μs | Excludes system-level overhead |
| Chip Programming Time | — | — | 100 | s | Excludes system-level overhead |
| Erase/Program Cycle | 100,000 | — | — | cycle | |

■ DATA RETENTION CHARACTERISTICS (SRAM)

| Parameter Symbol | Parameter Description | Min. | Typ. | Max. | Unit |
|-------------------|---|-------------------------|------|------|------|
| V _{DH} | Data Retention Supply Voltage | 1.5 | — | 3.3 | V |
| I _{DDs2} | Standby Current | V _{DH} = 3.0 V | 0.2 | 7 | μA |
| t _{CDR} | Chip Deselect to Data Retention Mode Time | 0 | — | — | ns |
| t _R | Recovery Time | t _{RC} | — | — | ns |

Note: t_{RC}: Read cycle time

• $\overline{CE1}$ s Controlled Data Retention Mode (Note 1)

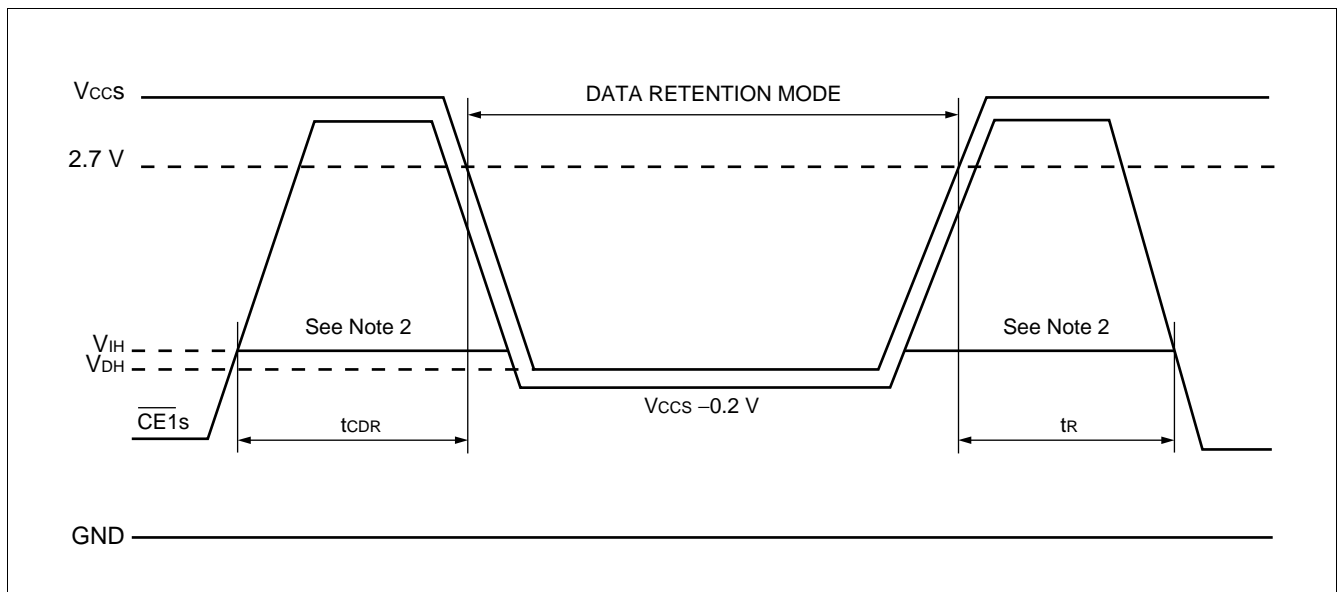

MB84VD2208XEA-90/MB84VD2209XEA-90

• CE2s Controlled Data Retention Mode (Note 3)

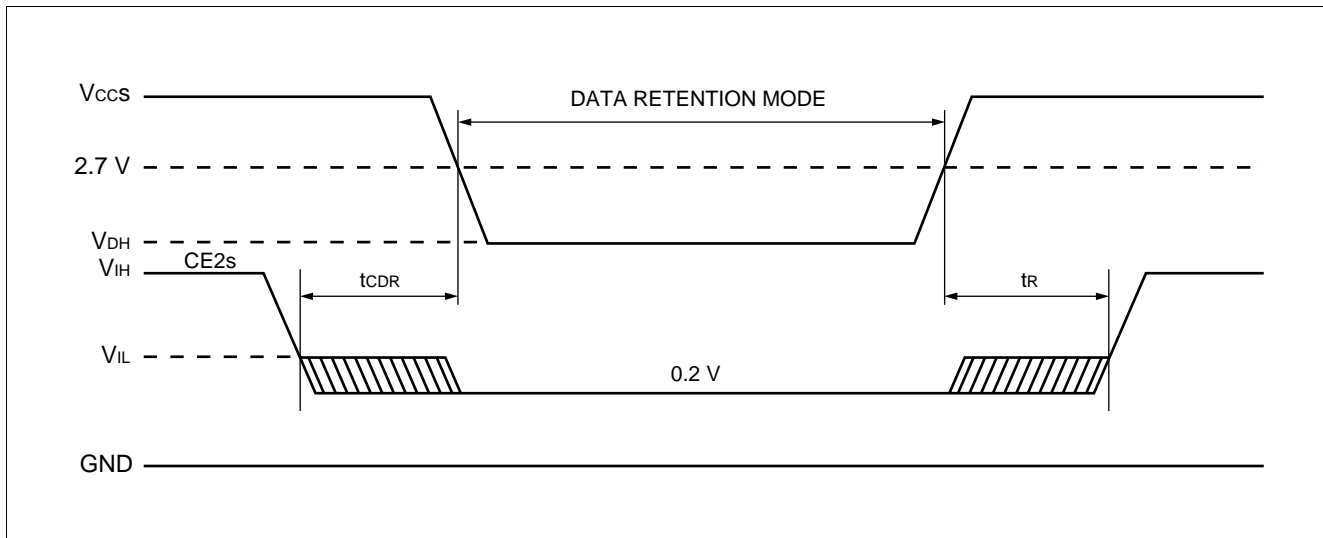

- Notes: 1. In $\overline{CE1}$ s controlled data retention mode, input level of CE2s should be fixed V_{CCS} to $V_{CCS} - 0.2\text{ V}$ or V_{SS} to 0.2 V during data retention mode. Other input and input/output pins can be used between -0.3 V to $V_{CCS} + 0.3\text{ V}$.
2. When $\overline{CE1}$ s is operating at the V_{IH} min. level (2.2 V), the standby current is given by ISB1s during the transition of V_{CCS} from 3.6 to 2.2 V .
3. In CE2s controlled data retention mode, input and input/output pins can be used between -0.3 V to $V_{CCS} + 0.3\text{ V}$.

■ PIN CAPACITANCE

| Parameter Symbol | Parameter Description | Test Setup | Typ. | Max. | Unit |
|------------------|-------------------------------------|---------------|------|------|------|
| C_{IN} | Input Capacitance | $V_{IN} = 0$ | 11 | 14 | pF |
| C_{OUT} | Output Capacitance | $V_{OUT} = 0$ | 12 | 16 | pF |
| C_{IN2} | Control Pin Capacitance | $V_{IN} = 0$ | 14 | 16 | pF |
| C_{IN3} | \overline{WP}/ACC Pin Capacitance | $V_{IN} = 0$ | 21.5 | 26 | pF |

Note: Test conditions $T_a = 25^\circ\text{C}$, $f = 1.0\text{ MHz}$

■ HANDLING OF PACKAGE

Please handle this package carefully since the sides of packages are right angle.

■ CAUTION

- 1) The high voltage (V_{ID}) can not apply to address pins and control pins except \overline{RESET} . Therefore, it can not use autoselect and sector protect function by applying the high voltage (V_{ID}) to specific pins.
- 2) For the sector protection, since the high voltage (V_{ID}) can be applied to the \overline{RESET} , it can be protected the sector using "Extended sector protect" command.

MB84VD2208XEA-90/MB84VD2209XEA-90

■ ORDERING INFORMATION

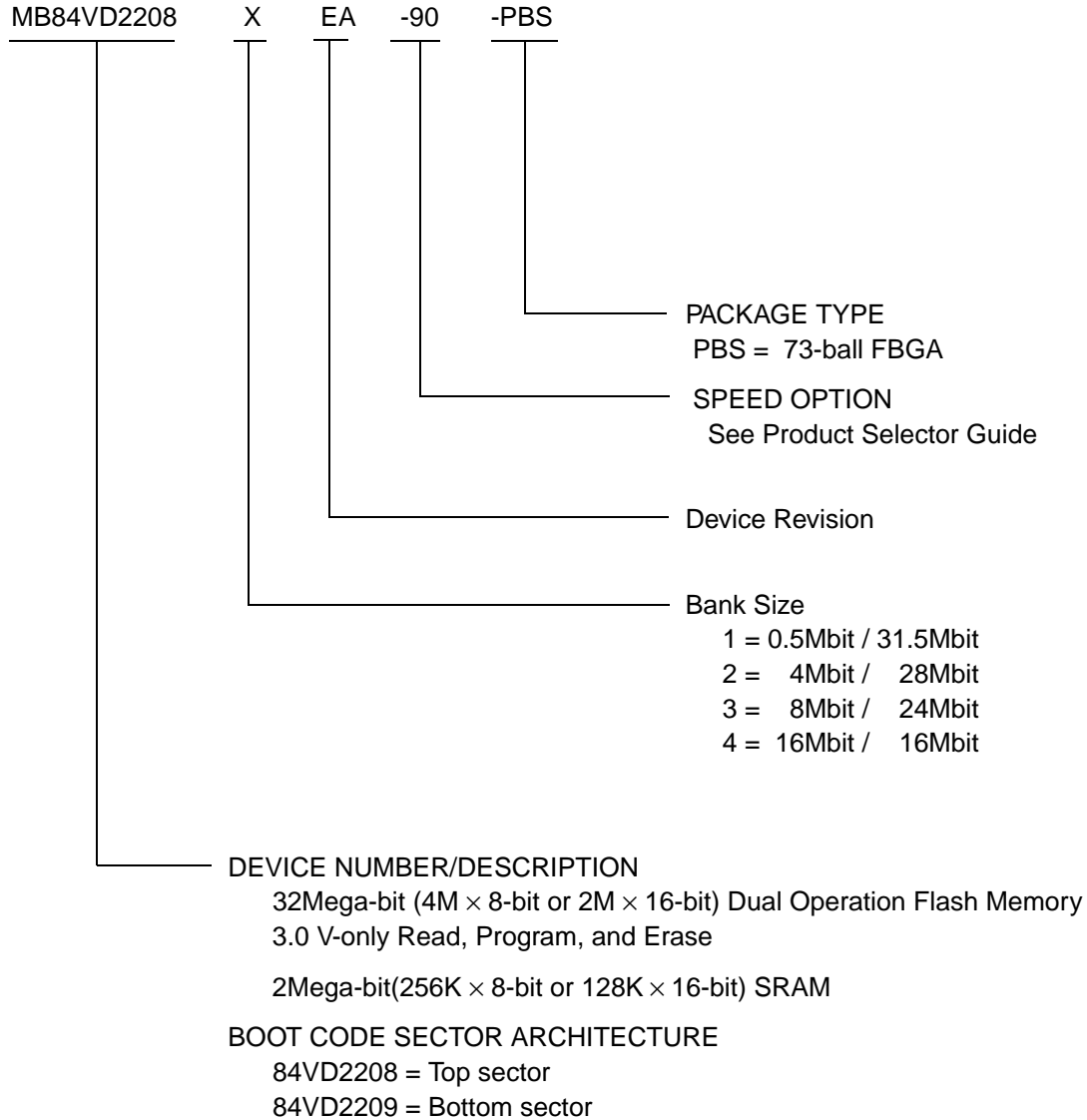

MB84VD2208XEA-90/MB84VD2209XEA-90

■ PACKAGE DIMENSIONS

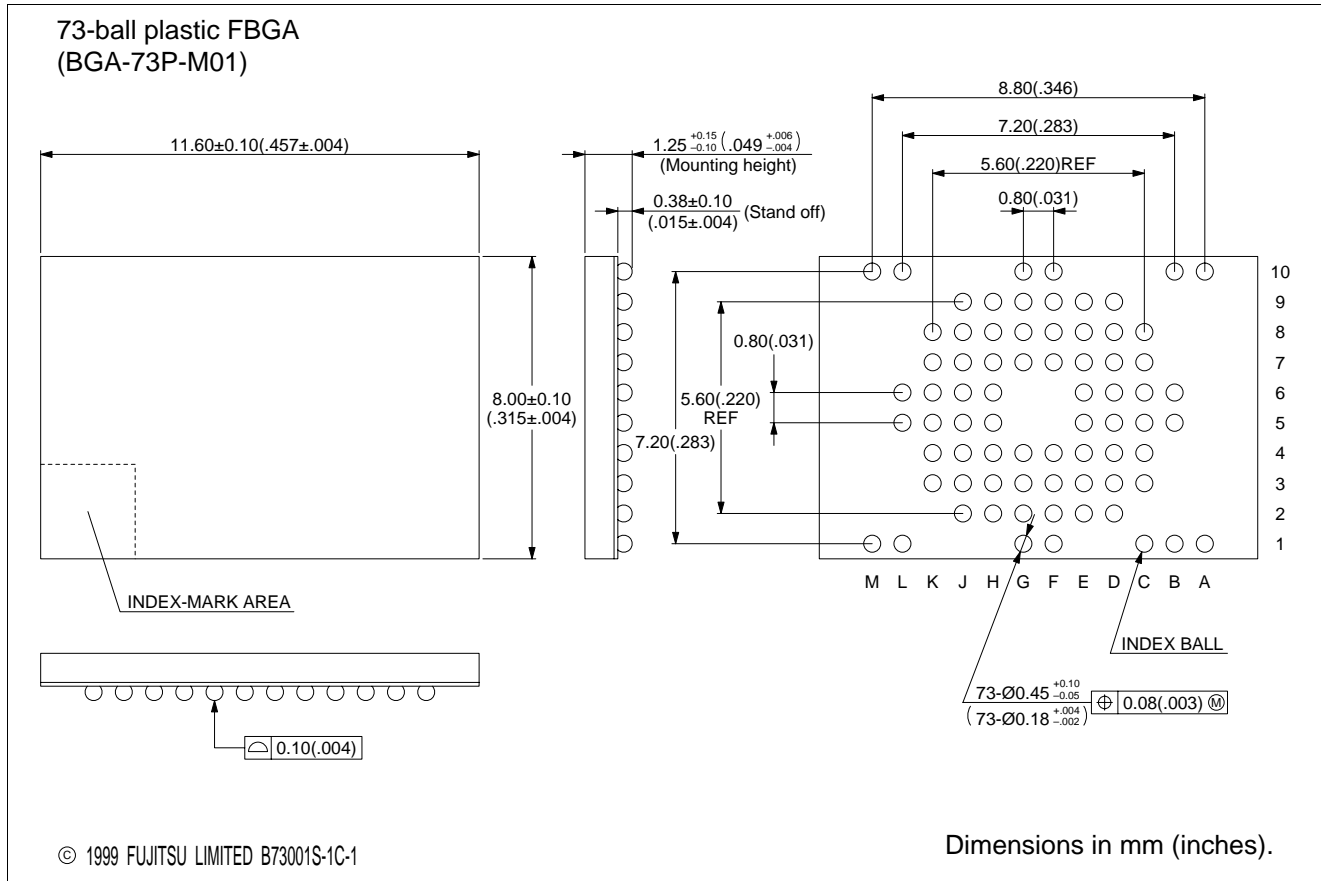

FUJITSU LIMITED

For further information please contact:

Japan

FUJITSU LIMITED
Corporate Global Business Support Division
Electronic Devices
KAWASAKI PLANT, 4-1-1, Kamikodanaka,
Nakahara-ku, Kawasaki-shi,
Kanagawa 211-8588, Japan
Tel: +81-44-754-3763
Fax: +81-44-754-3329

<http://www.fujitsu.co.jp/>

North and South America

FUJITSU MICROELECTRONICS, INC.
3545 North First Street,
San Jose, CA 95134-1804, U.S.A.
Tel: +1-408-922-9000
Fax: +1-408-922-9179

Customer Response Center
Mon. - Fri.: 7 am - 5 pm (PST)
Tel: +1-800-866-8608
Fax: +1-408-922-9179

<http://www.fujitsumicro.com/>

Europe

FUJITSU MICROELECTRONICS EUROPE GmbH
Am Siebenstein 6-10,
D-63303 Dreieich-Buchsschlag,
Germany
Tel: +49-6103-690-0
Fax: +49-6103-690-122

<http://www.fujitsu-fme.com/>

Asia Pacific

FUJITSU MICROELECTRONICS ASIA PTE. LTD.
#05-08, 151 Lorong Chuan,
New Tech Park,
Singapore 556741
Tel: +65-281-0770
Fax: +65-281-0220

<http://www.fmap.com.sg/>

Korea

FUJITSU MICROELECTRONICS KOREA LTD.
1702 KOSMO TOWER, 1002 Daechi-Dong,
Kangnam-Gu, Seoul 135-280
Korea
Tel: +82-2-3484-7100
Fax: +82-2-3484-7111

F0007

© FUJITSU LIMITED Printed in Japan

All Rights Reserved.

The contents of this document are subject to change without notice. Customers are advised to consult with FUJITSU sales representatives before ordering.

The information and circuit diagrams in this document are presented as examples of semiconductor device applications, and are not intended to be incorporated in devices for actual use. Also, FUJITSU is unable to assume responsibility for infringement of any patent rights or other rights of third parties arising from the use of this information or circuit diagrams.

The contents of this document may not be reproduced or copied without the permission of FUJITSU LIMITED.

FUJITSU semiconductor devices are intended for use in standard applications (computers, office automation and other office equipments, industrial, communications, and measurement equipments, personal or household devices, etc.).

CAUTION:

Customers considering the use of our products in special applications where failure or abnormal operation may directly affect human lives or cause physical injury or property damage, or where extremely high levels of reliability are demanded (such as aerospace systems, atomic energy controls, sea floor repeaters, vehicle operating controls, medical devices for life support, etc.) are requested to consult with FUJITSU sales representatives before such use. The company will not be responsible for damages arising from such use without prior approval.

Any semiconductor devices have inherently a certain rate of failure. You must protect against injury, damage or loss from such failures by incorporating safety design measures into your facility and equipment such as redundancy, fire protection, and prevention of over-current levels and other abnormal operating conditions.

If any products described in this document represent goods or technologies subject to certain restrictions on export under the Foreign Exchange and Foreign Trade Control Law of Japan, the prior authorization by Japanese government should be required for export of those products from Japan.