

Linear IC converter

CMOS

D/A Converter for Digital Tuning (8-channel, 8-bit, on-chip OP amp, low-voltage)

MB88347L

■ DESCRIPTION

The MB88347L incorporates eight 8-bit D/A converter modules. This device operates at low supply voltage in the performance guarantee range from 2.7 to 3.6 V. It also contains an output amplifier, allowing driving at large current.

Since the MB88347L inputs data in serial mode, it requires only three control lines for data input and two or more MB88347L units can be cascaded.

The MB88347L is function and pin compatible with the MB88347 (5-volt supply voltage model). The MB88347L can therefore easily replace the MB88347 in a system, thereby reducing the system's voltage requirement.

The MB88347L is the best replacement for electronic variable resistors or screwdriver control resistors.

■ FEATURES

- Ultra-low power consumption (0.5 mW/ch: typical)
- Low voltage operation ($V_{CC} = 2.7$ to 3.6 V)
- Ultra-compact space-saving package (SSOP-16)
- Contains 8-channel R-2R type 8-bit D/A converter
- On-chip analog output amps (sink current max. 1.0 mA, source current max. 1.0 mA)
- Analog output range from 0 V to V_{CC}
- Two separate power supply/ground lines for MCU interface block/operational amplifier output buffer block and D/A converter block
- Serial data input, maximum operating speed 2.5 MHz
- CMOS process
- Package lineup includes DIP 16-pin, SOP 16-pin, SSOP 16-pin

■ PACKAGES

16 pin, Plastic DIP

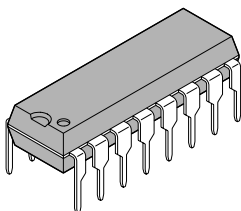

(DIP-16P-M04)

16 pin, Plastic SOP

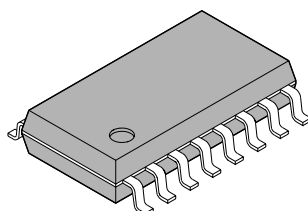

(FPT-16P-M06)

16 pin, Plastic SSOP

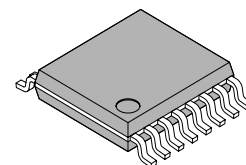

(FPT-16P-M05)

MB88347L

■ PIN ASSIGNMENT

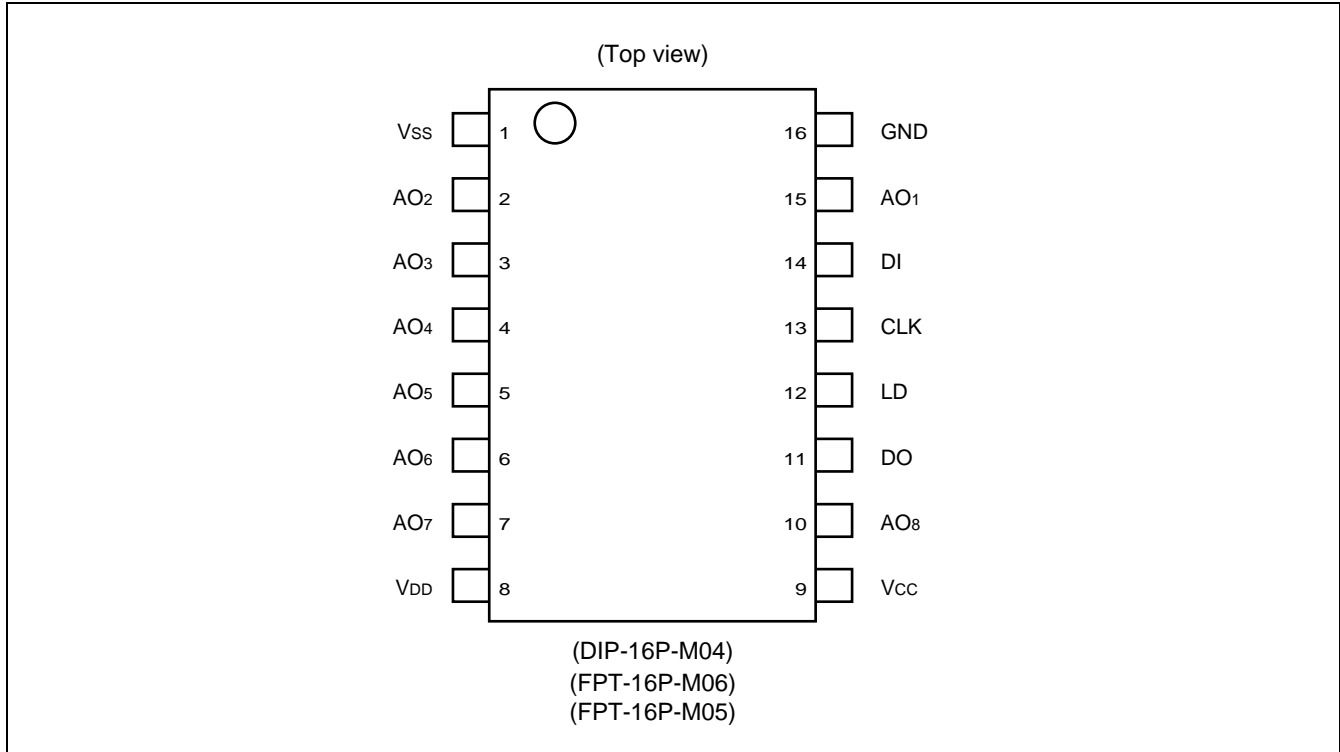

■ PIN DESCRIPTION

Pin No.	Pin name	I/O	Functions
14	DI	I	Serial data input pin. This pin inputs serial data with a data length of 12 bits. (Do not leave the pin floating.)
11	DO	O	This pin outputs the MSB data in the 12-bit shift register at the CLK falling edge.
13	CLK	I	Shift clock input pin. The input signal from the DI pin enters the 12-bit shift register at the rising edge of the shift clock pulse. (Do not leave this pin floating.)
12	LD	I	When the LD pin inputs the High-level signal, shift register value is loaded to the decoder and the D/A output register. (Do not leave this pin floating. When data is not transferred, fix the pin to the "Low" level.)
15 2 3 4 5 6 7 10	AO ₁ AO ₂ AO ₃ AO ₄ AO ₅ AO ₆ AO ₇ AO ₈	O	8-bit D/A output with op amp.
9	V _{CC}	—	MCU interface and OP amp power-supply pin.
16	GND	—	MCU interface and OP amp GND pin.
8	V _{DD}	—	D/A converter reference power (High) input pin.
1	V _{SS}	—	D/A converter reference power (Low) input pin.

■ BLOCK DIAGRAM

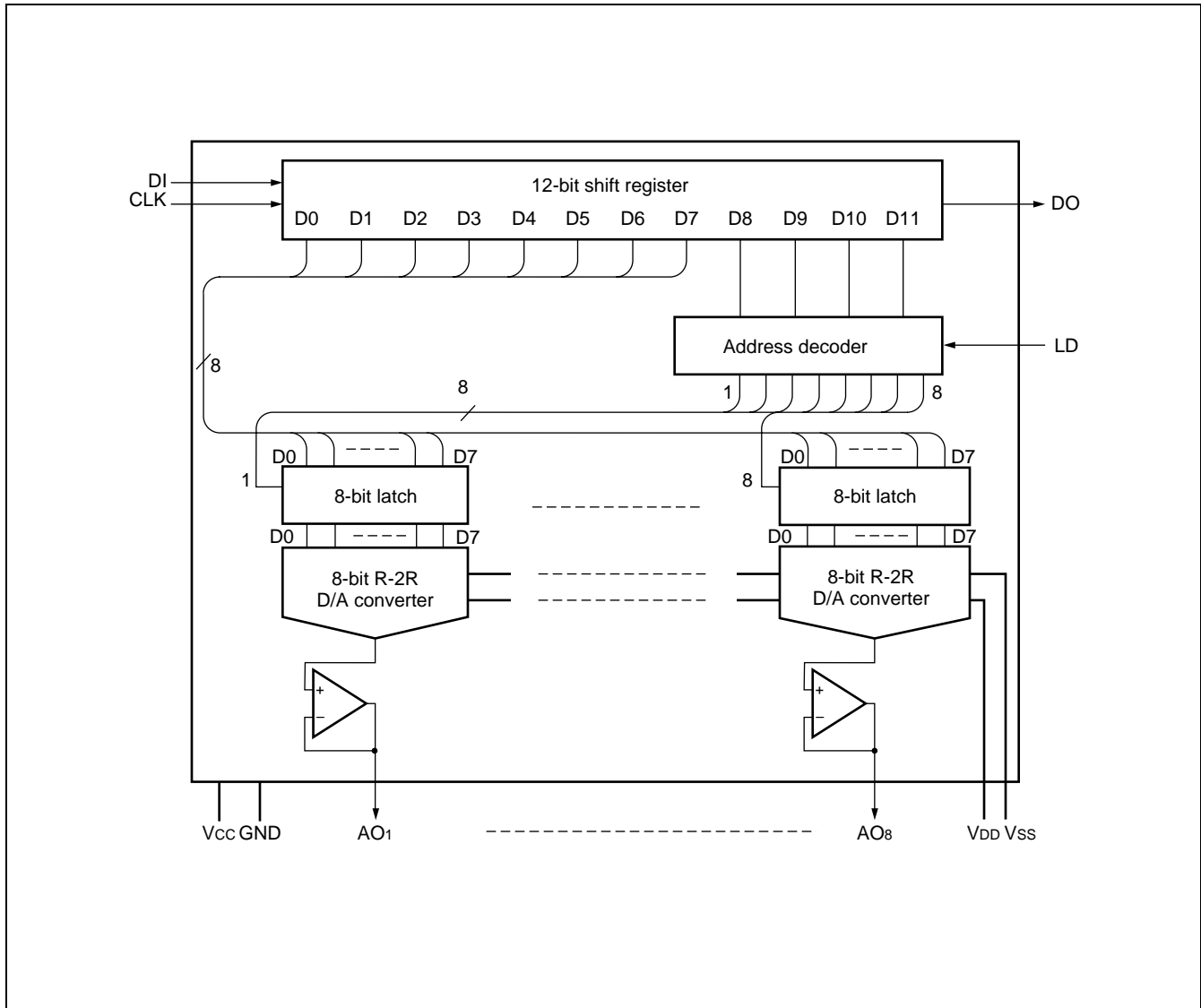

MB88347L

■ DATA CONFIGURATION

The MB88347L has a 12-bit shift register for chip control.

The 12-bit shift register must be used to set up data in the configuration shown below.

The data configuration has a total of 12 bits, for address selection and eight for D/A data output.

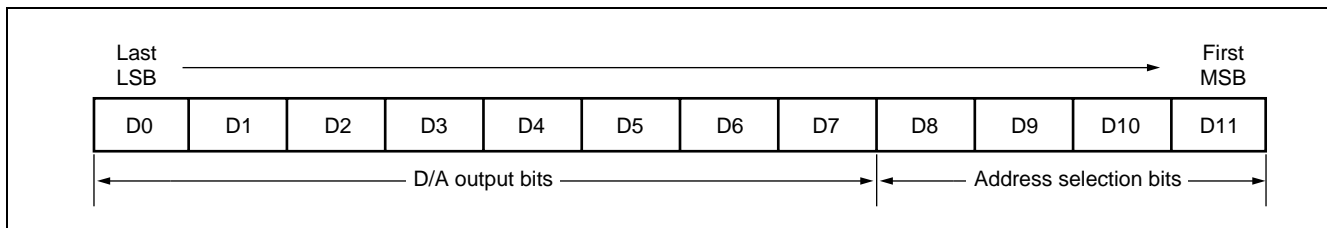

• D/A converter control signals

D0	D1	D2	D3	D4	D5	D6	D7	D/A data output
0	0	0	0	0	0	0	0	$\equiv V_{SS}$
1	0	0	0	0	0	0	0	$\equiv V_{LB} \times 1 + V_{SS}$
0	1	0	0	0	0	0	0	$\equiv V_{LB} \times 2 + V_{SS}$
⋮	⋮	⋮	⋮	⋮	⋮	⋮	⋮	⋮
0	1	1	1	1	1	1	1	$\equiv V_{LB} \times 254 + V_{SS}$
1	1	1	1	1	1	1	1	$\equiv V_{LB} \times 255 + V_{SS}$

Note: $V_{LB} = (V_{DD} - V_{SS})/256$

• Address selection signals

D8	D9	D10	D11	Address selection
0	0	0	0	Don't Care
0	0	0	1	AO ₁ Selection
0	0	1	0	AO ₂ Selection
0	0	1	1	AO ₃ Selection
0	1	0	0	AO ₄ Selection
0	1	0	1	AO ₅ Selection
0	1	1	0	AO ₆ Selection
0	1	1	1	AO ₇ Selection
1	0	0	0	AO ₈ Selection
1	0	0	1	Don't Care
1	0	1	0	Don't Care
1	0	1	1	Don't Care
1	1	0	0	Don't Care
1	1	0	1	Don't Care
1	1	1	0	Don't Care
1	1	1	1	Don't Care

DATA SETTING TIMING CHART

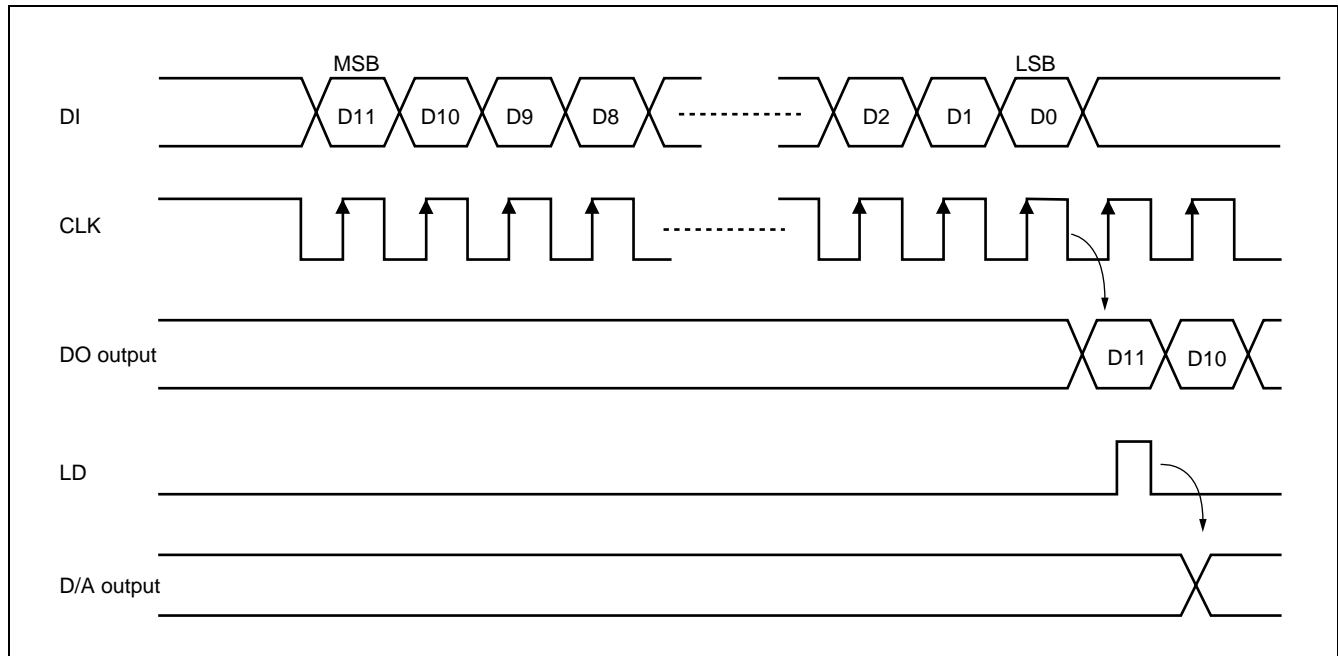

ANALOG OUTPUT VOLTAGE RANGE

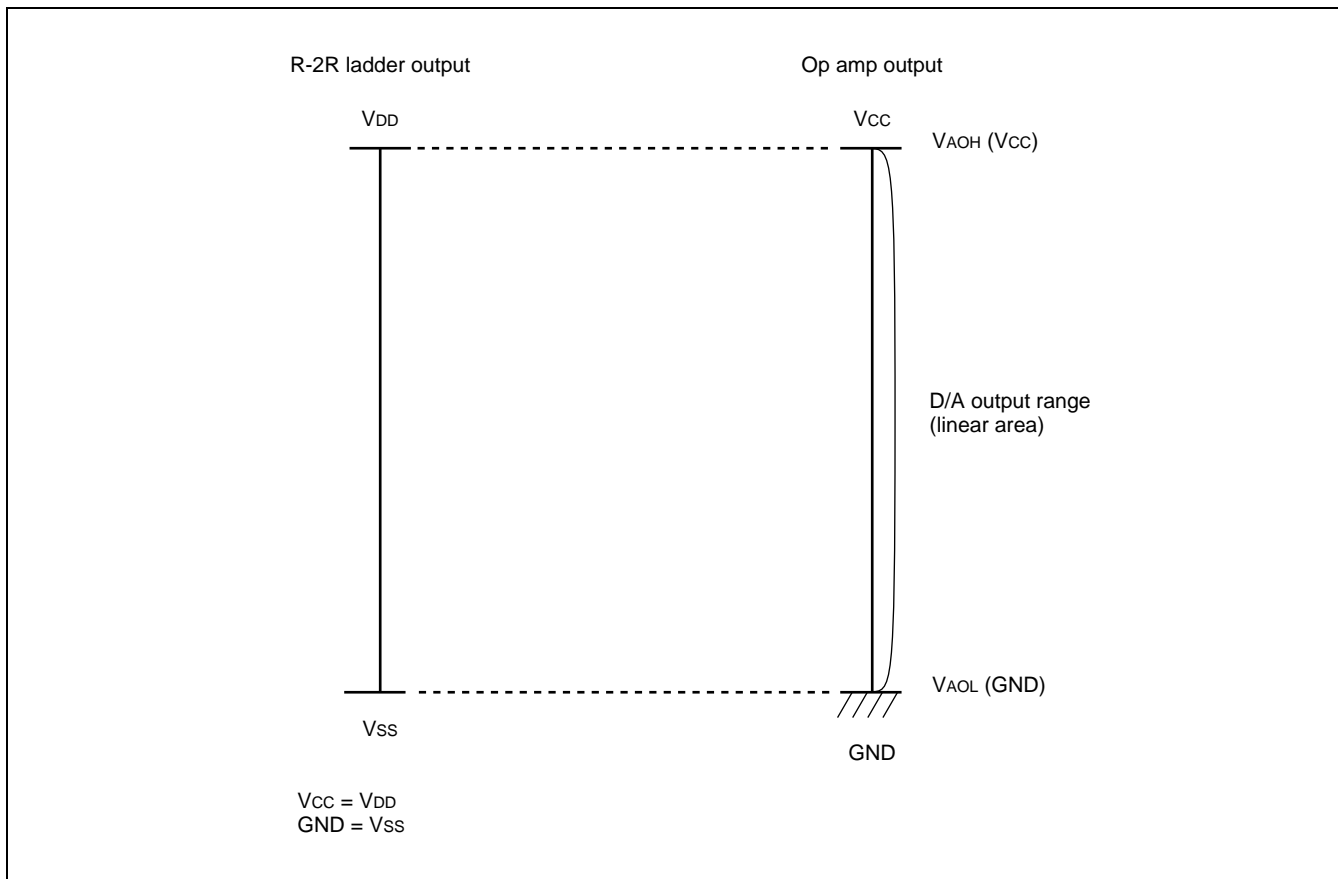

MB88347L

■ ABSOLUTE MAXIMUM RATINGS

Parameter	Symbol	Conditions	Rating		Unit
			Min.	Max.	
Supply voltage	V _{CC}	Based on GND Ta = +25°C	-0.3	5.0	V
	V _{DD}		-0.3*	5.0*	V
Input voltage	V _{IN}		-0.3	V _{CC} + 0.3	V
Output voltage	V _{OUT}		-0.3	V _{CC} + 0.3	V
Power consumption	P _D	—	—	250	mW
Operating temperature	Ta	—	-20	+85	°C
Storage temperature	T _{stg}	—	-55	+150	°C

* : V_{CC} ≥ V_{DD}

WARNING: Semiconductor devices can be permanently damaged by application of stress (voltage, current, temperature, etc.) in excess of absolute maximum ratings. Do not exceed these ratings.

■ RECOMMENDED OPERATING CONDITIONS

Parameter	Symbol	Conditions	Rating		Unit
			Min.	Max.	
Power supply voltage 1	V _{CC}	—	2.7	3.6	V
	GND	—	Typical: 0		V
Power supply voltage 2	V _{DD}	V _{DD} - V _{SS} ≥ 2.0 V	2.0	V _{CC}	V
	V _{SS}		GND	V _{CC} - 2.0	V
Analog output source current	I _{AL}	V _{CC} = 3.0 V	—	1.0	mA
Analog output sink current	I _{AH}	V _{CC} = 3.0 V	—	1.0	mA
Oscillation limit output capacity	C _{OL}	—	—	1.0	μF
Digital data value range	—	—	#00	#FF	—
Operating temperature	Ta	—	-20	+85	°C

WARNING: The recommended operating conditions are required in order to ensure the normal operation of the semiconductor device. All of the device's electrical characteristics are warranted when the device is operated within these ranges.

Always use semiconductor devices within their recommended operating condition ranges. Operation outside these ranges may adversely affect reliability and could result in device failure.

No warranty is made with respect to uses, operating conditions, or combinations not represented on the data sheet. Users considering application outside the listed conditions are advised to contact their FUJITSU representatives beforehand.

■ ELECTRICAL CHARACTERISTICS

1. DC Characteristics

(1) Digital block

($V_{DD}, V_{CC} = 2.7\text{ V to }3.6\text{ V}$ ($V_{CC} \geq V_{DD}$), GND, $V_{SS} = 0\text{ V}$, $T_a = -20^\circ\text{C to }+85^\circ\text{C}$)

Parameter	Symbol	Pin name	Conditions	Value			Unit
				Min.	Typ.	Max.	
Power supply voltage	V_{CC}	V_{CC}	—	2.7	3.0	3.6	V
Power supply current 1	I_{CC}		Operation at CLK = 1 MHz (with no load)	—	0.8	2.0	mA
Input leak current	I_{ILK}	CLK DI LD	$V_{IN} = 0\text{ V to }V_{CC}$	-10	—	10	μA
L level input voltage	V_{IL}		—	—	—	$0.2 V_{CC}$	V
H level input voltage	V_{IH}		—	$0.8 V_{CC}$	—	—	V
L level output voltage	V_{OL}	DO	$I_{OL} = 2.5\text{ mA}$	—	—	0.4	V
H level output voltage	V_{OH}		$I_{OH} = -400\ \mu\text{A}$	$V_{CC} - 0.4$	—	—	V

(2) Analog block (1)

($V_{DD}, V_{CC} = 2.7\text{ V to }3.6\text{ V}$ ($V_{CC} \geq V_{DD}$), GND, $V_{SS} = 0\text{ V}$, $T_a = -20^\circ\text{C to }+85^\circ\text{C}$)

Parameter	Symbol	Pin name	Conditions	Value			Unit
				Min.	Typ.	Max.	
Power consumption	I_{DD}	V_{DD}	No load	—	0.6	1.0	mA
Analog voltage	V_{DD}	V_{DD}	$V_{DD} - V_{SS} \geq 2.0\text{ V}$	2.0	—	V_{CC}	V
	V_{SS}	V_{SS}		GND	—	$V_{CC} - 2.0$	V
Resolution	Res	AO ₁ to AO ₈	—	—	8	—	bits
Monotonic increase	Rem		—	—	8	—	bits
Non-linearity error*1	LE		No load $V_{DD} \leq V_{CC} - 0.1\text{ V}$ $V_{SS} \geq 0.1\text{ V}$	-1.5	—	1.5	LSB
Differential linearity error*2	DLE		—	-1.0	—	1.0	LSB

*1: Deviation (error) in input/output curves with respect to an ideal straight line connecting output voltage at “00” and output voltage at “FF.”

*2: Deviation (error) in amplification with respect to theoretical increase in amplification per 1-bit increase in digital value.

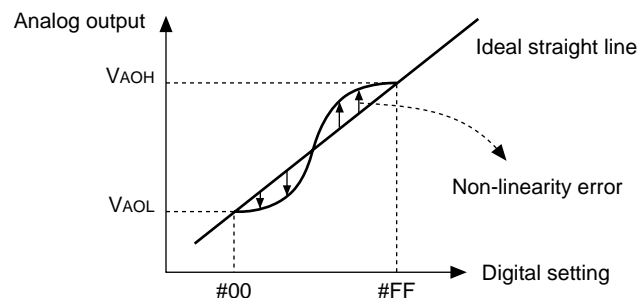

Note: The value of V_{AOH} and V_{DD} , and the value of V_{AOL} and V_{SS} are not necessarily equivalent.

MB88347L

(3) Analog section (2)

(Ta = -20°C to +85°C)

Parameter	Symbol	Pin name	Conditions	Values			Unit
				Min.	Typ.	Max.	
Output minimum voltage 1	VAOL1	AO ₁ to AO ₈	V _{DD} = V _{CC} = 3.0 V V _{SS} = GND = 0.0 V I _{AL} = 0 μA Digital data = #00	V _{SS}	—	V _{SS} + 0.1	V
Output minimum voltage 2	VAOL2		V _{DD} = V _{CC} = 3.0 V V _{SS} = GND = 0.0 V I _{AL} = 500 μA Digital data = #00	V _{SS} - 0.2	V _{SS}	V _{SS} + 0.2	V
Output minimum voltage 3	VAOL3		V _{DD} = V _{CC} = 3.0 V V _{SS} = GND = 0.0 V I _{AH} = 500 μA Digital data = #00	V _{SS}	—	V _{SS} + 0.2	V
Output minimum voltage 4	VAOL4		V _{DD} = V _{CC} = 3.0 V V _{SS} = GND = 0.0 V I _{AL} = 1.0 mA Digital data = #00	V _{SS} - 0.3	V _{SS}	V _{SS} + 0.3	V
Output minimum voltage 5	VAOL5		V _{DD} = V _{CC} = 3.0 V V _{SS} = GND = 0.0 V I _{AH} = 1.0 mA Digital data = #00	V _{SS}	—	V _{SS} + 0.3	V
Output maximum voltage 1	VAOH1		V _{DD} = V _{CC} = 3.0 V V _{SS} = GND = 0.0 V I _{AL} = 0 μA Digital data = #FF	V _{DD} - 0.1	—	V _{DD}	V
Output maximum voltage 2	VAOH2		V _{DD} = V _{CC} = 3.0 V V _{SS} = GND = 0.0 V I _{AL} = 500 μA Digital data = #FF	V _{DD} - 0.2	—	V _{DD}	V
Output maximum voltage 3	VAOH3		V _{DD} = V _{CC} = 3.0 V V _{SS} = GND = 0.0 V I _{AH} = 500 μA Digital data = #FF	V _{DD} - 0.2	V _{DD}	V _{DD} + 0.2	V
Output maximum voltage 4	VAOH4		V _{DD} = V _{CC} = 3.0 V V _{SS} = GND = 0.0 V I _{AL} = 1.0 mA Digital data = #FF	V _{DD} - 0.3	—	V _{DD}	V
Output maximum voltage 5	VAOH5		V _{DD} = V _{CC} = 3.0 V V _{SS} = GND = 0.0 V I _{AH} = 1.0 mA Digital data = #FF	V _{DD} - 0.3	V _{DD}	V _{DD} + 0.3	V

2. AC Characteristics

(V_{DD} , $V_{CC} = 2.7\text{ V to }3.6\text{ V}$ ($V_{CC} \geq V_{DD}$), GND , $V_{SS} = 0\text{ V}$, $T_a = -20^\circ\text{C to }+85^\circ\text{C}$)

Parameter	Symbol	Conditions	Rating		Unit
			Min.	Max.	
Clock L level pulse width	t _{CKL}	—	200	—	ns
Clock H level pulse width	t _{CKH}	—	200	—	ns
Clock rise time Clock fall time	t _{Cr} t _{Cf}	—	—	200	ns
Data setup time	t _{DCH}	—	30	—	ns
Data hold time	t _{CHD}	—	60	—	ns
Load setup time	t _{CHL}	—	200	—	ns
Load hold time	t _{LDC}	—	100	—	ns
Load H level pulse width	t _{LDH}	—	100	—	ns
Data output delay time	t _{DO}	See "Load conditions (1)."	—	170	ns
D/A output settling time	t _{LDD}	See "Load conditions (2)."	—	200	μs

Load conditions

- Load conditions (1)

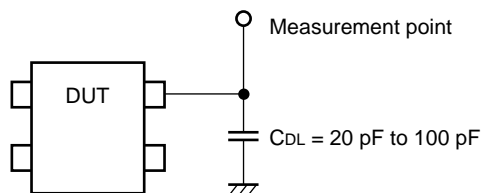

- Load conditions (2)

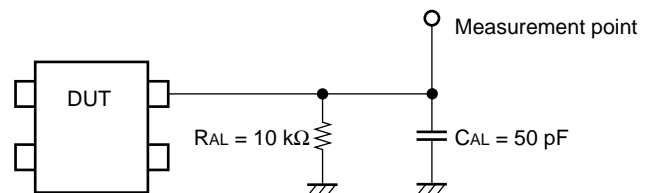

MB88347L

Input/output timing

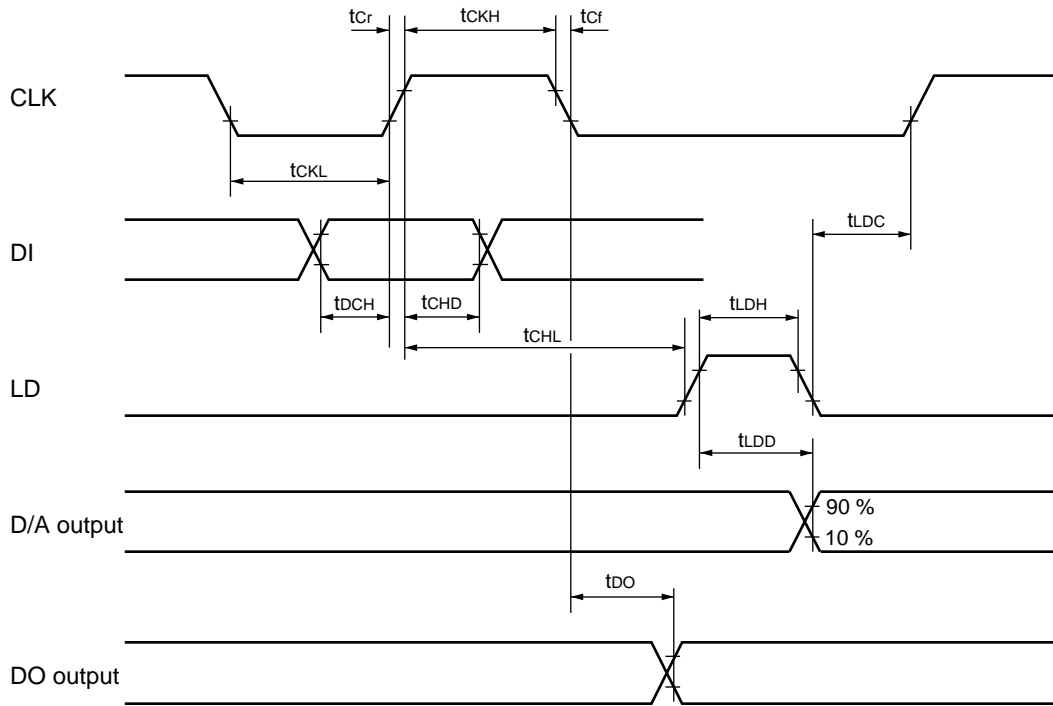

Note: Evaluation levels are 80% and 20% of V_{CC} .

■ V_{AO} vs. I_{AO} CHARACTERISTICS: EXAMPLE

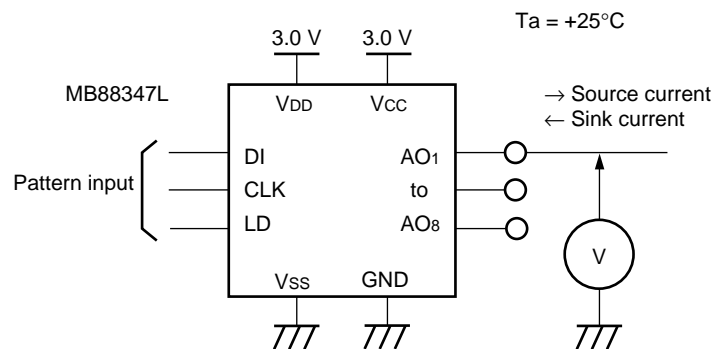

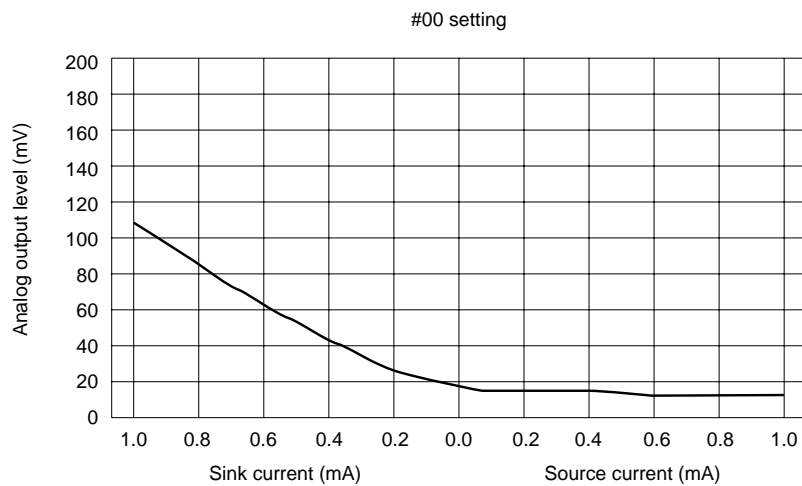
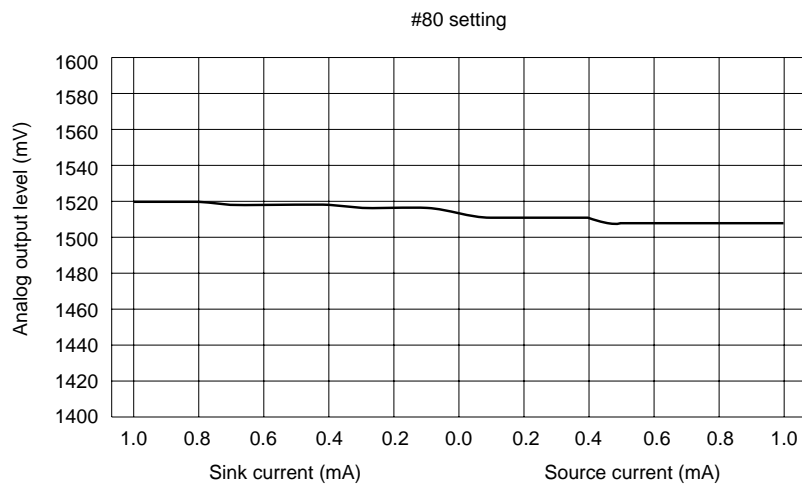
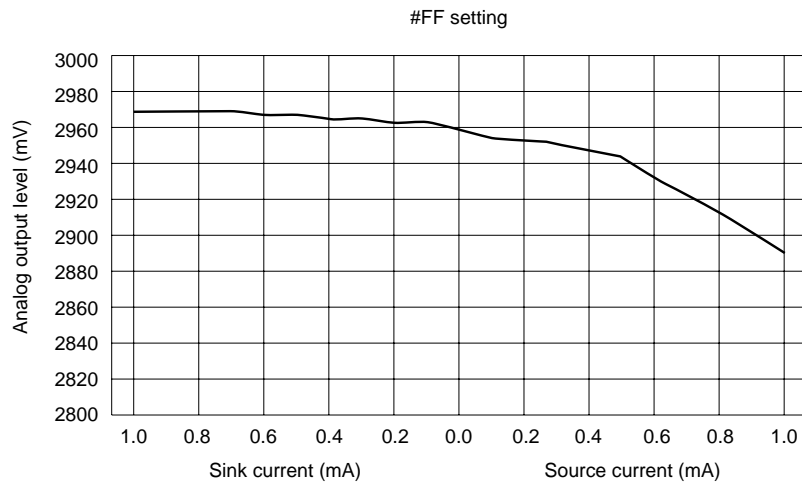

MB88347L

■ ORDERING INFORMATION

Part number	Package	Remarks
MB88347LP	16 pin, Plastic DIP (DIP-16P-M04)	
MB88347LPF	16 pin, Plastic SOP (FPT-16P-M06)	
MB88347LPFV	16 pin, Plastic SSOP (FPT-16P-M05)	

■ PACKAGE DIMENSIONS

16 pin, Plastic DIP
(DIP-16P-M04)

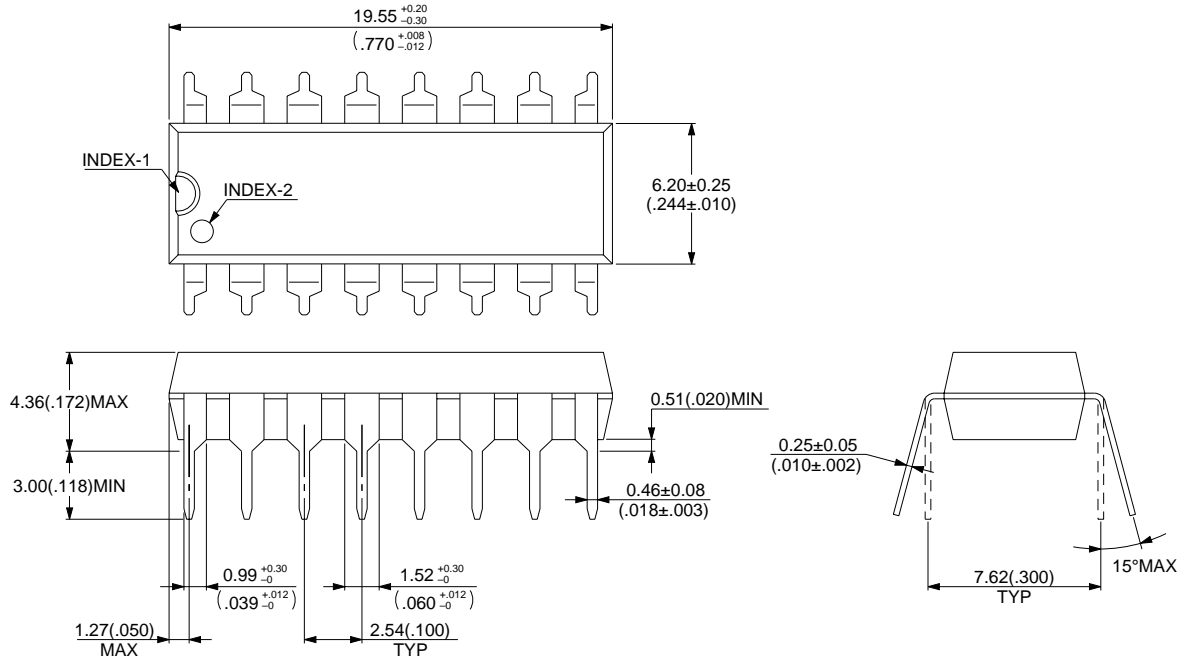

© 1994 FUJITSU LIMITED D16033S-2C-3

Dimensions in mm (inches).

(Continued)

MB88347L

16 pin, Plastic SOP
(FPT-16P-M06)

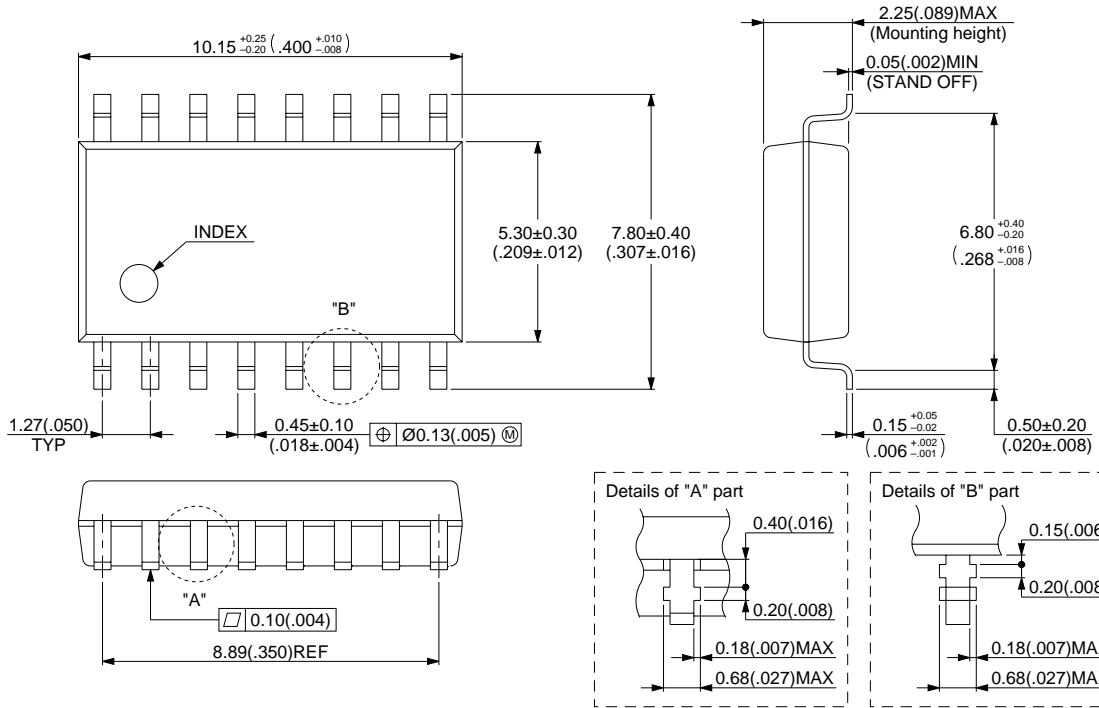

Dimensions in mm (inches).

© 1994 FUJITSU LIMITED F16015S-2C-4

(Continued)

16 pin, Plastic SSOP
(FPT-16P-M05)

Note 1) *: These dimensions do not include resin protrusion.
Note 2) Pins width and pins thickness include plating thickness.

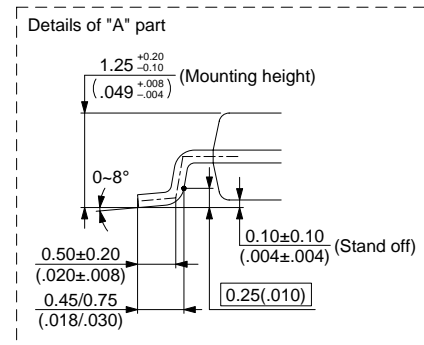
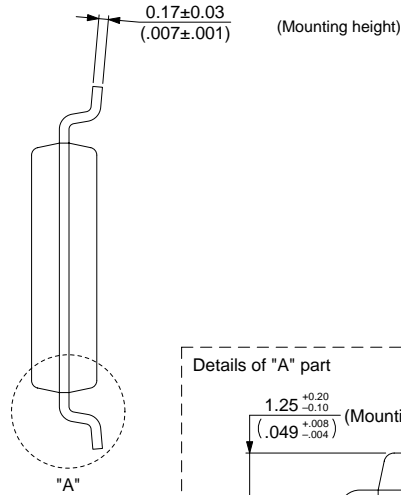
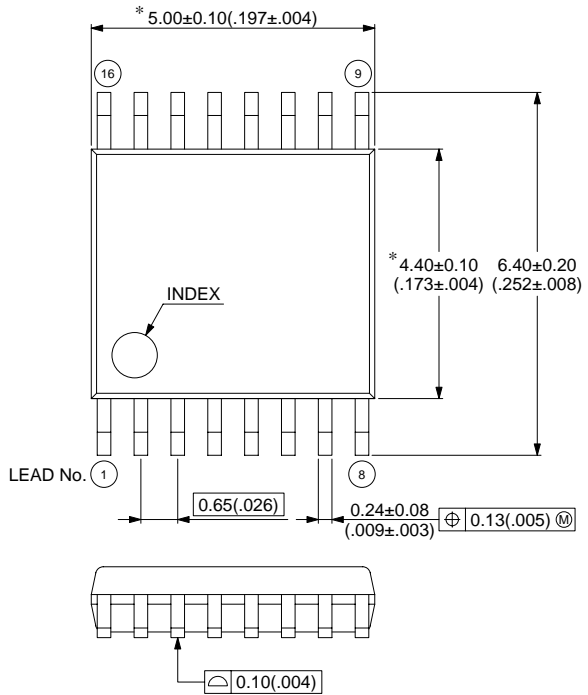

Dimensions in mm (inches).

FUJITSU LIMITED

For further information please contact:

Japan

FUJITSU LIMITED
Corporate Global Business Support Division
Electronic Devices
KAWASAKI PLANT, 4-1-1, Kamikodanaka,
Nakahara-ku, Kawasaki-shi,
Kanagawa 211-8588, Japan
Tel: +81-44-754-3763
Fax: +81-44-754-3329

<http://www.fujitsu.co.jp/>

North and South America

FUJITSU MICROELECTRONICS, INC.
3545 North First Street,
San Jose, CA 95134-1804, USA
Tel: +1-408-922-9000
Fax: +1-408-922-9179

Customer Response Center
Mon. - Fri.: 7 am - 5 pm (PST)
Tel: +1-800-866-8608
Fax: +1-408-922-9179

<http://www.fujitsumicro.com/>

Europe

FUJITSU MICROELECTRONICS EUROPE GmbH
Am Siebenstein 6-10,
D-63303 Dreieich-Buchsschlag,
Germany
Tel: +49-6103-690-0
Fax: +49-6103-690-122

<http://www.fujitsu-fme.com/>

Asia Pacific

FUJITSU MICROELECTRONICS ASIA PTE LTD
#05-08, 151 Lorong Chuan,
New Tech Park,
Singapore 556741
Tel: +65-281-0770
Fax: +65-281-0220

<http://www.fmap.com.sg/>

F0001

© FUJITSU LIMITED Printed in Japan

All Rights Reserved.

The contents of this document are subject to change without notice.

Customers are advised to consult with FUJITSU sales representatives before ordering.

The information and circuit diagrams in this document are presented as examples of semiconductor device applications, and are not intended to be incorporated in devices for actual use. Also, FUJITSU is unable to assume responsibility for infringement of any patent rights or other rights of third parties arising from the use of this information or circuit diagrams.

The contents of this document may not be reproduced or copied without the permission of FUJITSU LIMITED.

FUJITSU semiconductor devices are intended for use in standard applications (computers, office automation and other office equipments, industrial, communications, and measurement equipments, personal or household devices, etc.).
CAUTION:

Customers considering the use of our products in special applications where failure or abnormal operation may directly affect human lives or cause physical injury or property damage, or where extremely high levels of reliability are demanded (such as aerospace systems, atomic energy controls, sea floor repeaters, vehicle operating controls, medical devices for life support, etc.) are requested to consult with FUJITSU sales representatives before such use. The company will not be responsible for damages arising from such use without prior approval.

Any semiconductor devices have inherently a certain rate of failure. You must protect against injury, damage or loss from such failures by incorporating safety design measures into your facility and equipment such as redundancy, fire protection, and prevention of over-current levels and other abnormal operating conditions.

If any products described in this document represent goods or technologies subject to certain restrictions on export under the Foreign Exchange and Foreign Trade Control Law of Japan, the prior authorization by Japanese government should be required for export of those products from Japan.