

FLASH MEMORY

CMOS

32M (4M × 8) BIT

MBM29F033C-70/-90/-12

■ FEATURES

- **Single 5.0 V read, write, and erase**
Minimizes system level power requirements
- **Compatible with JEDEC-standard commands**
Pinout and software compatible with single-power supply Flash
Superior inadvertent write protection
- **40-pin TSOP (I) (Package suffix: PTN-Normal Bend Type, PTR-Reversed Bend Type)**
- **Minimum 100,000 write/erase cycles**
- **High performance**
70 ns maximum access time
- **Sector erase architecture**
Uniform sectors of 64K bytes each
Any combination of sectors can be erased. Also supports full chip erase
- **Embedded Erase™ Algorithms**
Automatically preprograms and erases the chip or any sector
- **Embedded Program™ Algorithms**
Automatically programs and verifies data at specified address
- **Data Polling and Toggle Bit feature for detection of program or erase cycle completion**
- **Ready/BUSY output (RY/BY)**
Hardware method for detection of program or erase cycle completion
- **Low V_{cc} write inhibit ≤ 3.2 V**
- **Hardware RESET pin**
Resets internal state machine to the read mode
- **Erase Suspend/Resume**
Supports reading or programming data to a sector not being erased
- **Sector group protection**
Hardware method that disables any combination of sector groups from write or erase operation (a sector group consists of 4 adjacent sectors of 64K bytes each)
- **Temporary sector groups unprotection**
Hardware method temporarily enable any combination of sectors from write or erase operations

■ PACKAGE

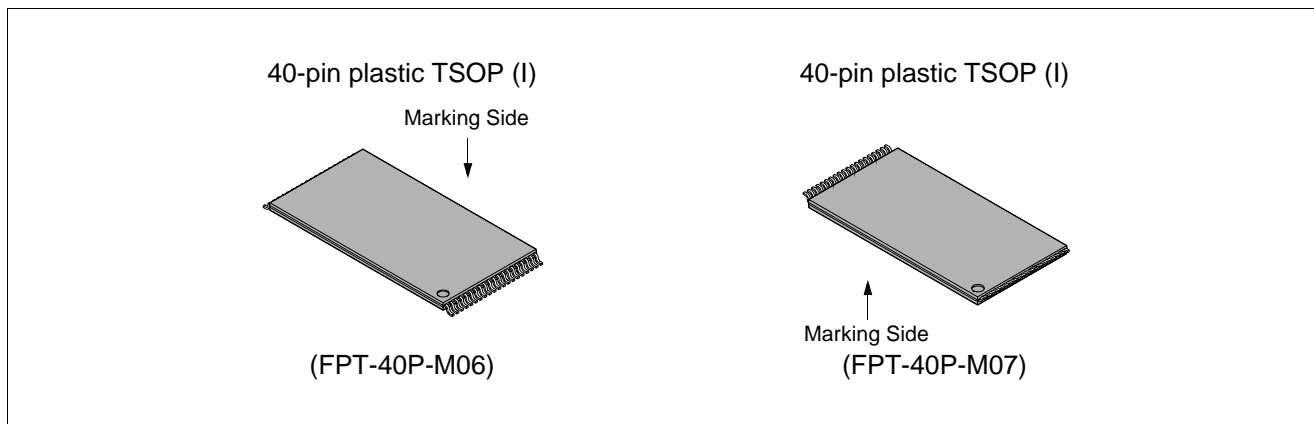

■ GENERAL DESCRIPTION

The MBM29F033C is a 32M-bit, 5.0 V-Only Flash memory organized as 4M bytes of 8 bits each. The 2M bytes of data is divided into 64 sectors of 64K bytes for flexible erase capability. The 8 bit of data will appear on DQ₀ to DQ₇. The MBM29F033C is offered in a 40-pin TSOP package. This device is designed to be programmed in-system with the standard system 5.0 V V_{CC} supply. A 12.0 V V_{PP} is not required for program or erase operations. The device can also be reprogrammed in standard EPROM programmers.

The standard MBM29F033C offers access times between 70 ns and 120 ns allowing operation of high-speed microprocessors without wait states. To eliminate bus contention the device has separate chip enable (\overline{CE}), write enable (\overline{WE}), and output enable (\overline{OE}) controls.

The MBM29F033C is command set compatible with JEDEC standard single-supply Flash standard. Commands are written to the command register using standard microprocessor write timings. Register contents serve as input to an internal state-machine which controls the erase and programming circuitry. Write cycles also internally latch addresses and data needed for the programming and erase operations. Reading data out of the device is similar to reading from 12.0 V Flash or EPROM devices.

The MBM29F033C is programmed by executing the program command sequence. This will invoke the Embedded Program™ Algorithm which is an internal algorithm that automatically times the program pulse widths and verifies proper cell margin. Each sector can be programmed and verified in less than 0.5 seconds. Erase is accomplished by executing the erase command sequence. This will invoke the Embedded Erase™ Algorithm which is an internal algorithm that automatically preprograms the array if it is not already programmed before executing the erase operation. During erase, the device automatically times the erase pulse widths and verifies proper cell margin.

This device also features a sector erase architecture. The sector erase mode allows for sectors of memory to be erased and reprogrammed without affecting other sectors. A sector is typically erased and verified within one second (if already completely preprogrammed). The MBM29F033C is erased when shipped from the factory.

The MBM29F033C device also features hardware sector group protection. This feature will disable both program and erase operations in any combination of eight sector groups of memory. *A sector group consists of four adjacent sectors grouped in the following pattern: sectors 0-3, 4-7, 8-11, 12-15, 16-19, 20-23, 24-27, 28-31, 32-35, 36-39, 40-43, 44-47, 48-51, 52-55, 56-59, and 60-63.*

Fujitsu has implemented an Erase Suspend feature that enables the user to put erase on hold for any period of time to read data from or program data to a non-busy sector. Thus, true background erase can be achieved.

The device features single 5.0 V power supply operation for both read and program functions. Internally generated and regulated voltages are provided for the program and erase operations. A low V_{CC} detector automatically inhibits write operations during power transitions. The end of program or erase is detected by $\overline{\text{Data}}$ Polling of DQ₇, or by the Toggle Bit I feature on DQ₆ or RY/ \overline{BY} output pin. Once the end of a program or erase cycle has been completed, the device automatically resets to the read mode.

The MBM29F033C also has a hardware $\overline{\text{RESET}}$ pin. When this pin is driven low, execution of any Embedded Program or Embedded Erase operations will be terminated. The internal state machine will then be reset into the read mode. The $\overline{\text{RESET}}$ pin may be tied to the system reset circuitry. Therefore, if a system reset occurs during the Embedded Program or Embedded Erase operation, the device will be automatically reset to a read mode. This will enable the system microprocessor to read the boot-up firmware from the Flash memory.

Fujitsu's Flash technology combines years of EPROM and E²PROM experience to produce the highest levels of quality, reliability, and cost effectiveness. The MBM29F033C memory electrically erases all bits within a sector simultaneously via Fowler-Nordheim tunneling. The bytes are programmed one byte at a time using the EPROM programming mechanism of hot electron injection.

MBM29F033C-70/-90/-12

■ FLEXIBLE SECTOR-ERASE ARCHITECTURE

- Sixty four 64K byte sectors
- 16 sector groups each of which consists of 4 adjacent sectors in the following pattern; sectors 0-3, 4-7, 8-11, 12-15, 16-19, 20-23, 24-27, 28-31, 32-35, 36-39, 40-43, 44-47, 48-51, 52-55, 56-59, and 60-63.
- Individual-sector or multiple-sector erase capability
- Sector group protection is user-definable

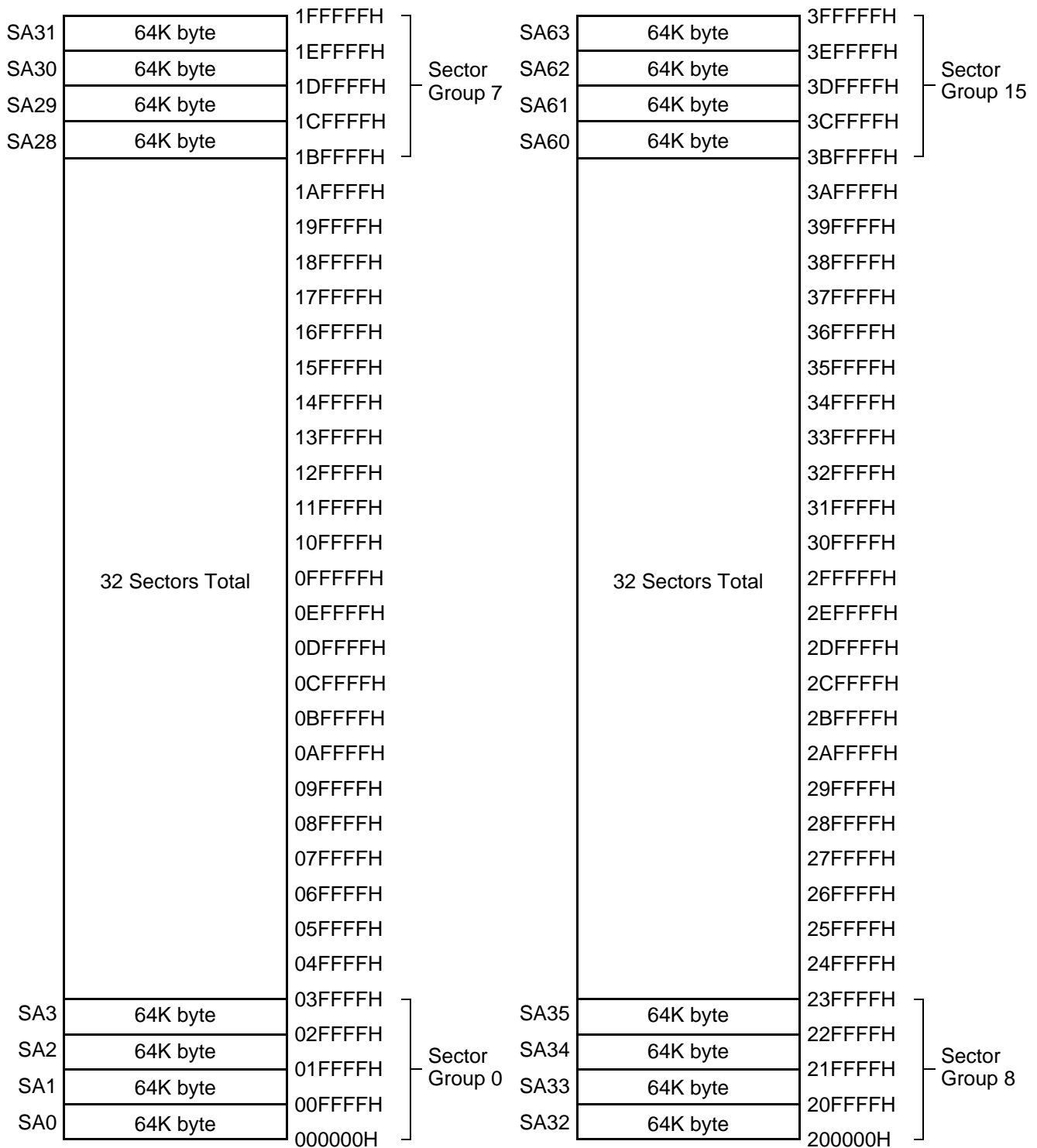

■ PRODUCT LINE UP

Part No.		MBM29F033C		
Ordering Part No.	$V_{CC} = 5.0\text{ V} \pm 5\%$	-70	—	—
	$V_{CC} = 5.0\text{ V} \pm 10\%$	—	-90	-12
Max. Address Access Time (ns)		70	90	120
Max. \overline{CE} Access Time (ns)		70	90	120
Max. \overline{OE} Access Time (ns)		40	40	50

■ BLOCK DIAGRAM

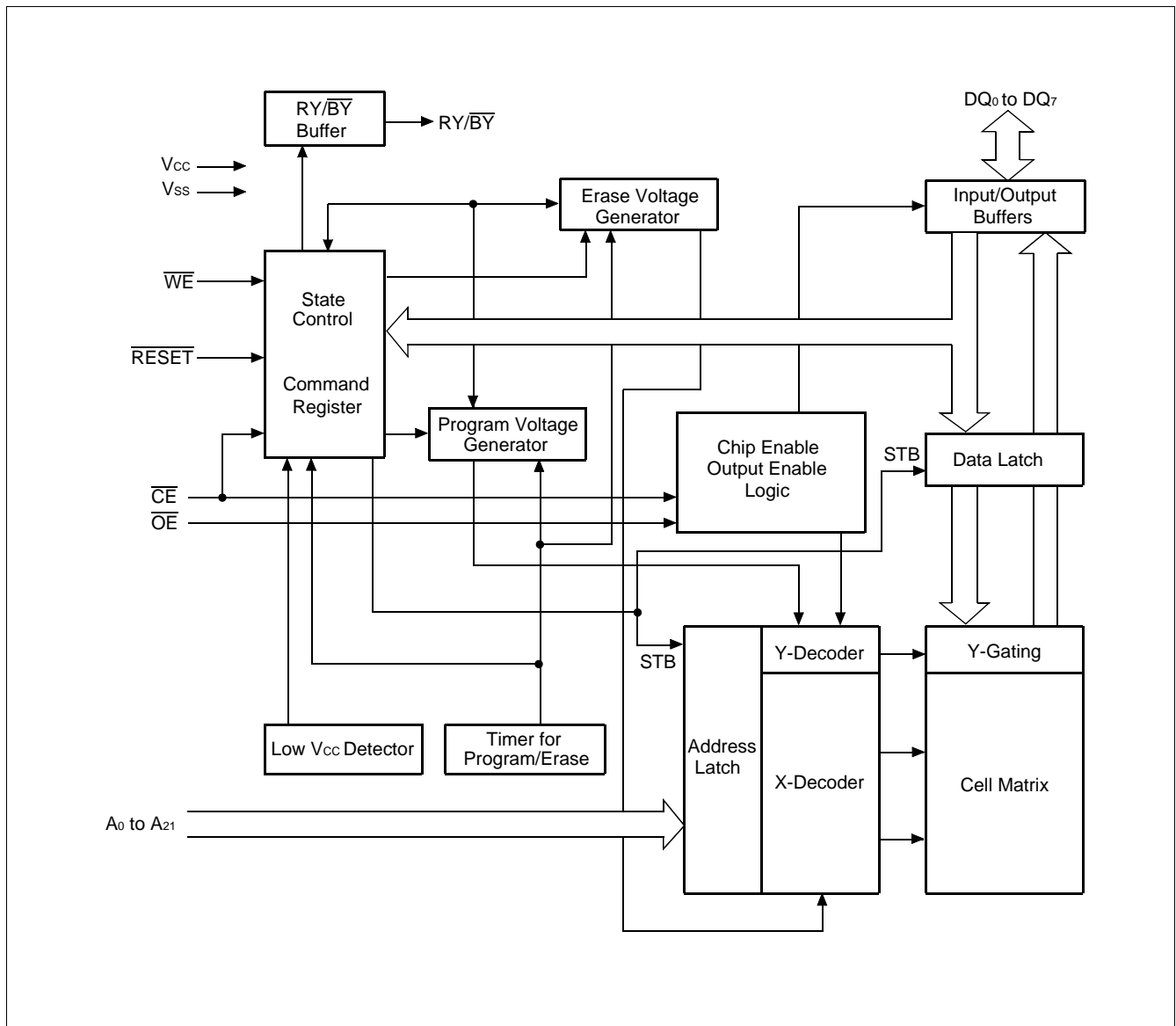

CONNECTION DIAGRAMS

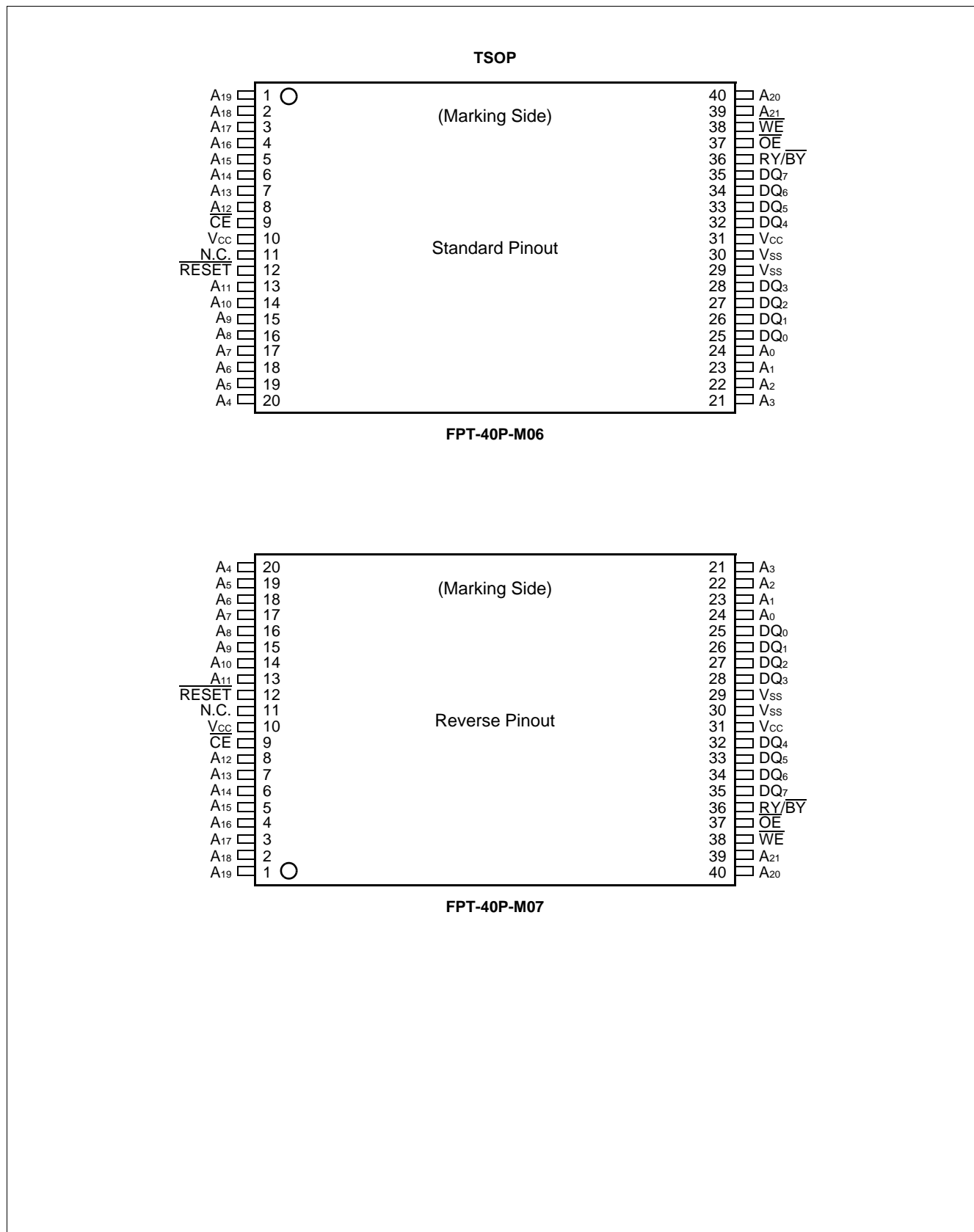

■ LOGIC SYMBOL

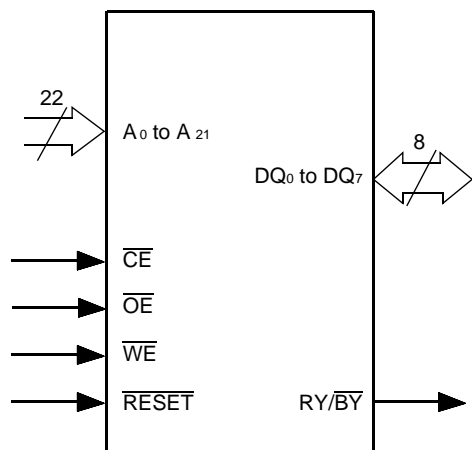

Table 1 MBM29F033C Pin Configuration

Pin	Function
A ₀ to A ₂₁	Address Inputs
DQ ₀ to DQ ₇	Data Inputs/Outputs
\overline{CE}	Chip Enable
\overline{OE}	Output Enable
\overline{WE}	Write Enable
RY/ \overline{BY}	Ready-Busy Output
\overline{RESET}	Hardware Reset Pin/Sector Protection Unlock
N.C.	No Internal Connection
V _{SS}	Device Ground
V _{CC}	Device Power Supply

Table 2 MBM29F033C User Bus Operations

Operation	\overline{CE}	\overline{OE}	\overline{WE}	A ₀	A ₁	A ₆	A ₉	DQ ₀ to DQ ₇	\overline{RESET}
Auto-Select Manufacturer Code (1)	L	L	H	L	L	L	V _{ID}	Code	H
Auto-Select Device Code (1)	L	L	H	H	L	L	V _{ID}	Code	H
Read (2)	L	L	H	A ₀	A ₁	A ₆	A ₉	D _{OUT}	H
Standby	H	X	X	X	X	X	X	HIGH-Z	H
Output Disable	L	H	H	X	X	X	X	HIGH-Z	H
Write	L	H	L	A ₀	A ₁	A ₆	A ₉	D _{IN}	H
Enable Sector Group Protection (3)	L	V _{ID}	$\overline{\square}$	X	X	X	V _{ID}	X	H
Verify Sector Group Protection (3)	L	L	H	L	H	L	V _{ID}	Code	H
Temporary Sector Group Unprotection	X	X	X	X	X	X	X	X	V _{ID}
Reset (Hardware)	X	X	X	X	X	X	X	HIGH-Z	L

Legend: L = V_{IL}, H = V_{IH}, X = V_{IL} or V_{IH}, $\overline{\square}$ = Pulse Input. See DC Characteristics for voltage levels.

Notes: 1. Manufacturer and device codes may also be accessed via a command register write sequence. Refer to Tables 6.

2. \overline{WE} can be V_{IL} if \overline{OE} is V_{IL}, \overline{OE} at V_{IH} initiates the write operations.

3. Refer to the section on Sector Group Protection.

MBM29F033C-70/-90/-12

■ ORDERING INFORMATION

Standard Products

Fujitsu standard products are available in several packages. The order number is formed by a combination of:

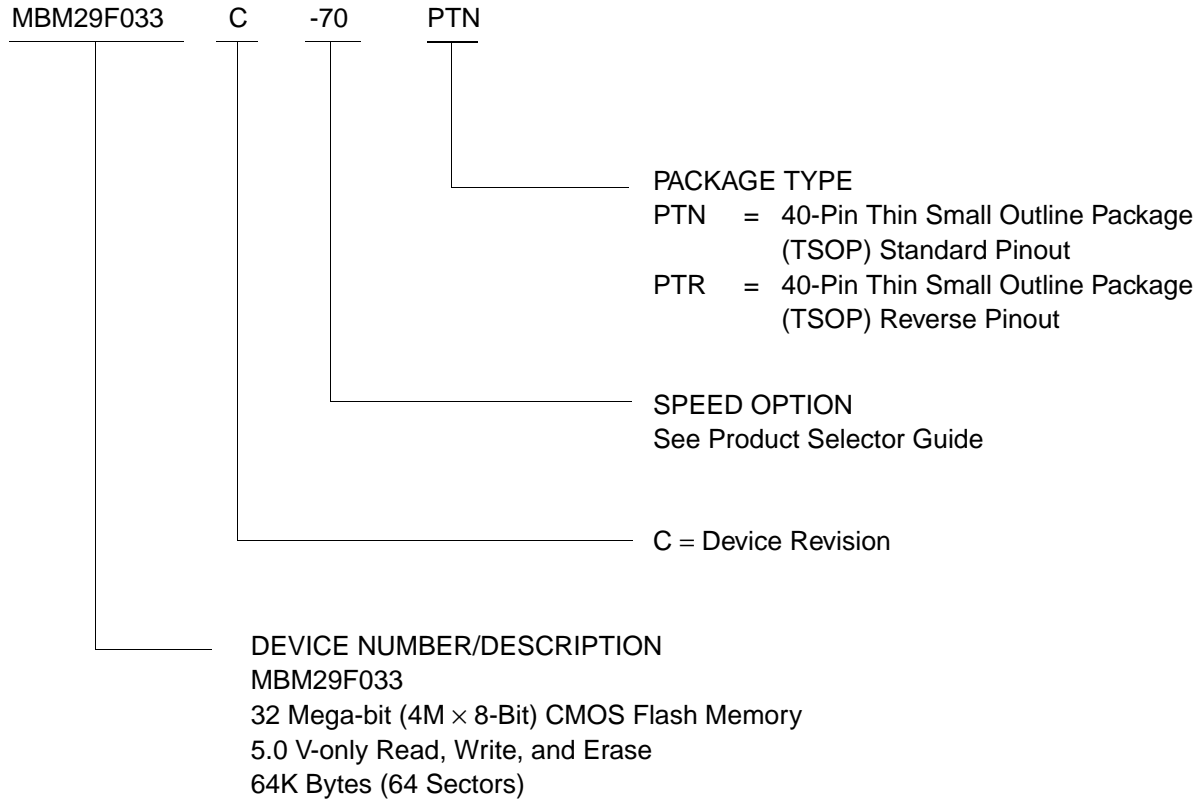

■ FUNCTIONAL DESCRIPTION

Read Mode

The MBM29F033C has two control functions which must be satisfied in order to obtain data at the outputs. \overline{CE} is the power control and should be used for a device selection. \overline{OE} is the output control and should be used to gate data to the output pins if a device is selected.

Address access time (t_{ACC}) is equal to the delay from stable addresses to valid output data. The chip enable access time (t_{CE}) is the delay from stable addresses and stable \overline{CE} to valid data at the output pins. The output enable access time is the delay from the falling edge of \overline{OE} to valid data at the output pins. (Assuming the addresses have been stable for at least $t_{ACC-tOE}$ time.)

Standby Mode

There are two ways to implement the standby mode on the MBM29F033C device, one using both the \overline{CE} and \overline{RESET} pins; the other via the \overline{RESET} pin only.

When using both pins, a CMOS standby mode is achieved with \overline{CE} and \overline{RESET} inputs both held at $V_{CC} \pm 0.3$ V. Under this condition the current consumed is less than 5 μ A. A TTL standby mode is achieved with \overline{CE} and \overline{RESET} pins held at V_{IH} . Under this condition the current is reduced to approximately 1 mA. During Embedded Algorithm operation, V_{CC} Active current (I_{CC2}) is required even $\overline{CE} = V_{IH}$. The device can be read with standard access time (t_{CE}) from either of these standby modes.

When using the \overline{RESET} pin only, a CMOS standby mode is achieved with \overline{RESET} input held at $V_{SS} \pm 0.3$ V ($\overline{CE} = \text{"H"}$ or "L"). Under this condition the current consumed is less than 5 μ A. A TTL standby mode is achieved with \overline{RESET} pin held at V_{IL} ($\overline{CE} = \text{"H"}$ or "L"). Under this condition the current required is reduced to approximately 1 mA. Once the \overline{RESET} pin is taken high, the device requires t_{RH} ns of wake up time before outputs are valid for read access.

In the standby mode the outputs are in the high impedance state, independent of the \overline{OE} input.

Output Disable

With the \overline{OE} input at a logic high level (V_{IH}), output from the device is disabled. This will cause the output pins to be in a high impedance state.

Autoselect

The autoselect mode allows the reading out of a binary code from the device and will identify its manufacturer and type. This mode is intended for use by programming equipment for the purpose of automatically matching the device to be programmed with its corresponding programming algorithm. This mode is functional over the entire temperature range of the device.

To activate this mode, the programming equipment must force V_{ID} (11.5 V to 12.5 V) on address pin A_9 . Two identifier bytes may then be sequenced from the device outputs by toggling address A_0 from V_{IL} to V_{IH} . All addresses are DON'T CARES except A_0 , A_1 , and A_6 . (See Table 3.)

The manufacturer and device codes may also be read via the command register, for instances when the MBM29F033C is erased or programmed in a system without access to high voltage on the A_9 pin. The command sequence is illustrated in Table 6. (Refer to Autoselect Command section.)

Byte 0 ($A_0 = V_{IL}$) represents the manufacturer's code (Fujitsu = 04H) and byte 1 ($A_0 = V_{IH}$) the device identifier code for MBM29F033C = D4H. These two bytes are given in the table 3. All identifiers for manufacturer and device will exhibit odd parity with DQ_7 defined as the parity bit. In order to read the proper device codes when executing the Autoselect, A_1 must be V_{IL} . (See Table 3.)

MBM29F033C-70/-90/-12

The Autoselect mode also facilitates the determination of sector group protection in the system. By performing a read operation at the address location XX02H with the higher order address bits A₁₈, A₁₉, A₂₀, and A₂₁ set to the desired sector group address, the device will return 01H for a protected sector group and 00H for a non-protected sector group.

Table 3 MBM29F033C Sector Protection Verify Autoselect Codes

Type	A ₁₈ to A ₂₁	A ₆	A ₁	A ₀	Code (HEX)	DQ ₇	DQ ₆	DQ ₅	DQ ₄	DQ ₃	DQ ₂	DQ ₁	DQ ₀
Manufacture's Code	X	V _{IL}	V _{IL}	V _{IL}	04H	0	0	0	0	0	1	0	0
Device Code	X	V _{IL}	V _{IL}	V _{IH}	D4H	1	1	0	1	0	1	0	0
Sector Group Protection	Sector Group Addresses	V _{IL}	V _{IH}	V _{IL}	01H*	0	0	0	0	0	0	0	1

* : Outputs 01H at protected sector addresses and outputs 00H at unprotected sector addresses.

Table 4 Sector Address Table

	A ₂₁	A ₂₀	A ₁₉	A ₁₈	A ₁₇	A ₁₆	Address Range
SA0	0	0	0	0	0	0	000000H to 00FFFFH
SA1	0	0	0	0	0	1	010000H to 01FFFFH
SA2	0	0	0	0	1	0	020000H to 02FFFFH
SA3	0	0	0	0	1	1	030000H to 03FFFFH
SA4	0	0	0	1	0	0	040000H to 04FFFFH
SA5	0	0	0	1	0	1	050000H to 05FFFFH
SA6	0	0	0	1	1	0	060000H to 06FFFFH
SA7	0	0	0	1	1	1	070000H to 07FFFFH
SA8	0	0	1	0	0	0	080000H to 08FFFFH
SA9	0	0	1	0	0	1	090000H to 09FFFFH
SA10	0	0	1	0	1	0	0A0000H to 0AFFFFH
SA11	0	0	1	0	1	1	0B0000H to 0BFFFFH
SA12	0	0	1	1	0	0	0C0000H to 0CFFFFH
SA13	0	0	1	1	0	1	0D0000H to 0DFFFFH
SA14	0	0	1	1	1	0	0E0000H to 0EFFFFH
SA15	0	0	1	1	1	1	0F0000H to 0FFFFFFH
SA16	0	1	0	0	0	0	100000H to 10FFFFH
SA17	0	1	0	0	0	1	110000H to 11FFFFH
SA18	0	1	0	0	1	0	120000H to 12FFFFH
SA19	0	1	0	0	1	1	130000H to 13FFFFH
SA20	0	1	0	1	0	0	140000H to 14FFFFH
SA21	0	1	0	1	0	1	150000H to 15FFFFH
SA22	0	1	0	1	1	0	160000H to 16FFFFH
SA23	0	1	0	1	1	1	170000H to 17FFFFH
SA24	0	1	1	0	0	0	180000H to 18FFFFH
SA25	0	1	1	0	0	1	190000H to 19FFFFH
SA26	0	1	1	0	1	0	1A0000H to 1AFFFFH
SA27	0	1	1	0	1	1	1B0000H to 1BFFFFH
SA28	0	1	1	1	0	0	1C0000H to 1CFFFFH
SA29	0	1	1	1	0	1	1D0000H to 1DFFFFH
SA30	0	1	1	1	1	0	1E0000H to 1EFFFFH
SA31	0	1	1	1	1	1	1F0000H to 1FFFFFFH

(Continued)

MBM29F033C-70/-90/-12

(Continued)

	A ₂₁	A ₂₀	A ₁₉	A ₁₈	A ₁₇	A ₁₆	Address Range
SA32	1	0	0	0	0	0	200000H to 20FFFFH
SA33	1	0	0	0	0	1	210000H to 21FFFFH
SA34	1	0	0	0	1	0	220000H to 22FFFFH
SA35	1	0	0	0	1	1	230000H to 23FFFFH
SA36	1	0	0	1	0	0	240000H to 24FFFFH
SA37	1	0	0	1	0	1	250000H to 25FFFFH
SA38	1	0	0	1	1	0	260000H to 26FFFFH
SA39	1	0	0	1	1	1	270000H to 27FFFFH
SA40	1	0	1	0	0	0	280000H to 28FFFFH
SA41	1	0	1	0	0	1	290000H to 29FFFFH
SA42	1	0	1	0	1	0	2A0000H to 2AFFFFH
SA43	1	0	1	0	1	1	2B0000H to 2BFFFFH
SA44	1	0	1	1	0	0	2C0000H to 2CFFFFH
SA45	1	0	1	1	0	1	2D0000H to 2DFFFFH
SA46	1	0	1	1	1	0	2E0000H to 2EFFFFH
SA47	1	0	1	1	1	1	2F0000H to 2FFFFFFH
SA48	1	1	0	0	0	0	300000H to 30FFFFH
SA49	1	1	0	0	0	1	310000H to 31FFFFH
SA50	1	1	0	0	1	0	320000H to 32FFFFH
SA51	1	1	0	0	1	1	330000H to 33FFFFH
SA52	1	1	0	1	0	0	340000H to 34FFFFH
SA53	1	1	0	1	0	1	350000H to 35FFFFH
SA54	1	1	0	1	1	0	360000H to 36FFFFH
SA55	1	1	0	1	1	1	370000H to 37FFFFH
SA56	1	1	1	0	0	0	380000H to 38FFFFH
SA57	1	1	1	0	0	1	390000H to 39FFFFH
SA58	1	1	1	0	1	0	3A0000H to 3AFFFFH
SA59	1	1	1	0	1	1	3B0000H to 3BFFFFH
SA60	1	1	1	1	0	0	3C0000H to 3CFFFFH
SA61	1	1	1	1	0	1	3D0000H to 3DFFFFH
SA62	1	1	1	1	1	0	3E0000H to 3EFFFFH
SA63	1	1	1	1	1	1	3F0000H to 3FFFFFFH

Table 5 Sector Group Addresses

	A ₂₀	A ₂₀	A ₁₉	A ₁₈	Sectors
SGA0	0	0	0	0	SA0 to SA3
SGA1	0	0	0	1	SA4 to SA7
SGA2	0	0	1	0	SA8 to SA11
SGA3	0	0	1	1	SA12 to SA15
SGA4	0	1	0	0	SA16 to SA19
SGA5	0	1	0	1	SA20 to SA23
SGA6	0	1	1	0	SA24 to SA27
SGA7	0	1	1	1	SA28 to SA31
SGA8	1	0	0	0	SA32 to SA35
SGA9	1	0	0	1	SA36 to SA39
SGA10	1	0	1	0	SA40 to SA43
SGA11	1	0	1	1	SA44 to SA47
SGA12	1	1	0	0	SA48 to SA51
SGA13	1	1	0	1	SA52 to SA55
SGA14	1	1	1	0	SA56 to SA59
SGA15	1	1	1	1	SA60 to SA63

Write

Device erasure and programming are accomplished via the command register. The contents of the register serve as inputs to the internal state machine. The state machine outputs dictate the function of the device.

The command register itself does not occupy any addressable memory location. The register is a latch used to store the commands, along with the address and data information needed to execute the command. The command register is written by bringing \overline{WE} to V_{IL} , while \overline{CE} is at V_{IL} and \overline{OE} is at V_{IH} . Addresses are latched on the falling edge of \overline{WE} or \overline{CE} , whichever happens later; while data is latched on the rising edge of \overline{WE} or \overline{CE} , whichever happens first. Standard microprocessor write timings are used.

Refer to AC Write Characteristics and the Erase/Programming Waveforms for specific timing parameters.

Sector Group Protection

The MBM29F033C features hardware sector group protection. This feature will disable both program and erase operations in any combination of sixteen sector groups of memory. Each sector group consists of four adjacent sectors grouped in the following pattern: sectors 0-3, 4-7, 8-11, 12-15, 16-19, 20-23, 24-27, 28-31, 32-35, 36-39, 40-43, 44-47, 48-51, 52-55, 56-59, and 60-63 (see Table 5). The sector group protection feature is enabled using programming equipment at the user's site. The device is shipped with all sector groups unprotected.

To activate this mode, the programming equipment must force V_{ID} on address pin A_9 and control pin \overline{OE} , (suggest $V_{ID} = 11.5\text{ V}$), $\overline{CE} = V_{IL}$. The sector addresses (A_{21} , A_{20} , A_{19} , and A_{18}) should be set to the sector to be protected. Tables 4 and 5 define the sector address for each of the sixty four (64) individual sectors, and the sector group address for each of the sixteen (16) individual group sectors. Programming of the protection circuitry begins on the falling edge of the \overline{WE} pulse and is terminated with the rising edge of the same. Sector addresses must be held constant during the \overline{WE} pulse. Refer to figures 14 and 21 for sector protection waveforms and algorithm.

To verify programming of the protection circuitry, the programming equipment must force V_{ID} on address pin A_9 with \overline{CE} and \overline{OE} at V_{IL} and \overline{WE} at V_{IH} . Scanning the sector addresses (A_{21} , A_{20} , A_{19} , and A_{18}) while (A_6 , A_1 , A_0) = (0, 1, 0) will produce a logical "1" code at device output DQ_0 for a protected sector. Otherwise the device will produce 00H for unprotected sector. In this mode, the lower order addresses, except for A_0 , A_1 , and A_6 are don't care. Address locations with $A_1 = V_{IL}$ are reserved for Autoselect manufacturer and device codes.

It is also possible to determine if a sector group is protected in the system by writing an Autoselect command. Performing a read operation at the address location XX02H, where the higher order addresses (A_{21} , A_{20} , A_{19} , and A_{18}) are the desired sector group address will produce a logical "1" at DQ_0 for a protected sector group. See Table 3 for Autoselect codes.

Temporary Sector Group Unprotection

This feature allows temporary unprotection of previously protected sector groups of the MBM29F033C device in order to change data. The Sector Group Unprotection mode is activated by setting the $\overline{\text{RESET}}$ pin to high voltage (12 V). During this mode, formerly protected sector groups can be programmed or erased by selecting the sector group addresses. Once the 12 V is taken away from the $\overline{\text{RESET}}$ pin, all the previously protected sector groups will be protected again. Refer to Figures 13 and 20.

Table 6 MBM29F033C Command Definitions

Command Sequence	Bus Write Cycle's Req'd	First Bus Write Cycle		Second Bus Write Cycle		Third Bus Write Cycle		Fourth Bus Read/Write Cycle		Fifth Bus Write Cycle		Sixth Bus Write Cycle	
		Addr.	Data	Addr.	Data	Addr.	Data	Addr.	Data	Addr.	Data	Addr.	Data
Read/Reset*	1	XXXH	F0H	—	—	—	—	—	—	—	—	—	—
Reset/Read*	3	XXXH	AAH	XXXH	55H	XXXH	F0H	RA	RD	—	—	—	—
Autoselect	3	XXXH	AAH	XXXH	55H	XXXH	90H	—	—	—	—	—	—
Byte Program	4	XXXH	AAH	XXXH	55H	XXXH	A0H	PA	PD	—	—	—	—
Chip Erase	6	XXXH	AAH	XXXH	55H	XXXH	80H	XXXH	AAH	XXXH	55H	XXXH	10H
Sector Erase	6	XXXH	AAH	XXXH	55H	XXXH	80H	XXXH	AAH	XXXH	55H	SA	30H
Sector Erase Suspend	1	Erase can be suspended during sector erase with Addr ("H" or "L"). Data (B0H)											
Sector Erase Resume	1	Erase can be resumed after suspend with Addr ("H" or "L"). Data (30H)											

- Notes:**
1. Address bits A₁₈ to A₂₁ = X = "H" or "L" for all address commands except or Program Address (PA) and Sector Address (SA).
 2. Bus operations are defined in Table 2.
 3. RA = Address of the memory location to be read.
PA = Address of the memory location to be programmed. Addresses are latched on the falling edge of the $\overline{\text{WE}}$ pulse.
SA = Address of the sector to be erased. The combination of A₂₁, A₂₀, A₁₉, A₁₈, A₁₇, and A₁₆ will uniquely select any sector.
 4. RD = Data read from location RA during read operation.
PD = Data to be programmed at location PA. Data is latched on the rising edge of $\overline{\text{WE}}$.
 5. Read and Byte program functions to non-erasing sectors are allowed in the Erase Suspend mode.
 6. X = "H" or "L"

* : Either of the two reset commands will reset the device.

Command Definitions

Device operations are selected by writing specific address and data sequences into the command register. Writing incorrect address and data values or writing them in the improper sequence will reset the device to the read mode. Table 6 defines the valid register command sequences. Note that the Erase Suspend (B0H) and Erase Resume (30H) commands are valid only while the Sector Erase operation is in progress. Moreover, both Read/Reset commands are functionally equivalent, resetting the device to the read mode.

Read/Reset Command

The read or reset operation is initiated by writing the read/reset command sequence into the command register. Microprocessor read cycles retrieve array data from the memory. The device remains enabled for reads until the command register contents are altered.

The device will automatically power-up in the read/reset state. In this case, a command sequence is not required to read data. Standard microprocessor read cycles will retrieve array data. This default value ensures that no spurious alteration of the memory content occurs during the power transition. Refer to the AC Read Characteristics and Waveforms for the specific timing parameters.

Autoselect Command

Flash memories are intended for use in applications where the local CPU alters memory contents. As such, manufacture and device codes must be accessible while the device resides in the target system. PROM programmers typically access the signature codes by raising A_9 to a high voltage. However, multiplexing high voltage onto the address lines is not generally desirable system design practice.

The device contains an autoselect command operation to supplement traditional PROM programming methodology. The operation is initiated by writing the autoselect command sequence into the command register. Following the command write, a read cycle from address XX00H retrieves the manufacture code of 04H. A read cycle from address XX01H returns the device code D4H. (See Table 3.)

All manufacturer and device codes will exhibit odd parity with the DQ_7 defined as the parity bit.

Sector state (protection or unprotection) will be informed by address XX02H.

Scanning the sector group addresses (A_{18} , A_{19} , A_{20} , and A_{21}) while (A_6 , A_1 , A_0) = (0, 1, 0) will produce a logical "1" at device output DQ_0 for a protected sector group.

To terminate the operation, it is necessary to write the read/reset command sequence into the register and also to write the autoselect command during the operation, execute it after writing read/reset command sequence.

Byte Programming

The device is programmed on a byte-by-byte basis. Programming is a four bus cycle operation. There are two "unlock" write cycles. These are followed by the program set-up command and data write cycles. Addresses are latched on the falling edge of \overline{CE} or \overline{WE} , whichever happens later and the data is latched on the rising edge of \overline{CE} or \overline{WE} , whichever happens first. The rising edge of \overline{CE} or \overline{WE} (whichever happens first) begins programming. Upon executing the Embedded Program™ Algorithm command sequence, the system is *not* required to provide further controls or timings. The device will automatically provide adequate internally generated program pulses and verify the programmed cell margin.

This automatic programming operation is completed when the data on DQ_7 is equivalent to data written to this bit at which time the device returns to the read mode and addresses are no longer latched. (See Table 7, Hardware Sequence Flags.) Therefore, the device requires that a valid address to the device be supplied by the system at this particular instance of time. \overline{Data} Polling must be performed at the memory location which is being programmed.

Any commands written to the chip during this period will be ignored. If a hardware reset occurs during the programming operation, it is impossible to guarantee the data are being written.

Programming is allowed in any sequence and across sector boundaries. Beware that a data "0" cannot be programmed back to a "1". Attempting to do so may either hang up the device or result in an apparent success according to the data polling algorithm but a read from reset/read mode will show that the data is still "0". Only erase operations can convert "0"s to "1"s.

Figure 15 illustrates the Embedded Programming Algorithm using typical command strings and bus operations.

Chip Erase

Chip erase is a six bus cycle operation. There are two “unlock” write cycles. These are followed by writing the “set-up” command. Two more “unlock” write cycles are then followed by the chip erase command.

Chip erase does not require the user to program the device prior to erase. Upon executing the Embedded Erase™ Algorithm command sequence the device will automatically program and verify the entire memory for an all zero data pattern prior to electrical erase. The system is not required to provide any controls or timings during these operations.

The automatic erase begins on the rising edge of the last \overline{WE} pulse in the command sequence and terminates when the data on DQ₇ is “1” (See Write Operation Status section.) at which time the device returns to read the mode.

Figure 16 illustrates the Embedded Erase™ Algorithm using typical command strings and bus operations.

Sector Erase

Sector erase is a six bus cycle operation. There are two “unlock” write cycles. These are followed by writing the “set-up” command. Two more “unlock” write cycles are then followed by the sector erase command. The sector address (any address location within the desired sector) is latched on the falling edge of \overline{WE} , while the command (Data = 30H) is latched on the rising edge of \overline{WE} . After time-out of 50 μ s from the rising edge of the last sector erase command, the sector erase operation will begin.

Multiple sectors may be erased concurrently by writing the six bus cycle operations on Table 6. This sequence is followed with writes of the Sector Erase command to addresses in other sectors desired to be concurrently erased. The time between writes must be less than 50 μ s otherwise that command will not be accepted and erasure will start. It is recommended that processor interrupts be disabled during this time to guarantee this condition. The interrupts can be re-enabled after the last Sector Erase command is written. A time-out of 50 μ s from the rising edge of the last \overline{WE} will initiate the execution of the Sector Erase command(s). If another falling edge of the \overline{WE} occurs within the 50 μ s time-out window the timer is reset. (Monitor DQ₃ to determine if the sector erase timer window is still open, see section DQ₃, Sector Erase Timer.) Any command other than Sector Erase or Erase Suspend during this time-out period will reset the device to the read mode, ignoring the previous command string. Resetting the device once execution has begun will corrupt the data in that sector. In that case, restart the erase on those sectors and allow them to complete. (Refer to the Write Operation Status section for DQ₃, Sector Erase Timer operation.) Loading the sector erase buffer may be done in any sequence and with any number of sectors (0 to 63).

Sector erase does not require the user to program the device prior to erase. The device automatically programs all memory locations in the sector(s) to be erased prior to electrical erase. When erasing a sector or sectors the remaining unselected sectors are not affected. The system is not required to provide any controls or timings during these operations.

The automatic sector erase begins after the 50 μ s time out from the rising edge of the \overline{WE} pulse for the last sector erase command pulse and terminates when the data on DQ₇ is “1” (See Write Operation Status section.) at which time the device returns to the read mode. \overline{Data} polling must be performed at an address within any of the sectors being erased.

Figure 16 illustrates the Embedded Erase™ Algorithm using typical command strings and bus operations.

Erase Suspend

The Erase Suspend command allows the user to interrupt a Sector Erase operation and then perform data reads from or programs to a sector not being erased. This command is applicable ONLY during the Sector Erase operation which includes the time-out period for sector erase. The Erase Suspend command will be ignored if written during the Chip Erase operation or Embedded Program™ Algorithm. Writing the Erase Suspend command during the Sector Erase time-out results in immediate termination of the time-out period and suspension of the erase operation.

Any other command written during the Erase Suspend mode will be ignored except the Erase Resume command. Writing the Erase Resume command resumes the erase operation. The addresses are “don't-cares” when writing the Erase Suspend or Erase Resume command.

When the Erase Suspend command is written during the Sector Erase operation, the device will take a maximum of 15 ms to suspend the erase operation. When the device has entered the erase-suspended mode, the RY/ $\overline{\text{BY}}$ output pin and the DQ₇ bit will be at logic “1”, and DQ₆ will stop toggling. The user must use the address of the erasing sector for reading DQ₆ and DQ₇ to determine if the erase operation has been suspended. Further writes of the Erase Suspend command are ignored.

When the erase operation has been suspended, the device defaults to the erase-suspend-read mode. Reading data in this mode is the same as reading from the standard read mode except that the data must be read from sectors that have not been erase-suspended. Successively reading from the erase-suspended sector while the device is in the erase-suspend-read mode will cause DQ₂ to toggle. (See the section on DQ₂.)

After entering the erase-suspend-read mode, the user can program the device by writing the appropriate command sequence for Byte Program. This program mode is known as the erase-suspend-program mode. Again, programming in this mode is the same as programming in the regular Byte Program mode except that the data must be programmed to sectors that are not erase-suspended. Successively reading from the erase-suspended sector while the device is in the erase-suspend-program mode will cause DQ₂ to toggle. The end of the erase-suspended program operation is detected by the RY/ $\overline{\text{BY}}$ output pin, $\overline{\text{Data}}$ polling of DQ₇, or by the Toggle Bit I (DQ₆) which is the same as the regular Byte Program operation. Note that DQ₇ must be read from the byte program address while DQ₆ can be read from any address.

To resume the operation of Sector Erase, the Resume command (30H) should be written. Any further writes of the Resume command at this point will be ignored. Another Erase Suspend command can be written after the chip has resumed erasing.

Write Operation Status

Table 7 Hardware Sequence Flags

Status		DQ ₇	DQ ₆	DQ ₅	DQ ₃	DQ ₂	
In progress	Embedded Program™ Algorithm	\overline{DQ}_7	Toggle	0	0	1	
	Embedded Erase™ Algorithm	0	Toggle	0	1	Toggle	
	Erase Suspended Mode	Erase Suspend Read (Erase Suspended Sector)	1	1	0	0	Toggle
		Erase Suspend Read (Non-Erase Suspended Sector)	Data	Data	Data	Data	Data
		Erase Suspend Program (Non-Erase Suspended Sector)	\overline{DQ}_7	Toggle (Note 1)	0	0	1 (Note 2)
Exceeded Time Limits	Embedded Program™ Algorithm	\overline{DQ}_7	Toggle	1	0	1	
	Embedded Erase™ Algorithm	0	Toggle	1	1	N/A	
	Erase Suspended Mode	Erase Suspend Program (Non-Erase Suspended Sector)	\overline{DQ}_7	Toggle	1	0	N/A

- Notes:**
1. Performing successive read operations from any address will cause DQ₆ to toggle.
 2. Reading the byte address being programmed while in the erase-suspend program mode will indicate logic “1” at the DQ₂ bit. However, successive reads from the erase-suspended sector will cause DQ₂ to toggle.
 3. DQ₀ and DQ₁ are reserved pins for future use.
 4. DQ₄ is Fujitsu internal use only.

DQ₇

Data Polling

The MBM29F033C device features $\overline{\text{Data}}$ Polling as a method to indicate to the host that the embedded algorithms are in progress or completed. During the Embedded Program™ Algorithm, an attempt to read the device will produce the complement of the data last written to DQ₇. Upon completion of the Embedded Program™ Algorithm, an attempt to read the device will produce the true data last written to DQ₇. During the Embedded Erase™ Algorithm, an attempt to read the device will produce a “0” at the DQ₇ output. Upon completion of the Embedded Erase™ Algorithm an attempt to read the device will produce a “1” at the DQ₇ output. The flowchart for $\overline{\text{Data}}$ Polling (DQ₇) is shown in Figure 17.

$\overline{\text{Data}}$ polling will also flag the entry into Erase Suspend. DQ₇ will switch “0” to “1” at the start of the Erase Suspend mode. Please note that the address of an erasing sector must be applied in order to observe DQ₇ in the Erase Suspend Mode.

During Program in Erase Suspend, $\overline{\text{Data}}$ polling will perform the same as in regular program execution outside of the suspend mode.

For chip erase, the $\overline{\text{Data}}$ Polling is valid after the rising edge of the sixth $\overline{\text{WE}}$ pulse in the six write pulse sequence. For sector erase, the $\overline{\text{Data}}$ Polling is valid after the last rising edge of the sector erase $\overline{\text{WE}}$ pulse. $\overline{\text{Data}}$ Polling must be performed at sector address within any of the sectors being erased and not a sector that is within a protected sector group. Otherwise, the status may not be valid.

Just prior to the completion of Embedded Algorithm operation DQ₇ may change asynchronously while the output enable (\overline{OE}) is asserted low. This means that the device is driving status information on DQ₇ at one instant of time and then that byte's valid data at the next instant of time. Depending on when the system samples the DQ₇ output, it may read the status or valid data. Even if the device has completed the Embedded Algorithm operations and DQ₇ has a valid data, the data outputs on DQ₀ to DQ₆ may be still invalid. The valid data on DQ₀ to DQ₇ will be read on the successive read attempts.

The \overline{Data} Polling feature is only active during the Embedded Programming Algorithm, Embedded Erase Algorithm, Erase Suspend, erase-suspend-program mode, or sector erase time-out. (See Table 7.)

See Figure 8 for the \overline{Data} Polling timing specifications and diagrams.

DQ₆

Toggle Bit I

The MBM29F033C also features the "Toggle Bit I" as a method to indicate to the host system that the embedded algorithms are in progress or completed.

During an Embedded Program or Erase Algorithm cycle, successive attempts to read (\overline{OE} toggling) data from the device at any address will result in DQ₆ toggling between one and zero. Once the Embedded Program or Erase Algorithm cycle is completed, DQ₆ will stop toggling and valid data will be read on *the next* successive attempts. During programming, the Toggle Bit I is valid after the rising edge of the fourth \overline{WE} pulse in the four write pulse sequence. For chip erase, the Toggle Bit I is valid after the rising edge of the sixth \overline{WE} pulse in the six write pulse sequence. For Sector Erase, the Toggle Bit I is valid after the last rising edge of the sector erase \overline{WE} pulse. The Toggle Bit I is active during the sector erase time out.

Either \overline{CE} or \overline{OE} toggling will cause the DQ₆ to toggle. In addition, an Erase Suspend/Resume command will cause DQ₆ to toggle. See Figure 9 for the Toggle Bit I timing specifications and diagrams.

DQ₅

Exceeded Timing Limits

DQ₅ will indicate if the program or erase time has exceeded the specified limits (internal pulse count). Under these conditions DQ₅ will produce a "1". This is a failure condition which indicates that the program or erase cycle was not successfully completed. \overline{Data} Polling is the only operating function of the device under this condition. The \overline{CE} circuit will partially power down the device under these conditions. The \overline{OE} and \overline{WE} pins will control the output disable functions as described in Table 2.

The DQ₅ failure condition may also appear if a user tries to program a 1 to a location that is previously programmed to 0. In this case the device locks out and never completes the Embedded Program™ Algorithm. Hence, the system never reads a valid data on DQ₇ bit and DQ₆ never stops toggling. Once the device has exceeded timing limits, the DQ₅ bit will indicate a "1." Please note that this is not a device failure condition since the device was incorrectly used. If this occurs, reset the device.

DQ₃

Sector Erase Timer

After the completion of the initial sector erase command sequence the sector erase time-out will begin. DQ₃ will remain low until the time-out is complete. \overline{Data} Polling and Toggle Bit I are valid after the initial sector erase command sequence.

If \overline{Data} Polling or the Toggle Bit I indicates the device has been written with a valid erase command, DQ₃ may be used to determine if the sector erase timer window is still open. If DQ₃ is high ("1") the internally controlled erase cycle has begun; attempts to write subsequent commands (other than Erase Suspend) to the device will be ignored until the erase operation is completed as indicated by \overline{Data} Polling or Toggle Bit I. If DQ₃ is low ("0"),

the device will accept additional sector erase commands. To insure the command has been accepted, the system software should check the status of DQ₃ prior to and following each subsequent sector erase command. If DQ₃ were high on the second status check, the command may not have been accepted.

Refer to Table 7: Hardware Sequence Flags

DQ₂

Toggle Bit II

This toggle bit, along with DQ₆, can be used to determine whether the device is in the Embedded Erase™ Algorithm or in Erase Suspend.

Successive reads from the erasing sector will cause DQ₂ to toggle during the Embedded Erase™ Algorithm. If the device is in the erase-suspended-read mode, successive reads from the erase-suspended sector will cause DQ₂ to toggle. When the device is in the erase-suspended-program mode, successive reads from the byte address of the non-erase suspended sector will indicate a logic “1” at the DQ₂ bit.

DQ₆ is different from DQ₂ in that DQ₆ toggles only when the standard program or Erase, or Erase Suspend Program operation is in progress. The behavior of these two status bits, along with that of DQ₇, is summarized as follows:

Mode	DQ ₇	DQ ₆	DQ ₂
Program	$\overline{DQ_7}$	toggles	1
Erase	0	toggles	toggles
Erase Suspend Read (1) (Erase-Suspended Sector)	1	1	toggles
Erase Suspend Program	$\overline{DQ_7}$ (2)	toggles	1 (2)

- Notes:** 1. These status flags apply when outputs are read from a sector that has been erase-suspended.
2. These status flags apply when outputs are read from the byte address of the non-erase suspended sector.

For example, DQ₂ and DQ₆ can be used together to determine the erase-suspend-read mode. (DQ₂ toggles while DQ₆ does not.) See also Table 7 and Figure 14.

Furthermore, DQ₂ can also be used to determine which sector is being erased. When the device is in the erase mode, DQ₂ toggles if this bit is read from the erasing sector.

RY/ \overline{BY}

Ready/Busy

The MBM29F033C provides a RY/ \overline{BY} open-drain output pin as a way to indicate to the host system that the Embedded Algorithms are either in progress or has been completed. If the output is low, the device is busy with either a program or erase operation. If the output is high, the device is ready to accept any read/write or erase operation. When the RY/ \overline{BY} pin is low, the device will not accept any additional program or erase commands with the exception of the Erase Suspend command. If the MBM29F033C is placed in an Erase Suspend mode, the RY/ \overline{BY} output will be high, by means of connecting with a pull-up resistor to V_{CC}.

During programming, the RY/ \overline{BY} pin is driven low after the rising edge of the fourth \overline{WE} pulse. During an erase operation, the RY/ \overline{BY} pin is driven low after the rising edge of the sixth \overline{WE} pulse. The RY/ \overline{BY} pin will indicate a busy condition during \overline{RESET} pulse. Refer to Figure 10 for a detailed timing diagram. The RY/ \overline{BY} pin is pulled high in standby mode.

Since this is an open-drain output, several RY/ \overline{BY} pins can be tied together in parallel with a pull-up resistor to V_{CC}.

$\overline{\text{RESET}}$

Hardware Reset

The MBM29F033C device may be reset by driving the $\overline{\text{RESET}}$ pin to V_{IL} . The $\overline{\text{RESET}}$ pin must be kept low (V_{IL}) for at least 500 ns. Any operation in progress will be terminated and the internal state machine will be reset to the read mode 20 ms after the $\overline{\text{RESET}}$ pin is driven low. If a hardware reset occurs during a program operation, the data at that particular location will be indeterminate.

When the $\overline{\text{RESET}}$ pin is low and the internal reset is complete, the device goes to standby mode and cannot be accessed. Also, note that all the data output pins are tristated for the duration of the $\overline{\text{RESET}}$ pulse. Once the $\overline{\text{RESET}}$ pin is taken high, the device requires t_{RH} ns of wake up time until outputs are valid for read access.

The $\overline{\text{RESET}}$ pin may be tied to the system reset input. Therefore, if a system reset occurs during the Embedded Program or Erase Algorithm, the device will be automatically reset to read mode and this will enable the system's microprocessor to read the boot-up firmware from the Flash memory.

Data Protection

The MBM29F033C is designed to offer protection against accidental erasure or programming caused by spurious system level signals that may exist during power transitions. During power up the device automatically resets the internal state machine in the Read mode. Also, with its control register architecture, alteration of the memory contents only occurs after successful completions of specific multi-bus cycle command sequences.

The device also incorporates several features to prevent inadvertent write cycles resulting from V_{CC} power-up and power-down transitions or system noise.

Low V_{CC} Write Inhibit

To avoid initiation of a write cycle during V_{CC} power-up and power-down, a write cycle is locked out for V_{CC} less than V_{LKO} (typically 3.7 V). If $V_{CC} < V_{LKO}$, the command register is disabled and all internal program/erase circuits are disabled. Under this condition the device will reset to the read mode. Subsequent writes will be ignored until the V_{CC} level is greater than V_{LKO} . It is the users responsibility to ensure that the control pins are logically correct to prevent unintentional writes when V_{CC} is above 3.2 V.

Write Pulse “Glitch” Protection

Noise pulses of less than 5 ns (typical) on $\overline{\text{OE}}$, $\overline{\text{CE}}$, or $\overline{\text{WE}}$ will not initiate a write cycle.

Logical Inhibit

Writing is inhibited by holding any one of $\overline{\text{OE}} = V_{IL}$, $\overline{\text{CE}} = V_{IH}$ or $\overline{\text{WE}} = V_{IH}$. To initiate a write cycle $\overline{\text{CE}}$ and $\overline{\text{WE}}$ must be a logical zero while $\overline{\text{OE}}$ is a logical one.

Power-Up Write Inhibit

Power-up of the device with $\overline{\text{WE}} = \overline{\text{CE}} = V_{IL}$ and $\overline{\text{OE}} = V_{IH}$ will not accept commands on the rising edge of $\overline{\text{WE}}$. The internal state machine is automatically reset to the read mode on power-up.

■ ABSOLUTE MAXIMUM RATINGS

Storage Temperature	-55°C to +125°C
Ambient Temperature with Power Applied	-40°C to +85°C
Voltage with Respect to Ground All pins except A ₉ , \overline{OE} , \overline{RESET} (Note 1).....	-2.0 V to +7.0 V
V _{CC} (Note 1)	-2.0 V to +7.0 V
A ₉ , \overline{OE} , \overline{RESET} (Note 2)	-2.0 V to +13.5 V

- Notes:**
1. Minimum DC voltage on input or I/O pins are -0.5 V. During voltage transitions, inputs may negative overshoot V_{SS} to -2.0 V for periods of up to 20 ns. Maximum DC voltage on output and I/O pins are V_{CC} +0.5 V. During voltage transitions, outputs may positive overshoot to V_{CC} +2.0 V for periods of up to 20 ns.
 2. Minimum DC input voltage on A₉, \overline{OE} , and \overline{RESET} pins are -0.5 V. During voltage transitions, A₉, \overline{OE} , and \overline{RESET} pins may negative overshoot V_{SS} to -2.0 V for periods of up to 20 ns. Maximum DC input voltage on A₉, \overline{OE} , and \overline{RESET} pins are +13.0 V which may positive overshoot to 14.0 V for periods of up to 20 ns.

WARNING: Semiconductor devices can be permanently damaged by application of stress (voltage, current, temperature, etc.) in excess of absolute maximum ratings. Do not exceed these ratings.

■ RECOMMENDED OPERATING RANGES

Ambient Temperature (T _A)	
Ambient Temperature for MBM29F033C-70	-20°C to +70°C
Ambient Temperature for MBM29F033C-90/-12	-40°C to +85°C
V _{CC} Supply Voltages	
V _{CC} Supply Voltages for MBM29F033C-70	+4.75 V to +5.25 V
V _{CC} Supply Voltages for MBM29F033C-90/-12	+4.50 V to + 5.50 V

Operating ranges define those limits between which the functionality of the device is guaranteed.

WARNING: The recommended operating conditions are required in order to ensure the normal operation of the semiconductor device. All of the device's electrical characteristics are warranted when the device is operated within these ranges.

Always use semiconductor devices within their recommended operating condition ranges. Operation outside these ranges may adversely affect reliability and could result in device failure.

No warranty is made with respect to uses, operating conditions, or combinations not represented on the data sheet. Users considering application outside the listed conditions are advised to contact their FUJITSU representatives beforehand.

■ MAXIMUM OVERSHOOT

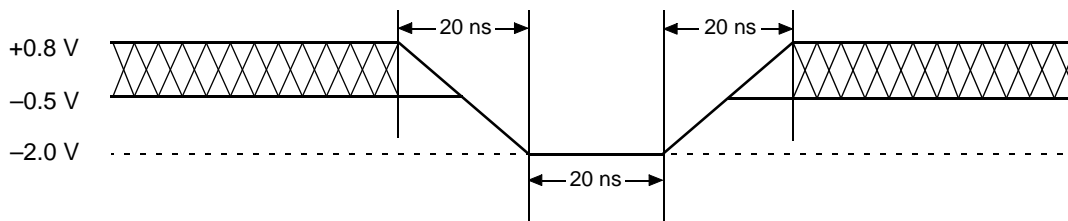

Figure 1 Maximum Negative Overshoot Waveform

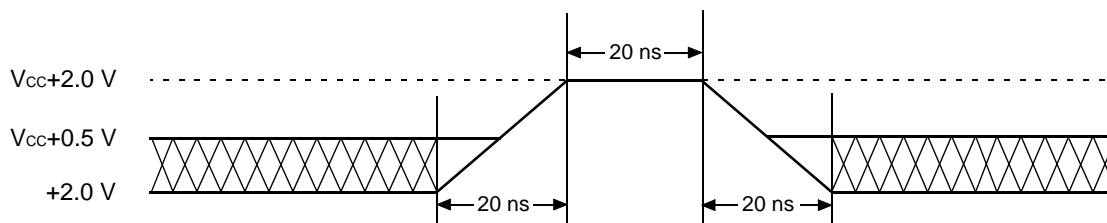
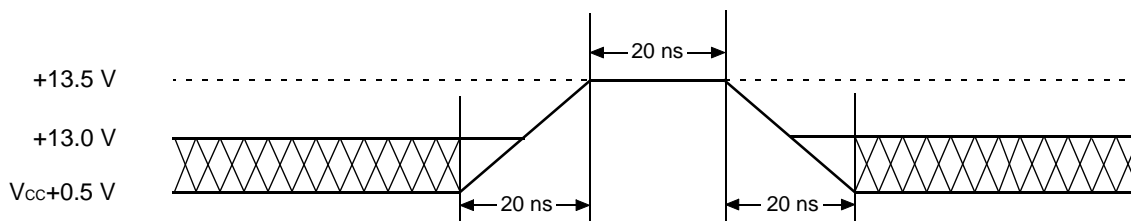

Figure 2 Maximum Positive Overshoot Waveform



Note: This waveform is applied for A_9 , \overline{OE} , and \overline{RESET} .

Figure 3 Maximum Positive Overshoot Waveform

■ DC CHARACTERISTICS

Parameter Symbol	Parameter Description	Test Conditions	Min.	Max.	Unit
I _{LI}	Input Leakage Current	V _{IN} = V _{SS} to V _{CC} , V _{CC} = V _{CC} Max.	-1.0	+1.0	μA
I _{LO}	Output Leakage Current	V _{OUT} = V _{SS} to V _{CC} , V _{CC} = V _{CC} Max.	-1.0	+1.0	μA
I _{LIT}	A ₉ , \overline{OE} , \overline{RESET} Inputs Leakage Current	V _{CC} = V _{CC} Max. A ₉ , \overline{OE} , \overline{RESET} = 12.5 V	—	50	μA
I _{CC1}	V _{CC} Active Current (Note 1)	\overline{CE} = V _{IL} , \overline{OE} = V _{IH}	—	40	mA
I _{CC2}	V _{CC} Active Current (Note 2)	\overline{CE} = V _{IL} , \overline{OE} = V _{IH}	—	45	mA
I _{CC3}	V _{CC} Current (Standby)	V _{CC} = V _{CC} Max., \overline{CE} = V _{IH} , \overline{RESET} = V _{IH}	—	1	mA
		V _{CC} = V _{CC} Max., \overline{CE} = V _{CC} ±0.3 V \overline{RESET} = V _{CC} ±0.3 V	1	5	μA
I _{CC4}	V _{CC} Current (Standby, Reset)	V _{CC} = V _{CC} Max., \overline{RESET} = V _{IL}	—	1	mA
		V _{CC} = V _{CC} Max., \overline{RESET} = V _{SS} ±0.3 V	1	5	μA
V _{IL}	Input Low Level	—	-0.5	0.8	V
V _{IH}	Input High Level	—	2.0	V _{CC} +0.5	V
V _{ID}	Voltage for Autoselect and Sector Protection (A ₉ , \overline{OE} , \overline{RESET})	—	11.5	12.5	V
V _{OL}	Output Low Voltage Level	I _{OL} = 12.0 mA, V _{CC} = V _{CC} Min.	—	0.45	V
V _{OH1}	Output High Voltage Level	I _{OH} = -2.5 mA, V _{CC} = V _{CC} Min.	2.4	—	V
V _{OH2}		I _{OH} = -100 μA	V _{CC} -0.4	—	V
V _{LKO}	Low V _{CC} Lock-Out Voltage	—	3.2	4.2	V

- Notes:**
1. The I_{CC} current listed includes both the DC operating current and the frequency dependent component (at 6 MHz). The frequency component typically is 2 mA/MHz, with \overline{OE} at V_{IH}.
 2. I_{CC} active while Embedded Algorithm (program or erase) is in progress.
 3. Applicable to sector protection function.
 4. (V_{ID} - V_{CC}) do not exceed 9 V.

AC CHARACTERISTICS

Read Only Operations Characteristics

Parameter Symbols		Description	Test Setup		-70 (Note1)	-90 (Note2)	-12 (Note2)	Unit
JEDEC	Standard							
t _{AVAV}	t _{RC}	Read Cycle Time	—	Min.	70	90	120	ns
t _{AVQV}	t _{ACC}	Address to Output Delay	$\overline{CE} = V_{IL}$ $\overline{OE} = V_{IL}$	Max.	70	90	120	ns
t _{ELQV}	t _{CE}	Chip Enable to Output Delay	$\overline{OE} = V_{IL}$	Max.	70	90	120	ns
t _{GLQV}	t _{OE}	Output Enable to Output Delay	—	Max.	40	40	50	ns
t _{EHQZ}	t _{DF}	Chip Enable to Output High-Z	—	Max.	20	20	30	ns
t _{GHQZ}	t _{DF}	Output Enable to Output High-Z	—	Max.	20	20	30	ns
t _{AXQX}	t _{OH}	Output Hold Time From Addresses, \overline{CE} or \overline{OE} , Whichever Occurs First	—	Min.	0	0	0	ns
—	t _{READY}	\overline{RESET} Pin Low to Read Mode	—	Max.	20	20	20	μs

Note1: Test Conditions:

Output Load: 1 TTL gate and 30 pF
 Input rise and fall times: 5 ns
 Input pulse levels: 0.0 V to 3.0 V
 Timing measurement reference level
 Input: 1.5 V
 Output: 1.5 V

Note2: Test Conditions:

Output Load: 1 TTL gate and 100 pF
 Input rise and fall times: 5 ns
 Input pulse levels: 0.45 V to 2.4 V
 Timing measurement reference level
 Input: 0.8 V and 2.0 V
 Output: 0.8 V and 2.0 V

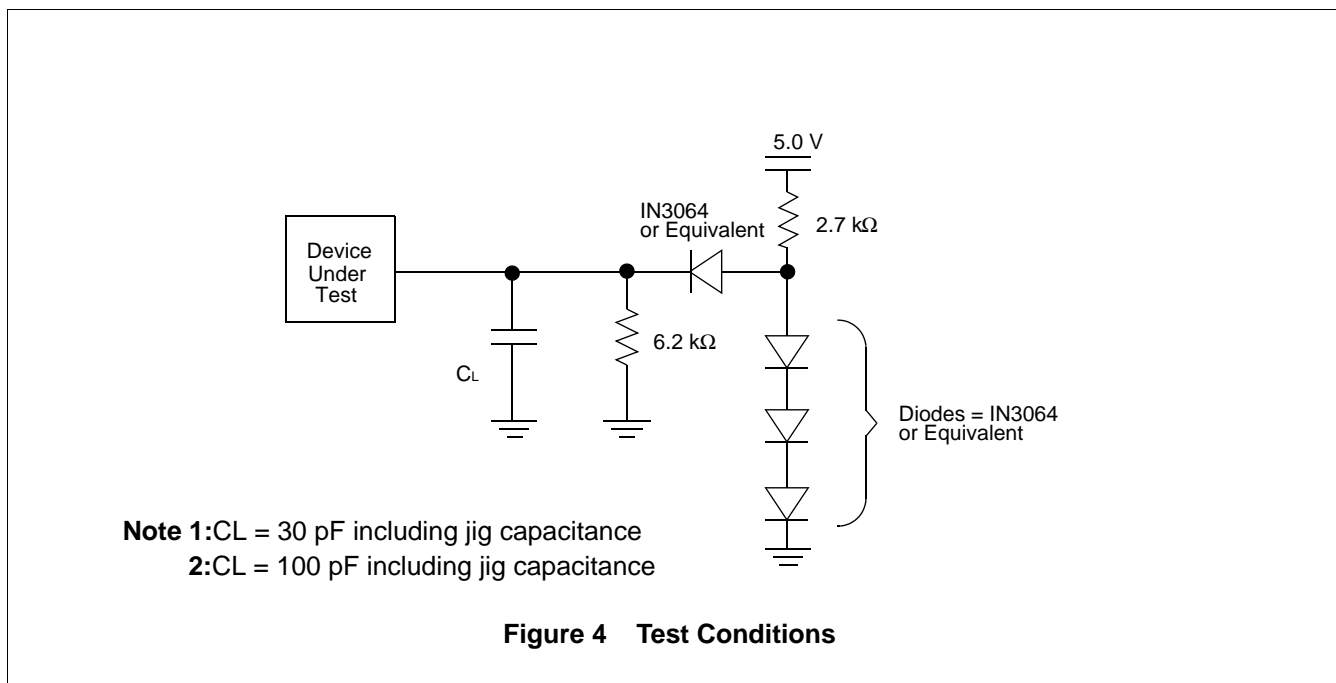

• Write (Erase/Program) Operations

Parameter Symbols		Description		-70	-90	-12	Unit
JEDEC	Standard						
t _{AVAV}	t _{WC}	Write Cycle Time	Min.	70	90	120	ns
t _{AVWL}	t _{AS}	Address Setup Time	Min.	0	0	0	ns
t _{WLAX}	t _{AH}	Address Hold Time	Min.	45	45	50	ns
t _{DVWH}	t _{DS}	Data Setup Time	Min.	30	45	50	ns
t _{WHDX}	t _{DH}	Data Hold Time	Min.	0	0	0	ns
—	t _{OES}	Output Enable Setup Time	Min.	0	0	0	ns
—	t _{OEH}	Output Enable Hold Time	Read	Min.	0	0	ns
			Toggle and $\overline{\text{Data}}$ Polling	Min.	10	10	ns
t _{GHWL}	t _{GHWL}	Read Recover Time Before Write ($\overline{\text{OE}}$ High to $\overline{\text{WE}}$ Low)	Min.	0	0	0	ns
t _{GHEL}	t _{GHEL}	Read Recover Time Before Write ($\overline{\text{OE}}$ High to $\overline{\text{CE}}$ Low)	Min.	0	0	0	ns
t _{ELWL}	t _{CS}	$\overline{\text{CE}}$ Setup Time	Min.	0	0	0	ns
t _{WLEL}	t _{WS}	$\overline{\text{WE}}$ Setup Time	Min.	0	0	0	ns
t _{WHEH}	t _{CH}	$\overline{\text{CE}}$ Hold Time	Min.	0	0	0	ns
t _{EHWH}	t _{WH}	$\overline{\text{WE}}$ Hold Time	Min.	0	0	0	ns
t _{WLWH}	t _{WP}	Write Pulse Width	Min.	35	45	50	ns
t _{ELEH}	t _{CP}	$\overline{\text{CE}}$ Pulse Width	Min.	35	45	50	ns
t _{WHWL}	t _{WPH}	Write Pulse Width High	Min.	20	20	20	ns
t _{EHEL}	t _{CPH}	$\overline{\text{CE}}$ Pulse Width High	Min.	20	20	20	ns
t _{WHWH1}	t _{WHWH1}	Programming Operation	Typ.	8	8	8	μs
t _{WHWH2}	t _{WHWH2}	Sector Erase Operation (Note 1)	Typ.	1	1	1	sec
—	t _{EOE}	Delay Time from Embedded Output Enable	Max.	40	40	50	ns
—	t _{VCS}	V _{CC} Setup Time	Min.	50	50	50	μs
—	t _{VLHT}	Voltage Transition Time (Note 2)	Min.	4	4	4	μs
—	t _{WPP}	Write Pulse Width (Note 2)	Min.	100	100	100	μs
—	t _{OESP}	$\overline{\text{OE}}$ Setup Time to $\overline{\text{WE}}$ Active (Note 2)	Min.	4	4	4	μs
—	t _{CSP}	$\overline{\text{CE}}$ Setup Time to $\overline{\text{WE}}$ Active (Note 2)	Min.	4	4	4	μs
—	t _{RB}	Recover Time From RY/ $\overline{\text{BY}}$	Min.	0	0	0	ns

(Continued)

MBM29F033C-70/-90/-12

(Continued)

Parameter Symbols		Description		-70	-90	-12	Unit
JEDEC	Standard						
—	t_{RH}	\overline{RESET} Hold Time Before Read	Min.	50	50	50	ns
—	t_{BUSY}	Program/Erase Valid to $R\overline{Y}/\overline{B}\overline{Y}$ Delay	Max.	70	90	120	ns
—	t_{VIDR}	Rise Time to V_{ID} (Note 2)	Min.	500	500	500	ns
—	t_{RP}	\overline{RESET} Pulse Width	Min.	500	500	500	ns

- Notes:** 1. This does not include the preprogramming time.
2. This timing is for Sector Protection operation.

SWITCHING WAVEFORMS

Key to Switching Waveforms

WAVEFORM	INPUTS	OUTPUTS
	Must Be Steady	Will Be Steady
	May Change from H to L	Will Be Changing from H to L
	May Change from L to H	Will Be Changing from L to H
	H or L Any Change Permitted	Changing, State Unknown
	Does Not Apply	Center Line is High-Impedance "Off" State

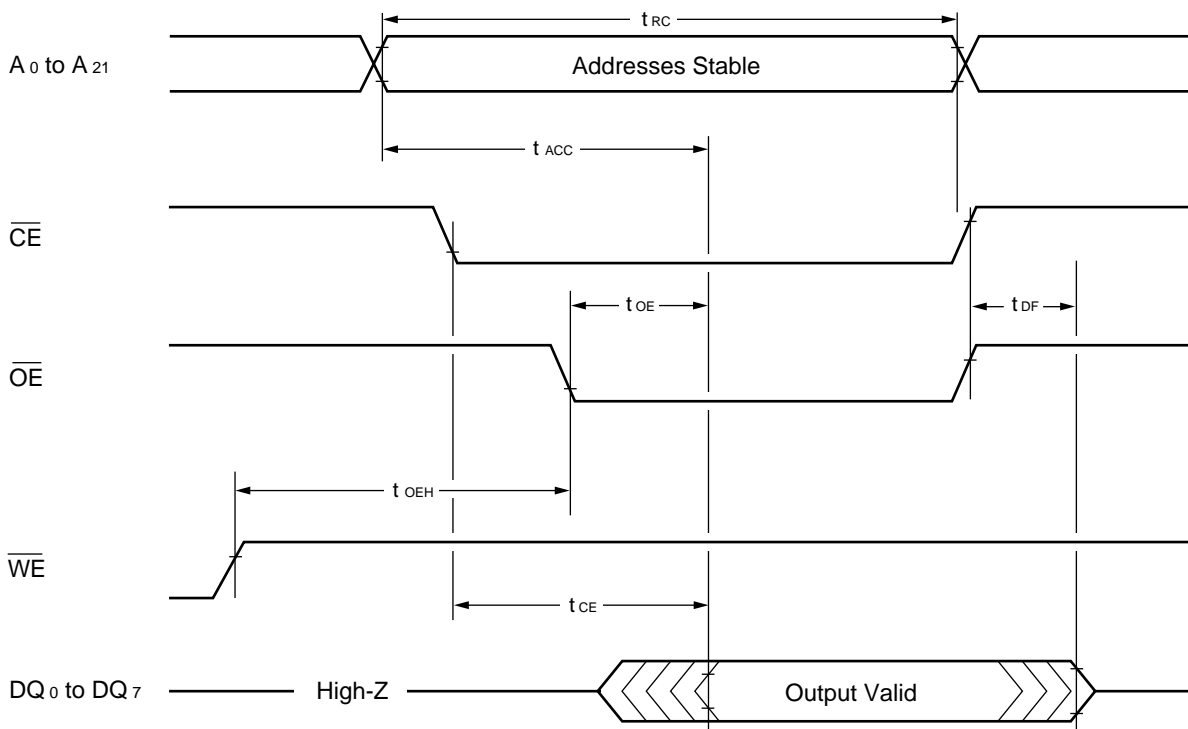
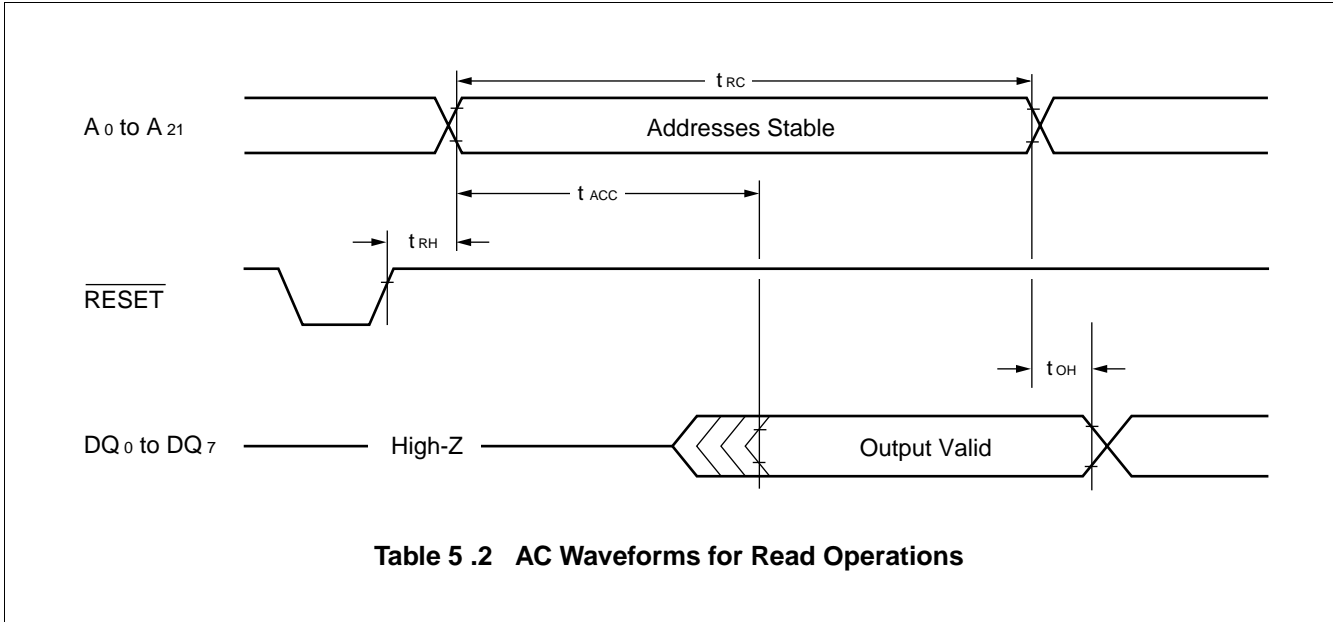
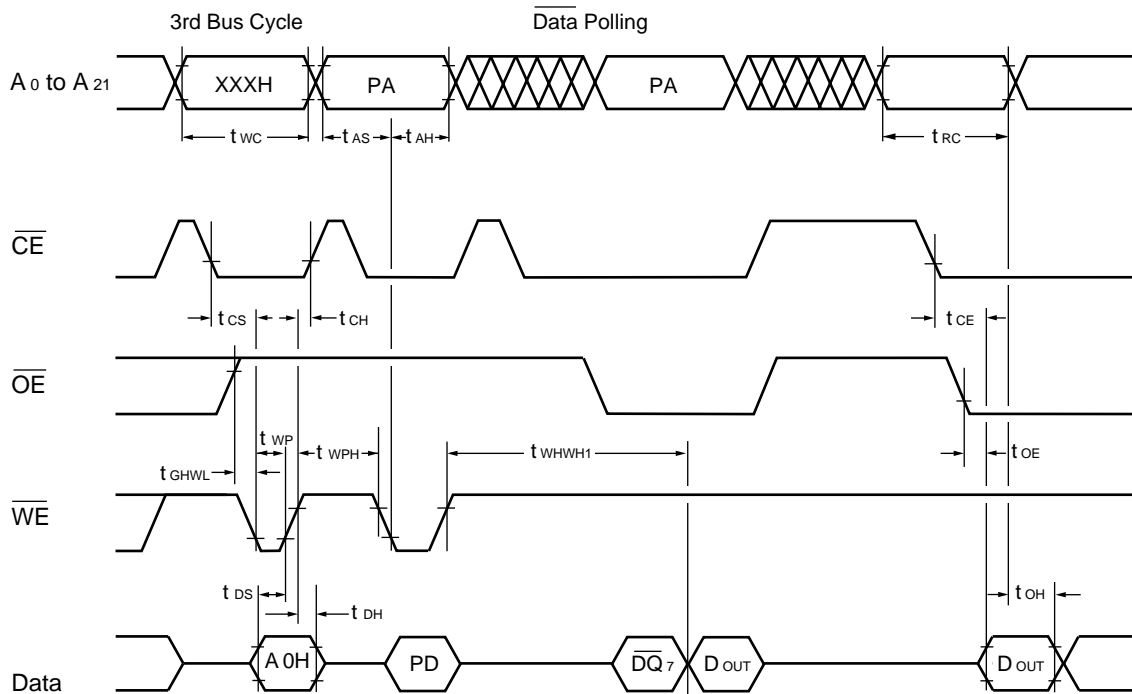

Table 5.1 AC Waveforms for Read Operations





- Notes:**
1. PA is address of the memory location to be programmed.
 2. PD is data to be programmed at byte address.
 3. \overline{DQ}_7 is the output of the complement of the data written to the device.
 4. D_{OUT} is the output of the data written to the device.
 5. Figure indicates last two bus cycles of four bus cycle sequence.

Figure 6 Alternate \overline{WE} Controlled Program Operation Timings

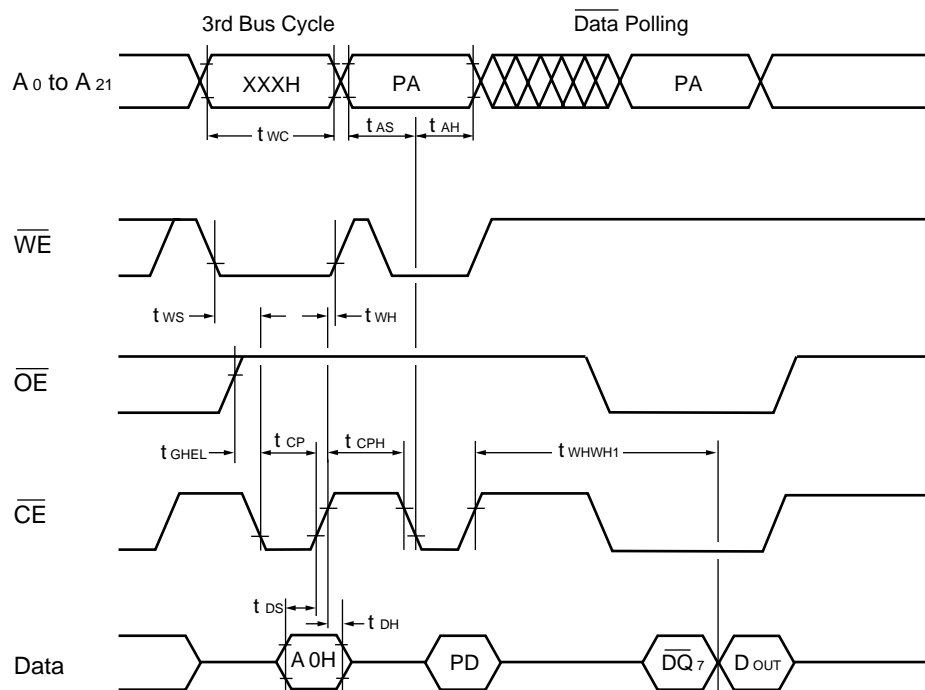

- Notes:**
1. PA is address of the memory location to be programmed.
 2. PD is data to be programmed at byte address.
 3. \overline{DQ}_7 is the output of the complement of the data written to the device.
 4. D_{OUT} is the output of the data written to the device.
 5. Figure indicates last two bus cycles of four bus cycle sequence.

Figure 7 Alternate \overline{CE} Controlled Program Operation Timings

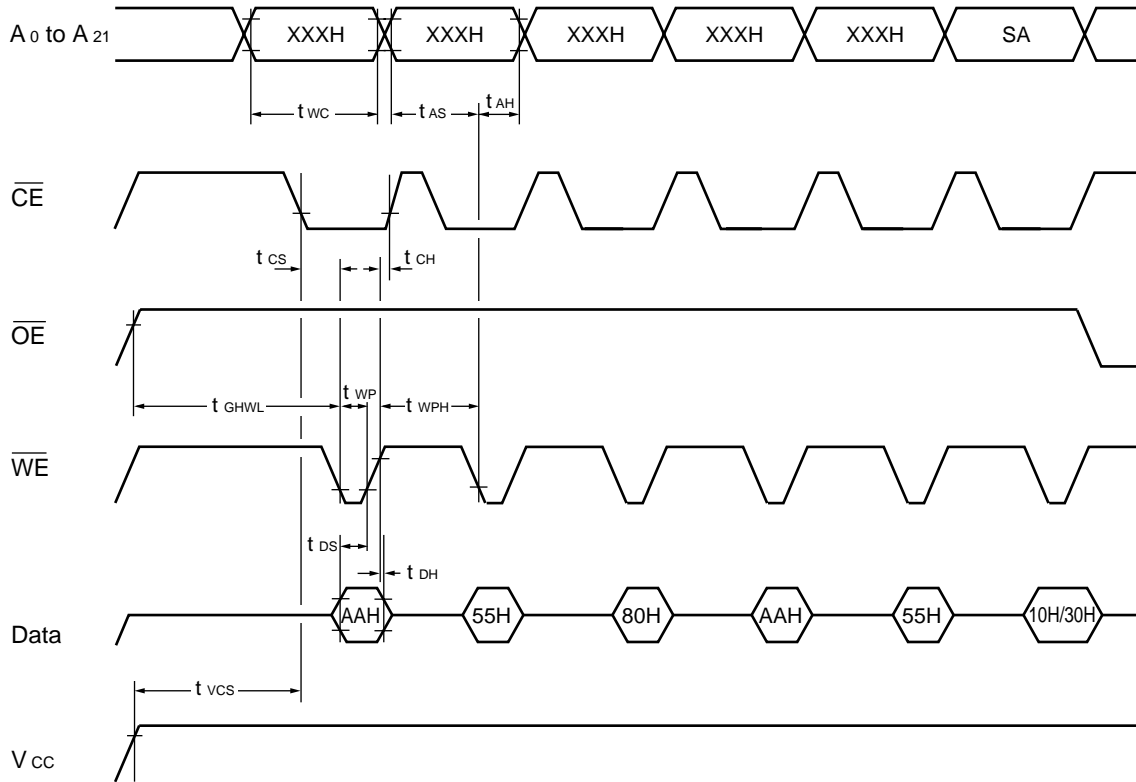

Note: SA is the sector address for Sector Erase. Addresses = XXXH for Chip Erase.

Figure 8 AC Waveforms Chip/Sector Erase Operations

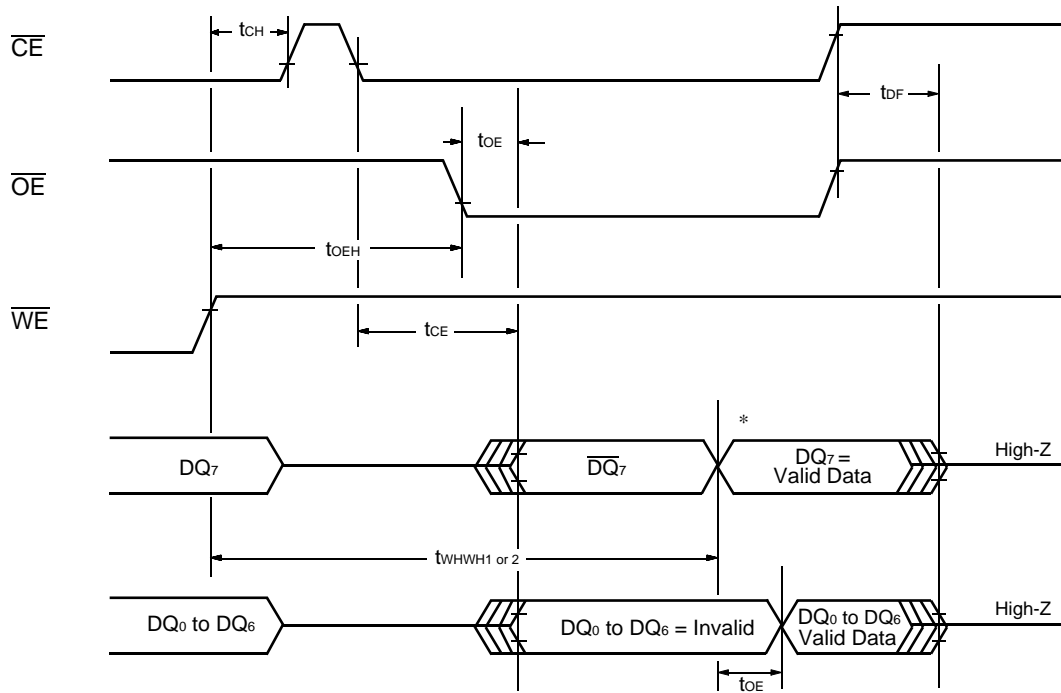

* : DQ_7 = Valid Data (The device has completed the Embedded operation).

Figure 9 AC Waveforms for \overline{Data} Polling During Embedded Algorithm Operations

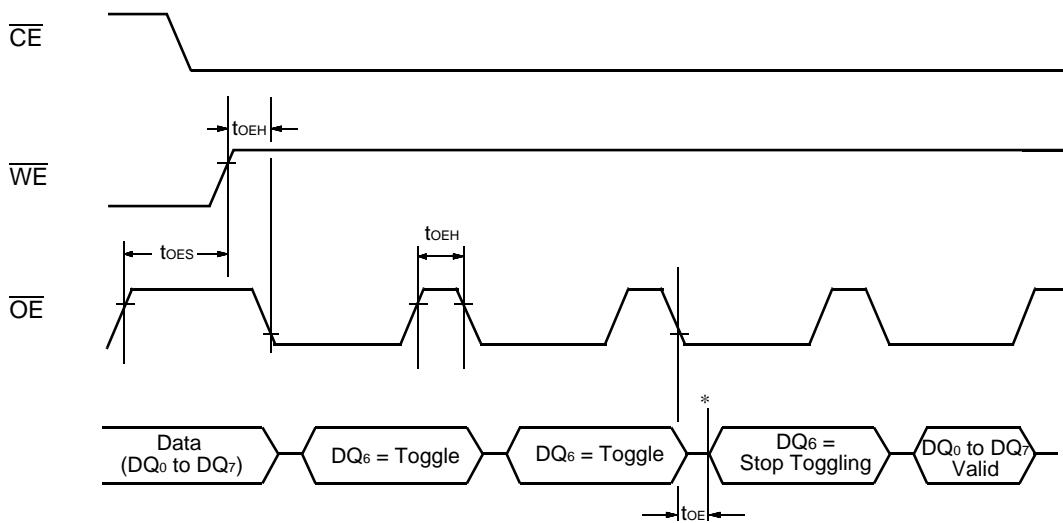

* : DQ_6 = Stops Toggling (The device has completed the Embedded operation).

Figure 10 AC Waveforms for Toggle Bit I During Embedded Algorithm Operations

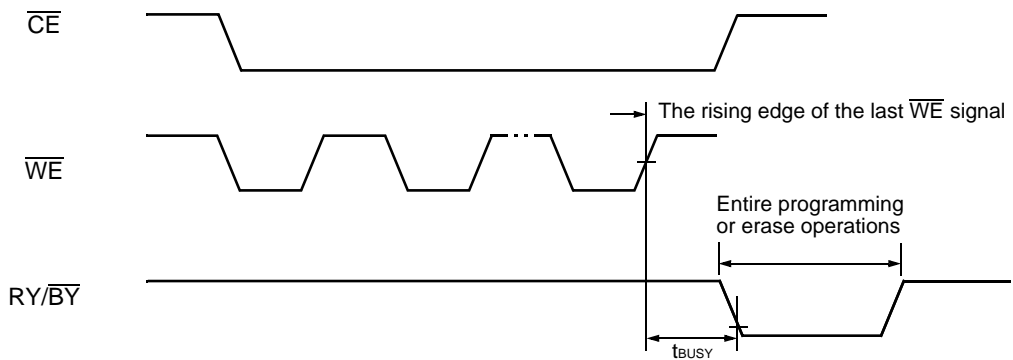

Figure 11 RY/\overline{BY} Timing Diagram During Program/Erase Operations

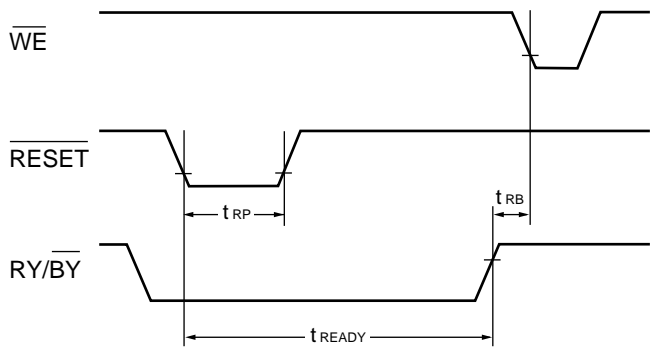
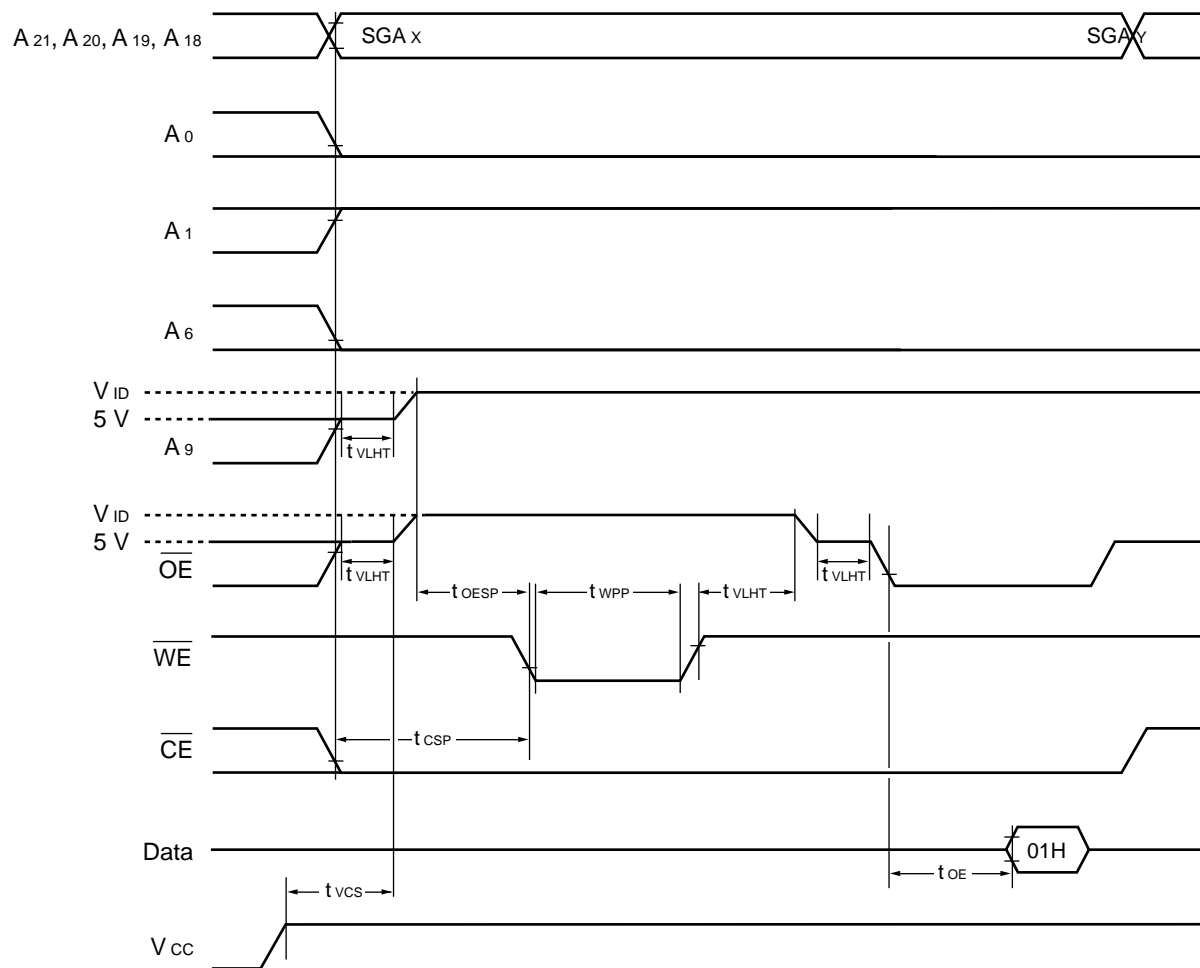
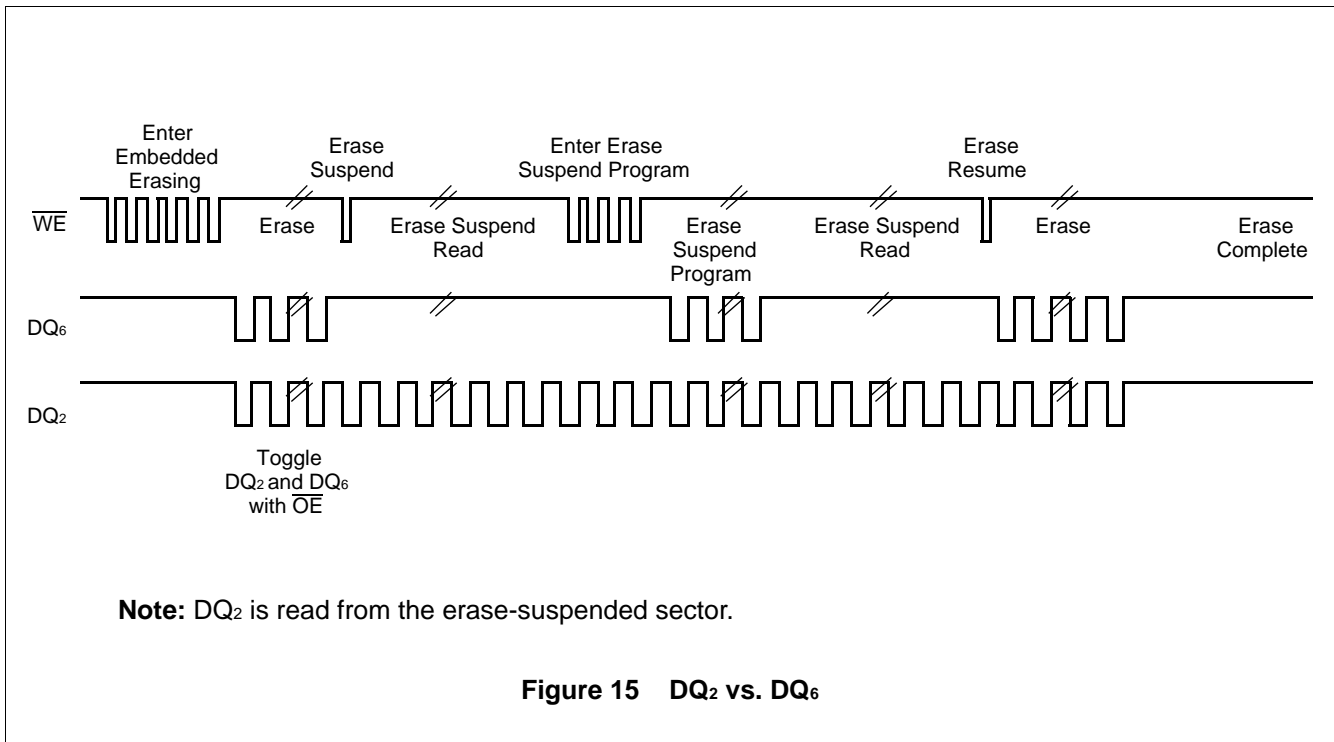
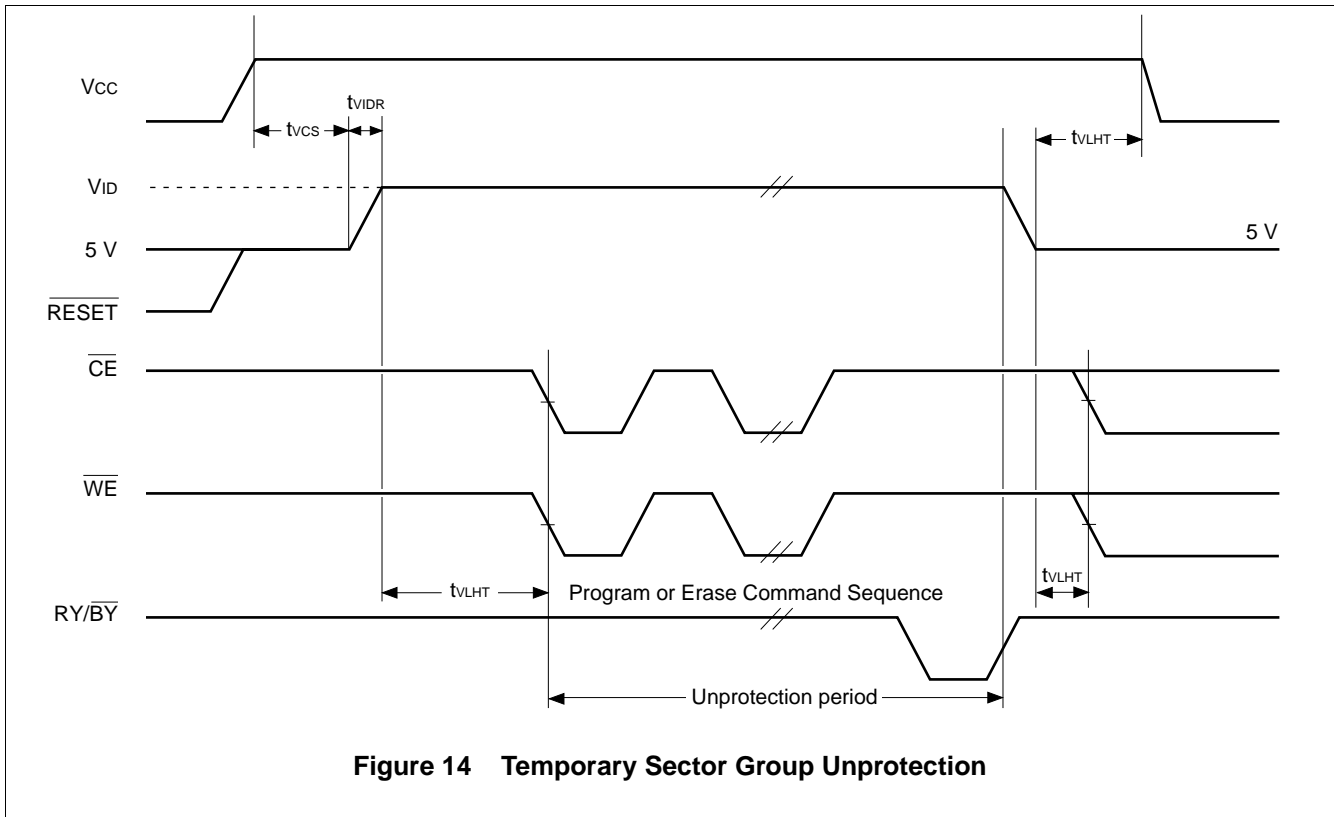

Figure 12 \overline{RESET} Timing Diagram



SGA_x = Sector Group Address for initial sector
 SGA_y = Sector Group Address for next sector

Figure 13 AC Waveforms for Sector Group Protection



EMBEDDED ALGORITHMS

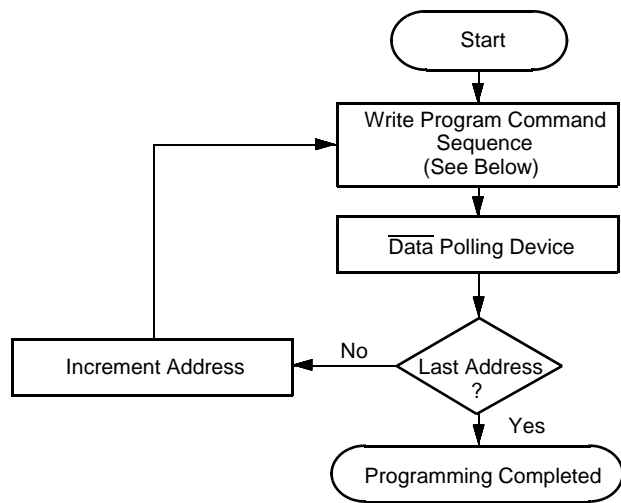

Program Command Sequence (Address/Command):

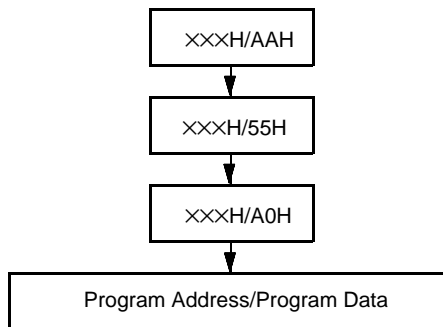
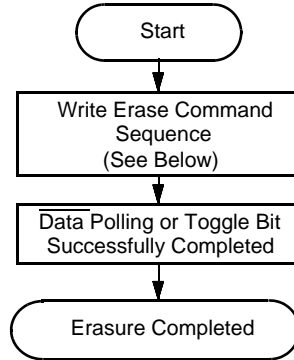
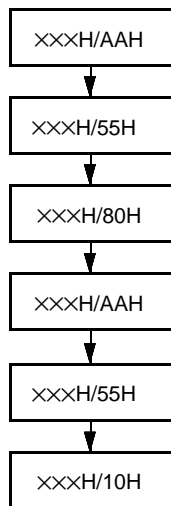

Figure 16 Embedded Programming Algorithm

EMBEDDED ALGORITHMS



Chip Erase Command Sequence*
(Address/Command):



Individual Sector/Multiple Sector*
Erase Command Sequence
(Address/Command):

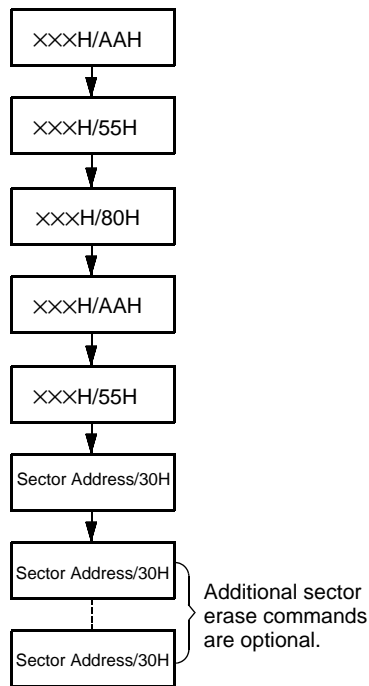

Note: To insure the command has been accepted, the system software should check the status of DQ₃ prior to and following each subsequent sector erase command. If DQ₃ were high on the second status check, the command may not have been accepted.

Figure 17 Embedded Erase™ Algorithm

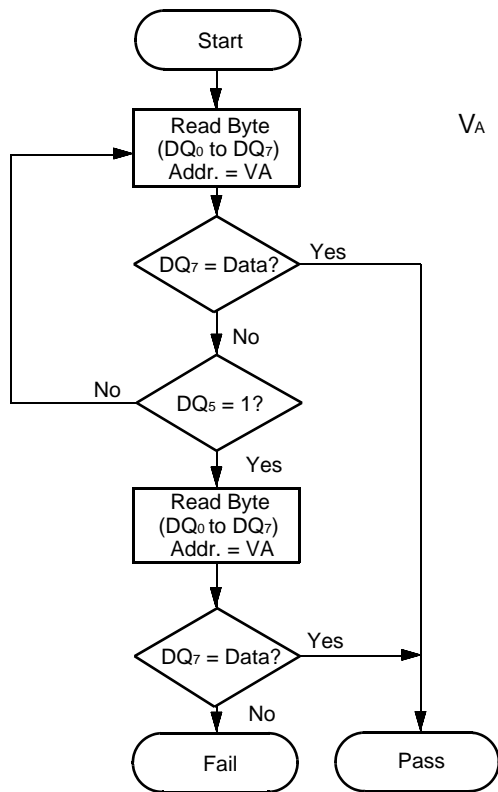

V_A = Byte address for programming
 = Any of the sector addresses within the sector being erased during sector erase operation
 = Any of the sector group address within the sector not being protected during chip erase operation.

Note: DQ_7 is rechecked even if $DQ_5 = "1"$ because DQ_7 may change simultaneously with DQ_5 .

Figure 18 $\overline{\text{Data}}$ Polling Algorithm

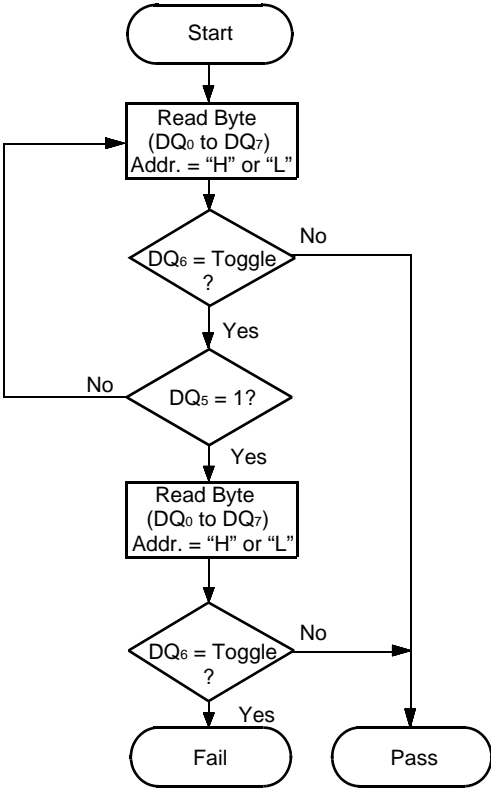

Note: DQ₆ is rechecked even if DQ₅ = "1" because DQ₆ may stop toggling at the same time as DQ₅ changing to "1".

Figure 19 Toggle Bit I Algorithm

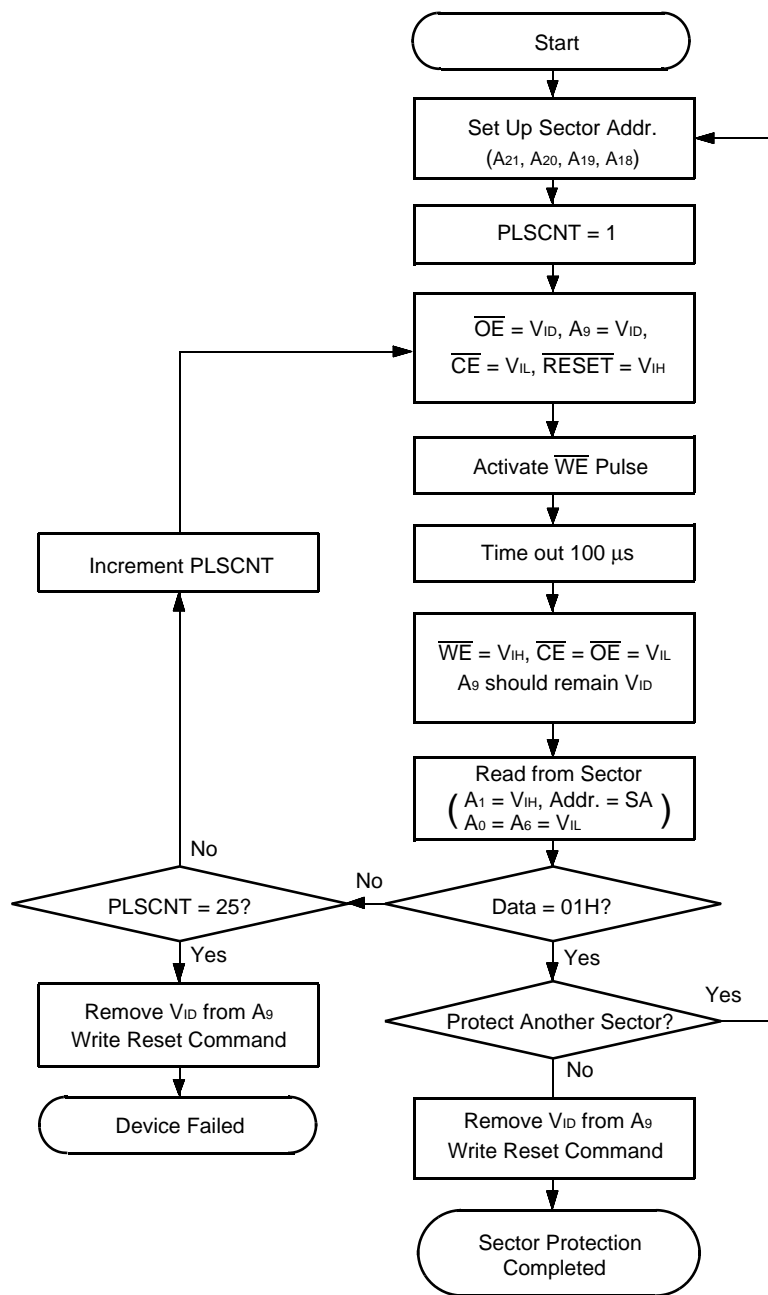
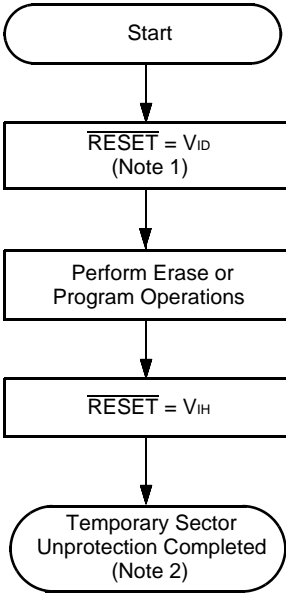

Figure 20 Sector Group Protection Algorithm



- Notes:** 1. All Protected sector groups unprotected.
2. All previously protected sector groups are protected once again.

Figure 21 Temporary Sector Group Unprotection Algorithm

■ ERASE AND PROGRAMMING PERFORMANCE

Parameter	Limits			Unit	Comments
	Min.	Typ.	Max.		
Sector Erase Time	—	1	8	sec	Excludes 00H programming prior to erasure
Byte Programming Time	—	8	150	μs	Excludes system-level overhead
Chip Programming Time	—	33.6	80	sec	Excludes system-level overhead
Erase/Program Cycle	100,000	—	—	Cycles	

■ TSOP PIN CAPACITANCE

Parameter Symbol	Parameter Description	Test Setup	Typ.	Max.	Unit
C _{IN1}	Input Capacitance	V _{IN} = 0	8	10	pF
C _{OUT}	Output Capacitance	V _{OUT} = 0	8	10	pF
C _{IN2}	Control Pin Capacitance	V _{IN} = 0	9	10	pF

Note: Test conditions T_A = 25°C, f = 1.0 MHz

PACKAGE DIMENSIONS

40-pin plastic TSOP(I)
(FPT-40P-M06)

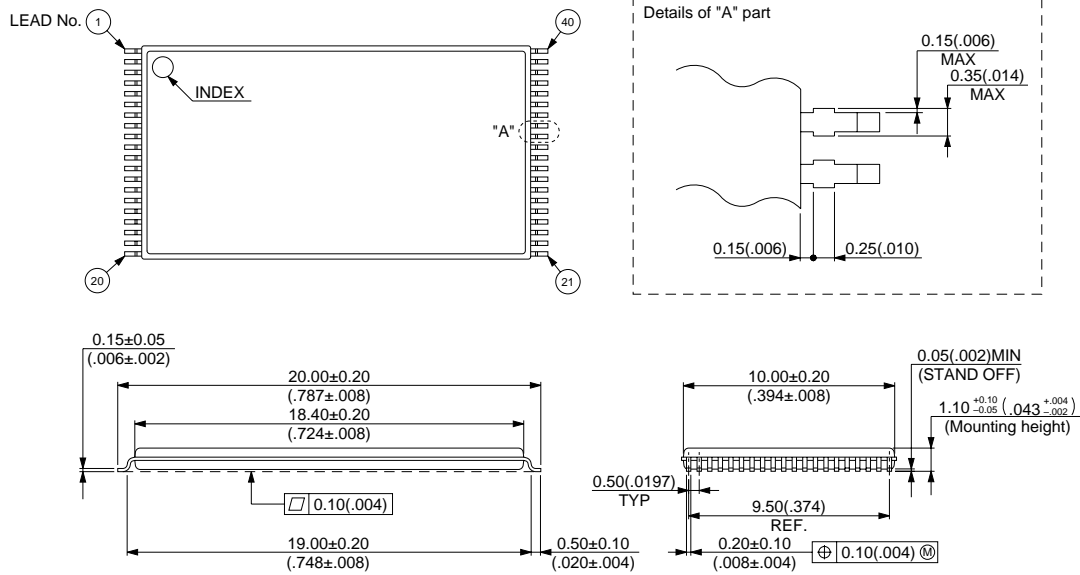

© 1994 FUJITSU LIMITED F40007S-1C-1

Dimensions in mm (inches).

40-pin plastic TSOP(I)
(FPT-40P-M07)

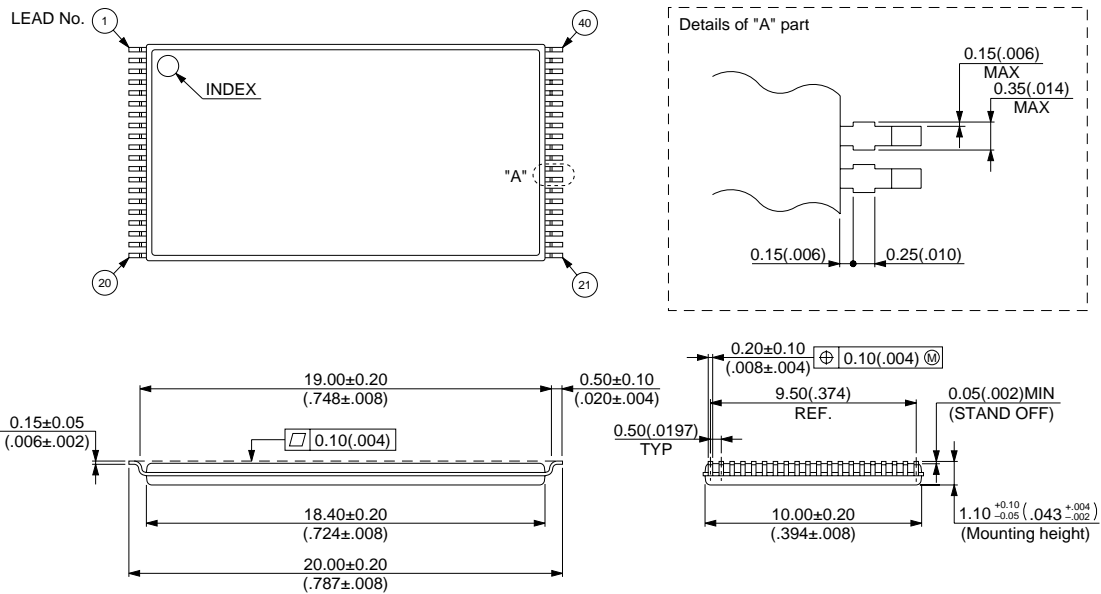

© 1994 FUJITSU LIMITED F40008S-1C-1

Dimensions in mm (inches).

FUJITSU LIMITED

For further information please contact:

Japan

FUJITSU LIMITED
Corporate Global Business Support Division
Electronic Devices
KAWASAKI PLANT, 4-1-1, Kamikodanaka
Nakahara-ku, Kawasaki-shi
Kanagawa 211-8588, Japan
Tel: 81(44) 754-3763
Fax: 81(44) 754-3329

<http://www.fujitsu.co.jp/>

North and South America

FUJITSU MICROELECTRONICS, INC.
Semiconductor Division
3545 North First Street
San Jose, CA 95134-1804, USA
Tel: (408) 922-9000
Fax: (408) 922-9179

Customer Response Center
Mon. - Fri.: 7 am - 5 pm (PST)
Tel: (800) 866-8608
Fax: (408) 922-9179

<http://www.fujitsumicro.com/>

Europe

FUJITSU MIKROELEKTRONIK GmbH
Am Siebenstein 6-10
D-63303 Dreieich-Buchsschlag
Germany
Tel: (06103) 690-0
Fax: (06103) 690-122

<http://www.fujitsu-ede.com/>

Asia Pacific

FUJITSU MICROELECTRONICS ASIA PTE LTD
#05-08, 151 Lorong Chuan
New Tech Park
Singapore 556741
Tel: (65) 281-0770
Fax: (65) 281-0220

<http://www.fmap.com.sg/>

F9903

© FUJITSU LIMITED Printed in Japan

All Rights Reserved.

The contents of this document are subject to change without notice. Customers are advised to consult with FUJITSU sales representatives before ordering.

The information and circuit diagrams in this document are presented as examples of semiconductor device applications, and are not intended to be incorporated in devices for actual use. Also, FUJITSU is unable to assume responsibility for infringement of any patent rights or other rights of third parties arising from the use of this information or circuit diagrams.

FUJITSU semiconductor devices are intended for use in standard applications (computers, office automation and other office equipment, industrial, communications, and measurement equipment, personal or household devices, etc.).

CAUTION:

Customers considering the use of our products in special applications where failure or abnormal operation may directly affect human lives or cause physical injury or property damage, or where extremely high levels of reliability are demanded (such as aerospace systems, atomic energy controls, sea floor repeaters, vehicle operating controls, medical devices for life support, etc.) are requested to consult with FUJITSU sales representatives before such use. The company will not be responsible for damages arising from such use without prior approval.

Any semiconductor devices have an inherent chance of failure. You must protect against injury, damage or loss from such failures by incorporating safety design measures into your facility and equipment such as redundancy, fire protection, and prevention of over-current levels and other abnormal operating conditions.

If any products described in this document represent goods or technologies subject to certain restrictions on export under the Foreign Exchange and Foreign Trade Law of Japan, the prior authorization by Japanese government will be required for export of those products from Japan.