

FLASH MEMORY

CMOS

4M (512K × 8) BIT

MBM29F040C-55/-70/-90

■ FEATURES

- **Single 5.0 V read, program and erase**
Minimizes system level power requirements
- **Compatible with JEDEC-standard commands**
Uses same software commands as E²PROMs
- **Compatible with JEDEC-standard byte-wide pinouts**
32-pin PLCC (Package suffix: PD)
32-pin TSOP(I) (Package suffix: PF)
32-pin TSOP(I) (Package suffix: PFTN – Normal Bend Type, PFTR – Reversed Bend Type)
- **Minimum 100,000 write/erase cycles**
- **High performance**
55 ns maximum access time
- **Sector erase architecture**
8 equal size sectors of 64K bytes each
Any combination of sectors can be concurrently erased. Also supports full chip erase.
- **Embedded Erase™ Algorithms**
Automatically pre-programs and erases the chip or any sector
- **Embedded Program™ Algorithms**
Automatically writes and verifies data at specified address
- **Data Polling and Toggle Bit feature for detection of program or erase cycle completion**
- **Low V_{CC} write inhibit ≤ 3.2 V**
- **Sector protection**
Hardware method disables any combination of sectors from write or erase operations
- **Erase Suspend/Resume**
Suspends the erase operation to allow a read data in another sector within the same device

■ PACKAGE

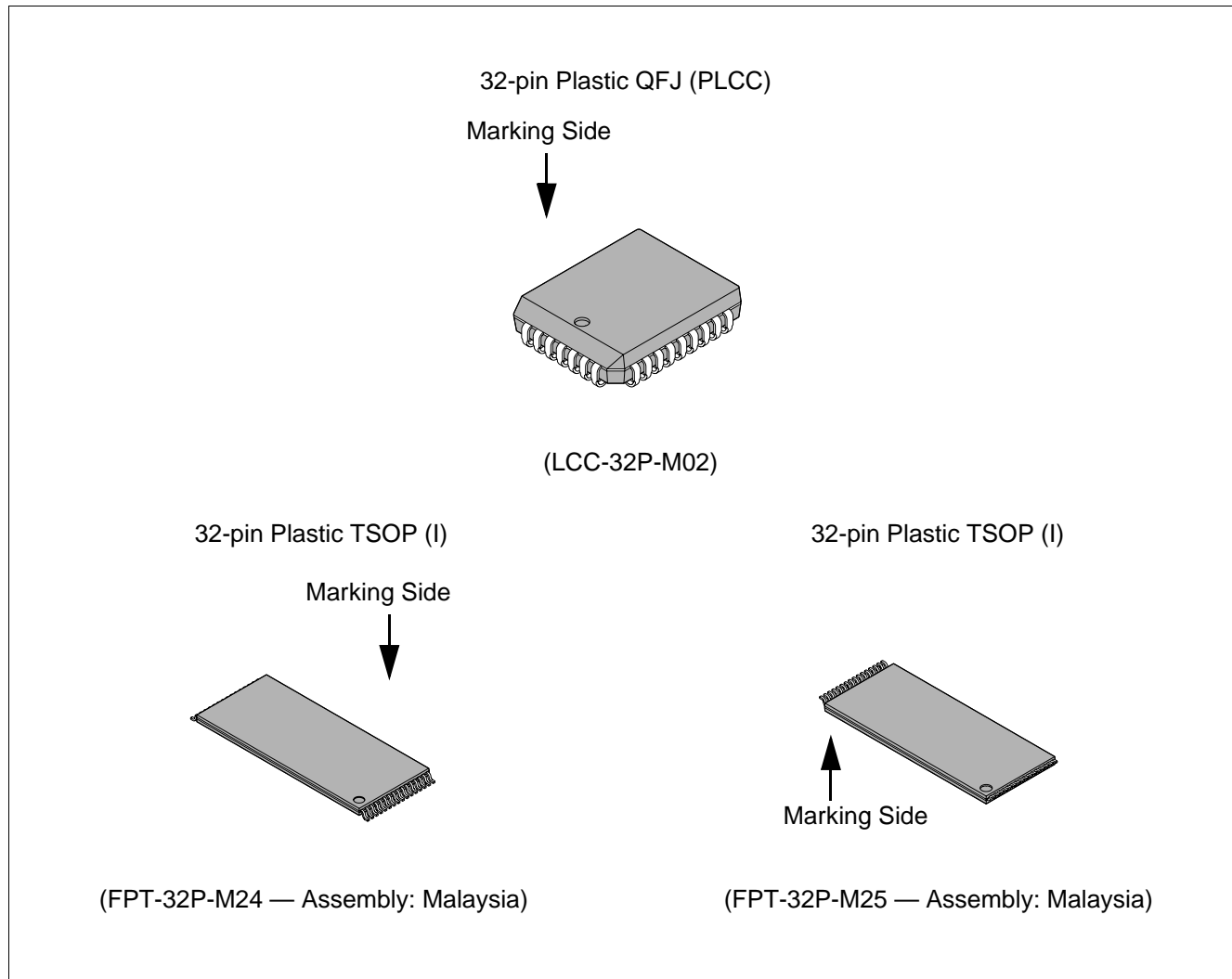

■ GENERAL DESCRIPTION

The MBM29F040C is a 4M-bit, 5.0 V-only Flash memory organized as 512K bytes of 8 bits each. The MBM29F040C is offered in a 32-pin PLCC and 32-pin TSOP(I) package. This device is designed to be programmed in-system with the standard system 5.0 V V_{CC} supply. A 12.0 V V_{PP} is not required for write or erase operations. The device can also be reprogrammed in standard EPROM programmers.

The standard MBM29F040C offers access times 55 ns and 90 ns, allowing operation of high-speed microprocessors without wait states. To eliminate bus contention the device has separate chip enable (\overline{CE}), write enable (\overline{WE}), and output enable (\overline{OE}) controls.

The MBM29F040C is pin and command set compatible with JEDEC standard E²PROMs. Commands are written to the command register using standard microprocessor write timings. Register contents serve as input to an internal state-machine which controls the erase and programming circuitry. Write cycles also internally latch addresses and data needed for the programming and erase operations. Reading data out of the device is similar to reading from 12.0 V Flash or EPROM devices.

The MBM29F040C is programmed by executing the program command sequence. This will invoke the Embedded Program Algorithm which is an internal algorithm that automatically times the program pulse widths and verifies proper cell margin. Typically, each sector can be programmed and verified in less than 0.5 seconds. Erase is accomplished by executing the erase command sequence. This will invoke the Embedded Erase Algorithm which is an internal algorithm that automatically preprograms the array if it is not already programmed before executing the erase operation. During erase, the device automatically times the erase pulse widths and verifies proper cell margin.

Any individual sector is typically erased and verified in 1 second. (If already completely preprogrammed.)

The device also features a sector erase architecture. The sector mode allows for 64K byte sectors of memory to be erased and reprogrammed without affecting other sectors. The MBM29F040C is erased when shipped from the factory.

The device features single 5.0 V power supply operation for both read and write functions. Internally generated and regulated voltages are provided for the program and erase operations. A low V_{CC} detector automatically inhibits write operations on the loss of power. The end of program or erase is detected by \overline{Data} Polling of DQ_7 or by the Toggle Bit feature on DQ_6 . Once the end of a program or erase cycle has been completed, the device internally resets to the read mode.

Fujitsu's Flash technology combines years of EPROM and E²PROM experience to produce the highest levels of quality, reliability and cost effectiveness. The MBM29F040C memory electrically erases the entire chip or all bits within a sector simultaneously via Fowler-Nordheim tunneling. The bytes are programmed one byte at a time using the EPROM programming mechanism of hot electron injection.

■ FLEXIBLE SECTOR-ERASE ARCHITECTURE

- 64K Byte per sector
- Individual-sector, multiple-sector, or bulk-erase capability
- Individual or multiple-sector protection is user definable

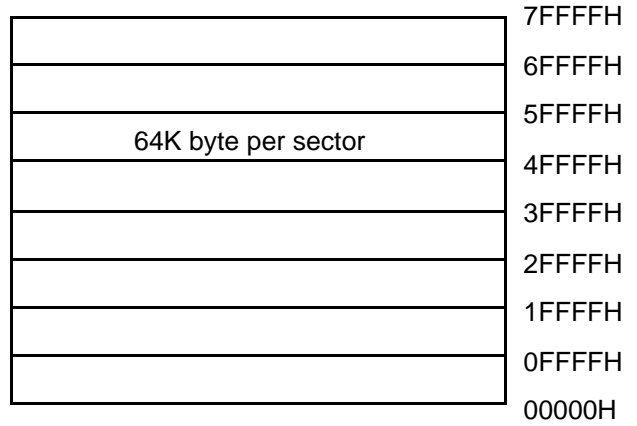

■ PRODUCT LINE UP

Part No.		MBM29F040C		
Ordering Part No.	V _{CC} = 5.0 V ±5%	-55	—	—
	V _{CC} = 5.0 V ±10%	—	-70	-90
Max. Address Access Time (ns)		55	70	90
Max. \overline{CE} Access Time (ns)		55	70	90
Max. \overline{OE} Access Time (ns)		30	30	35

■ BLOCK DIAGRAM

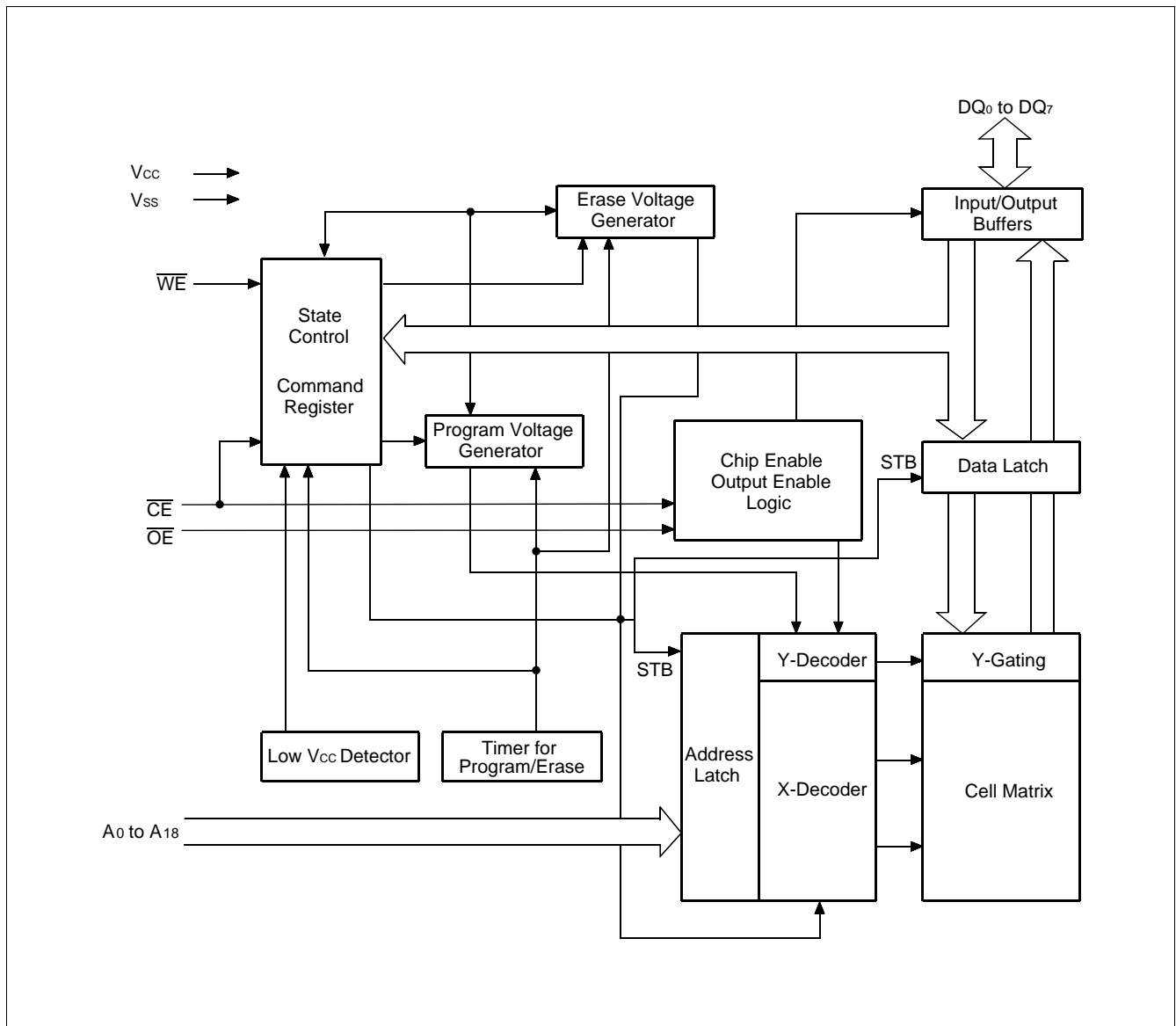

MBM29F040C-55/-70/-90

CONNECTION DIAGRAMS

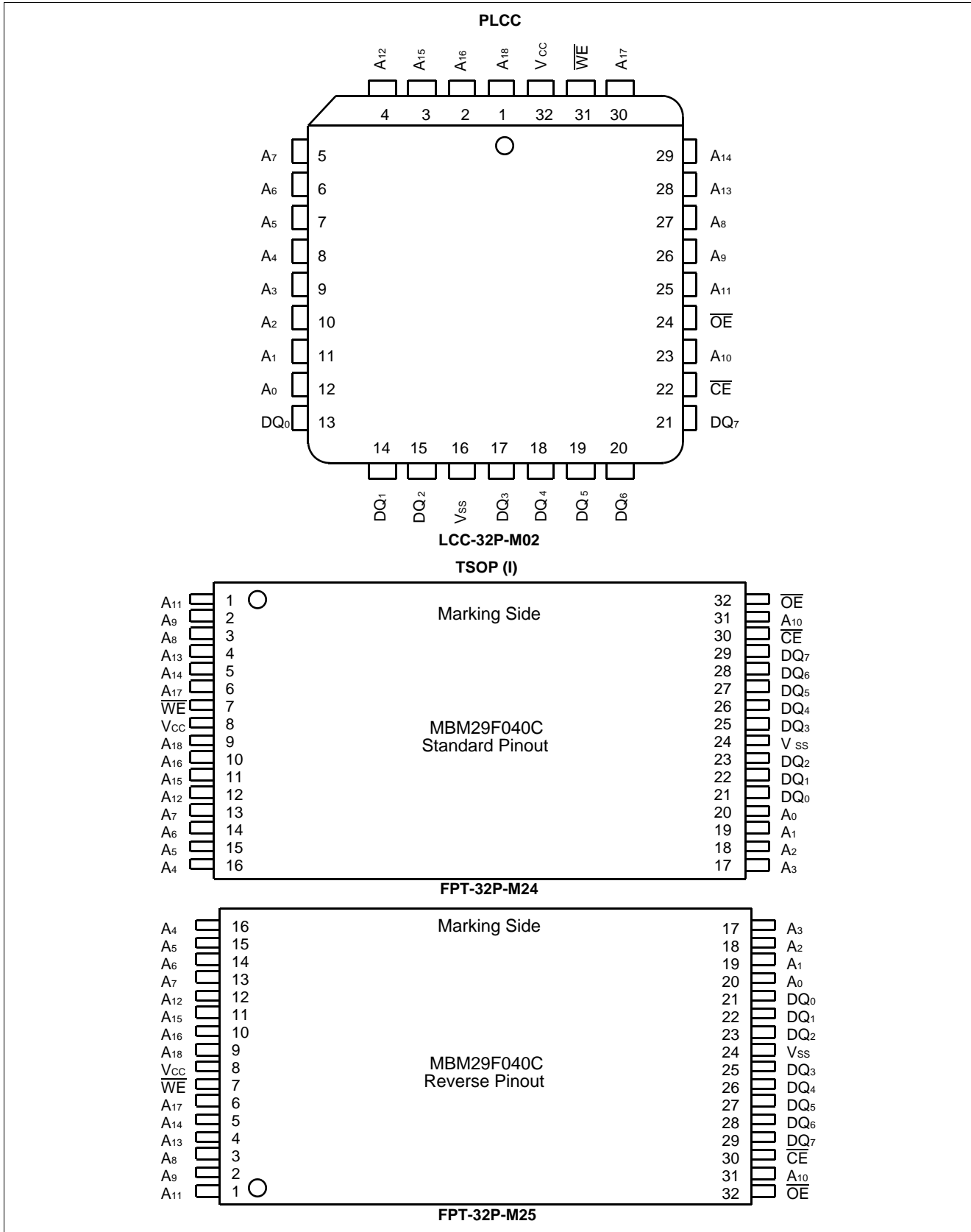

■ LOGIC SYMBOL

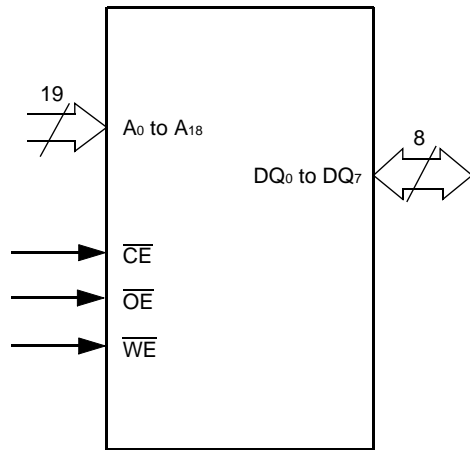

Table 1 MBM29F040C Pin Configuration

Pin	Function
A ₀ to A ₁₈	Address Inputs
DQ ₀ to DQ ₇	Data Inputs/Outputs
\overline{CE}	Chip Enable
\overline{OE}	Output Enable
\overline{WE}	Write Enable
V _{SS}	Device Ground
V _{CC}	Device Power Supply

Table 2 MBM29F040C User Bus Operations

Operation	\overline{CE}	\overline{OE}	\overline{WE}	A ₀	A ₁	A ₆	A ₉	I/O
Auto-Select Manufacturer Code (1)	L	L	H	L	L	L	V _{ID}	Code
Auto-Select Device Code (1)	L	L	H	H	L	L	V _{ID}	Code
Read (3)	L	L	H	A ₀	A ₁	A ₆	A ₉	D _{OUT}
Standby	H	X	X	X	X	X	X	HIGH-Z
Output Disable	L	H	H	X	X	X	X	HIGH-Z
Write (Program/Erase)	L	H	L	A ₀	A ₁	A ₆	A ₉	D _{IN}
Enable Sector Protection (2)	L	V _{ID}	$\overline{\square}$	X	X	X	V _{ID}	X
Verify Sector Protection (2)	L	L	H	L	H	L	V _{ID}	Code

Legend: L = V_{IL}, H = V_{IH}, X = V_{IL} or V_{IH}, $\overline{\square}$ = Pulse Input. See DC Characteristics for voltage levels.

- Notes:**
1. Manufacturer and device codes may also be accessed via a command register write sequence. See Table 5.
 2. Refer to the section on Sector Protection.
 3. \overline{WE} can be V_{IL} if \overline{OE} is V_{IL}, \overline{OE} at V_{IH} initiates the write operations.

MBM29F040C-55/-70/-90

■ ORDERING INFORMATION

Standard Products

Fujitsu standard products are available in several packages. The order number is formed by a combination of:

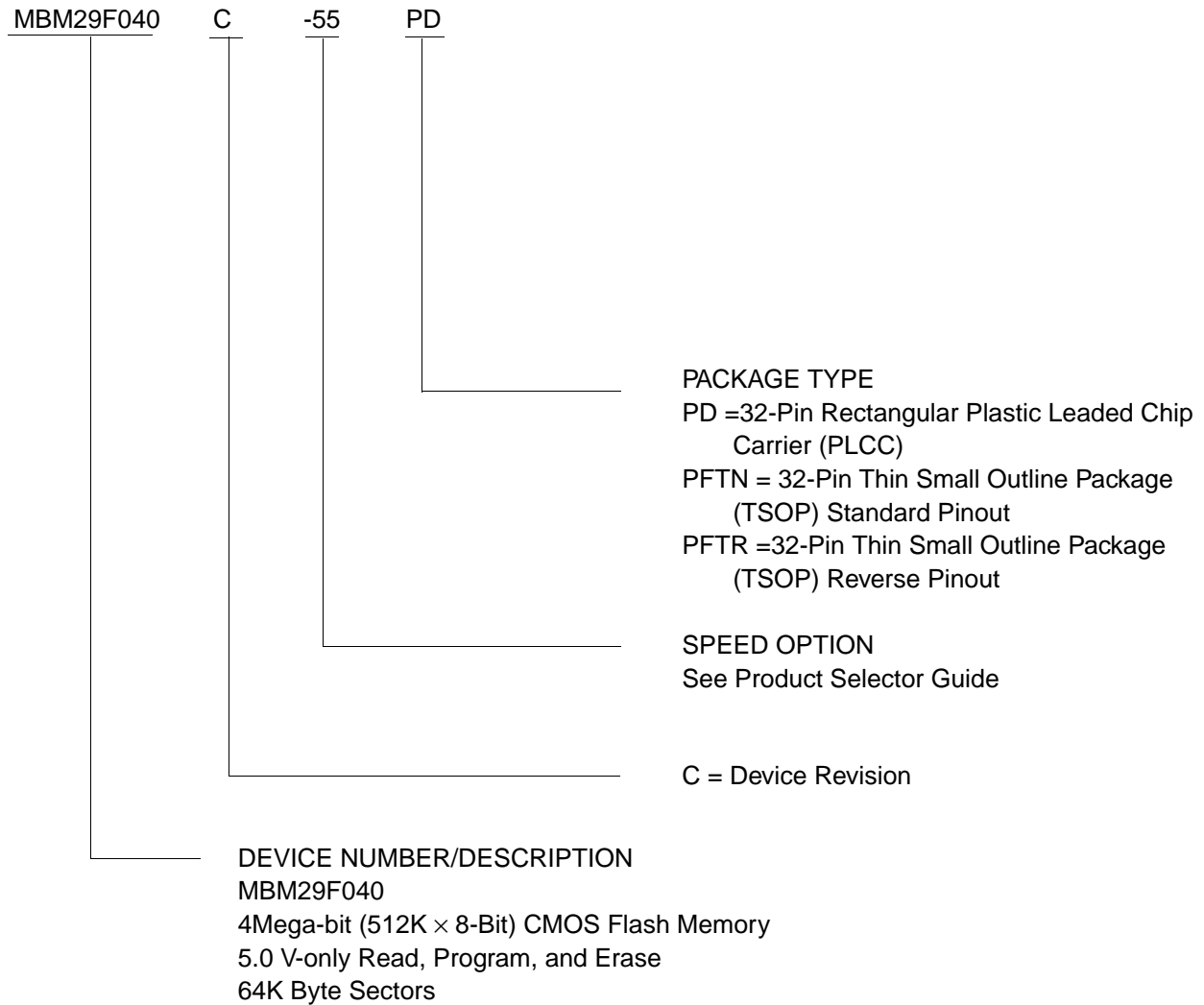

■ FUNCTIONAL DESCRIPTION

Read Mode

The MBM29F040C has two control functions which must be satisfied in order to obtain data at the outputs. \overline{CE} is the power control and should be used for a device selection. \overline{OE} is the output control and should be used to gate data to the output pins if a device is selected.

Address access time (t_{ACC}) is equal to the delay from stable addresses to valid output data. The chip enable access time (t_{CE}) is the delay from stable addresses and stable \overline{CE} to valid data at the output pins. The output enable access time is the delay from the falling edge of \overline{OE} to valid data at the output pins (assuming the addresses have been stable for at least $t_{ACC-tOE}$ time).

Standby Mode

The MBM29F040C has two standby modes, a CMOS standby mode (\overline{CE} input held at $V_{CC} \pm 0.3$ V.), when the current consumed is less than 5 μ A; and a TTL standby mode (\overline{CE} is held at V_{IH}) when the current required is reduced to approximately 1 mA. During Embedded Algorithm operation, V_{CC} Active current (I_{CC2}) is required even $\overline{CE} = V_{IH}$. The device can be read with standard access time (t_{CE}) from either of these standby modes. In the standby mode the outputs are in a high impedance state, independent of the \overline{OE} input.

If the device is deselected during erasure or programming, the device will draw active current until the operation is completed.

Output Disable

With the \overline{OE} input at a logic high level (V_{IH}), output from the device is disabled. This will cause the output pins to be in a high impedance state.

Autoselect

The autoselect mode allows the reading out of a binary code from the device and will identify its manufacturer and type. This mode is intended for use by programming equipment for the purpose of automatically matching the device to be programmed with its corresponding programming algorithm. This mode is functional over the entire temperature range of the device.

To activate this mode, the programming equipment must force V_{ID} (11.5 V to 12.5 V) on address pin A_9 . Two identifier bytes may then be sequenced from the device outputs by toggling address A_0 from V_{IL} to V_{IH} . All addresses are DON'T CARES except A_0 , A_1 , and A_6 . (Recommend V_{IL} for the other pins.)

The manufacturer and device codes may also be read via the command register, for instances when the MBM29F040C is erased or programmed in a system without access to high voltage on the A_9 pin. The command sequence is illustrated in Table 5. (Refer to Autoselect Command section.)

Byte 0 ($A_0 = V_{IL}$) represents the manufacture's code (Fujitsu = 04H) and byte 1 ($A_0 = V_{IH}$) represents the device identifier code (MBM29F040C = A4H). These two bytes are given in the Table 3. All identifiers for manufactures and device will exhibit odd parity with the MSB (DQ_7) defined as the parity bit. In order to read the proper device codes when executing the autoselect, A_1 must be V_{IL} . (See Table 3.)

Table 3 MBM29F040C Sector Protection Verify Autoselect Codes

Type	A ₁₈	A ₁₇	A ₁₆	A ₆	A ₁	A ₀	Code (HEX)	DQ ₇	DQ ₆	DQ ₅	DQ ₄	DQ ₃	DQ ₂	DQ ₁	DQ ₀
Manufacture's Code	X	X	X	V _{IL}	V _{IL}	V _{IL}	04H	0	0	0	0	0	1	0	0
Device Code	X	X	X	V _{IL}	V _{IL}	V _{IH}	A4H	1	0	1	0	0	1	0	0
Sector Protection	Sector Addresses			V _{IL}	V _{IH}	V _{IL}	01H*	0	0	0	0	0	0	0	1

* : Outputs 01H at protected sector addresses and 00H at unprotected sector addresses.

Table 4 Sector Address Tables

Sector Address	A ₁₈	A ₁₇	A ₁₆	Address Range
SA0	0	0	0	00000H to 0FFFFH
SA1	0	0	1	10000H to 1FFFFH
SA2	0	1	0	20000H to 2FFFFH
SA3	0	1	1	30000H to 3FFFFH
SA4	1	0	0	40000H to 4FFFFH
SA5	1	0	1	50000H to 5FFFFH
SA6	1	1	0	60000H to 6FFFFH
SA7	1	1	1	70000H to 7FFFFH

Write

Device erasure and programming are accomplished via the command register. The contents of the register serve as inputs to the internal state machine. The state machine outputs dictate the function of the device.

The command register itself does not occupy any addressable memory location. The register is a latch used to store the commands, along with the address and data information needed to execute the command. The command register is written by bringing \overline{WE} to V_{IL}, while \overline{CE} is at V_{IL} and \overline{OE} is at V_{IH}. Addresses are latched on the falling edge of \overline{WE} or \overline{CE} , whichever happens later; while data is latched on the rising edge of \overline{WE} or \overline{CE} , whichever happens first. Standard microprocessor write timings are used.

Refer to AC Write Characteristics and the Erase/Programming Waveforms for specific timing parameters.

Sector Protection

The MBM29F040C features hardware sector protection. This feature will disable both program and erase operations in any number of sectors (0 through 8). The sector protection feature is enabled using programming equipment at the user's site. The device is shipped with all sectors unprotected.

To activate this mode, the programming equipment must force V_{ID} on address pin A₉ and control pin \overline{OE} , (suggest V_{ID} = 11.5 V) and $\overline{CE} = V_{IH}$. The sector addresses (A₁₈, A₁₇ and A₁₆) should be set to the sector to be protected. Table 4 defines the sector address for each of the eight (8) individual sectors. Programming of the protection circuitry begins on the falling edge of the \overline{WE} pulse and is terminated with the rising edge of the same. Sector addresses must be held constant during the \overline{WE} pulse. See figures 11 and 17 sector protection waveforms and algorithm.

To verify programming of the protection circuitry, the programming equipment must force V_{ID} on address pin A_9 with \overline{CE} and \overline{OE} at V_{IL} and \overline{WE} at V_{IH} . Scanning the sector addresses (A_{16} , A_{17} and A_{18}) while $(A_6, A_1, A_0) = (0, 1, 0)$ will produce a logical "1" code at device output DQ_0 for a protected sector. Otherwise the device will read 00H for unprotected sector. In this mode, the lower order addresses, except for A_0 , A_1 and A_6 are DON'T CARES. Address locations with $A_1 = V_{IL}$ are reserved for Autoselect manufacturer and device codes.

It is also possible to determine if a sector is protected in the system by writing an Autoselect command. Performing a read operation at the address location XX02H, where the higher order addresses (A_{16} , A_{17} and A_{18}) are the sector address will produce a logical "1" at DQ_0 for a protected sector. See Table 3 for Autoselect codes.

Table 5 MBM29F040C Command Definitions

Command Sequence Read/Reset	Bus Write Cycles Req'd	First Bus Write Cycle		Second Bus Write Cycle		Third Bus Write Cycle		Fourth Bus Read/Write Cycle		Fifth Bus Write Cycle		Sixth Bus Write Cycle	
		Addr	Data	Addr	Data	Addr	Data	Addr	Data	Addr	Data	Addr	Data
Read/Reset*	1	XXXH	F0H	—	—	—	—	—	—	—	—	—	—
Read/Reset*	4	555H	AAH	2AAH	55H	555H	F0H	RA	RD	—	—	—	—
Autoselect	3	555H	AAH	2AAH	55H	555H	90H	—	—	—	—	—	—
Byte Program	4	555H	AAH	2AAH	55H	555H	A0H	PA	PD	—	—	—	—
Chip Erase	6	555H	AAH	2AAH	55H	555H	80H	555H	AAH	2AAH	55H	555H	10H
Sector Erase	6	555H	AAH	2AAH	55H	555H	80H	555H	AAH	2AAH	55H	SA	30H
Sector Erase Suspend	Erase can be suspended during sector erase with Addr ("H" or "L"). Data (B0H)												
Sector Erase Resume	Erase can be resumed after suspend with Addr ("H" or "L"). Data (30H)												

- Notes:**
- Address bits A_{11} to $A_{18} = X = "H"$ or $"L"$ for all address commands except for Program Address (PA) and Sector Address (SA).
 - Bus operations are defined in Table 2.
 - RA = Address of the memory location to be read.
PA = Address of the memory location to be programmed. Addresses are latched on the falling edge of the \overline{WE} pulse.
SA = Address of the sector to be erased. The combination of A_{18} , A_{17} , and A_{16} will uniquely select any sector.
 - RD = Data read from location RA during read operation.
PD = Data to be programmed at location PA. Data is latched on the falling edge of \overline{WE} .

*: Either of the two reset commands will reset the device.

Command Definitions

Device operations are selected by writing specific address and data sequences into the command register. Writing incorrect address and data values or writing them in the improper sequence will reset the device to read mode. Table 5 defines the valid register command sequences. Note that the Erase Suspend (B0H) and Erase Resume (30H) commands are valid only while the Sector Erase operation is in progress. Moreover, both Read/Reset Commands are functionally equivalent, resetting the device to the read mode.

Read/Reset Command

The read or reset operation is initiated by writing the Read/Reset command sequence into the command register. Microprocessor read cycles retrieve array data from the memory. The device remains enabled for reads until the command register contents are altered.

The device will automatically power-up in the read/reset state. In this case, a command sequence is not required to read data. Standard microprocessor read cycles will retrieve array data. This default value ensures that no spurious alteration of the memory content occurs during the power transition. Refer to the AC Read Characteristics and Waveforms for the specific timing parameters.

Autoselect Command

Flash memories are intended for use in applications where the local CPU alters memory contents. As such, manufacture and device codes must be accessible while the device resides in the target system. PROM programmers typically access the signature codes by raising A_9 to a high voltage ($V_{ID} = 11.5\text{ V to }12.5$). However, multiplexing high voltage onto the address lines is not generally desired system design practice.

The device contains an Autoselect command operation to supplement traditional PROM programming methodology. The operation is initiated by writing the Autoselect command sequence into the command register. Following the command write, a read cycle from address XX00H retrieves the manufacture code of 04H. A read cycle from address XX01H returns the device code A4H. (see Table 3.) All manufacturer and device codes will exhibit odd parity with the MSB (DQ_7) defined as the parity bit.

Sector state (protection or unprotection) will be informed address XX02H.

Scanning the sector addresses (A_{16}, A_{17}, A_{18}) while (A_6, A_1, A_0) = (0, 1, 0) will produce a logical “1” at device output DQ_0 for a protected sector. The programming verification should be perform margin mode on the protected sector. (See Table 2 and 3.)

To terminate the operation, it is necessary to write the Read/Reset command sequence into the register, and also to write the Autoselect command during the operation, execute it after writing Read/Reset command sequence.

Byte Programming

The device is programmed on a byte-by-byte basis. Programming is a four bus cycle operation. There are two “unlock” write cycles. These are followed by the program setup command and data write cycles. Addresses are latched on the falling edge of \overline{CE} or \overline{WE} , whichever happens later and the data is latched on the rising edge of \overline{CE} or \overline{WE} , whichever happens first. The rising edge of \overline{CE} or \overline{WE} (whichever happens first) begins programming. Upon executing the Embedded Program Algorithm command sequence, the system is not required to provide further controls or timings. The device will automatically provide adequate internally generated program pulses and verify the programmed cell margin.

The automatic programming operation is completed when the data on DQ_7 is equivalent to data written to this bit (See Write Operation Status section.) at which time the device returns to the read mode and addresses are no longer latched. (See Table 6, Hardware Sequence Flags.) Therefore, the device requires that a valid address to the device be supplied by the system at this particular instance of time. Hence, Data Polling must be performed at the memory location which is being programmed.

Any commands written to the chip during this period will be ignored.

Programming is allowed in any sequence and across sector boundaries. Beware that a data “0” cannot be programmed back to a “1”. Attempting to do so may either hang up the device (Exceed timing limits.), or result in an apparent success according to the data polling algorithm but a read from reset/read mode will show that the data is still “0”. Only erase operations can convert “0”s to “1”s.

Figure 13 illustrates the Embedded Program™ Algorithm using typical command strings and bus operations.

Chip Erase

Chip erase is a six bus cycle operation. There are two “unlock” write cycles. These are followed by writing the “set-up” command. Two more “unlock” write cycles are then followed by the chip erase command.

Chip erase does not require the user to program the device prior to erase. Upon executing the Embedded Erase Algorithm command sequence the device will automatically program and verify the entire memory for an all zero data pattern prior to electrical erase. The system is not required to provide any controls or timings during these operations.

The automatic erase begins on the rising edge of the last \overline{WE} pulse in the command sequence and terminates when the data on DQ₇ is “1” (see Write Operation Status section.) at which time the device returns to read the mode.

Figure 14 illustrates the Embedded Erase Algorithm using typical command strings and bus operations.

Sector Erase

Sector erase is a six bus cycle operation. There are two “unlock” write cycles. These are followed by writing the “set-up” command. Two more “unlock” write cycles are then followed by the Sector Erase command. The sector address (Any address location within the desired sector.) is latched on the falling edge of \overline{WE} , while the command (Data = 30H) is latched on the rising edge of \overline{WE} . A time-out of 50 μ s from the rising edge of the last sector erase command will initiate the sector erase command(s).

Multiple sectors may be erased concurrently by writing the six bus cycle operations as described above. This sequence is followed with writes of the Sector Erase command to addresses in other sectors desired to be concurrently erased. The time between writes must be less than 50 μ s, otherwise that command will not be accepted. It is recommended that processor interrupts be disabled during this time to guarantee this condition. The interrupts can be re-enabled after the last Sector Erase command is written. A time-out of 50 μ s from the rising edge of the last \overline{WE} will initiate the execution of the Sector Erase command(s). If another falling edge of the \overline{WE} occurs within the 50 μ s time-out window the timer is reset. (Monitor DQ₃ to determine if the sector erase timer window is still open, see section DQ₃, Sector Erase Timer.) Any command other than Sector Erase or Erase Suspend during this time-out period will reset the device to read mode, ignoring the previous command string. Resetting the device once execution has begun will corrupt the data in the sector. In that case, restart the erase on those sectors and allow them to complete. (Refer to the Write Operation Status section for Sector Erase Timer operation.) Loading the sector erase buffer may be done in any sequence and with any number of sectors (1 to 7).

Sector erase does not require the user to program the device prior to erase. The device automatically programs all memory locations in the sector(s) to be erased prior to electrical erase. When erasing a sector or sectors the remaining unselected sectors are not affected. The system is not required to provide any controls or timings during these operations.

The automatic sector erase begins after the 50 μ s time out from the rising edge of the \overline{WE} pulse for the last sector erase command pulse and terminates when the data on DQ₇ is “1” (See Write Operation Status section.) at which time the device returns to read mode. During the execution of the Sector Erase command, only the Erase Suspend and Erase Resume commands are allowed. All other commands will reset the device to read mode. Data polling must be performed at an address within any of the sectors being erased.

Figure 14 illustrates the Embedded Erase™ Algorithm using typical command strings and bus operations.

Erase Suspend

The Erase Suspend command allows the user to interrupt a Sector Erase operation and then perform data reads from or programs to a sector not being erased. This command is applicable ONLY during the Sector Erase operation which include the time-out period for sector erase. The Erase Suspend command will be ignored if written during the Chip Erase operation or Embedded Program Algorithm. Writing the Erase Suspend command during the Sector Erase time-out results in immediate termination of the time-out period and suspension of the erase operation.

Any other command written during the Erase Suspend mode will be ignored except the Erase Resume command. Writing the Erase Resume command resumes the erase operation. The addresses are “DON'T CARES” when writing the Erase Suspend or Erase Resume command.

When the Erase Suspend command is written during the Sector Erase operation, the device will take a maximum of 10 μ s to suspend the erase operation. When the devices have entered the erase-suspended mode, the DQ₇ bit will be at logic “1”, and DQ₆ will stop toggling. The user must use the address of the erasing sector for reading DQ₆ and DQ₇ to determine if the erase operation has been suspended. Further writes of the Erase Suspend command are ignored.

When the erase operation has been suspended, the devices default to the erase-suspend-read mode. Reading data in this mode is the same as reading from the standard read mode except that the data must be read from sectors that have not been erase-suspended. Successively reading from the erase-suspended sector while the device is in the erase-suspend-read mode will cause DQ₂ to toggle. (See the section on DQ₂.)

After entering the erase-suspend-read mode, the user can program the device by writing the appropriate command sequence for Program. This Program mode is known as the erase-suspend-program mode. Again, programming in this mode is the same as programming in the regular Program mode except that the data must be programmed to sectors that are not erase-suspended. Successively reading from the erase-suspended sector while the devices are in the erase-suspend-program mode will cause DQ₂ to toggle. The end of the erase-suspended Program operation is detected by $\overline{\text{Data}}$ polling of DQ₇, or by the Toggle Bit I (DQ₆) which is the same as the regular Program operation. Note that DQ₇ must be read from the Program address while DQ₆ can be read from any address.

To resume the operation of Sector Erase, the Resume command (30H) should be written. Any further writes of the Resume command at this point will be ignored. Another Erase Suspend command can be written after the chip has resumed erasing.

Write Operation Status

Table 6 Hardware Sequence Flags

Status		DQ ₇	DQ ₆	DQ ₅	DQ ₃	DQ ₂	
In Progress	Embedded Program Algorithm	\overline{DQ}_7	Toggle	0	0	1	
	Embedded Erase Algorithm	0	Toggle	0	1	Toggle	
	Erase Suspended Mode	Erase Suspend Read (Erase Suspended Sector)	1	1	0	0	Toggle
		Erase Suspend Read (Non-Erase Suspended Sector)	Data	Data	Data	Data	Data
	Erase Suspend Program (Non-Erase Suspended Sector)	\overline{DQ}_7	Toggle (Note 1)	0	0	1 (Note 2)	
Exceeded Time Limits	Embedded Program Algorithm	\overline{DQ}_7	Toggle	1	0	1	
	Program/Erase in Embedded Erase Algorithm	0	Toggle	1	1	N/A	
	Erase Suspended Mode	Erase Suspend Program (Non-Erase Suspended Sector)	\overline{DQ}_7	Toggle	1	0	N/A

- Notes:**
1. Performing successive read operations from any address will cause DQ₆ to toggle.
 2. Reading the byte address being programmed while in the erase-suspend program mode will indicate logic "1" at the DQ₂ bit. However, successive reads from the erase-suspended sector will cause DQ₂ to toggle.
 3. DQ₀ and DQ₁ are reserve pins for future use. DQ₄ is for Fujitsu internal use only.

DQ₇

Data Polling

The MBM29F040C device features \overline{Data} Polling as a method to indicate to the host that the Embedded Algorithms are in progress or completed. During the Embedded Program Algorithm an attempt to read the device will produce the compliment of the data last written to DQ₇. Upon completion of the Embedded Program Algorithm, an attempt to read the device will produce the true data last written to DQ₇. During the Embedded Erase Algorithm, an attempt to read the device will produce a "0" at the DQ₇ output. Upon completion of the Embedded Erase Algorithm an attempt to read the device will produce a "1" at the DQ₇ output. The flowchart for \overline{Data} Polling (DQ₇) is shown in Figure 15.

For chip erase, and sector erase the \overline{Data} Polling is valid after the rising edge of the sixth \overline{WE} pulse in the six write pulse sequence. For sector erase, the \overline{Data} Polling is valid after the last rising edge of the sector erase \overline{WE} pulse. \overline{Data} Polling must be performed at sector address within any of the sectors being erased and not a protected sector. Otherwise, the status may not be valid. Once the Embedded Algorithm operation is close to being completed, the MBM29F040C data pins (DQ₇) may change asynchronously while the output enable (\overline{OE}) is asserted low. This means that the device is driving status information on DQ₇ at one instant of time and then that byte's valid data at the next instant of time. Depending on when the system samples the DQ₇ output, it may read the status or valid data. Even if the device has completed the Embedded Algorithm operation and DQ₇ has a valid data, the data outputs on DQ₀ to DQ₆ may be still invalid. The valid data on DQ₀ to DQ₇ will be read on the successive read attempts.

The \overline{Data} Polling feature is only active during the Embedded Programming Algorithm, Embedded Erase Algorithm, or sector erase time-out. (See Table 6.)

See Figure 9 for the \overline{Data} Polling timing specifications and diagrams.

DQ₆

Toggle Bit I

The MBM29F040C also features the “Toggle Bit I” as a method to indicate to the host system that the Embedded Algorithms are in progress or completed.

During an Embedded Program or Erase Algorithm cycle, successive attempts to read (\overline{OE} toggling) data from the device will result in DQ₆ toggling between one and zero. Once the Embedded Program or Erase Algorithm cycle is completed, DQ₆ will stop toggling and valid data will be read on the next successive attempts. During programming, the Toggle Bit I is valid after the rising edge of the fourth \overline{WE} pulse in the four write pulse sequence. For chip erase and sector erase, the Toggle Bit I is valid after the rising edge of the sixth \overline{WE} pulse in the six write pulse sequence. The Toggle Bit I is active during the sector time out.

In programming, if the sector being written to is protected, the toggle bit will toggle for about 2 μ s and then stop toggling without the data having changed. In erase, the device will erase all the selected sectors except for the ones that are protected. If all selected sectors are protected, the chip will toggle the toggle bit for about 100 μ s and then drop back into read mode, having changed none of the data.

Either \overline{CE} or \overline{OE} toggling will cause the DQ₆ to toggle. In addition, an Erase Suspend/Resume command will cause the DQ₆ to toggle.

See Figure 10 for the Toggle Bit timing specifications and diagrams.

DQ₅

Exceeded Timing Limits

DQ₅ will indicate if the program or erase time has exceeded the specified limits (internal pulse count). Under these conditions DQ₅ will produce a “1”. This is a failure condition which indicates that the program or erase cycle was not successfully completed. $\overline{\text{Data Polling DQ}_7}$, DQ₆ is the only operating function of the device under this condition. The \overline{CE} circuit will partially power down the device under these conditions (to approximately 2 mA). The \overline{OE} and \overline{WE} pins will control the output disable functions as described in Table 2.

The DQ₅ failure condition may also appear if a user tries to program a non blank location without erasing. In this case the device locks out and never completes the Embedded Algorithm operation. Hence, the system never reads a valid data on DQ₇ bit and DQ₆ never stops toggling. Once the device has exceeded timing limits, the DQ₅ bit will indicate a “1.” Please note that this is not a device failure condition since the device was incorrectly used. If this occurs, reset the device with command sequence.

DQ₃

Sector Erase Timer

After the completion of the initial sector erase command sequence the sector erase time-out will begin. DQ₃ will remain low until the time-out is complete. $\overline{\text{Data Polling}}$ and Toggle Bit I are valid after the initial sector erase command sequence.

If $\overline{\text{Data Polling}}$ or the Toggle Bit I indicates the device has been written with a valid erase command. DQ₃ may be used to determine if the sector erase timer window is still open. If DQ₃ is high (“1”) the internally controlled erase cycle has begun; attempts to write subsequent commands to the device will be ignored until the erase operation is completed as indicated by $\overline{\text{Data Polling}}$ or Toggle Bit I. If DQ₃ is low (“0”), the device will accept additional sector erase commands. To insure the command has been accepted, the system software should check the status of DQ₃ prior to and following each subsequent sector erase command. If DQ₃ were high on the second status check, the command may not have been accepted.

Refer to Table 6: Hardware Sequence Flags.

DQ₂

Toggle Bit II

This Toggle Bit II, along with DQ₆, can be used to determine whether the devices are in the Embedded Erase Algorithm or in Erase Suspend.

Successive reads from the erasing sector will cause DQ₂ to toggle during the Embedded Erase Algorithm. If the devices are in the erase-suspended-read mode, successive reads from the erase-suspended sector will cause DQ₂ to toggle. When the devices are in the erase-suspended-program mode, successive reads from the byte address of the non-erase suspended sector will indicate a logic “1” at the DQ₂ bit.

DQ₆ is different from DQ₂ in that DQ₆ toggles only when the standard program or Erase, or Erase Suspend Program operation is in progress. The behavior of these two status bits, along with that of DQ₇, is summarized as follows:

Mode	DQ ₇	DQ ₆	DQ ₂
Program	$\overline{DQ_7}$	toggles	1
Erase	0	toggles	toggles
Erase Suspend Read (Erase-Suspended Sector) (Note 1)	1	1	toggles
Erase Suspend Program	$\overline{DQ_7}$ (Note 2)	toggles	1 (Note 2)

- Notes:** 1. These status flags apply when outputs are read from a sector that has been erase-suspended.
 2. These status flags apply when outputs are read from the byte address of the non-erase suspended sector.

Data Protection

The MBM29F040C is designed to offer protection against accidental erasure or programming caused by spurious system level signals that may exist during power transitions. During power up the device automatically resets the internal state machine in the Read mode. Also, with its control register architecture, alteration of the memory contents only occurs after successful completion of specific multi-bus cycle command sequences.

The device also incorporates several features to prevent inadvertent write cycles resulting from V_{CC} power-up and power-down transitions or system noise.

Low V_{CC} Write Inhibit

To avoid initiation of a write cycle during V_{CC} power-up and power-down, a write cycle is locked out for V_{CC} less than 3.2 V (typically 3.7 V). If V_{CC} < V_{LKO}, the command register is disabled and all internal program/erase circuits are disabled. Under this condition the device will reset to the read mode. Subsequent writes will be ignored until the V_{CC} level is greater than V_{LKO}.

Write Pulse “Glitch” Protection

Noise pulses of less than 5 ns (typical) on \overline{OE} , \overline{CE} , or \overline{WE} will not initiate a write cycle.

Logical Inhibit

Writing is inhibited by holding any one of $\overline{OE} = V_{IL}$, $\overline{CE} = V_{IH}$, or $\overline{WE} = V_{IH}$. To initiate a write cycle \overline{CE} and \overline{WE} must be a logical zero while \overline{OE} is a logical one.

Power-Up Write Inhibit

Power-up of the device with $\overline{WE} = \overline{CE} = V_{IL}$ and $\overline{OE} = V_{IH}$ will not accept commands on the rising edge of \overline{WE} . The internal state machine is automatically reset to the read mode on power-up.

■ ABSOLUTE MAXIMUM RATINGS

Storage Temperature	-55°C to +125°C
Ambient Temperature with Power Applied	-40°C to +85°C
Voltage with Respect to Ground All pins except A ₉ , \overline{OE} (Note 1).....	-2.0 V to +7.0 V
V _{CC} (Note 1)	-2.0 V to +7.0 V
A ₉ , \overline{OE} (Note 2)	-2.0 V to +13.5 V

- Notes:** 1. Minimum DC voltage on input or I/O pins is -0.5 V. During voltage transitions, inputs may negative overshoot V_{SS} to -2.0 V for periods of up to 20 ns. Maximum DC voltage on output and I/O pins is V_{CC} +0.5 V. During voltage transitions, outputs may positive overshoot to V_{CC} +2.0 V for periods of up to 20 ns.
2. Minimum DC input voltage on A₉ and \overline{OE} pins are -0.5 V. During voltage transitions, A₉ and \overline{OE} pins may negative overshoot V_{SS} to -2.0 V for periods of up to 20 ns. Maximum DC input voltage on A₉ and \overline{OE} pins are +13.5 V which may overshoot to 14.0 V for periods of up to 20 ns.

WARNING: Semiconductor devices can be permanently damaged by application of stress (voltage, current, temperature, etc.) in excess of absolute maximum ratings. Do not exceed these ratings.

■ RECOMMENDED OPERATING RANGES

Ambient Temperature (T _A)	-40°C to +85°C
V _{CC} Supply Voltages	
MBM29F040C-55.....	+4.75 V to +5.25 V
MBM29F040C-70/-90	+4.50 V to +5.50 V

Operating ranges define those limits between which the functionality of the device is guaranteed.

WARNING: The recommended operating conditions are required in order to ensure normal operation of the semiconductor device. All of the device's electrical characteristics are warranted when the device is operated within these ranges.

Always use semiconductor devices within their recommended operating condition ranges. Operation outside these ranges may adversely affect reliability and could result in device failure.

No warranty is made with respect to uses, operating conditions, or combinations not represented on the data sheet. Users considering application outside the listed conditions are advised to contact their FUJITSU representatives beforehand.

■ MAXIMUM OVERSHOOT

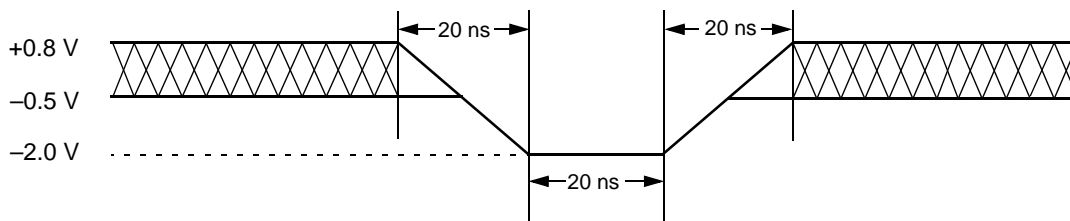

Figure 1 Maximum Negative Overshoot Waveform

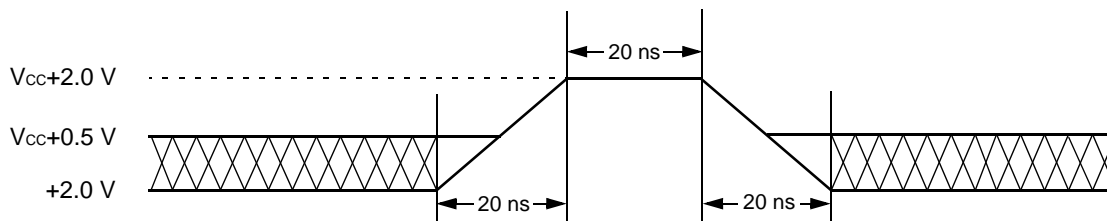
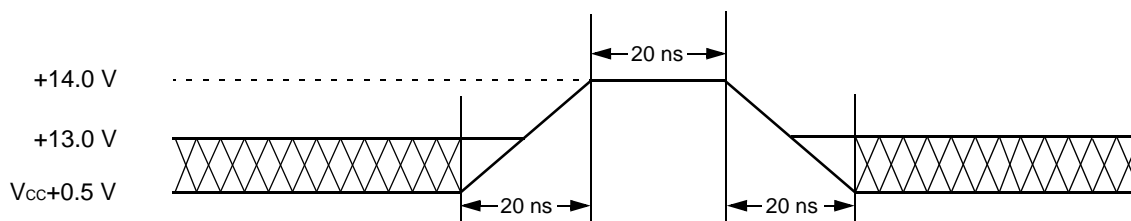

Figure 2 Maximum Positive Overshoot Waveform 1



* : This waveform is applied for A_9 , \overline{OE} .

Figure 3 Maximum Positive Overshoot Waveform 2

■ DC CHARACTERISTICS

Parameter Symbol	Parameter Description	Test Conditions	Min.	Max.	Unit
I _{LI}	Input Leakage Current	V _{IN} = V _{SS} to V _{CC} , V _{CC} = V _{CC} Max	—	±1.0	μA
I _{LO}	Output Leakage Current	V _{OUT} = V _{SS} to V _{CC} , V _{CC} = V _{CC} Max	—	±1.0	μA
I _{LIT}	A ₉ , \overline{OE} Input Leakage Current	V _{CC} = V _{CC} Max., A ₉ , \overline{OE} = 12.0 V	—	50	μA
I _{CC1}	V _{CC} Active Current (Note 1)	\overline{CE} = V _{IL} , \overline{OE} = V _{IH}	—	30	mA
I _{CC2}	V _{CC} Active Current (Note 2)	\overline{CE} = V _{IL} , \overline{OE} = V _{IH}	—	45	mA
I _{CC3}	V _{CC} Current (Standby)	V _{CC} = V _{CC} Max., \overline{CE} = V _{IH}	—	1	mA
		V _{CC} = V _{CC} Max., \overline{CE} = V _{CC} ±0.3 V	—	5	μA
V _{IL}	Input Low Level	—	-0.5	0.8	V
V _{IH}	Input High Level	—	2.0	V _{CC} +0.3	V
V _{ID}	Voltage for Autoselect and Sector Protection (A ₉ , \overline{OE}) (Note 3, 4)	V _{CC} = 5.0 V	11.5	12.5	V
V _{OL}	Output Low Voltage Level	I _{OL} = 12.0 mA, V _{CC} = V _{CC} Min	—	0.45	V
V _{OH1}	Output High Voltage Level	I _{OH} = -2.5 mA, V _{CC} = V _{CC} Min	2.4	—	V
V _{OH2}		I _{OH} = -100 μA	V _{CC} -0.4	—	V
V _{LKO}	Low V _{CC} Lock-Out Voltage	—	3.2	4.2	V

- Notes:**
1. The I_{CC} current listed includes both the DC operating current and the frequency dependent component (at 6 MHz). The frequency component typically is 2 mA/MHz, with \overline{OE} at V_{IH}.
 2. I_{CC} active while Embedded Algorithm (program or erase) is in progress.
 3. Applicable to sector protection function.
 4. (V_{ID} - V_{CC}) do not exceed 9 V.

AC CHARACTERISTICS

Read Only Operations Characteristics

Parameter Symbols		Description	Test Setup		-55 (Note1)	-70 (Note2)	-90 (Note2)	Unit
JEDEC	Standard							
t _{AVAV}	t _{RC}	Read Cycle Time	—	Min.	55	70	90	ns
t _{AVQV}	t _{ACC}	Address to Output Delay	$\overline{CE} = V_{IL}$ $\overline{OE} = V_{IL}$	Max.	55	70	90	ns
t _{ELQV}	t _{CE}	Chip Enable to Output Delay	$\overline{OE} = V_{IL}$	Max.	55	70	90	ns
t _{GLQV}	t _{OE}	Output Enable to Output Delay	—	Max.	30	30	35	ns
t _{EHQZ}	t _{DF}	Chip Enable to Output HIGH-Z	—	Max.	20	20	20	ns
t _{GHQZ}	t _{DF}	Output Enable to Output HIGH-Z	—	Max.	20	20	20	ns
t _{AXQX}	t _{OH}	Output Hold Time From Addresses, \overline{CE} or \overline{OE} , Whichever Occurs First	—	Min.	0	0	0	ns

Note: 1. Test Conditions:
 Output Load: 1 TTL gate and 30 pF
 Input rise and fall times: 5 ns
 Input pulse levels: 0.0 V to 3.0 V
 Timing measurement reference level
 Input: 1.5 V
 Output: 1.5 V

Note: 2. Test Conditions:
 Opout Load: 1 TTL gate and 100 pF
 Input rise and fall times: 5 ns
 Input pulse levels: 0.45 V to 2.4 V
 Timing measurement reference level
 Input: 0.8 and 2.0 V
 Output: 0.8 and 2.0 V

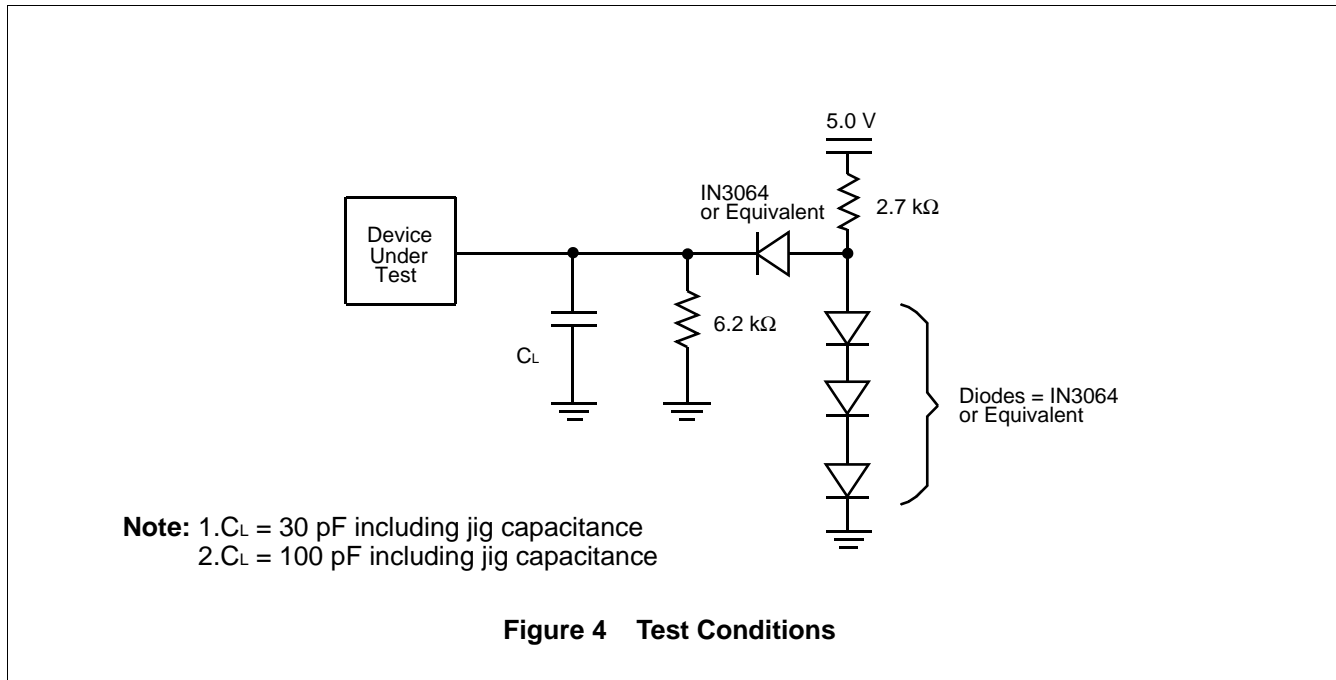

• Write/Erase/Program Operations

Parameter Symbols		Description		MBM29F040C			Unit
JEDEC	Standard			-55	-70	-90	
t _{AVAV}	t _{WC}	Write Cycle Time	Min.	55	70	90	ns
t _{AVWL}	t _{AS}	Address Setup Time	Min.	0	0	0	ns
t _{WLAX}	t _{AH}	Address Hold Time	Min.	40	45	45	ns
t _{DVWH}	t _{DS}	Data Setup Time	Min.	25	30	45	ns
t _{WHDX}	t _{DH}	Data Hold Time	Min.	0	0	0	ns
—	t _{OES}	Output Enable Setup Time	Min.	0	0	0	ns
—	t _{OEH}	Output Enable Hold Time	Min.	0	0	0	ns
		Read Toggle and $\overline{\text{Data}}$ Polling	Min.	10	10	10	ns
t _{GHWL}	t _{GHWL}	Read Recover Time Before Write	Min.	0	0	0	ns
t _{GHEL}	t _{GHEL}	Read Recover Time Before Write	Min.	0	0	0	ns
t _{ELWL}	t _{CS}	$\overline{\text{CE}}$ Setup Time	Min.	0	0	0	ns
t _{WLEL}	t _{WS}	$\overline{\text{WE}}$ Setup Time	Min.	0	0	0	ns
t _{WHEH}	t _{CH}	$\overline{\text{CE}}$ Hold Time	Min.	0	0	0	ns
t _{EHWH}	t _{WH}	$\overline{\text{WE}}$ Hold Time	Min.	0	0	0	ns
t _{WLWH}	t _{WP}	Write Pulse Width	Min.	30	35	45	ns
t _{ELEH}	t _{CP}	$\overline{\text{CE}}$ Pulse Width	Min.	30	35	45	ns
t _{WHWL}	t _{WPH}	Write Pulse Width High	Min.	20	20	20	ns
t _{EHEL}	t _{CPH}	$\overline{\text{CE}}$ Pulse Width High	Min.	20	20	20	ns
t _{WHWH1}	t _{WHWH1}	Byte Programming Operation	Typ.	8	8	8	μs
t _{WHWH2}	t _{WHWH2}	Sector Erase Operation (Note 1)	Typ.	1	1	1	sec
			Max.	8	8	8	sec
—	t _{VCS}	V _{CC} Setup Time	Min.	50	50	50	μs
—	t _{VLHT}	Voltage Transition Time (Notes 2)	Min.	4	4	4	μs
—	t _{WPP}	Write Pulse Width (Note 2)	Min.	100	100	100	μs
—	t _{OESP}	$\overline{\text{OE}}$ Setup Time to $\overline{\text{WE}}$ Active (Note 2)	Min.	4	4	4	μs
—	t _{CSP}	$\overline{\text{CE}}$ Setup Time to $\overline{\text{WE}}$ Active (Note 2)	Min.	4	4	4	μs
—	t _{EOE}	Delay Time from Embedded Output Enable	Max.	30	30	35	ns

Notes: 1. This does not include the preprogramming time.
 2. This timing is only for Sector Protect operations.

SWITCHING WAVEFORMS

Key to Switching Waveforms

WAVEFORM	INPUTS	OUTPUTS
	Must Be Steady	Will Be Steady
	May Change from H to L	Will Be Changing from H to L
	May Change from L to H	Will Be Changing from L to H
	"H" or "L" Any Change Permitted	Changing State Unknown
	Does Not Apply	Center Line is High-Impedance "Off" State

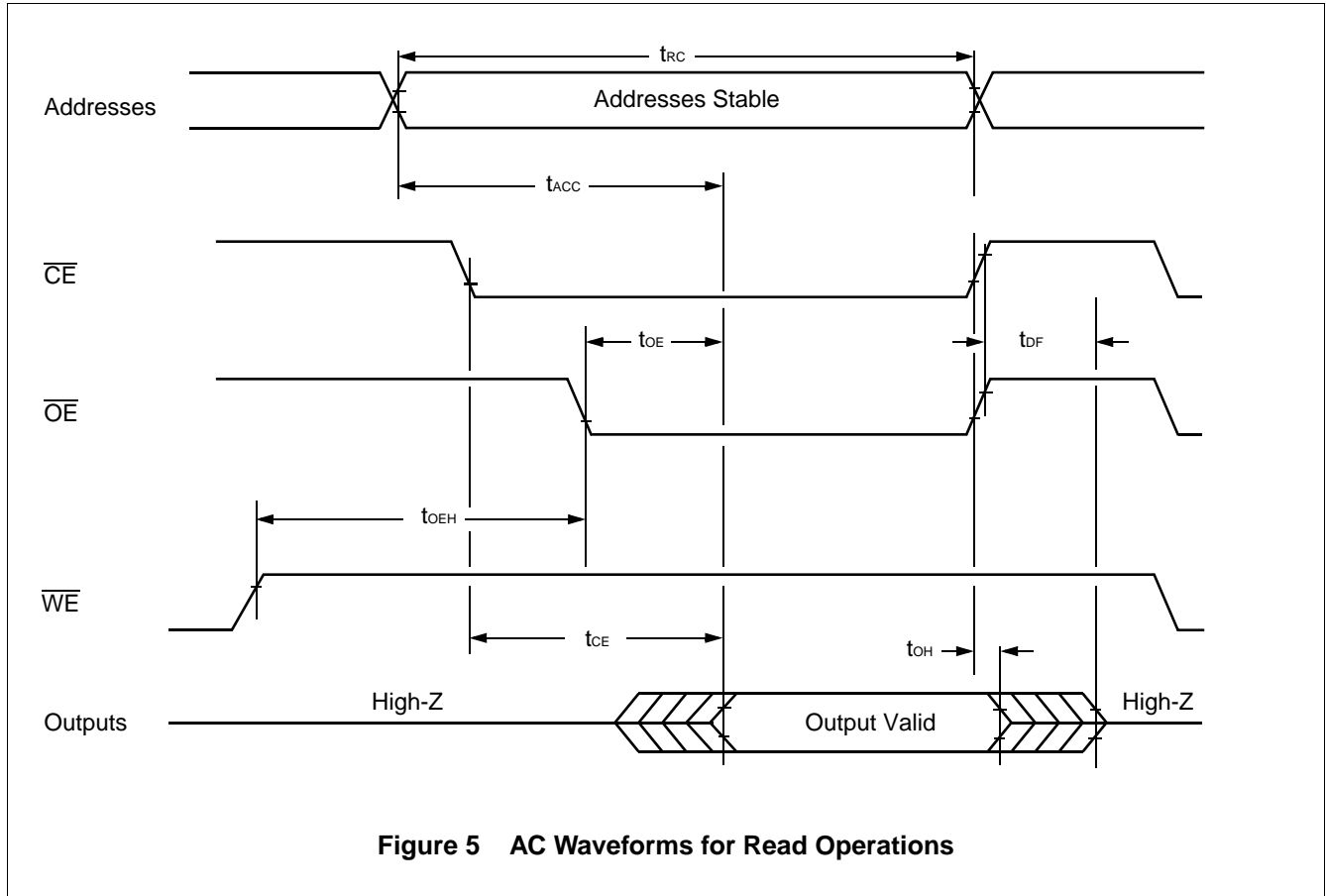

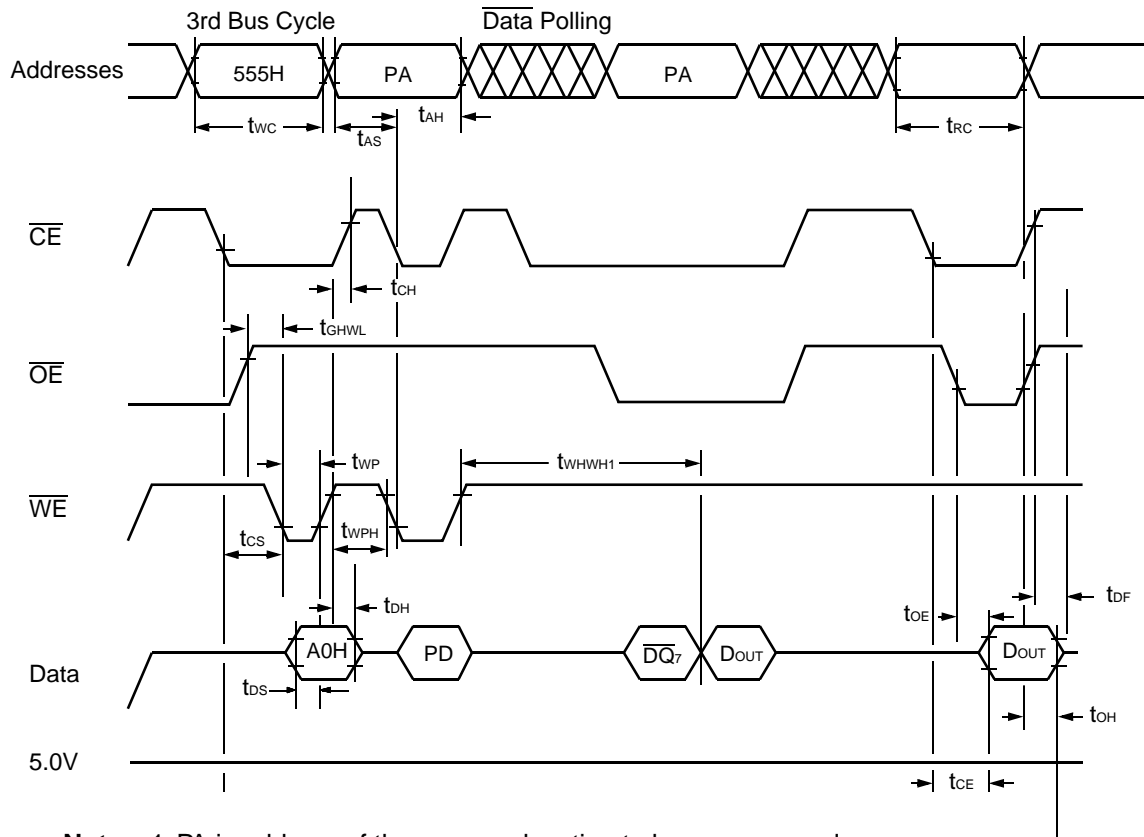

- Notes:**
1. PA is address of the memory location to be programmed.
 2. PD is data to be programmed at byte address.
 3. \overline{DQ}_7 is the output of the complement of the data written to the device.
 4. D_{OUT} is the output of the data written to the device.
 5. Figure indicates last two bus cycles of four bus cycle sequence.

Figure 6 AC Waveforms for Alternate \overline{WE} Controlled Program Operations

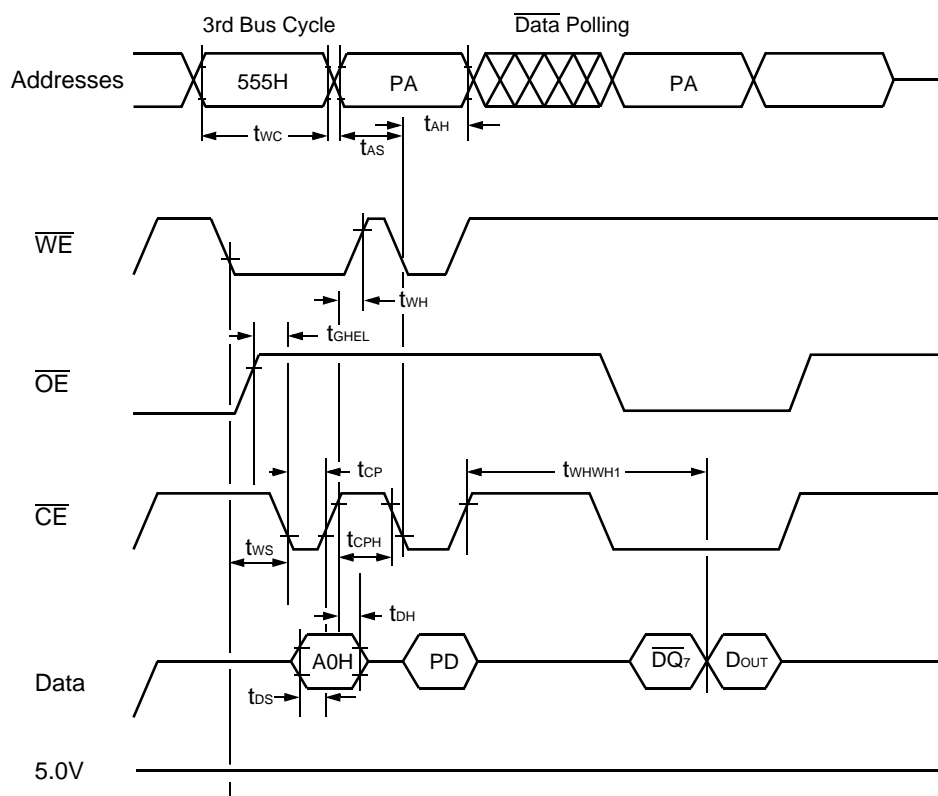

- Notes:**
1. PA is address of the memory location to be programmed.
 2. PD is data to be programmed at byte address.
 3. \overline{DQ}_7 is the output of the complement of the data written to the device.
 4. D_{OUT} is the output of the data written to the device.
 5. Figure indicates last two bus cycles of four bus cycle sequence.

Figure 7 AC Waveforms for Alternate \overline{CE} Controlled Program Operations

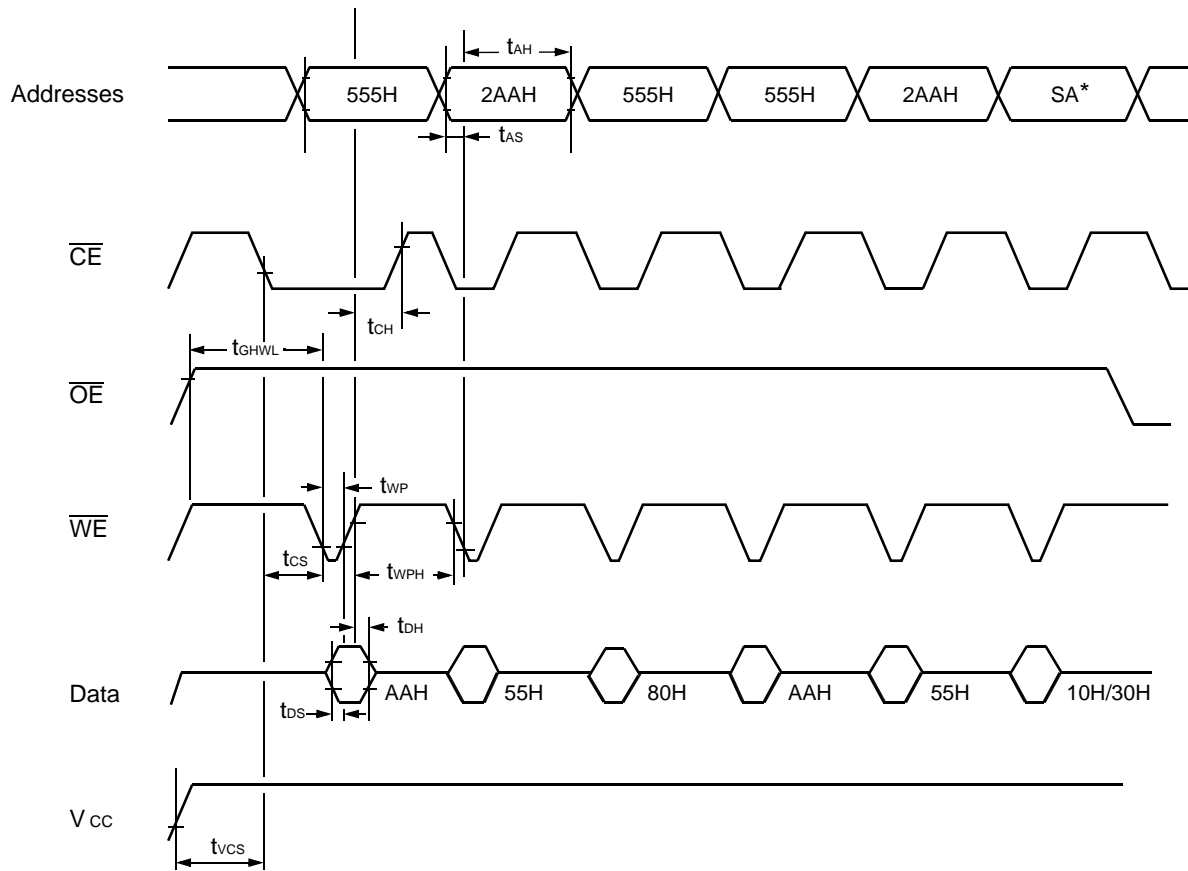

* : SA is the sector address for Sector Erase. Addresses = 555H for Chip Erase

Figure 8 AC Waveforms Chip/Sector Erase Operations

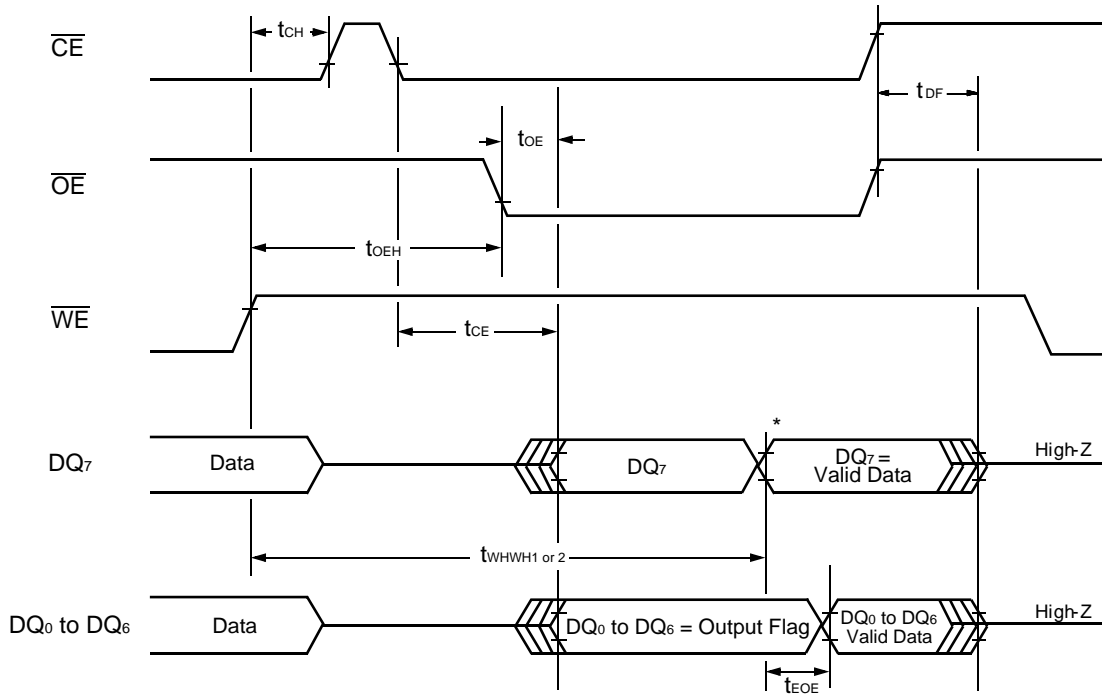

* : DQ₇ = Valid Data (The device has completed the Embedded operation.)

Figure 9 AC Waveforms for Data Polling during Embedded Algorithm Operations

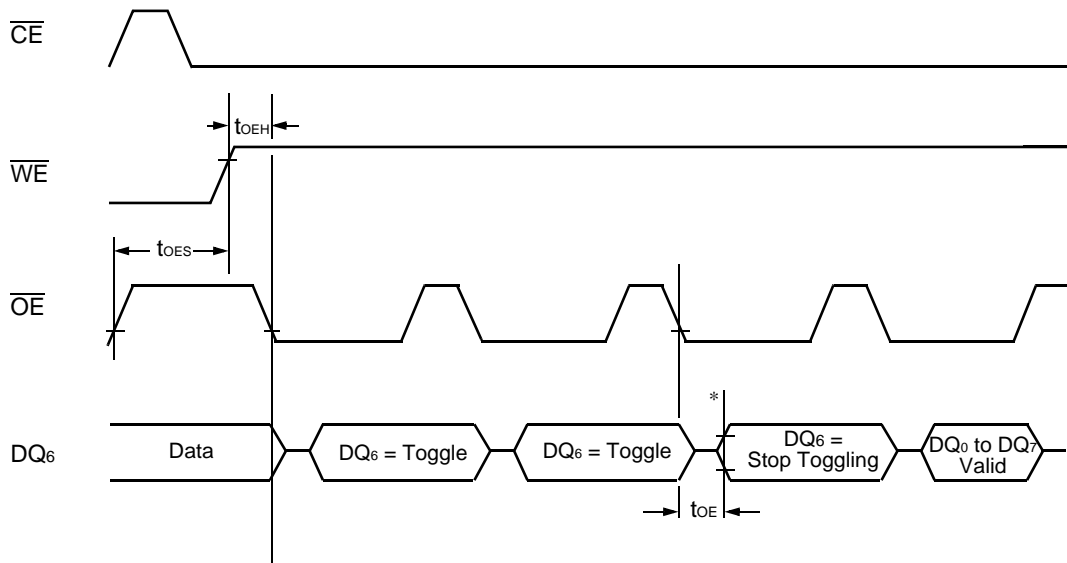

* : DQ₆ stops toggling (The device has completed the Embedded operation).

Figure 10 AC Waveforms for Toggle Bit I during Embedded Algorithm Operations

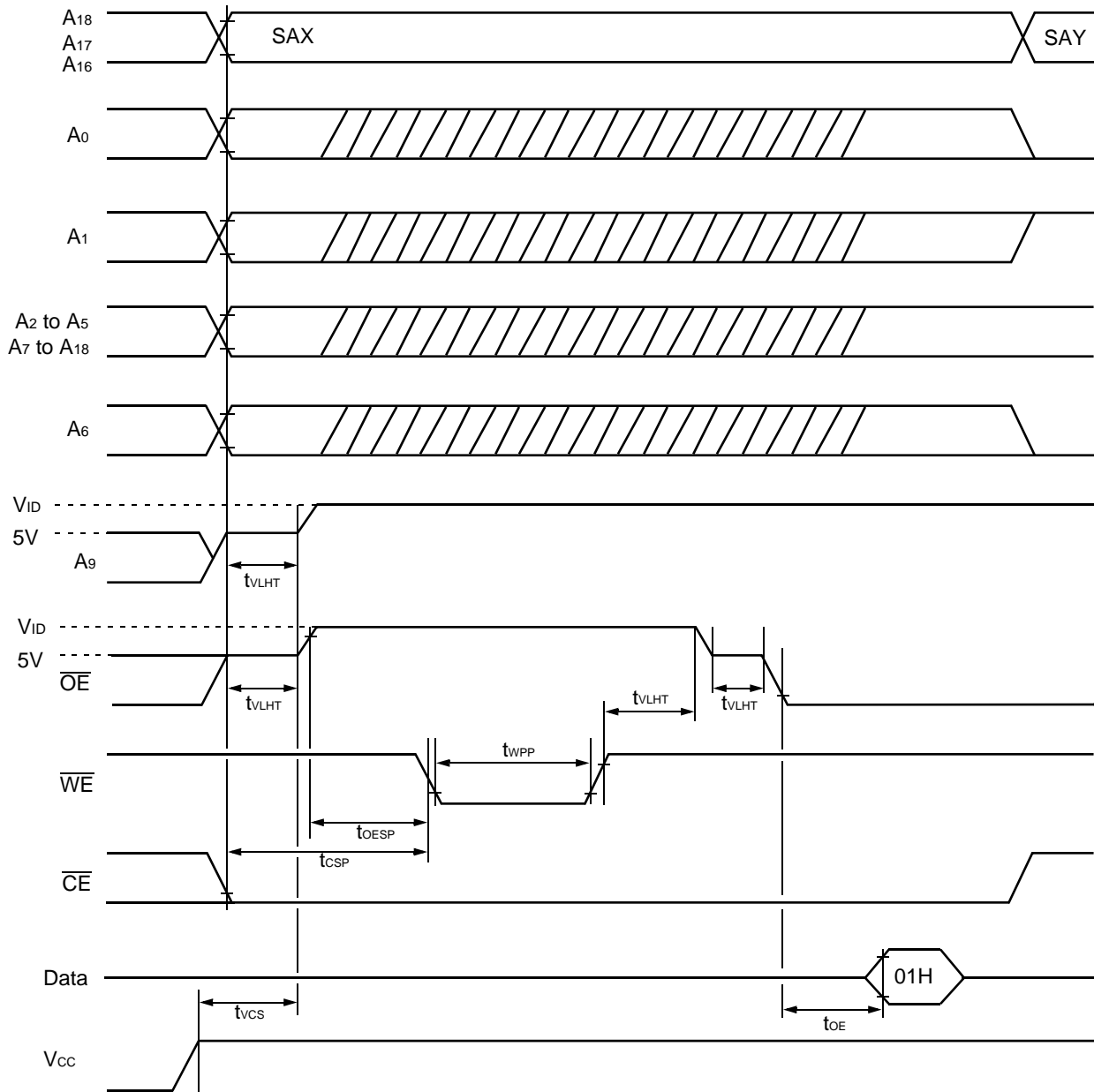

SAX : Sector Address for initial sector
 SAY : Sector Address for next sector

Figure 11 AC Waveforms for Sector Protection Timing Diagram

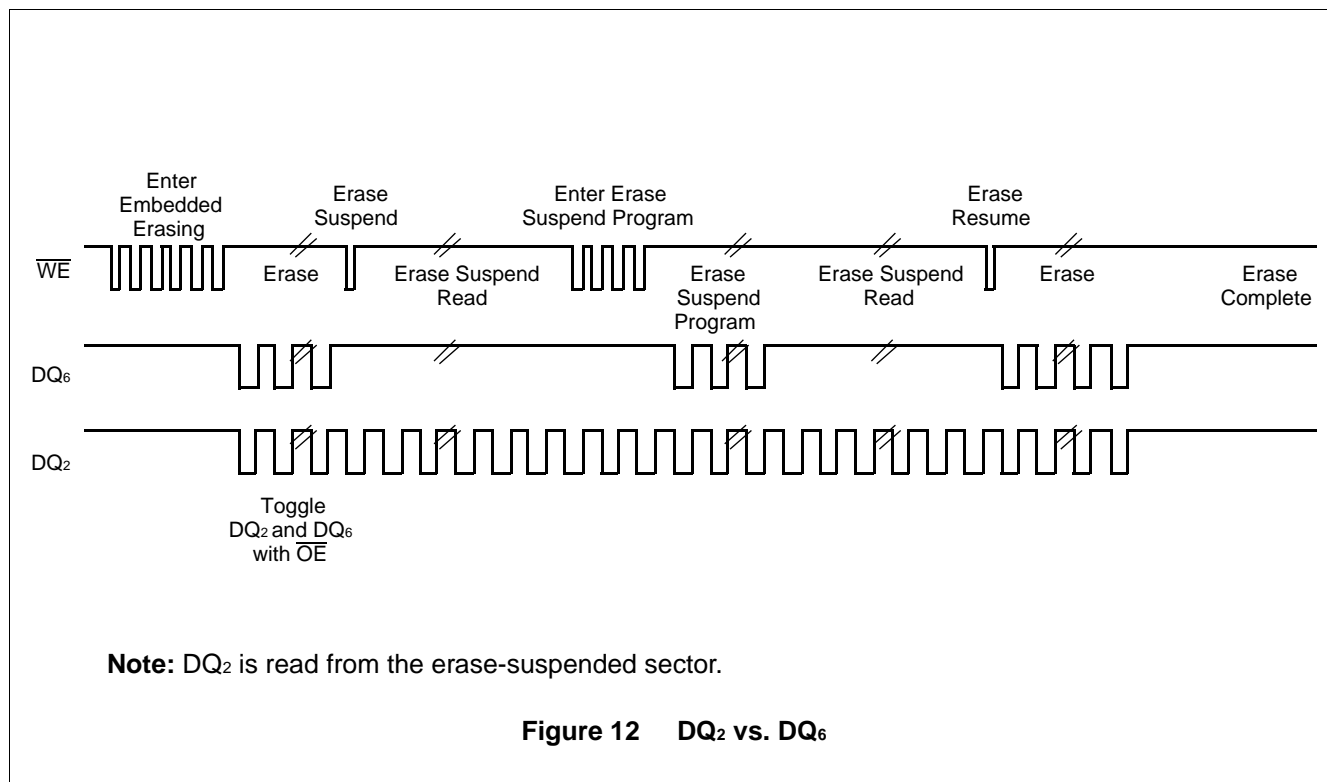

EMBEDDED ALGORITHMS

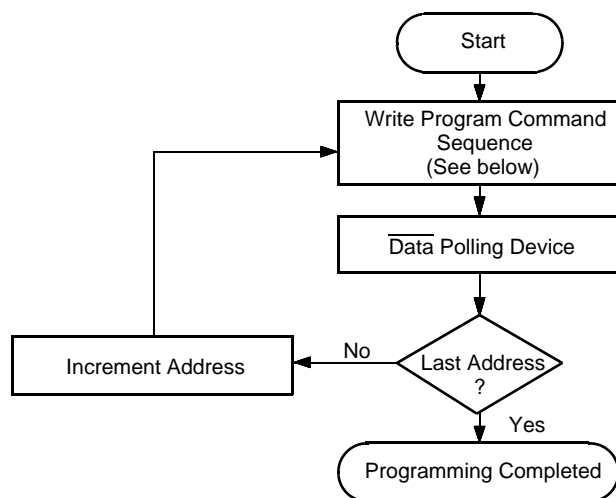

Program Command Sequence (Address/Command)

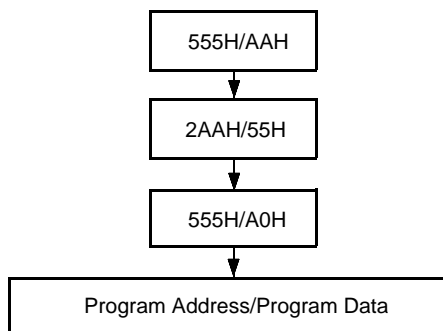

Figure 13 Embedded Program™ Algorithm

EMBEDDED ALGORITHMS

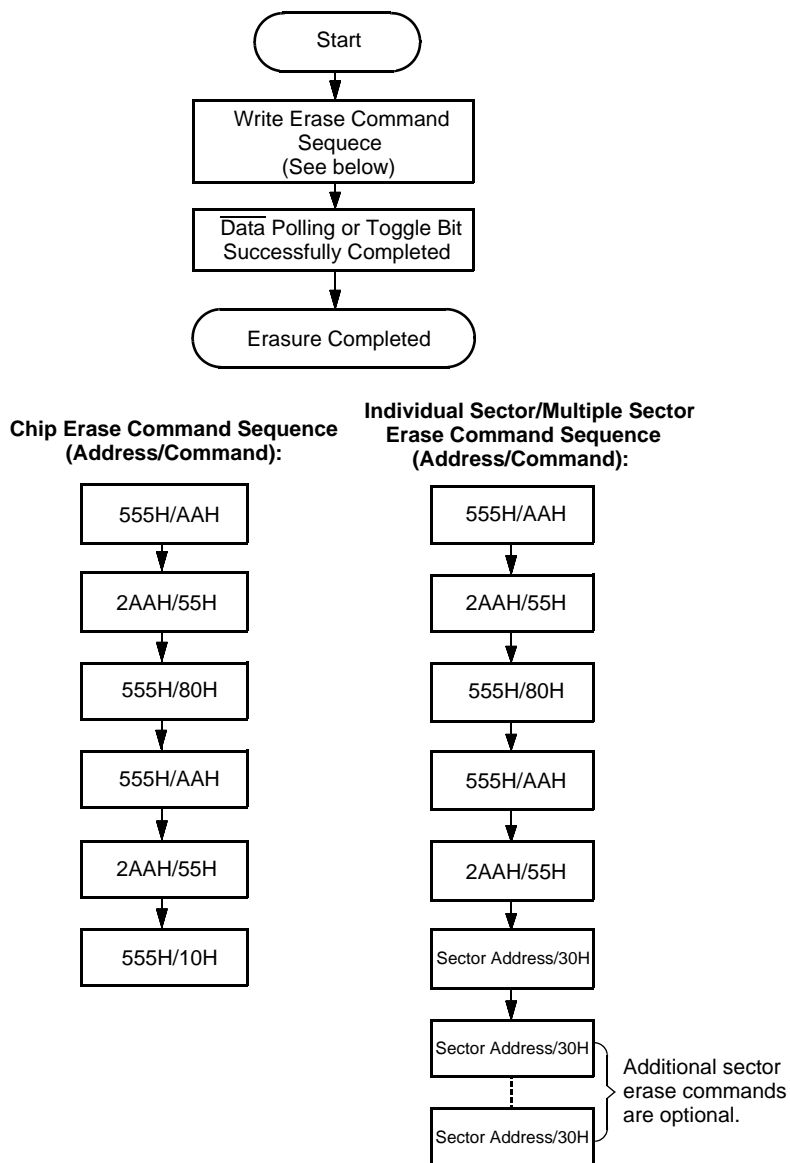
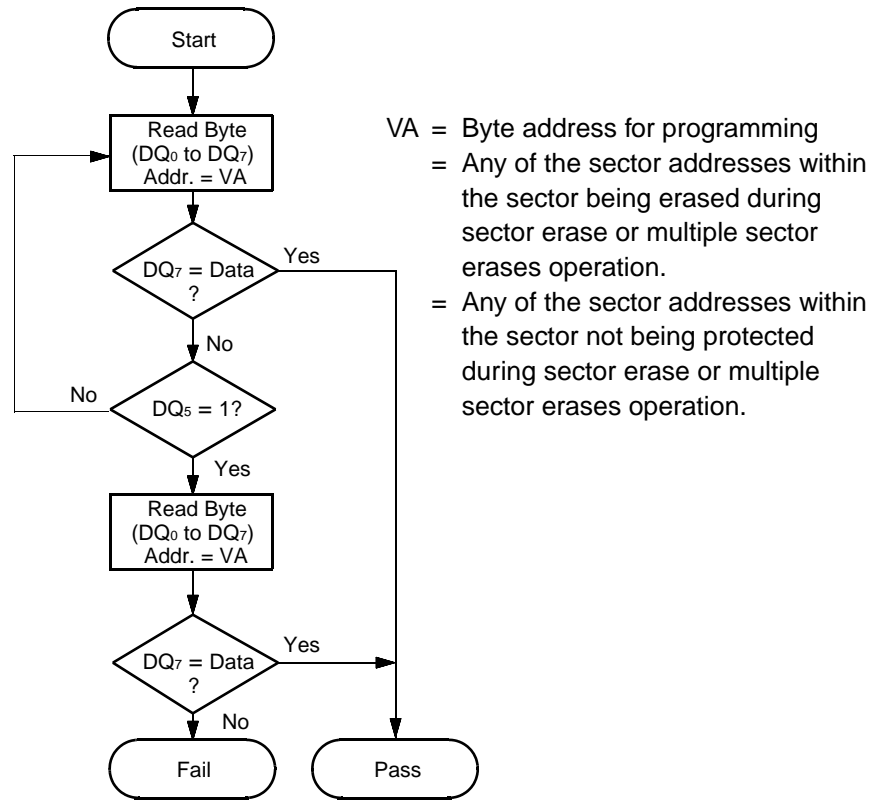
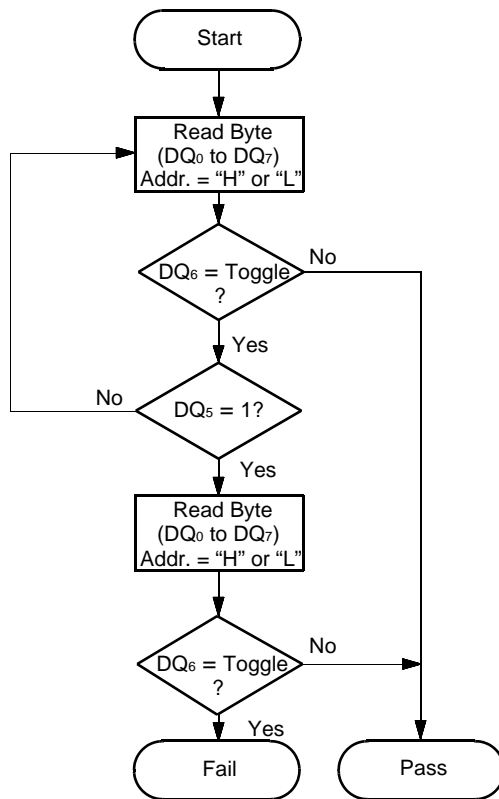

Figure 4 Embedded Erase™ Algorithm



Note: DQ₇ is rechecked even if DQ₅ = "1" because DQ₇ may change simultaneously with DQ₅.

Figure 5 Data Polling Algorithm



Note: DQ₆ is rechecked even if DQ₅ = "1" because DQ₆ may stop toggling at the same time as DQ₅ changing to "1".

Figure 6 Toggle Bit Algorithm

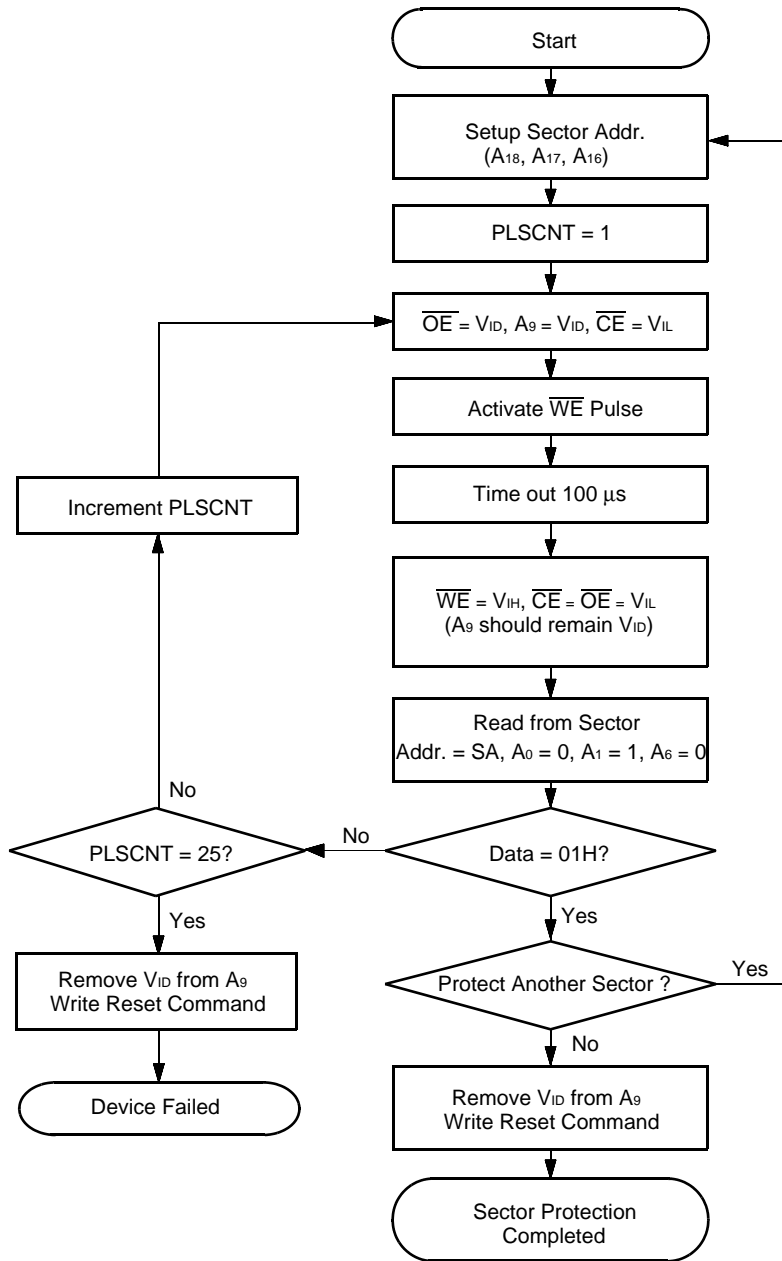

Figure 7 Sector Protection Algorithm

■ ERASE AND PROGRAMMING PERFORMANCE

Parameter	Limits			Unit	Comments
	Min.	Typ.	Max.		
Sector Erase Time	—	1	8	sec	Excludes 00H programming prior to erasure
Byte Programming Time	—	8	150	μs	Excludes system-level overhead
Chip Programming Time	—	4.2	10	sec	Excludes system-level overhead
Erase/Program Cycle	100,000	—	—	cycles	

■ TSOP(I) PIN CAPACITANCE

Parameter Symbol	Parameter Description	Test Setup	Typ.	Max.	Unit
C _{IN}	Input Capacitance	V _{IN} = 0	7	8	pF
C _{OUT}	Output Capacitance	V _{OUT} = 0	8	10	pF
C _{IN2}	Control Pin Capacitance	V _{IN} = 0	8.5	10	pF

Note: Test conditions T_A = 25°C, f = 1.0 MHz

■ PLCC PIN CAPACITANCE

Parameter Symbol	Parameter Description	Test Setup	Typ.	Max.	Unit
C _{IN}	Input Capacitance	V _{IN} = 0	7	8	pF
C _{OUT}	Output Capacitance	V _{OUT} = 0	8	10	pF
C _{IN2}	Control Pin Capacitance	V _{IN} = 0	8.5	10	pF

Note: Test conditions T_A = 25°C, f = 1.0 MHz

■ PACKAGE DIMENSIONS

32-pin plastic QFJ(PLCC)
(LCC-32P-M02)

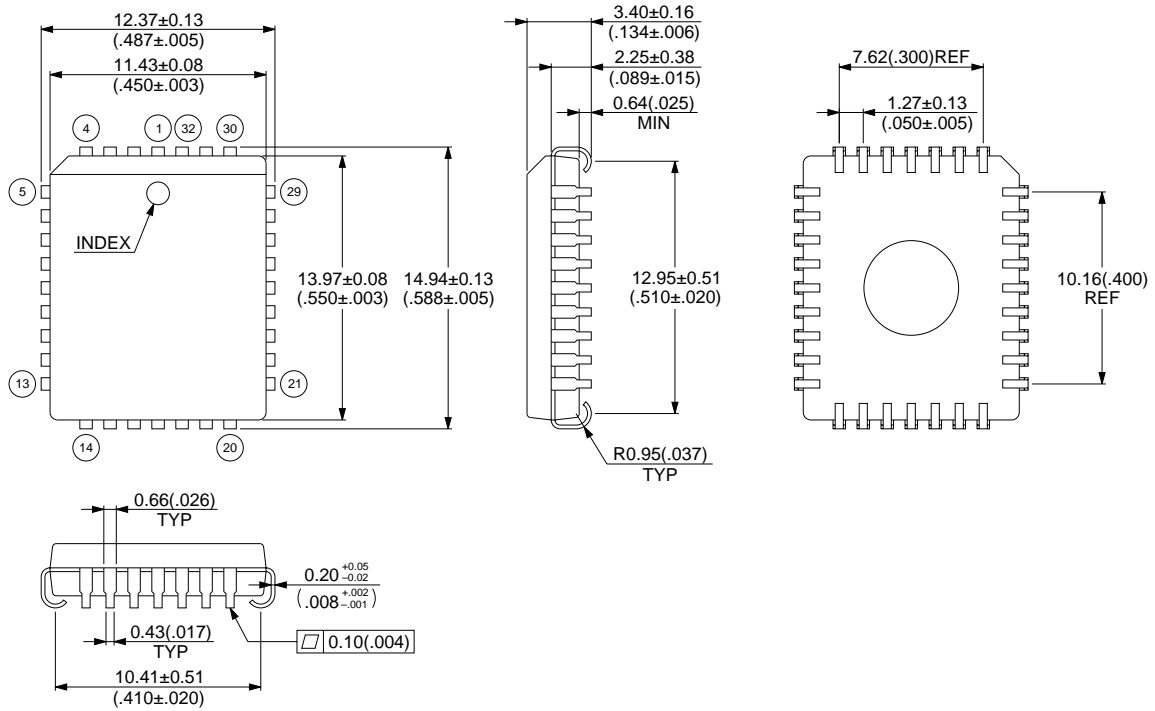

© 1994 FUJITSU LIMITED C32021S-2C-4

Dimensions in mm(inches)

(Continued)

MBM29F040C-55/-70/-90

32-pin plastic TSOP(I)
(FPT-32P-M24)

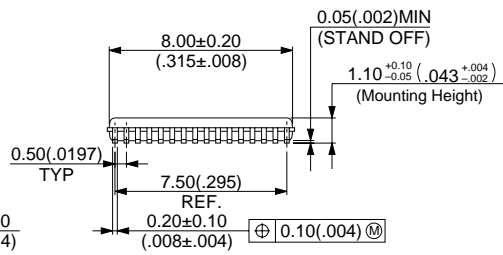
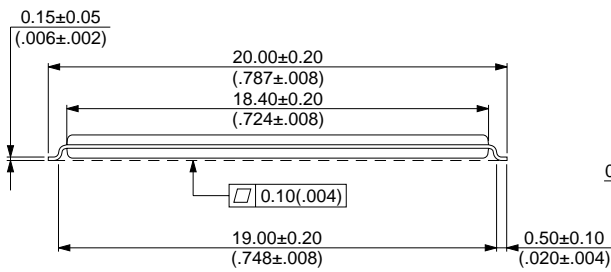
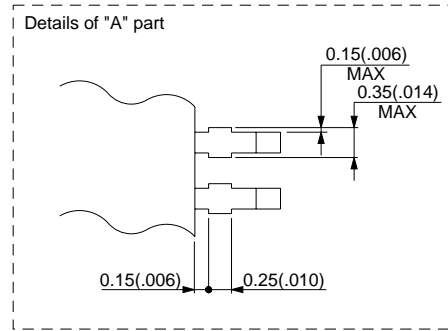
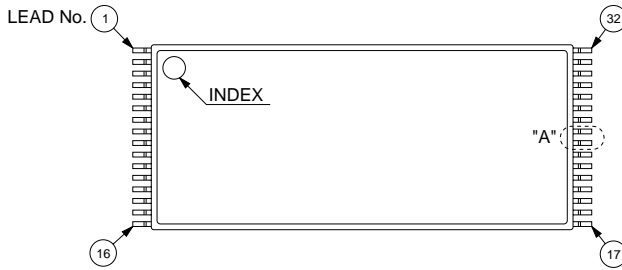

© 1994 FUJITSU LIMITED F32035S-2C-1

Dimensions in mm(inches)

(Continued)

(Continued)

32-pin plastic TSOP(I)
(FPT-32P-M25)

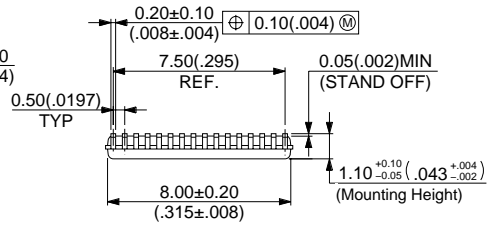
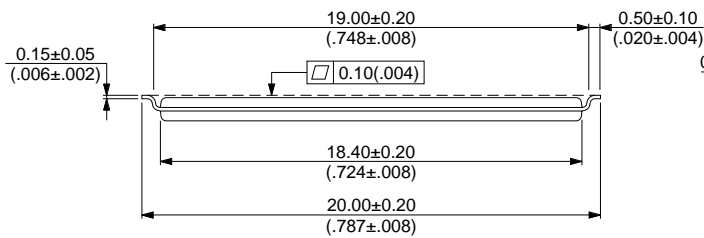
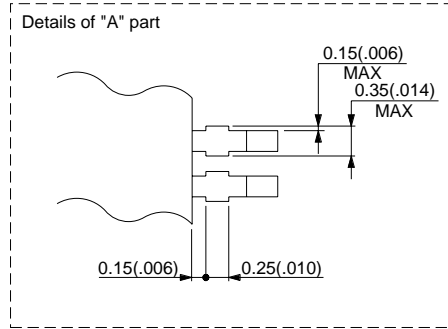
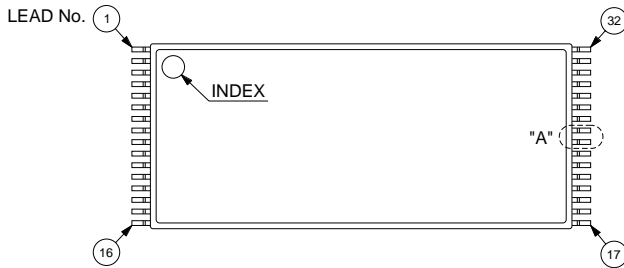

© 1997 FUJITSU LIMITED F32036S-2C-2

Dimensions in mm(inches)

FUJITSU LIMITED

For further information please contact:

Japan

FUJITSU LIMITED
Corporate Global Business Support Division
Electronic Devices
KAWASAKI PLANT, 4-1-1, Kamikodanaka
Nakahara-ku, Kawasaki-shi
Kanagawa 211-8588, Japan
Tel: 81(44) 754-3763
Fax: 81(44) 754-3329

<http://www.fujitsu.co.jp/>

North and South America

FUJITSU MICROELECTRONICS, INC.
Semiconductor Division
3545 North First Street
San Jose, CA 95134-1804, USA
Tel: (408) 922-9000
Fax: (408) 922-9179

Customer Response Center
Mon. - Fri.: 7 am - 5 pm (PST)
Tel: (800) 866-8608
Fax: (408) 922-9179

<http://www.fujitsumicro.com/>

Europe

FUJITSU MIKROELEKTRONIK GmbH
Am Siebenstein 6-10
D-63303 Dreieich-Buchsschlag
Germany
Tel: (06103) 690-0
Fax: (06103) 690-122

<http://www.fujitsu-edc.com/>

Asia Pacific

FUJITSU MICROELECTRONICS ASIA PTE LTD
#05-08, 151 Lorong Chuan
New Tech Park
Singapore 556741
Tel: (65) 281-0770
Fax: (65) 281-0220

<http://www.fmap.com.sg/>

F9903

© FUJITSU LIMITED Printed in Japan

All Rights Reserved.

The contents of this document are subject to change without notice. Customers are advised to consult with FUJITSU sales representatives before ordering.

The information and circuit diagrams in this document are presented as examples of semiconductor device applications, and are not intended to be incorporated in devices for actual use. Also, FUJITSU is unable to assume responsibility for infringement of any patent rights or other rights of third parties arising from the use of this information or circuit diagrams.

FUJITSU semiconductor devices are intended for use in standard applications (computers, office automation and other office equipment, industrial, communications, and measurement equipment, personal or household devices, etc.).

CAUTION:

Customers considering the use of our products in special applications where failure or abnormal operation may directly affect human lives or cause physical injury or property damage, or where extremely high levels of reliability are demanded (such as aerospace systems, atomic energy controls, sea floor repeaters, vehicle operating controls, medical devices for life support, etc.) are requested to consult with FUJITSU sales representatives before such use. The company will not be responsible for damages arising from such use without prior approval.

Any semiconductor devices have an inherent chance of failure. You must protect against injury, damage or loss from such failures by incorporating safety design measures into your facility and equipment such as redundancy, fire protection, and prevention of over-current levels and other abnormal operating conditions.

If any products described in this document represent goods or technologies subject to certain restrictions on export under the Foreign Exchange and Foreign Trade Law of Japan, the prior authorization by Japanese government will be required for export of those products from Japan.